

# ITS Communications Document

---

Prepared by:

Lockheed Martin Federal Systems  
Odetics Intelligent Transportation Systems Division

Prepared for:

Federal Highway Administration  
US Department of Transportation  
Washington, D. C. 20590

January 1997

# TABLE OF CONTENTS

<b>National ITS Communication – Executive Summary .....</b>	<b>ES-1</b>
<b>1. Introduction.....</b>	<b>1-1</b>
1.1 Purpose of Document.....	1-1
1.2 Structure of Document .....	1-2
<b>2. Introduction to the ITS Communication Architecture .....</b>	<b>2-1</b>
2.1 Role of the Communication Architecture.....	2-1
2.2 The Telecommunication Infrastructure and the ITS Communication Architecture Development Philosophy .....	2-2
2.3 Development of a Communications Architecture .....	2-5
2.4 Elements of the Communications Layer of the ITS Architecture.....	2-5
2.5 Relationship of the Communication Architecture Definition to the Data Loading Analysis and Simulations .....	2-7
<b>3. Communication Architecture Definition.....</b>	<b>3-1</b>
3.1 Communication Architecture .....	3-4
3.1.1 Communication Services .....	3-5
3.1.2 Logical Communication Functions.....	3-6
3.1.3 Functional Entities .....	3-7
3.1.4 Communication Network Reference Model.....	3-7
3.2 Communication Layer Linkage .....	3-9
3.2.1 Mapping Communication Services to Data Flows.....	3-9
3.2.2 Architecture Interconnect Diagrams .....	3-9
3.2.2.1 AID Template .....	3-10
3.2.2.2 Level 1 AIDs.....	3-11
3.2.2.3 Level 0 AID .....	3-12
3.2.3 Architecture Renditions .....	3-16
3.2.3.1 Level 1 Rendition .....	3-16
3.2.3.2 Level 0 Rendition .....	3-17
3.2.4 Architecture Interconnect Specifications .....	3-18
<b>4. Scenarios and Time Frames .....</b>	<b>4-1</b>
4.1 Evaluatory Design.....	4-1
4.2 Baseline Information for the Scenario Regions.....	4-1
4.3 Number of Potential Users by User Service Group.....	4-2
4.4 Penetrations.....	4-3
4.5 Assignment of Users to Communications Interfaces.....	4-5
4.6 Usage Profiles for the User Service Groups.....	4-13
4.7 4.7 Scenario Infrastructure Model .....	4-15
<b>5. Message Definition.....</b>	<b>5-1</b>
5.1 Message Definition Methodology .....	5-2
5.2 Message Structure .....	5-2
5.3 Message Set .....	5-4
<b>6. Data Loading Methodology and Results.....</b>	<b>6-1</b>
6.1 Data Loading Models.....	6-3
6.2 Wireless Data Loads .....	6-3
6.2.1 Two-Way Wireless Data Loads .....	6-3
6.2.1.1 Histogram of Message Size Distribution .....	6-30
6.2.2 Broadcast Data Loads .....	6-33
6.2.3 Short Range DSRC Data Loads .....	6-34

6.3 Wireline Data Loads .....	6-34
6.4 Analysis of the Data Loading Results .....	6-88
6.4.1 u1t Interface .....	6-88
6.4.2 u1b Interface .....	6-88
6.4.3 u2 Interface .....	6-89
6.4.4 u3 Interface .....	6-89
6.4.5 Wireline Interface .....	6-89
<b>7. Assessment of Communication Systems and Technologies.....</b>	<b>7-1</b>
7.1 Introduction.....	7-1
7.1.1 Objectives of the Technology Assessment.....	7-2
7.1.2 Underlying Assumptions .....	7-2
7.1.3 Section Structure.....	7-2
7.2 Communication Systems Analysis and Assessment Approach .....	7-5
7.2.1 Wireless Communication Systems Analysis .....	7-5
7.2.1.1 Wide-Area Communication Systems .....	7-5
7.2.1.2 Short-Range Communications .....	7-5
7.2.2 Wireline Communication Analysis .....	7-6
7.2.3 End-to-End Communication Analysis .....	7-6
7.3 Non-ITS Applications and Their Impact.....	7-7
7.3.1 Non-ITS Wireless Data Market Projections for 2002 .....	7-8
7.3.2 Characterization of Non-ITS Applications Traffic.....	7-10
7.3.2.1 E-Mail Traffic Characterization (12.7 Million Users) .....	7-10
7.3.2.2 Internet Access Traffic Characterization (12.7 Million Users).....	7-13
7.3.2.3 Other Non-ITS Applications.....	7-18
7.4 Protocol and Inter-networking Issues.....	7-19
7.5 Technology Assessment.....	7-20
7.5.1 Wireless Communications .....	7-20
7.5.1.1 Wide-Area versus Short-Range .....	7-22
7.5.1.2 Short Range ITS Communications .....	7-97
7.5.2 Wireline Communications .....	7-101
7.5.2.1 Candidate Wireline Technologies.....	7-102
7.5.2.2 Candidate Wireline Topologies .....	7-103
7.5.2.3 Public Network Usage .....	7-104
7.5.2.4 Localized Use of Internet.....	7-105
7.6 Technology Survey and Assessment Summary.....	7-114
<b>8. Communication Systems Performance – A Case Study.....</b>	<b>8-1</b>
8.1 Wireless Systems Performance .....	8-2
8.1.1 Scope of Performance Analysis .....	8-2
8.1.1.1 Urbansville 2002 and 2012.....	8-2
8.1.1.2 Thruville 2002 .....	8-13
8.1.1.3 Mountainville .....	8-14
8.1.2 Simulation Strategy.....	8-14
8.1.3 CDPD Protocol Overhead.....	8-17
8.1.4 Non-ITS Applications CDPD Data Loads .....	8-21
8.1.5 CDPD Data Loads .....	8-22
8.1.5.1 Urbansville .....	8-22
8.1.5.2 Thruville 2002 .....	8-44
8.2 CDPD Simulation Results.....	8-55
8.2.1 Urbansville 2002 and 2012.....	8-55
8.2.1.1 Capacity Comparison of One Reserved CDPD Channel versus One Reserved Plus One Dynamically Assigned CDPD Channels.....	8-57
8.2.1.2 Urbansville 2012 -- One Reserved CDPD Channel.....	8-58
8.2.1.3 Urbansville 2002 -- One Reserved CDPD Channel.....	8-61
8.2.1.4 Urbansville 2002 -- Dynamic Assignment of CDPD Channels (No Reserved Channel).....	8-72
8.2.2 Thruville 2002 .....	8-77
8.2.3 Mountainville.....	8-81
8.3 Wireline System Performance.....	8-83

8.3.1 Traffic Over the Wireline Portion of the CDPD Network..... 8-83  
8.4 End-to-End System Performance..... 8-86  
8.4.1 Scope of Performance Analysis..... 8-86  
8.4.2 Results..... 8-87

**9. ITS Architecture Communication – Conclusions..... 9-1**

**Communications Document HRI Addendum - January 1997**

# APPENDICES

<b>Appendix A</b>	<b>Communication Architecture Development and Definitions</b>	<b>A-1</b>
A.1	Communication Services Descriptions	A-1
A.1.1	Interactive Services	A-4
A.1.2	Distribution Services	A-5
A.1.3	Location Services	A-5
A.1.3.1	Location Determination Techniques	A-6
A.1.3.2	Types of Location Services	A-6
A.1.3.3	Service Deployment Issues	A-7
A.2	Logical Communication Function Definitions	A-7
A.3	Network Entity Definitions	A-8
A.4	Network Reference Model	A-12
A.5	Communication Architecture Linkage	A-14
A.5.1	Mapping Communication Services to Data Flows	A-14
<b>Appendix B</b>	<b>Architecture Interconnect Diagrams - Level 1</b>	<b>B-1</b>
<b>Appendix C</b>	<b>Communication Architecture Renditions and Applicable Technologies</b>	<b>C-1</b>
C.1	Format/Purpose	C-2
C.1.1	Level 0 Rendition	C-2
C.1.2	Level 1 Rendition	C-3
C.2	Applicable Technologies Mapped to the Renditions	C-27
<b>Appendix D</b>	<b>Technology Assessment Sources</b>	<b>D-1</b>
D.1	Wireless	D-1
D.1.1	MAN's	D-1
D.1.2	Land Mobile Systems	D-2
D.1.3	Satellite Mobile Systems	D-4
D.1.4	Meteor Burst Systems	D-5
D.1.5	Broadcast Systems	D-5
D.1.5.1	FM Subcarrier	D-5
D.1.5.2	DAB	D-5
D.1.6	Short-Range Communications	D-5
D.1.6.1	DSRC Communications	D-5
D.1.6.2	Vehicle-to-Vehicle Communications	D-6
D.2	Wireline Communications	D-6
<b>Appendix E</b>	<b>Potential Users According to User Service Group</b>	<b>E-1</b>
E.1	Private Vehicle Service Group Users – Urbansville, 1997	E-2
E.2	CVO - Long-Haul Service Group Users	E-3
E.3	CVO - Local Service Group Users	E-3
E.4	Traveler Information Service Group Users	E-4
E.5	Public Transportation Management Service Users	E-4
E.6	Emergency Response Vehicles Management Services	E-4
E.7	Probes	E-4
<b>Appendix F</b>	<b>Message Definitions And Data Loading Models</b>	<b>F-1</b>
<b>Appendix G</b>	<b>Use of Beacons For Wide Area Delivery/Collection Of ITS Information</b>	<b>G-1</b>
G.1	Introduction	G-1
G.2	Candidate Beacon Deployment	G-2
G.3	Message Compatibility with DSRC	G-3
G.4	Impact of ITS Data on Beacon Capacity	G-3
G.5	Impact of DSRC Traffic on Wireline Network	G-3

G.6 Some Problems with Beacon Systems.....	G-6
G.7 Summary .....	G-9
<b>Appendix H Wireless and Wireline Protocols .....</b>	<b>H-1</b>
H.1 Wireless Protocols .....	H-1
H.1.1 CDPD.....	H-1
H.1.2 CDPD Protocols as Implemented in MOSS.....	H-1
H.1.3 GPRS .....	H-5
H.2 Wireline Protocols .....	H-5
H.2.1 Ethernet.....	H-5
H.2.2 FDDI.....	H-6
H.2.3 ATM .....	H-6
<b>Appendix I Simulation Tools.....</b>	<b>I-1</b>
I.1 Introduction .....	I-1
I.2 Wireless Communications (Cellular/PCS).....	I-3
I.2.1 Graphical Radio Network Engineering Tool (GRANET).....	I-4
I.2.2 MOBILE Systems Simulator (MOSS) .....	I-5
I.2.3 Integrated GRANET+MOSS.....	I-7
I.3 OPTimized Network Engineering Tools (OPNET) .....	I-8
I.3.1 Wireline Communications .....	I-8
I.3.2 Wireless + Wireline Simulation Integration .....	I-9
I.4 Validation of the Modeling Tools.....	I-9
<b>Appendix J CDPD Field Trial Results .....</b>	<b>J-1</b>
J.1 Introduction .....	J-1
J.2 Trial Objectives .....	J-2
J.3 Trial Participants .....	J-2
J.4 FleetMaster System and Trial Configuration.....	J-3
J.5 Sample Field Results .....	J-4
J.5.1 Signal Strength and Waiting Time Measurements .....	J-4
J.5.2 TCP versus UDP .....	J-6
J.5.3 CDPD System Loading Limits .....	J-7
J.5.4 Application Inter-Arrival Times with UDP.....	J-7
J.6 Operation in Customer's Vehicles and Billing System Validation Tests.....	J-10
J.7 Summary of Conclusions.....	J-11

## FIGURES

Figure 2.2-1 Overview of the Telecommunications Arena .....	2-2
Figure 2.4-1 Communication Architecture Development Process .....	2-6
Figure 3.0-1 Communications Architecture Development Process .....	3-3
Figure 3.1-1 Generic Hierarchical Communication Model .....	3-5
Figure 3.1-2 Communication Services Hierarchy .....	3-6
Figure 3.1-3 Network Reference Model for the Communications Layer .....	3-8
Figure 3.1-4 Implementation Flexibility of ITS Architecture Data Flows .....	3-8
Figure 3.2-1. Template for the Architecture Interconnect Diagram (AID) .....	3-11
Figure 3.2-2 Example of AID Level-1 .....	3-11
Figure 3.2-3 Level 0 Architecture Interconnect Diagram for the National ITS Architecture.....	3-13
Figure 3.2-4 Level 0 Architecture Interconnect Diagram for the National ITS Architecture.....	3-14
Figure 3.2-5 Level 0 Architecture Interconnect Diagram for the National ITS Architecture;.....	3-15
Figure 3.2-6 Rendition 1 — Wide-Area Wireless (u1) Link Through Switched Networks .....	3-16
Figure 3.2-7 Rendition 1 for Wide-Area One-Way Wireless (u1b) Links .....	3-17
Figure 3.2-8 Level 0 Rendition .....	3-18
Figure 3.2-9 AIS Example Using CDPD for Wide Area Wireless (u1) .....	3-19
Figure 5.1-1 Level 0 Architecture Interconnect Diagram for the National ITS Architecture.....	5-1
Figure 5.2-1 Examples of Message Structures .....	5-2
Figure 5.2-2 Details of the Message_ID Field which Allows Standard, Optional, and Repeated Fields to be Appended to the Message .....	5-3
Figure 5.2-3 Example of an Optional-Field Message.....	5-3
Figure 5.2-4 Example of a Message with Three Sets of Repeated Fields .....	5-4
Figure 6.2-26 Distribution of Messages per Population, Urban Area, 2002, Peak Period.....	6-32
Figure 7.3-1 2002 Wireless Data Market Projections (from External and GTE Market Studies).....	7-10
Figure 7.3-2 Time-of-Day E-mail Pattern -- Incoming E-mail.....	7-11
Figure 7.3-3 Time-of-Day E-mail Pattern -- Outgoing E-mail.....	7-11
Figure 7.3-4 Histogram of Message Size up to 100 kbytes (Not to Scale).....	7-12
Figure 7.3-5 Histogram of Wireless E-mail Message Sizes (up to 5 kbytes).....	7-13
Figure 7.3-6 Daily Statistics for the Boston University WWW Server.....	7-14
Figure 7.3-7 Daily Statistics for the MIT WWW Server .....	7-15
Figure 7.3-8 Weekly Statistics from the Boston University WWW Server .....	7-16
Figure 7.3-9 Weekly Statistics from the MIT WWW Server.....	7-17
Figure 7.5-1 Metricom's Present and Planned Coverage in the San Francisco Bay Area.....	7-24
Figure 7.5-2 Example of a City-wide Deployment of Metricom's Ricochet System .....	7-25
Figure 7.5-3 CDPD Deployment as of the Fourth Quarter of 1995 .....	7-29
Figure 7.5-4 CDPD Network Architecture.....	7-29
(From <i>Wireless Information Networks</i> , K. Pahlavan, A. Levesque, John Wiley & Sons, Inc., 1995. Note: the A interface is referred to in this document as the u1t interface). .....	7-29
Figure 7.5-5 CDPD Protocol Stack (CDPD System Specification, Release 1.0).....	7-31
Figure 7.5-6 CDPD Protocol Stack (CDPD System Specification, Release 1.1).....	7-32
Figure 7.5-7 Average Delay/Call Duration Ratio: CDPD versus Circuit-Switched CDMA .....	7-37
Figure 7.5-8 Omnipoint's System Architecture and Public-Private Operation .....	7-39
Figure 7.5-9 GSM Frame and Slot Structure .....	7-41
Figure 7.5-10 ARDIS Coverage in the Mid-Atlantic and Southern California Regions .....	7-44
Figure 7.5-11 ARDIS Network Architecture .....	7-45
Figure 7.5-12 MOBITEK Network Architecture .....	7-47
Figure 7.5-13 Satellite Orbits.....	7-54

Figure 7.5-14 Location of, and Coverage Provided by, the Two Already Deployed ORBCOMM Satellites at Two Instants in Time .....	7-56
Figure 7.5-15 Iridium System Footprint at a Given Point in Time.....	7-59
Figure 7.5-16 Path Described by a Teledesic Satellite.....	7-60
Figure 7.5-17 ICO's Satellite Orbits .....	7-63
Figure 7.5-18 SKYCELL Coverage.....	7-64
Figure 7.5-19 MSAT North American Coverage.....	7-65
Figure 7.5-20 VSAT Network Configuration .....	7-71
Figure 7.5-21 GPS Constellation .....	7-72
Figure 7.5-22 GLONASS Constellation .....	7-73
Figure 7.5-23 Motion of Ground Illumination Region due to Trail Formation and Decay .....	7-74
Figure 7.5-24 Effect of Trail Location on Size of Footprint .....	7-74
Figure 7.5-25 FM Spectrum Allocation in North America and Europe .....	7-78
Figure 7.5-26 FM Baseband Spectrum (Not to scale).....	7-79
Figure 7.5-27 Single Group Standard RDS Message.....	7-80
Figure 7.5-28 SCA FM Spectrum .....	7-82
Figure 7.5-29 HSDS Coverage in the Southern California Area for Wrist-Watch Receiver (-29 dBi antenna).....	7-83
Figure 7.5-30 HSDS Coverage in the Portland, OR, and Seattle, WA, Areas for Wrist-Watch Receiver (-29 dBi antenna).....	7-84
Figure 7.5-31 FM Baseband Spectrum usage for Seiko's HSDS System .....	7-85
Figure 7.5-32 FM Baseband Spectrum Usage for MITRE's STIC System.....	7-87
Figure 7.5-33 FM Baseband Spectrum Usage for NHK's DARC System .....	7-88
Figure 7.5-34 Full Deployment of a Beacon System .....	7-94
Figure 7.5-35 Dead Zone Crossing Times .....	7-95
Figure 7.5-36 Beacon Coverage Crossing Time .....	7-96
Figure 7.5-37 PDF's of the Round-Trip Delay .....	7-106
Figure 7.5-37 PDF's of the Round-Trip Delay (Cont.).....	7-107
Figure 7.5-38 Average Round-Trip Delay (Period March 5-7, 1996) .....	7-108
Figure 7.5-38 Average Round-Trip Delay (Period March 5-7, 1996) (Cont.) .....	7-109
Figure 7.5-39 Example of the Range of Round-Trip Delays (Boston, March 5-7, 1996) .....	7-110
Figure 7.5-39 Example of the Range of Round-Trip Delays (Boston, March 5-7, 1996) (Cont'd) .....	7-111
Figure 7.5-40 Minimum-Average-Maximum Packet Loss (Boston, March 5-7, 1996) .....	7-112
Figure 7.5-40 Minimum-Average-Maximum Packet Loss (Boston, March 5-7, 1996) (Cont'd)....	7-113
Figure 8.1-1 Base Station Locations in the Detroit Area .....	8-11
Figure 8.1-2 Best Server Map of the Detroit Area (Obtained Using GRANET) .....	8-12
Figure 8.1-3 Communication System Simulation/Evaluation Methodology .....	8-15
Figure 8.1-4 Quantitative Technical MOE's.....	8-17
Figure 8.1-5 CDPD Protocol Stack (Cellular Digital Packet Data System Specification, Release 1.0).....	8-18
Figure 8.1-6 Framing and Block Structure Showing the Color Code.....	8-20
Figure 8.1-7 Histogram of Wireless E-mail Message Sizes (up to 5 kbytes) .....	8-21
Figure 8.1-8 Average File Transfer Size for the MIT WWW Server (All day Average: 8490 bytes) .....	8-22
Figure 8.1-9 Location of the Incident showing the Sectors Involved, as well as the Sectors and Roadway Segments Affected by the Incident.....	8-43
Figure 8.1-10 Extension of the Queues induced by the Incident immediately before its Dissipation, showing the Affected Sectors.....	8-54
Figure 8.2-1 Detroit (Urbansville) Coverage .....	8-56
Figure 8.2-2 Capacity of a Reserved CDPD Channel .....	8-57
Figure 8.2-3 Capacity of One Reserved plus One Dynamically Assigned CDPD Channels .....	8-58
Figure 8.2-4 Delay/Throughput Pairs for the Actual Cellular Deployment in Detroit .....	8-59
Figure 8.2-5 Delay Map for an Actual Cellular Deployment in Detroit.....	8-60
Figure 8.2-6 Reverse Link CDPD Delay Histograms on a Logarithmic Scale.....	8-61



Figure 8.2-6 ( Cont.) Reverse Link CDPD Delay Histograms on a Logarithmic Scale .....	8-62
Figure 8.2-6 (Con't.) Reverse Link CDPD Delay Histograms on a Logarithmic Scale .....	8-63
Figure 8.2-7 Average Delay and Standard Deviation as a function of Packet Length .....	8-64
Figure 8.2-8 Delay-Throughput Pairs for all the Sectors in Detroit 2002 .....	8-65
Figure 8.2-9 ITS only CDPD Reverse Link Delay for Detroit (Urbansville).....	8-66
Figure 8.2-10 Average Delay and Standard Deviation as a Function of Packet Length.....	8-67
Figure 8.2-11 Delay-Throughput Pairs for Detroit 2002 for ITS plus Non-ITS .....	8-68
Figure 8.2-12 ITS plus Non-ITS CDPD Reverse Link Delay for Detroit (Urbansville).....	8-69
Figure 8.2-13 Delay-Throughput Pairs for Detroit 2002 for ITS plus Non-ITS in case of Incident .....	8-70
Figure 8.2-14 ITS plus Non-ITS with Incident CDPD Reverse Link Delay for Detroit (Urbansville).....	8-71
Figure 8.2-15 Delay PDF's as a Function of the Packet Length in RS-blocks, for 3-Dynamically Assigned CDPD Channels (No Reserved) for ITS+Non-ITS Data Loads .....	8-72
Figure 8.2-16 Delay PDF's as a Function of the Packet Length in RS-blocks, for 3-Dynamically Assigned CDPD Channels (No Reserved) for ITS+Non-ITS Data Loads .....	8-73
Figure 8.2-17 Delay PDF's as a Function of the Packet Length in RS-blocks, for 3-Dynamically Assigned CDPD Channels (No Reserved) for ITS+Non-ITS Data Loads .....	8-74
Figure 8.2-18 Average Delay and Standard Deviation for 3-Dynamically Assigned CDPD Channels .....	8-75
Figure 8.2-19 Delay-Throughput for 3-Dynamically Assigned CDPD Channels (No Reserved) for ITS+Non-ITS Data Loads.....	8-76
Figure 8.2-20 Delay-Throughput Pairs Observed in Three Different Simulation Runs for 3- Dynamically Assigned CDPD Channels (No Reserved) for ITS+Non-ITS Data Loads.....	8-77
Figure 8.2-21 CDPD Reverse Link Delay for ITS plus Non-ITS Data Loads and 3-Dynamically Assigned CDPD Channels .....	8-78
Figure 8.2-22 Philadelphia-Trenton Corridor (Thruville) Coverage.....	8-81
Figure 8.2-23 Delay-Throughput Pairs for ITS Only Data Loads for Thruville 2002 .....	8-81
Figure 8.2-24 Delay-Throughput Pairs for ITS plus Non-ITS Data Loads for Thruville 2002.....	8-82
Figure 8.2-25 Lincoln County, Montana (Mountainville) Coverage.....	8-83
Figure 8.3-1 Network to be Simulated to Assess End-to-End Performance.....	8-84
Figure 8.3-2 M-ES/F-ES Origin-Destination Pairs .....	8-85
Figure 8.4-1 CDPD Protocol Stack for End-to-End Performance Evaluation (Shows the Portion to be Replaced by MOSS' CDPD Traffic Characterization in Terms of Delay) .....	8-86
Figure 8.4-2 Portion of the CDPD Network that has been Simulated (Corresponding to One Sector of the Cellular Deployment).....	8-87
Figure 8.4-3 RAS -> RS (Reverse Link) Assuming 100 s with No Packet Loss followed by 40 s with 10% Packet Loss, and then 60 s with No Packet Loss.....	8-88
Figure 8.4-4 FMS -> CVO Local (Forward Link) .....	8-91
Figure 8.4-5 CVO Local -> FMS (Reverse Link) .....	8-91
Figure 8.4-6 ISP -> Private Vehicle (Forward Link) .....	8-92
Figure 8.4-7 Private Vehicle -> ISP (Reverse Link).....	8-92
 Figure A.1-1 Communication Services Hierarchy .....	 A-1
 Figure B-1 First Level EM - EVS AID .....	 B-2
Figure B-2 First Level PIAS-EM AID .....	B-2
Figure B-3 First Level PIAS-TRMS AID .....	B-3
Figure B-4 First Level RTS-EM AID .....	B-3
Figure B-5 First Level PMS-ISP AID.....	B-4
Figure B-6 First Level PMS-TMS AID .....	B-4
Figure B-7 First Level PMS-VS AID .....	B-5
Figure B-8 First Level ISP-EM AID.....	B-5
Figure B-9 First Level ISP-TRMS AID.....	B-6
Figure B-10 First Level ISP-TMS AID.....	B-6

Figure B-11 First Level ISP-FMS AID.....	B-7
Figure B-12 First Level ISP-VS AID.....	B-7
Figure B-13 First Level TMS-TRMS AID .....	B-8
Figure B-14 First Level TMS-EM AID .....	B-8
Figure B-15 First Level RS-VS AID.....	B-9
Figure B-16 First Level TMS-RS AID .....	B-10
Figure B-17 First Level TMS-EMMS AID.....	B-10
Figure C.1-2 Communication Architecture – Transportation Layer Interaction .....	C-4
Figure C.1-3a Rendition 1 — $u_{1a}$ , Two-Way Wide-Area Wireless Link .....	C-5
Figure C.1-3b Rendition 1 — $u_{1b}$ , One-way Wide-Area Wireless Link.....	C-6
Figure C.1-4 Rendition 2 – $u_2$ Close Proximity Mobile to Stationary User Link.....	C-10
Figure C.1-5 Rendition 3 – $u_3$ , Close Proximity Vehicle-to-Vehicle Connection .....	C-14
Figure C.1-6 Rendition 4 – $w$ , The Wireline Connection.....	C-15
Figure C.2-1 Technology Mapping onto Level 0 Rendition .....	C-27
Figure C.2-2 Candidate Technologies for Rendition Level 1 – Two-Way Wide Area Wireless Link.....	C-28
Figure G.2-1 Full Deployment of a Beacon System.....	G-2
Figure G.6-1 Transmission Delay as a Function of Vehicle Velocity .....	G-6
Figure G.6-2 Time a Vehicle will Remain in the Coverage Area of a Beacon.....	G-8
Figure G.6-3 Location Uncertainty as a Function of Elapsed Time.....	G-8
Figure H.1-1 Packet Segmentation in CDPD.....	H-3
Figure J.4-1 CVO-CDPD Field Trial Configuration.....	J-3
Figure J.5-1 Received CDPD Signal Strength Inside a Vehicle During a Run in Jan. 1995.....	J-5
Figure J.5-2 PDF of the Polling Waiting Time .....	J-5
Figure J.5-3 CDF of the Polling Waiting Time.....	J-6
Figure J.5-4 Histogram of Inter-Arrival Times Between Position Reports in FleetMaster Log (reporting at roughly 15 s intervals without ACK).....	J-8
Figure J.5-5 Histogram of Inter-Arrival Times Between Position Reports in FleetMaster Log (reporting at roughly 15 s intervals without ACK).....	J-8
Figure J.5-6 Histogram of Inter-Arrival Times Between Position Reports in FleetMaster Log .....	J-9

## TABLES

Table 2.2-1 Communications Technology Projections for the Next 15 Years.....	2-4
Table 3.2-1 Examples of Candidate Technologies for Wireless Data Flows .....	3-20
Table 4.2-1 Supplied Population and Household Vehicle Data.....	4-1
Table 4.3-1 Number of Potential Vehicles or Users for Each of the Seven User Service Groups and Each of the Nine Scenarios. ....	4-3
Table 4.4-1 Penetration Factor by Market Package and Time Frame .....	4-4
Table 4.5-1 Communications Interfaces Assigned to Each of the Messages .....	4-6
Table 5.3-1 Market Package Deployment by Time Frame (All are Deployed in Urbansville and Thruville in 2012).....	5-5
Table 6.2-1 Summary of Data Loading Results .....	6-29
Table 6.2-2 Candidate Messages for One Way Wireless Communication.....	6-34
Table 6.3-1 Independent Parameters Used in the Wireline Data Loading .....	6-35
Table 6.3-2 Dependent Parameters Used in the Wireline Data Loading Analysis.....	6-40
Table 6.3-3 Wireline Data Loading Analysis, 2012, Urbansville .....	6-47
Table 7.1-1 Communications Technology Projections to the Year 2012.....	7-4
Table 7.3-1 Wireless Data Market Projections (from External and GTE Market Studies).....	7-9
Table 7.5-1 Technical Specifications of the Wireless Data Technologies for Fixed Subscribers .....	7-27
Table 7.5-2 Typical and Minimum Duration of IS-95-A Call Steps .....	7-35
Table 7.5-3 Summary of ITS Call Duration for IS-95-A Circuit-Switched Service (Slotted Mode) .....	7-35
Table 7.5-4 SkyTel 2-Way Paging Service Specifications.....	7-50
Table 7.5-5 Motorola’s Tango™ Two-Way Messaging Unit Specifications.....	7-50
Table 7.5-6 Little LEO’s.....	7-57
Table 7.5-7 Comparative Analysis of Big LEO’s .....	7-61
Table 7.5-8 Comparative Analysis of MEO and HEO Satellite Systems.....	7-66
Table 7.5-9 Comparative Analysis of GEO Satellite Systems .....	7-67
Table 7.5-10 Comparison of HSDS and RDS-TMC.....	7-86
Table 7.5-10 ITS Required Information Rates and Broadcast Systems Capacity .....	7-89
Table 7.5-11 Summary of the Broadcast System Specifications.....	7-90
Table 7.5-12 Beacon Systems Specifications.....	7-98
Table 7.5-13 Widely Available Public Network Technologies.....	7-104
Table 7.6-1 Definition of the Entries in the Summary Tables.....	7-114
Table 7.6-2 Summary Comparison of Wireless MAN and Cell-based Land Mobile Systems.....	7-117
Table 7.6-3 Summary Comparison of Proposed Satellite Systems .....	7-118
Table 8.1-1 Summary of DCTC FCC Filings (Nov. 1993).....	8-4
Table 8.1-2 Characterization of the DCTC Site #25.....	8-9
Table 8.1-3 Manufacturer-Provided Pattern for DB874H83 Antenna .....	8-10
Table 8.1-4 Market Penetration Figures Derived from Preliminary Market Studies.....	8-16
Table 8.1-5 CDPD Packet Length Distribution for Non-ITS Data .....	8-22
Table 8.1-6 Private Vehicles Data Load for the Year 2012—Projected Penetration.....	8-24
Table 8.1-7 Long-Haul Freight and Fleet Vehicles Data Load for the Year 2012.....	8-25
Table 8.1-8 Local Freight and Fleet Vehicles Data Load for the Year 2012 .....	8-26
Table 8.1-9 Emergency Vehicles Data Load for the Year 2012 .....	8-27
Table 8.1-10 Public Transportation Services Data Load for the Year 2012 .....	8-28
Table 8.1-11 Traveler Information Services Data Load for the Year 2012 .....	8-29
Table 8.1-12 Probe Vehicles Data Load for the Year 2012.....	8-30
Table 8.1-13 Overall IVHS Data Load Summary for the Year 2012.....	8-31

Table 8.1-14 Private Vehicles CDPD Traffic for the Year 2002 .....	8-33
Table 8.1-15 Long-Haul Freight and Fleet Vehicles CDPD Traffic for the Year 2002 .....	8-34
Table 8.1-16 Local Freight and Fleet Vehicles CDPD Traffic for the Year 2002 .....	8-35
Table 8.1-18 Transit Vehicles CDPD Traffic for the Year 2002 .....	8-36
Table 8.1-19 Personal Information Access CDPD Traffic for the Year 2002 .....	8-37
Table 8.1-20 Probe Vehicles CDPD Traffic for the Year 2002 .....	8-38
Table 8.1-21 Overall ITS CDPD Traffic Summary for the Year 2002 .....	8-40
Table 8.1-22 Non-ITS CDPD Traffic .....	8-41
Table 8.1-23 Overall ITS plus Non-ITS CDPD Traffic.....	8-41
Table 8.1-24 Private Vehicles CDPD Traffic for the Year 2002 .....	8-45
Table 8.1-25 Long-Haul Freight and Fleet Vehicles CDPD Traffic for the Year 2002 .....	8-46
Table 8.1-26 Local Freight and Fleet Vehicles CDPD Traffic for the Year 2002 .....	8-47
Table 8.1-28 Transit Vehicles CDPD Traffic for the Year 2002 .....	8-48
Table 8.1-29 Personal Information Access CDPD Traffic for the Year 2002 .....	8-49
Table 8.1-31 Overall ITS CDPD Traffic Summary for Thruville 2002 .....	8-52
Table 8.1-32 Non-ITS CDPD Traffic for Thruville 2002.....	8-53
Table 8.1-33 Overall ITS plus Non-ITS CDPD Traffic for Thruville 2002 .....	8-53
Table 8.3-1 ITS Origin-Destination Pairs Traffic (RS-blocks/s/Sector) .....	8-85
Table 8.4-1 Total Traffic Departing from/Arriving at the F-ES's.....	8-88
Table A.1-1 Interactive Services .....	A-4
Table A.1-2 Distribution Services.....	A-5
Table A.5-1 Data Flow – Communications Service Mapping.....	A-18
Table A.5-1 Data Flow – Communications Service Mapping (Cont'd).....	A-19
Table C.1-1a Wireless Wide Area Data Flows ( $u_{1a}$ ).....	C-7
Table C.1-1b Wireless Wide Area Data Flows ( $u_{1b}$ ).....	C-9
Table C.1-2 Short Range (Close-Proximity Mobile-Fixed) Wireless Data Flows ( $u_2$ ) .....	C-11
Table C.1-3 Wireline Connection Data Flows ( $w$ ).....	C-16
Table F-1 Data Loading Models for the Wide-Area Wireless Two-Way ( $u_{1t}$ ) Interface.....	F-2
Table G.5-1 ITS Wireless Messages for the $u_2$ Interface .....	G-5
Table J.3-1 Participating Organizations and their Responsibilities.....	J-2
Table J.6-1. Comparison of Application Log and Billing Records .....	J-10

# **NATIONAL ITS COMMUNICATION**

## **EXECUTIVE SUMMARY**

In the last decade, many communication technologies and systems have been introduced at an ever-accelerating pace, and some are gaining wide acceptance. The complex world of telecommunications is evolving and expanding rapidly. For many application areas, including transportation, myriad communication options are available to the system architect and designer. These solutions, of course, meet the requirements at hand with varying results and implications of performance, cost, and user acceptance.

The ITS world is also broad and varied, as amply demonstrated by the twenty-nine ITS user services, their distinct needs, and their complex interactions and synergies. The National ITS Architecture can be viewed as a framework that ties together the transportation and telecommunication worlds, to enable the creation, and effective delivery, of the broad spectrum of ITS services. Throughout the Architecture effort, the emphasis has been on flexibility. This allows the local implementors and service providers to select the specific technologies, within the framework of the architecture, that best meet their needs (expressed either in terms of market realities or jurisdictional constraints). The price paid in the architecture is some added complexity. It has been critical, therefore, to espouse an architectural concept that mitigates the complexity of interconnecting many transportation systems with multiple types of communication links. The basic concept wherein the Physical Architecture has a Transportation and a Communication Layer is specifically intended to simplify the process by separating these two fairly independent domains, yet, at the same time, having them tightly coupled to meet the ITS users service requirements.

This National ITS Communication Document contains, under the same cover, the information necessary to describe and characterize all aspects of communications within the National ITS Architecture. It presents a thorough, coherent definition of the “communication layer” of the Architecture. From a National ITS Program perspective, this encompasses two broad thrusts: 1) communication architecture definition (i.e., selection of communication service and media types to interconnect the appropriate transportation systems), and 2) several types of inter-related

communication analyses to ensure the feasibility and soundness of the architectural decisions made in the definition. The analyses performed comprise:

- An analysis of the data loading requirements derived from the ITS user service requirements, the Logical and Physical Architectures and their data flows, the ITS service deployment timeline, and the attributes of the candidate scenarios in the “evaluatory design”.
- A wide-ranging, balanced assessment of a broad spectrum of communication technologies that are applicable to the interconnections defined in the communication layer of the Physical Architecture. The evaluation is performed from a National ITS Architecture standpoint.
- An in-depth, quantitative analysis of the real-world performance of selected technologies that are good candidates for adoption as ITS service delivery media, and for which reliable, state-of-the-art simulation tools are available. The performance is determined under the demands of the ITS and other projected applications of the media.
- A number of supporting technical and economic telecommunications analyses that address some important architecture-related issues, such as the appropriate use of dedicated short range communication (DSRC) systems.

One of the fundamental guiding philosophies in developing the National Architecture has been to leverage the existing and emerging infrastructures, both transportation and communication. This is to maximize the feasibility of the architecture, and to mitigate the risk inherent in creating and offering intelligent transportation systems, services, and products, all of which are quite new and in need of acceptance.

The communication architecture definition adopts the same philosophy. It follows, and expands upon, a rigorous, well-accepted methodology used widely in the world of telecommunications. Several wireless systems which are tied to wireline networks have used this approach. It starts from the basic network functions and building blocks and proceeds to the definition of a network reference model, which identifies the physical communication equipment (e.g., base station), to perform the required communication functions, and the interfaces between them. These interfaces are the most salient element of the model from an ITS perspective; some of these interfaces need to be standardized to ensure interoperability.

Because of the variances in the ITS user service requirements (from a communication perspective), it is clear, even from a cursory examination, that the user services do not share a common information transfer capability. Specifically, ITS user services like electronic toll collection demand communication needs that can only be met by dedicated infrastructures for technical feasibility, notwithstanding institutional, reasons. The ITS network reference model that was developed incorporates this basic extension of the models developed for commercial telecommunication networks.

In general, the Communication Architecture for ITS has two components: one wireless and one wireline. All Transportation Layer entities requiring information transfer are supported by one, or both, of these components. In many cases, the communication layer appears to the ITS user (on the transportation layer) as “communication plumbing”, many details of which can, and should, remain transparent. Nevertheless, the basic telecommunication media types have critical architectural importance. The wireline portion of the network can be manifested in many different ways, most implementation dependent. The wireless portion is manifested in three basic, different ways:

- Wide-area wireless infrastructure, supporting wide-area information transfer (many data flows). For example, the direct use of existing and emerging mobile wireless systems. The

wireless interface to this infrastructure is referred to as u1. It denotes a wide area wireless airlink, with one of a set of base stations providing connections to mobile or untethered users. It is typified by the current cellular telephone and data networks or the larger cells of Specialized Mobile Radio for two way communication, as well as paging and broadcast systems. A further subdivision of this interface is possible and is used here in the document: u1t denotes two-way interconnectivity; and u1b denotes one-way, broadcast-type connectivity.

- Short range wireless infrastructure for short-range information transfer (also many data flows, but limited to specific applications). This infrastructure would typically be dedicated to ITS uses. The wireless interface to this infrastructure is referred to as u2, denoting a short-range airlink used for close-proximity (typically less than 50–100 feet) transmissions between a mobile user and a base station, typified by transfers of vehicle identification numbers at toll booths.
- Dedicated wireless system handling high data rate, low probability of error, fairly short range, Automated Highway Systems related (AHS-related) data flows, such as vehicle to vehicle transceiver radio systems. This wireless interface is denoted by u3. Systems in this area are still in the early research phase.

The ITS network reference model has to be tied to the specific interconnections between the transportation systems or subsystem, e.g., connection between Information Service Provider (ISP) subsystem and a vehicle subsystem (VS). The key step is performed through the Architecture Interconnect Diagram (AID), actually, a whole collection of them of varying levels of detail. These marry the communication service requirements (which are generic information exchange capabilities such as messaging data) to the data flow requirements in the transportation layer, and specify the type of interface required (u1, u2, u3, w). The Level-0 AID is the top level diagram showing the types of interconnectivities between the various transportation subsystems, and, perhaps, is the best description of the communication framework in the ITS architecture. The AID Level-0 is broken down further to show subsets of it depicting the data flows that, say, use broadcast (u1b), or those that use either broadcast or two-way wide area wireless (u1t).

Various media and media types are applicable as possible candidates for each type of interconnection. The best communication technology family applicable to each data flow is specified. This still remains above the level of identifying a specific technology or system. In practice, i.e., in a real-world ITS deployment, the final step of selecting a given technology would be performed by the local ITS implementor or service provider. A proffered specification here would clearly transcend the boundaries of architecture and into the realm of system design. It is therefore avoided to the extent possible in the communication architecture definition phase.

To assist the implementors and service providers in the ITS community, a broad technology assessment is performed. It attempts to use as much factual information as is available to identify and compare key pertinent attributes of the different communication technologies from a National ITS perspective. This, at least, facilitates the identification of which technologies are suitable for the implementations of what data flows.

A host of land-mobile (i.e., cellular, SMR, paging, etc.), FM broadcast, satellite, and short range communication systems have been assessed. The assessment addresses the maturity of the candidate technologies and analyzes their capability for supporting ITS in general, and the architecture in particular. Within the limits of reliable publicly available information, the following attributes are assessed: infrastructure and/or service cost as applicable, terminal cost, coverage, and deployment time-line (if not yet deployed). Furthermore, interface issues (i.e., open versus proprietary) are also addressed from a national ITS perspective. Whenever possible,

analysis is performed to determine: 1) system capacity, i.e., supported information rate, 2) delay throughput, 3) mobility constraints, etc. The ITS Architecture data flow specifications are used in the analysis, including message sizes and update frequencies. The key comparison characteristics are finally summarized in tables.

Another area focus in this document is ITS communication performance evaluation. The objective is to determine whether the National ITS Architecture is feasible, from the standpoint that communication technologies exist and will continue to evolve to meet its demands, both technically and cost effectively. To set the stage for this, data loading analyses have been completed for the wide area wireless interfaces u1t, u1b, and the wireline interface w-- data loading for the u2 and u3 interfaces is not as useful, so link data rates have been determined instead.

The data loading analyses define all of the messages that flow between all of the physical subsystems. Deployment information from the evolutionary deployment strategy has been used to define which services, and therefore which messages would be available for each of the scenario and time frames specified by the Government. The three scenarios provided are addressed, namely, Urbansville (based on Detroit), Thruville (an inter-urban corridor in NJ/PA), and Mountainville (a rugged rural setting based on Lincoln County, Montana).

Seven user service groups with distinct usage patterns have been defined, along with the frequency of use of the messages by each user group. Messages have been assigned to the u1t, u1b, and w interfaces based on suitability, and are allowed to flow over multiple interfaces with a fraction assigned to each one. The resulting data loading analyses provide the data loads and a complete description of the message statistics, on all of the above interfaces and links. These data are used to drive the communications simulations.

For the u1t interface (two way wide area wireless), the data loading results indicate that for Urbansville in 2002 the largest data loads result from the CVO-local user service group, followed closely by transit and private vehicles. In Thruville, for the same time period, CVO-local and transit are alone the largest data users. For Urbansville in 2012, private vehicle and CVO-local are the largest data users, at about twice the rate of transit, with the others far below. For Thruville in 2012, CVO-local remains the largest data user, followed by transit. The Mountainville data loads are very low, with CVO-local the largest user, followed by private vehicles.

In each of the u1t scenarios and time frames studied the forward direction data load (center to vehicle) is always higher than the reverse direction load, by a factor of two to three. The consistent users of the reverse direction are CVO and transit.

The ITS Architecture data loading results have been used as input to the communication simulations. Due to the relative scarcity of wireless communications (relative to wireline), emphasis has been placed on the evaluation of wireless system performance. However, network end-to-end performance, comprising both the wireless and wireline components, given in terms of delay and throughput, is also obtained. Furthermore, representative analyses of wireline networks have also been included.

The wireless simulations performed were for Cellular Digital Packet Data (CDPD), primarily because it is an open standard with a publicly available specification, and because validated, state-of-the-art simulations were made available for use on the ITS Architecture Program. These simulations accurately reflect the mobile system conditions experienced in the real world, including variable propagation characteristics, land use/land cover, user profiles, and interference among different system users (voice and data). The simulations also handle the instantaneous



fluctuations and random behavior in the data loads whose peak period averages are derived in the data loading analysis sections. The simulation modeling tools have been tested and validated in the deployment and engineering of commercial wireless networks by GTE.

Simulations have been run for the three scenarios provided by the Government. Since the number of users is very small in Mountainville, only cellular coverage was obtained to ascertain its adequacy in that remote area. For both Urbansville and Thruville, scenarios with both ITS and Non-ITS data traffic projected for the CDPD network were run, under normal peak conditions and in the presence of a major transportation incident.

The Government-provided scenario information was substantially augmented with information on actual cellular system deployment obtained directly from FCC filings. A minor amount of radio engineering was performed to fill a few gaps in the information obtained. The commercial wireless deployment assumed in the simulation runs, therefore, is very representative of the real operational systems. In fact, because of the continuous and rapid expansion of these systems, the results of the simulations are worst case in nature.

The wireless simulation results have shown that the reverse link delay (the data sent from the vehicle to the infrastructure), even in presence of non-ITS data, and in the case of an incident during the peak period, is very low (150 ms for ITS only; 300 ms for ITS plus non-ITS; with a 10% increase in the sectors affected by the incident).

The results of the CDPD simulations are further validated by the results of an operational field trial that was performed in the spring of 1995, jointly by GTE and Rockwell, in the San Francisco Bay Area. The application demonstrated was commercial fleet management (dispatch), using GPS location, and CDPD as an operational commercial wireless network. A synopsis of the trial and its results are presented in an Appendix.

The above results for CDPD should be interpreted as a "proof by example". A commercial wireless data network is available today to meet the projected ITS requirements. Other networks also exist, and can be used, as indicated in the technology assessment sections. Future wireless data networks, and commercial wireless networks in general, will be even more capable.

The simulation results for the wireline network example deployment indicate that extremely small and completely insignificant delays are encountered, when the system is designed to be adequate for the projected use. With the capacities achievable today with fiber, whether leased or owned, wireline performance adequacy is not really an issue. The key issues there pertain to the costs of installation versus sustained operation for any given ITS deployment scenario.

The overarching conclusion from the communication system performance analyses is that commercially available wide area wireless and wireline infrastructures and services adequately meet the requirements of the ITS architecture in those areas. These systems easily meet the projected ITS data loads into the foreseeable future, and through natural market pull, their continued expansion will meet any future ITS growth. Hence, from that particular standpoint, the National ITS Architecture is indeed sound and feasible.

This National ITS Communication document also contains additional analyses to support some of the architectural decisions taken during the course of the project, and reflected in the architecture definition. One such decision is avoiding the use of dedicated beacon systems for wide area applications, such as traveler information, route guidance, mayday and so on. The technical and economic drivers are addressed in an appendix and synopsized in the technology assessment section.

# 1. INTRODUCTION

## 1.1 Purpose of Document

In the information age, the world of telecommunications is indeed very large, with many diverse systems and technologies, offering a very broad range of capabilities and features. This world is evolving and expanding rapidly. On the other hand, the world of ITS is also broad, and complex. This is amply demonstrated by the many ITS user services, and their myriad interactions and possibilities.

The National ITS Architecture can be viewed as a framework that defines the interactions between the transportation and telecommunication domains that enable the creation and offering of the ITS user services throughout the nation. This architectural framework thus encompasses various transportation systems with many information flows among them. It also encompasses various choices of telecommunication services and media needed to carry this information and to ensure the proper connectivity between the transportation systems involved. The ITS Architecture, through its structure, aims to mitigate the complexity involved in dealing with so many entities. One of its basic concepts is the decoupling of the transportation and telecommunication domains into two, fairly independent, yet tightly coupled “layers”.

This National ITS Architecture Communications document presents, under a single cover, a comprehensive, cohesive treatment of communications within the National ITS Architecture. This comprises two broad, major thrusts: 1.) communication architecture definition (also referred to as the definition of the “communication layer” of the ITS Architecture); and 2.) analysis of communication systems performance to meet the connectivity and data loading requirements of the ITS Architecture. The objective of this analytical thrust is to demonstrate the feasibility of the architectural decisions made in the definition of the communication layer and to present the key supporting tradeoffs. This feasibility is from the standpoint that communication technologies exist and will evolve to continue to meet the architecture’s demands in a predictable, cost effective manner. The communication analysis thrust thus includes:

- A comprehensive analysis of the data loading requirements of the architecture for different scenarios and time frames.
- A balanced assessment of a wide array of wireless and wireline communication techniques and systems applicable to the ITS Architecture.
- An in-depth, quantitative performance evaluation of specific example system implementations.
- A compilation of the supporting technical and economic telecommunication analyses.

This document is intended to provide both the telecommunication and transportation engineer, i.e., the specialist and non-specialist engineer, with all the details pertinent to the definition of the

ITS communication architectural framework and all its supporting analyses. To achieve this formidable objective, the document is divided into nine sections and 10 supporting appendices. This two-tier structure allows for an accessible presentation of the over-arching communication definition issues and analysis results, yet does not sacrifice much of the in-depth, detailed developments essential to arriving to the main findings presented in the nine sections.

This document was prepared for the Rockwell and Loral Teams – and for the ultimate customer, the FHWA – by a team of telecommunication engineering specialists from GTE Laboratories. Work was performed in close collaboration with Rockwell, Loral and the other members of the Architecture Development and Government teams. This development environment ensured a treatment of ITS communication that balances the real-world experience from the telecommunications industry with the broader perspective, and distinct needs, of the transportation community.

## 1.2 Structure of Document

This document consists of nine sections and 10 appendices. The contents of each section and appendix is briefly described below.

---

<b>Section 1</b>	<b>Introduction</b>
	Introduction to the document.
<b>Section 2</b>	<b>Introduction to the ITS Communications Architecture</b>
	An introduction to the ITS Communications Architecture in a concise tutorial. This section also presents the philosophical approach and the objectives of the communications architecture, and its relationship to the evaluatory design analyses.
<b>Section 3</b>	<b>Communication Architecture Definition</b>
	A complete description of the Communication Architecture, including definitions of terms, communication services, and a description of the linkage of the communication and transportation layers through the Architecture Interconnect Diagrams (AID's).
<b>Section 4</b>	<b>Scenarios and Time Frames</b>
	Presents information on the evaluatory design, with baseline information for the scenario regions, number of potential users by group, penetrations, and usage profiles.
<b>Section 5</b>	<b>Message Definition</b>
	Describes the message definition methodology starting from the logical architecture, and introduces the structure adopted for the messages, and the message set.
<b>Section 6</b>	<b>Data Loading Methodology and Results</b>
	Provides an analysis of the data loading requirements and results for both wireless and wireline communication based on the architecture definition.
<b>Section 7</b>	<b>Assessment of Communications Systems and Technologies</b>
	A comprehensive analysis and assessment, from a National ITS Architecture perspective, of a wide array of applicable communication systems. Analysis approach, results and summary tables.

---

<b>Section 8</b>	<b>Communication Systems Performance – A Case Study</b> An in-depth, quantitative performance analysis, using state-of-the-art simulations, of specific wireless and wireline system implementations of the ITS Architecture. Includes wireless, wireline and end-to-end communication system performance.
<b>Section 9</b>	<b>ITS Architecture Communication - Conclusions</b> The conclusions and salient findings of this report.
<b>Appendix A</b>	<b>Communication Architecture Development and Definitions</b> The definitions of the pieces comprising the communication architecture.
<b>Appendix B</b>	<b>Architecture Interconnect Diagrams – Level 1</b> The interconnections and data flows are represented in a detailed Level 1 AID format.
<b>Appendix C</b>	<b>Communication Architecture Renditions and Applicable Technologies</b> Describes the development of the Communication Architecture Renditions (classes of communication system implementations-- not specific technologies, for the architecture).
<b>Appendix D</b>	<b>Technology Assessment Sources</b> Provides a compilation of the many sources, printed and electronic, that were used in establishing the technology assessment.
<b>Appendix E</b>	<b>Potential Users According to User Service Group</b> Analysis of potential buyers for each user service group.
<b>Appendix F</b>	<b>Message Definitions and Data Loading Models</b> Presents the message definitions and data loading models listed by user service group for each scenario.
<b>Appendix G</b>	<b>Use of Beacons for Wide Area Delivery/Collection of ITS Information</b> Examines alternative architectures in which services are provided by wireless dedicated short-range communication (DSRC) between vehicles and roadside beacons.
<b>Appendix H</b>	<b>Wireless and Wireline Protocols</b> Descriptions of wireless and wireline protocols, primarily for the systems analyzed .
<b>Appendix I</b>	<b>Simulation Tools</b> Describes the wireless and wireline simulation tools used in the communication analysis.
<b>Appendix J</b>	<b>CDPD Field Trial Results</b> Presents a synopsis of the results of a CDPD field trial for an ITS application.

## **2. INTRODUCTION TO THE ITS COMMUNICATION ARCHITECTURE**

### **2.1 Role of the Communication Architecture**

The complex world of telecommunications is evolving and expanding rapidly. The ITS world is also broad and quite varied, as demonstrated by the ITS user services, their distinct needs, and the complex interactions and synergies. The National ITS Architecture can be viewed as a framework that ties together the transportation and telecommunication worlds. This framework enables the creation and effective delivery of the broad spectrum of ITS services.

For the transportation engineer and planner, myriad communication options are available to consider. The telecommunication solutions meet the transportation requirements at hand with varying results and implications of performance, cost, and user acceptance. There are also many challenges in interconnecting the disparate components of any end-to-end ITS solution, encompassing various transportation and communication issues.

Throughout the Architecture effort, the emphasis has been on flexibility. This allows the local implementors and service providers to select the specific technologies, within the framework of the architecture, that best meet their needs (expressed either in terms of market or jurisdictional constraints). The price paid in the architecture is some added complexity. It has been critical, therefore, to espouse an architectural concept that mitigates the complexity of interconnecting many transportation systems with multiple types of communication links.

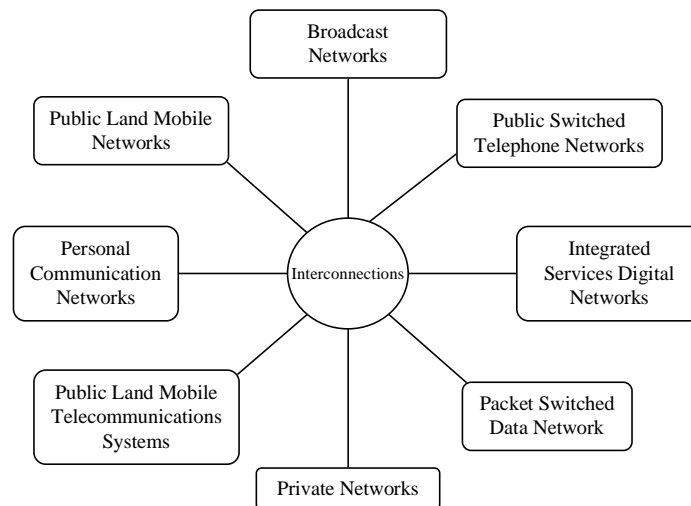
The basic architectural concept, wherein the Physical Architecture has a Transportation and a Communication Layer, is specifically intended to simplify the process by separating these two fairly independent domains. At the same time, the two domains should be tightly coupled to meet the ITS users' service requirements. Through this unified, logically derived, and structured framework, the interconnectivity requirements between the transportation systems can be drawn from the ITS user services. Then, various communication choices can be considered and objectively evaluated for their ability to meet those connectivity requirements. Furthermore, the structure of the communication architecture is designed to facilitate the identification of the critical communication technology interoperability and interface issues. In so doing, these issues can be addressed and resolved in order to facilitate the deployment of ITS on a national scale.

The communication layer of the ITS physical architecture, therefore, aims to provide answers for the following questions:

- What types of communication infrastructures are required to connect the transportation subsystems to enable a given set of ITS user services?
- What types of communication services (information transfer capabilities) are needed to carry the information that flows between the transportation subsystems services (i.e., the ITS data flows) in order to provide the ITS user?
- What modes of communication connectivity (packet, circuit, etc.) are required for the various ITS data flows?
- What types of communication systems, or technology classes, are available to meet these communication requirements (which are driven by the ITS user service requirements)?
- How do these candidate communication solutions compare from the perspective of meeting the goals of the National ITS Architecture?
- In light of the many available candidates, what are the critical points of communication systems interface that may need to be standardized to enable national interoperability?

## 2.2 The Telecommunication Infrastructure and the ITS Communication Architecture Development Philosophy

Over the last two decades, a massive telecommunication infrastructure has evolved, both for wired and wireless communication. The reliability and capacity of wireline networks has increased exponentially, enabling a wide array of new services and capabilities. At the same time, prices of most wireline telecommunication services which are subject to competition have dropped remarkably. The wireless arena, on the other hand, was born and has since witnessed unprecedented growth. As an example, roughly \$20 billion has been invested in the cellular infrastructure until 1995. The wireless industry, in its varied incarnations, now holds tremendous promise into the future, as evidenced by the fierce competition for its spectrum and the value attached to it. In fact, wireless's predicted growth may alter many of the traditional paradigms of communication. Today, wireline and wireless networks can take various forms, public and private, as depicted conceptually in Figure 2.2-1.



**Figure 2.2-1 Overview of the Telecommunications Arena**

Over the next twenty years, many new communication technologies and techniques, from multiple access to transport to switching, will be introduced at a rapid pace to support the demands of our information age. Presently available and emerging technologies will offer extensive opportunities to handle many ITS user services. The technology projections depicted in Table 2.2-1 identify the predicted availability of various communication technologies and infrastructures that could be exploited.

The natural competitive evolution of wireline and wireless infrastructures will yield communication systems that will:

1. Support communication services which include: voice (speech), data, image, video, and signaling.
2. Accommodate a wide variety of terminals, i.e., fixed, portable mobile, and in-vehicle mobile.
3. Preserve upward/downward terminal compatibility.
4. Allow mobile and fixed users to utilize the services regardless of geographical location (i.e., seamless communication).
5. Provide service flexibility, so that any combination of services may be used.
6. Make efficient and economical use of the spectrum.
7. Provide user authentication and billing functions.
8. Provide varied degrees of network security that preserve user privacy.
9. Have modular structures which will allow the systems to start from small and simple configurations then grow as needed in size and complexity.
10. Use, in many cases, open architectures which will permit the easy introduction of technology advancement and support of new applications.

As a reflection of the very desirable attributes delineated above, one of the fundamental guiding philosophies in developing the National ITS Architecture has been to leverage, to the extent possible, the existing and emerging telecommunication infrastructures. Doing so not only benefits ITS from the tremendous financial investment in the deployed and planned infrastructures, but also from the large time and effort expended in developing standards to allow interoperability and interconnectivity among disparate systems. Moreover, this enables the ITS users to share many of the scarce and valuable resources, and distribute their cost over a significantly broader population.

By embracing the heritage of the broad telecommunications industry, the cornerstone of whose success has been fulfilling users' needs and meeting with their acceptance, ITS will be on the proper path towards a wide scale presence. This evolutionary approach is essential to maximizing the feasibility of the architecture, and to mitigate the risk inherent in creating and offering intelligent transportation systems, services, and products, all of which are quite new and in need of acceptance.

**Table 2.2-1 Communications Technology Projections for the Next 15 Years**

<b>Technologies</b>	<b>1992</b>	<b>1997</b>	<b>2002</b>	<b>2012</b>
Wireless Access	FDMA Analog	FDMA and TDMA/CDMA Digital	CDMA/TDMA Digital	Mainly CDMA Digital
Wireless Capacity	Moderate	High (3-5x AMPS)	High (5-10x AMPS)	High (10-15x AMPS)
Wireless Signal Coverage	All Urban, Most Inter-Urban, Some Rural	All Urban and Inter-Urban, Most Rural	All Urban and Inter-Urban All inhabited Rural	Ubiquitous
Wireless Media • Terrestrial: • Satellite:	Most Macro Limited GEO	Full Macro, Initial Micro Some GEO, Initial LEO	Full Macro, Most Micro Full GEO, Partial LEO	Transparent, Hybrid Terrestrial Satellite Integrated Macro/Micro Full GEO/ Full LEO
Wireline Availability	Widespread Copper Limited Fiber for LAN's and Backbone	Fiber Backbone with Copper Drops Very Limited Hybrid Fiber-Coax	Limited Fiber to Curb Some Hybrid Fiber-Coax	Partial Fiber to Curb Limited Fiber to Home
Transfer Mode	Full Circuit-Switching Packet-Switching Initial Frame-Relaying	Partial Frame-Relaying Very Limited Asynchronous Transfer Mode (ATM)	Most Frame-Relaying Initial Fast-Packet Switching Partial ATM	Most Fast-Packet Switching Most ATM
Data Protocol	X.25, X.21	Frame-Relay ATM	Frame-Relay ATM	Mostly ATM
Transport Network Characteristics	Service Dependent Disconnected LAN's Slow Speed Interconnection	Initial Service-Independent Initial LAN Connectivity through Metropolitan Area Networks (MAN)	Partial Service-Independent Partial MAN's	Widespread Service Integrated Broadband Network—B-ISDN Most Service Independent
Intelligent Network Characteristics	Partial Wireline Support: • Number Translation	Most Wireline Support Partial Wireless Support • Mobility Services (Personal, Terminal)	Full Wireline Support Most Wireless Support	Fully Integrated Wireline/Wireless Support • Seamless Operation • Multi-Mode Terminal • Profile Portability • Dynamic Resource Allocation • Information Format Adaptation



### **2.3 Development of a Communications Architecture**

The development of a communication architecture comprises a set of steps which, more or less, parallel those of a generic system architecture. A few basic steps can be identified. The first is the development of the communication services description, using widely accepted description conventions. (Communication services are generic information transfer capabilities, such as conversational speech or messaging data). The detailed definition of the communication service is based on the communication needs to be fulfilled. This first step is analogous, in some sense, to the development of the ITS user services. (Note that from a communication architecture perspective, the ITS user services are applications; this is explained in considerable detail in Section 3.) The second step in the development of a communication architecture is determining the network's logical functions (e.g., wireless access, registration) to meet the requirements of the communication service. This step is analogous to the definition of the logical architecture. The third step, which is equivalent to the physical architecture, has two elements, the first is the identification of the functional entities (e.g., switch, base station) that can be used to perform the logical functions, and the second is matching those functional entities to established or revised network reference models, which identify reference interfaces between the physical equipment (standards are usually written for those reference interfaces.)

This framework has been used often, in developing new telecommunication services and systems with open specifications, such as cellular (AMPS, GSM, CDMA, CDPD, etc.), PCS, and others. It has also been used extensively in developing inter-system operation and interface standards. This structured, generic methodology will be followed in defining the communication architecture for ITS, but will be adapted and extended to meet the distinct needs of the various ITS user services. The network reference model approach is very well suited to the ITS architecture needs, where particular importance is attached to the identification of key inter-operability interfaces and their standards requirements.

### **2.4 Elements of the Communications Layer of the ITS Architecture**

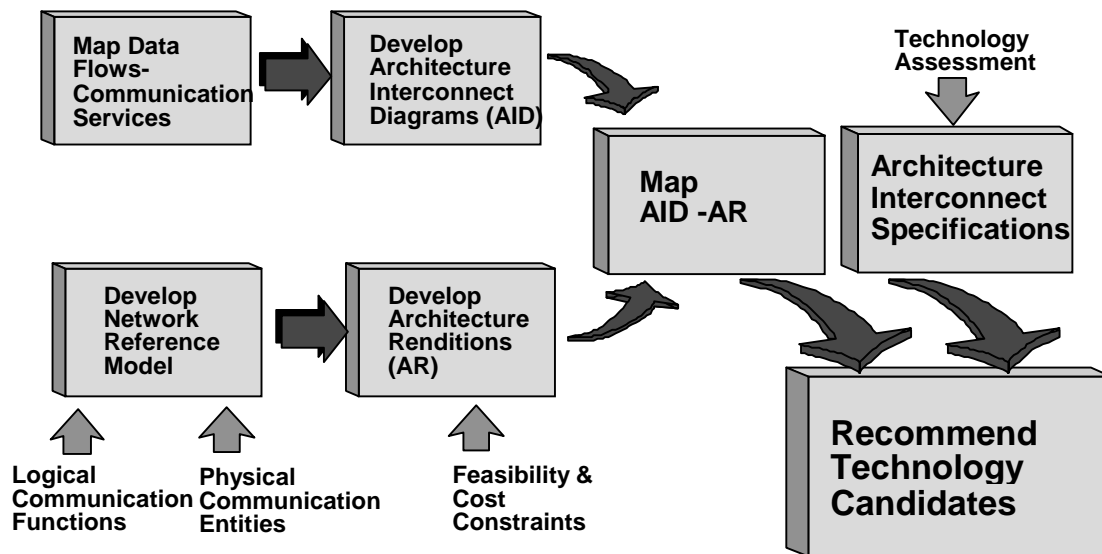
The communication architecture provides information transfer for the transportation layer subsystems. The communication architecture includes all of the communications entities, i.e., wireline and wireless transmitters, receivers, satellites, etc., and the information management and transport capabilities necessary to transfer information among the transportation entities. The application data content and the transportation application requirements are, in general, transparent to the communications architecture. The communications architecture's view of the transportation layer is that of many distributed users, some of them mobile, which require information transfer services.

The communication architecture must be technically and economically feasible as well as sensitive to the potential institutional and regulatory barriers. Because of the variances in the ITS user service requirements (from a communication perspective), it is clear from a cursory examination that the user services do not share a common information transfer capability. Specifically, some ITS user services will be best served by leveraging commercial telecommunication infrastructures that provide services to users and applications that transcend ITS, others will require specialized, dedicated communication systems. The differences in these architectural choices can lead to dramatic differences in cost, deployability, risk of acceptance and performance.

The communication architecture definition, then, entails the appropriate selection of communication services, communication media and interface types, communication technology groups (with common salient attributes) to interconnect the appropriate transportation systems.

The steps for developing the communication architecture are depicted in Figure 2.4.-1. The lower branch to the left is basically the generic communication architecture development process. The upper branch, and the rest of the steps, represent the transportation/ communication linkage process through which a generic communication architecture becomes tailored to the specific needs of the ITS architecture, driven by the requirements of the ITS user services. This linkage is accomplished through the following steps:

1. Mapping the generic communication services to the data flows identified in the Transportation Layer.
2. Generating the Architecture Interconnect Diagrams (AIDs) which define the interconnections between transportation subsystems and modules defined in the Transportation Layer.
3. Identifying the Architecture Renditions (ARs) which are examples, based on the network reference model, of how to provide communication technology groups to provide connections between users defined in the Transportation Layer.
4. Mapping of the AIDs to the AR's (each AR stays one level above technology specification, and comprises a family of systems with similar attributes, e.g., wireless packet data networks).
5. Identifying the Architecture Interconnect Specifications (AISs) which are examples of specific systems to implement an applicable communication technology to a particular rendition, for example, the use of CDPD for cellular wide-area wireless data communication.



**Figure 2.4-1 Communication Architecture Development Process**

Within the AIS, various media and media types are applicable as possible candidates for each interconnection. The best communication technology family applicable to each data flow is specified. This definition remains one level above that of identifying a specific technology or system. In practice, i.e., in a real-world ITS deployment, the final step of selecting a given

technology would be performed by the local ITS implementor or service provider. A proffered specification transcends the boundaries of architecture and into the realm of system design. It is therefore avoided to the extent possible in the communication architecture definition phase.

To assist the implementors and service providers in the ITS community, an extensive and broad technology assessment is performed subsequent to the architecture definition. It attempts to use as much factual information as is available to identify and compare key pertinent attributes of the different communication technologies from a National ITS perspective. This, at least, facilitates the identification of which technologies are suitable for the implementations of what data flows.

## **2.5 Relationship of the Communication Architecture Definition to the Data Loading Analysis and Simulations**

From a National ITS Program perspective, the ITS architecture development activities in the area of communication encompass two broad thrusts: 1) communication architecture definition, i.e., selection of communication service and media types to interconnect the appropriate transportation systems, and 2) several types of inter-related communication analyses, to ensure the feasibility, and soundness, of the architectural decisions made in the definition. The feasibility is from the standpoint that communication technologies exist and will continue to evolve to meet the demands of the National ITS Architecture, both technically and cost effectively.

The analyses performed comprise:

- An analysis of the data loading requirements derived from the ITS service requirements, the Logical and Physical Architectures and their data flows, the ITS service deployment timeline, and the attributes of the candidate scenarios in the “evaluatory design”, developed based on Guidance provided by the Government.
- A wide-ranging, balanced assessment of a broad spectrum of communication technologies that are applicable to the interconnections defined in the communication layer of the Physical Architecture. The evaluation is performed from a National ITS Architecture standpoint.
- An in-depth, quantitative analysis of the real-world performance of selected technologies that are good candidates for adoption as ITS service delivery media, and for which reliable, state-of-the-art simulation tools are available. The performance is determined under the demands of the ITS and other projected applications of the media.
- Supporting technical and economic telecommunication analyses that address some important architecture-related issues, such as the appropriate use of dedicated short range communication (DSRC) systems.

The data loading analyses define all of the messages that flow between all of the physical subsystems. Deployment information from the evolutionary deployment strategy is used to define which services, and therefore which messages would be available for each of the scenario and time frames specified by the Government. The three scenarios provided are addressed, namely, Urbansville (based on Detroit), Thruville (an inter-urban corridor in NJ/PA), and Mountainville (a rugged rural setting based on Lincoln County, Montana).

User service groups with distinct usage patterns are defined as are the frequency of use of the messages by each user group. Messages are assigned to the different interfaces defined in the architecture definition, specifically, the ITS network reference model, based on suitability. The

results provide the data loads on all of the different interfaces and links, with a complete description of the message statistics, which are used to drive the communications simulations.

The communication simulations take the quantitative analysis of the evaluatory design one step further. They use validated, state-of-the-art simulation models to determine the real world performance of select communication systems when used to carry the data loads derived from the ITS architecture definition. The instantaneous variations and random behavior of the average loads for the peak periods derived in the data loading analysis are handled by these sophisticated simulations. The example systems simulated are among the candidate technologies identified in the architecture definition and are determined to be strong contenders in the broad technology assessment performed.

The results sought from the wireless and wireline simulations are intended to serve as “proof by example”. That is, certain viable communication systems, for example commercial wireless data networks, are available today to meet the projected ITS requirements (for a certain set of data flows). Since future systems will only be significantly more capable than today’s, favorable performance results obtained for future time frames, e.g., the year 2002, for present systems, would clearly indicate the soundness of the decisions made in the communication architecture definition.

### **3. COMMUNICATION ARCHITECTURE DEFINITION**

The overall ITS physical architecture consists of three layers: the Transportation Layer, the Communication Layer, and the Institutional Layer. This section presents an overview of the Communication Layer. It is divided into two main sections: Communication Architecture (Section 3.1), and Communication Layer linkage to the Transportation Layer (Section 3.2).

The Communication Architecture section (Section 3.1) first presents a top-level generic communication model which illustrates the basic relationship between the ITS Physical Architecture's Transportation and Communication Layers. This generic communication model, which should not be confused with the ITS communication network reference model, is based on the International Standards Organization's (ISO) Open Systems Interconnection (OSI) model. The ISO OSI model consists of seven layers: application, presentation, session, transport, network, data link, and physical layer. In general, the application, presentation, and session layers are supported by the Transportation Layer while the transport, network, data link and physical layers are supported by the Communications Layer.

The Communication Architecture Section (Section 3.1) also provides definitions of the various components that make up the communication layer. Some of these components include: communication services, communication logical functions, communication functional entities, and communication network reference model. The communication network reference model is the primary ITS communication model.

The communication architectures for commercial communication systems such as Personal Communication Services (PCS), Groupe Speciale Mobile (GSM), TIA-IS-41, Cellular Digital Packet Data (CDPD), to name a few, use communication network reference models. A network reference model is used to identify physical equipment that perform communication functions, and is used to identify reference interfaces between these physical equipment (standards are usually written for these reference interfaces). The ITS network reference model is based on, and presents extensions of, several reference models that were developed for the above mentioned standard communication systems. The model provides a structure that shows how various communication technologies can implement the ITS Architecture Interconnect Diagrams (AIDs), which are presented later in the Communication Layer Linkage Section (Section 3.2).

The Communication Layer Linkage section also identifies the relationship between the Transportation Layer and Communication Layer definitions. This is accomplished through the following steps:

1. Mapping the communication services to the data flows identified in the Transportation Layer.
2. Generating the Architecture Interconnect Diagrams (AIDs) which define the interconnections between transportation subsystems and modules defined in the Transportation Layer.
3. Identifying the Architecture Renditions (ARs) which are examples, based on the network reference model, of how to provide communication connections between users defined in the Transportation Layer.
4. Mapping of the AIDs to the AR's (each AR stays one level above technology specification, and comprises a family of systems with similar attributes, e.g., wireless packet data networks).
5. Identifying the Architecture Interconnect Specifications (AISs) which are examples of specific systems to implement an applicable communication technology to a particular rendition, for example, the use of CDPD for cellular wide-area wireless data communication.

To summarize, the Communication Layer Linkage Section presents the communication services/data flow mapping, AIDs, ARs, AID/AR mapping, and AISs.

In general, the Communication architecture for ITS will have two components: one wireless and one wireline. All Transportation Layer entities requiring information transfer are supported by one or both of these components. In most cases, the wireless component merely provides a tetherless user, usually one in a vehicle, with access to fixed (or wireline) network resources. The wireless portion will be manifested in three different ways:

- Wide-area wireless infrastructure supporting wide-area information transfer (many data flows). For example, the direct use of existing and emerging mobile wireless systems.
- Short range wireless infrastructure for short-range information transfer (also many data flows, but limited to specific applications), similar to systems used for electronic toll collection.
- Dedicated wireless system handling high data rate, low probability of error, fairly short range, Advanced Highway Systems related (AHS-related) data flows, such as vehicle to vehicle transceiver radio systems.

Because of the variances in the ITS user service requirements (from a communication perspective), it is clear from a cursory examination that the user services do not share a common information transfer capability. Specifically, ITS user services like electronic toll collection demand communication needs that can only be met by dedicated infrastructures for technical and feasibility, notwithstanding institutional, reasons. The ITS user services information transfer needs are supported by a sample deployment of the communication network reference model described in Section 3.1.4. Implementation candidates are identified as a result of a broad, balanced communication technology assessment task. After examining the assessment results for these candidates, an ITS implementor or service provider can decide on the mix of communication technologies that are best suited to the implementation scenario at hand.

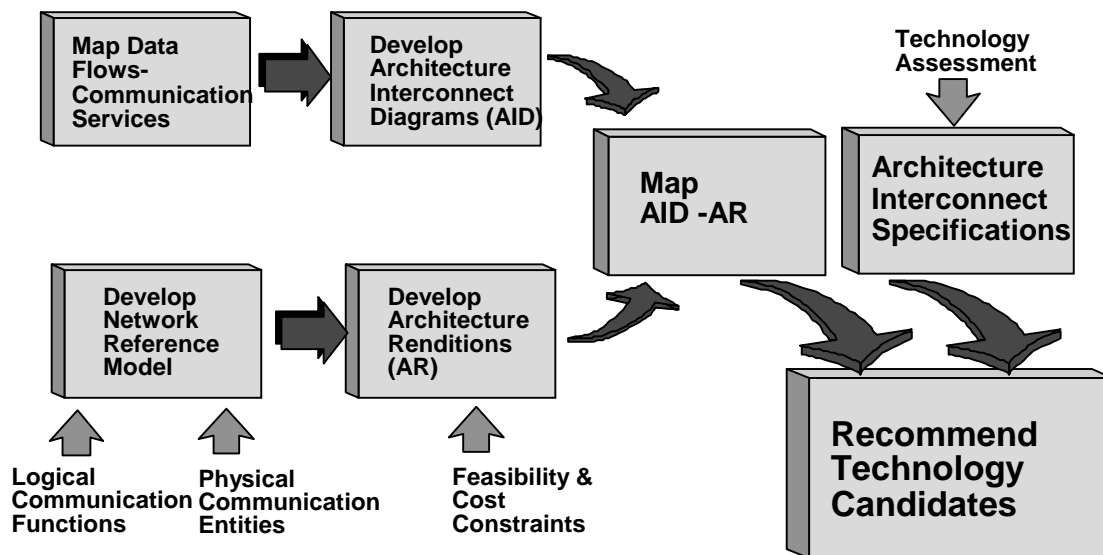
The wireline portion can be manifested in many different ways, most of them implementation dependent. Note that in defining the Communication Layer, no assumptions have been made regarding media type.

The process of developing the communications layer (architecture) is illustrated in Figure 3.0-1, and starts from the data flows in the transportation layer. In the following sections, the reader is referred to this figure at each step of the design process description.

The upper left block in Figure 3.0-1 shows the mapping of the identified data flows to communication services. The data flows are derived from the Architecture Flow Diagram (AFD) provided in the Physical Architecture document, which is used to specify which transportation subsystems communicate directly with each other. The communication services are described in Section 3.2.1 in terms of flow response and capabilities. (They should not be confused with the ITS user services, which from a communications standpoint, are applications. These will be discussed shortly.) The mapping provides one or more communication services for each of the data flows between transportation entities. The Architecture Interconnect Diagrams (AIDs) encapsulate the type of partition between each of the transportation layer subsystems as wireline or wireless. This is accompanied by a description of the communication service and operation mode for all the data flows between each pair of entities.

In parallel, a Network Reference Model (lower left block in Figure 3.0-1) is derived from models for standard commercial communication systems to fit ITS needs. This communication model is then used, in combination with feasibility and cost constraints, to develop renditions, or examples, of how to realize the required communication services. These renditions are based on the communication interface type, and are one level above specific technology.

As shown in Figure 3.0-1, the MAP AID-AR block is done in an abstract way, identifying which data flows are supported by each rendition. At the same time, the results of the Technology Assessment are used to develop Architecture Interconnect Specifications, which identify and assess specific features of the technology which are important to interconnecting the transportation layer entities. The AIS involves further specification of the renditions, and completes the description of the ITS Communications Architecture. To illustrate, mobile wireless packet data networks are considered a rendition. Several technologies, like CDPD, RAM, and so on, are specific technologies that belong to this rendition that could be used in the implementation. The AIS section here is kept brief, and includes a few examples of the results of the communication technology assessment (from an ITS architecture standpoint) which is summarized in Chapter 7 and detailed in Appendix D. The AIS leads to technology recommendations, to be interpreted as implementation examples of the communication elements in the ITS architecture. In a real-world ITS implementation, this last step would be performed by the communication system designer.



**Figure 3.0-1 Communications Architecture Development Process**

### 3.1 Communication Architecture

The generic communication hierarchical model presented in Figure 3.1-1 shows the relationship between the Transportation and Communication Layers. Each data user can be one entity in the Transportation Layer (e.g., the Information Service Provider Subsystem or Personal Vehicle Subsystem in an information exchange). The user does not care about and should not be concerned with the specifics of this information transfer layer. In fact, the Communication Layer can be viewed as plumbing that carries information from one user to another.

The complex makeup of the network is usually defined by system architectures developed to meet specific requirements, performance objectives, and socio-economic drivers. In the absence of crisp specifications and because of the jurisdictional-independence of this particular architecture, the end framework precludes the design of low level implementation details. However, to properly evaluate the communication architecture candidates, select technologies and detailed designs are recommended in an evaluatory design (see the later chapters of this document.)

The generic hierarchical communication model shown in Figure 3.1-1 follows the Open Systems Interconnection model which organizes the communication network in a highly structured format to reduce its overall design complexity. This model is structured as a series of layers each with the function of providing certain services to the layer above and capable of conversing with the corresponding layer at the other end of the link. Thus the high level layers (e.g., ITS application) are shielded from the actual implementation details of the communication services. Different networks can use layers different from the OSI model, such as the IBM SNA (Systems Network Architecture). When different protocols are used in different networks, an interworking function must provide the conversion between the protocols at the various levels.

The lowest layer in the OSI model is the physical layer (layer 1), which provides the transmission of bits over wires or radio links.

Layer 2 is the data link layer, which is concerned with making the link appear to the receiver as bit error-free as possible by implementing error detection and correction (EDAC) coding schemes in the transceiver. One example of this is the use of a cyclic redundancy code (CRC) to a block or frame of the data. When the data passes the CRC check at the receiver, the returned acknowledgment indicates whether re-transmission is needed.

Layer 3 is the network layer, which controls the operation of the network. Here, the key issue is routing packets, which are also used to generate billing information for the communications service provider (billing is tied to IP addresses).

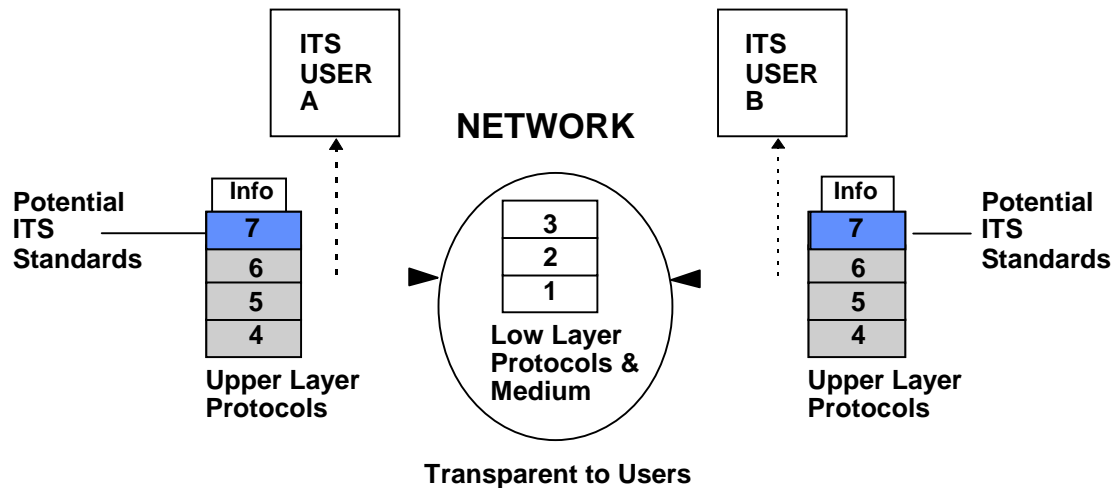
Layer 4 is the transport layer, which mediates between the session layer and the network layer, providing end-to-end accounting (sequencing, non-duplication, etc.) for all the data at the receiving end. It also isolates the top layers from the changing physical technologies.

Layer 5 is the session layer, which allows users on different machines to establish communications, or sessions, between them. This involves ordinary data transport but with enhanced services such as remote log-in or file transfer.

Layer 6, the presentation layer, performs syntax and semantic operations on the information transmitted between the users, such as encoding data in a standard way, or compressing or encrypting that data.

Layer 7 is the application layer, which provides commonly used protocols for such tasks as terminal emulation, file transfer, electronic mail and remote job entry. (Note that for many ITS applications, layers 5 and 6 are absorbed into the application layer, layer 7.)





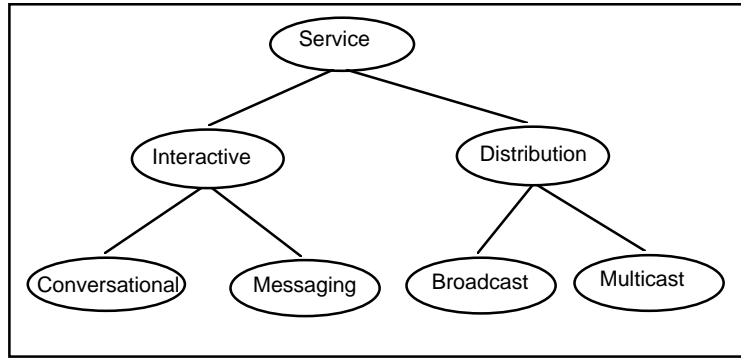
**Figure 3.1-1 Generic Hierarchical Communication Model**

From the Communication layer perspective, the term "services" is defined according to communications governing bodies (*e.g.*, ITU, TIA, etc.), and should be used with care. That is, when describing a communications architecture, one should not refer to Route Guidance or Pre-trip Planning as services. Rather, they are applications in need of a communication service. Elaborating more along these lines, ITS appears to the Communication Layer as a collection of applications with markedly different communication requirements. Thus the service provided by the communication model is characterized more by 1) the application's directionality requirements (*e.g.*, one-way or two-way) for information transport, 2) whether it is between mobile elements, mobile and stationary elements or stationary elements, 3) the amounts of data to be transported, and 4) the urgency rather than the precise description as Route Guidance or Pre-trip Planning.

The next section identifies various communication services to which the Transportation Layer data flows can be matched. Subsequently, a matching process will assign broad generic communication services to the ITS data flows without specifying a particular technology.

### 3.1.1 Communication Services

The communication services define the exchange of information between two points and are independent of the media and application (*i.e.*, ITS user service). In essence, they are a specified set of user-information transfer capabilities provided by the communication layer to a user in the transportation layer. Figure 3.1-2 illustrates the hierarchy of communication services. A brief description of the services is presented below; more detailed information is given in Appendix A.1.



**Figure 3.1-2 Communication Services Hierarchy**

Communication services consist of two broad categories, interactive and distribution. Interactive services allow the user to exchange data with other users or providers in real or near real time, asking for service or information and receiving it in the time it takes to communicate or look up the information.

Distribution services allow the user to send the same message to multiple other users.

Interactive services may be either conversational or messaging. Conversational implies the use of a two-way connection established before information exchange begins and terminated when the exchange is completed. Messaging, on the other hand, works more like electronic mail being exchanged between users. The messages are exchanged without establishing a dedicated path between the two sites. Each message is addressed and placed on the network for transmission, intermixed with messages from other users. The communications community labels this mode of communication a “datagram” service.

Distribution services may be either broadcast or multicast and may be used over wireline and/or wireless communication links. Broadcast messages are those sent to all users while multicast messages are sent only to a subset of users. Multicast differs from broadcast in its use of a designated address for all users and user groups. Examples of broadcast information might include current weather or road conditions, whereas multicast information might be information sent to all drivers working for a specific company. A changing group membership could be the set of users traveling between two locations or with a certain destination, for which unique information must be transmitted. The services that can be supported using circuit or packet connection mode include voice, video, image and data. (see Appendix A.1 for a complete description.)

Not shown in the Figure 3.1-2 are location services. These fall in two categories: (1) the services that do not use the communication network (i.e., GPS, and stand alone terrestrial systems); (2) location services that use the network for providing the service (e.g., cellular based systems). In the latter case, the location services fall under the interactive services. The service will be rendered by a service provider in response to a request for information or help. (See detailed description in Appendix A.1).

### **3.1.2 Logical Communication Functions**

Based on the objectives of the communication architecture, a list of logical functions to support the ITS system communication requirements are identified. The primary logical communication functions can be confined to: wireless and wireline access, switching, routing, registration authentication, interworking, validation, billing, and operations (see Appendix A.2 for a detailed description).

### 3.1.3 Functional Entities

The functional entities that make up the communication layer were derived from existing and emerging infrastructure specifications and standards (*e.g.*, TIA, ITU, Bellcore, ANSI). These basic building blocks form the foundation of a generic communication system. As with the transportation layer, each functional entity consists of one or more logical functions. These entities include: 1) user device, 2) user profile module, 3) switch, 4) wireless controller, 5) wireless base station, 6) interworking platform, 7) profile data base, and 8) wireline network. A detailed description of these functional entities is presented in Appendix A.3.

### 3.1.4 Communication Network Reference Model

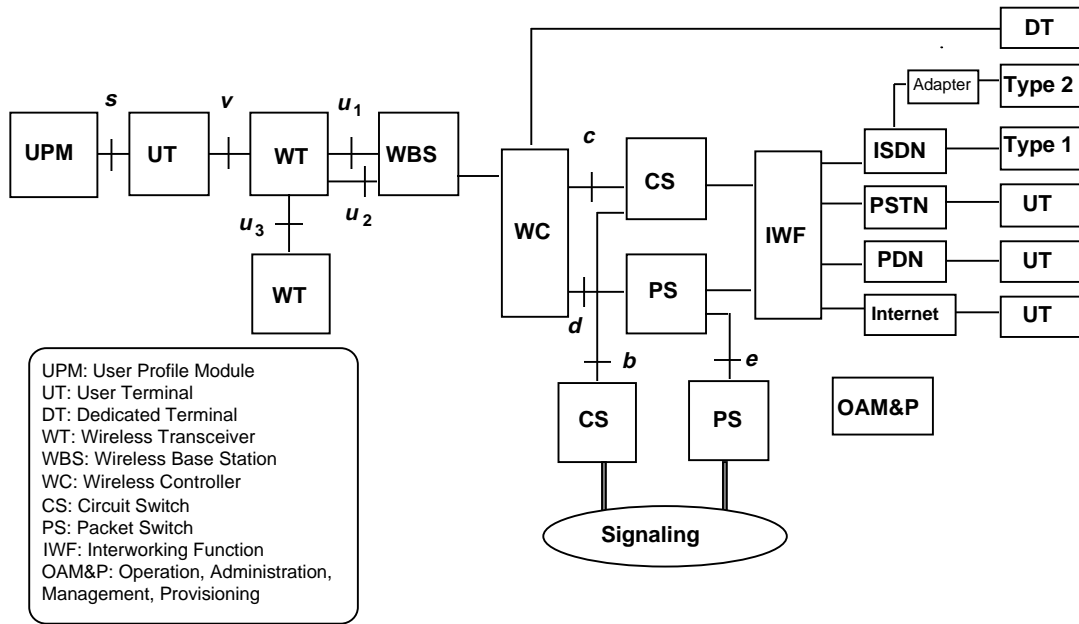
As shown previously in Figure 3.0-1, the communication architecture design process consists of several steps. The previous sections listed the communication logical functions and physical entities. The architecture design process now starts on the lower leg of Figure 3.0-1 with the development of the Communication Network Reference Model. This model provides an architecture or structure that shows how various communication technologies can implement the Architecture Interconnect Diagrams developed in the next section.

The network reference model for ITS is depicted in Figure 3.1-3, and is a generic abstraction which builds upon several reference models developed for standard commercial systems. Boxes represent the various physical equipment (with descriptive uppercase letters) that perform the communication functions. The interfaces that are important to ITS are identified by lowercase letters (*s*, *v*, *u*<sub>1</sub>, *u*<sub>2</sub>, *u*<sub>3</sub>).

- *s* signifies a plug-in, smart card interface.
- *v* signifies any kind of wireline connection (for instance, RS-232) or even a bus if the UT and WT are integrated.

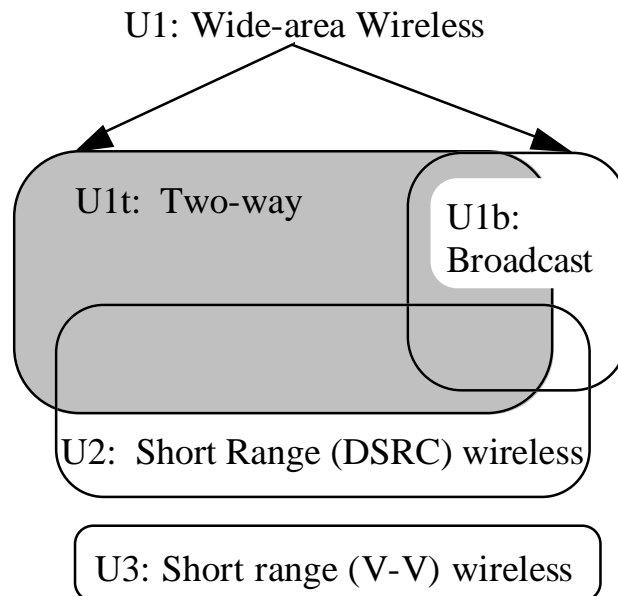
The most important reference point is the wireless interface (*u*) connecting the WBS and the wireless transceiver. To meet the objectives of the national ITS Architecture it will be necessary in some cases for the air interface to be standard. The wireless portion (*u*) of the architecture is manifested in three different ways: *u*<sub>1</sub>, *u*<sub>2</sub>, *u*<sub>3</sub>. Each interface corresponds to one of the wireless manifestations as follows:

- *u*<sub>1</sub> defines the wide area wireless airlink with one of a set of base stations providing connections to mobile or untethered users. It is typified by the current cellular telephone and data networks or the larger cells of Specialized Mobile Radio for two way communication, as well as paging and broadcast systems for one way communication.
- *u*<sub>2</sub> defines the short-range airlink used for close-proximity (typically less than 50–100 feet) transmissions between a mobile user and a base station, typified by transfers of vehicle identification numbers at toll booths.
- *u*<sub>3</sub> addresses the vehicle-vehicle (AHS-type) airlink, for high data rate, burst, usually line-of-sight transmission with high reliability between vehicles where standards are in their infancy. Note that the wide area wireless (U1) interface encompasses both two-way (U1t) and broadcast (U1b) as shown in Figure 3.1-4.
- *b*, *c*, *d*, and *e* correspond to well-established wireline interfaces as documented in Section 7.5.2.



**Figure 3.1.-3 Network Reference Model for the Communications Layer**

The National ITS architecture provides for implementation flexibility. Various of the data flows in the Architecture can be carried over a multiple of these interfaces, and the final choices would be made by the local implementors. This flexibility is depicted conceptually in Figure 3.1.-4.



**Figure 3.1-4 Implementation Flexibility of ITS Architecture Data Flows**

Since the wireline segment encompasses standard wireline configurations, the ITS-critical elements from a standards perspective are those comprising the wireless portion on the left side of Figure 3.1-3. The wireless portion consists of the User Profile Module (UPM), the User Terminal (UT), the Wireless Transceiver (WT) and the Wireless Base Station (WBS). The connections through the Dedicated Terminal and various User Terminals are shown in the column of boxes on the right. The equipment in the center is the existing public telecommunications services, so the details are transparent to ITS, which is a major benefit to the ITS community. *All management, operations, expansion, and improvement costs are shared with the wider set of all telecommunications users.*

This is an important point to jurisdictions and agencies who prefer to procure and trench their own network along the right-of-way. Whereas a financial sensitivity analysis may point to a private solution, it frequently does not fully consider the large and sustained Operation, Administration, Management, and Provisioning (OAM&P) fees that the agency will have to pay the telecommunications vendor during the system's life cycle.

Appendix A.4 presents a detailed description of the wireline side of the above network reference model, in addition to a more thorough treatment for required interfaces such as switches, controllers, and terminals. Appendix A.4 also presents the network entities, interfaces, and signaling plane, and includes a discussion on circuit connection and data packet transmission.

## **3.2 Communication Layer Linkage**

This Communication Layer Linkage section further identifies the relationship between the Transportation Layer and Communication Layer definitions. This is accomplished by mapping the communication services to the data flows identified in the Transportation Layer, generating the Architecture Interconnect Diagrams (AIDs), identifying the Architecture Renditions (ARs), mapping the AIDs to the ARs, and finally identifying the Architecture Interconnect Specifications (AISs) based on the technology assessment.

### **3.2.1 Mapping Communication Services to Data Flows**

Mapping of the communication services to the data flows establishes the first link between the transportation layer and the communication layer. This initial link depends on the completion of two technical architecture milestones. First, the message sizes and data transfer requirements are broadly identified. Second, the physical architecture that allocates logical functions (see Logical Architecture Document) to subsystems necessitates a partitioning exercise which defines the data flows that require communication. This mapping is an iterative procedure that is calibrated by feedback from the logical and physical architectures (and in turn the ITS stakeholders) by retracing the steps shown in Figure 3.0-1.

Appendix A.5 details the mapping process. It also depicts the assigned communication service for each data flow with the corresponding rationale.

### **3.2.2 Architecture Interconnect Diagrams**

As denoted in Figure 3.1-1, this section presents the development of the Architecture Interconnect Diagrams (AIDs). These diagrams show the subsystem-to-subsystem communication interfaces of all transportation subsystem entities (defined in the transportation part of the Physical Architecture). The diagrams identify the communication mode and partition, either wireline or one of three types of wireless connection, as well as documenting the rationale for each of these choices when needed for clarification. The diagrams identify the requirements, developed from the physical relationships of the various

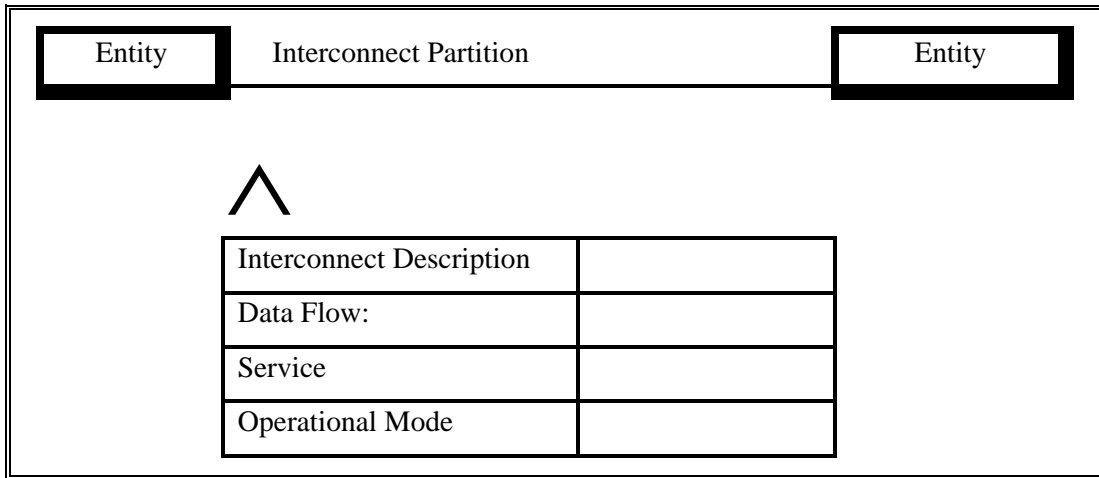
subsystem entities, but do not advocate any specific communication technology to be used. The information contained in the AIDs can be traced to the information provided in the Data Flow-Communications Service Mapping Table (Appendix A.5).

A template is used to illustrate the interconnections between entities and between modules (described in the next sub-section). At this stage in the physical architecture, no AIDs are defined for inter-module information transfer within a simple entity. In fact, from the communication layer perspective, this is not necessary. The most important goal is to identify the inter-entity interconnectivity.

The subsections that follow describe the AID template, and present the Level 1 and Level 0 (top level) AID's.

### **3.2.2.1 AID Template**

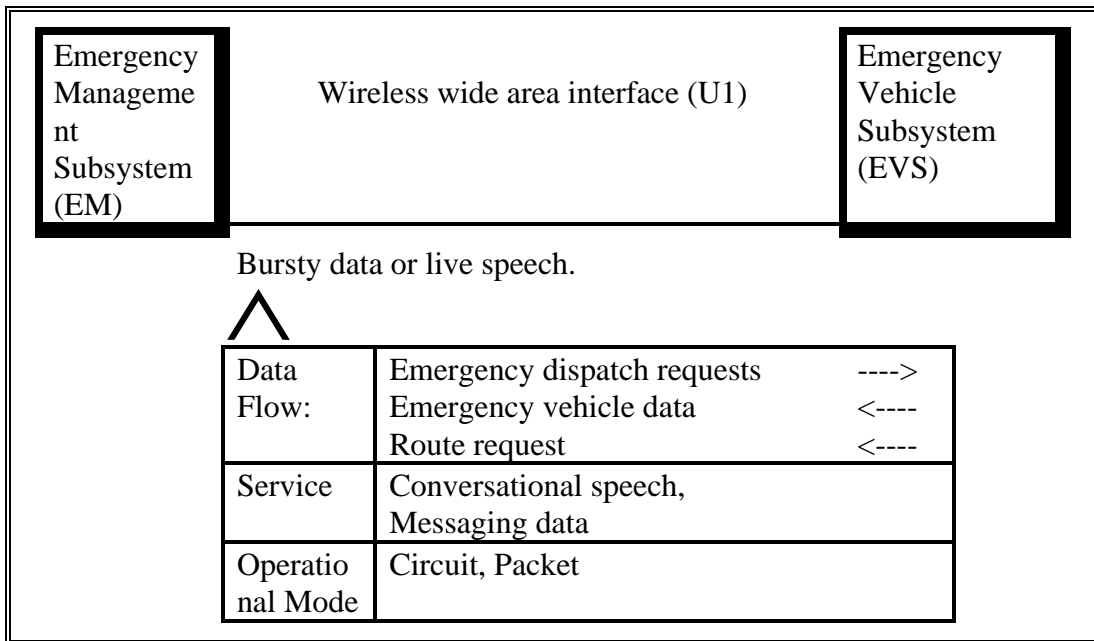
As depicted in Figure 3.2-1, each AID shows the two communicating transportation subsystem entities, the interconnection partition (i.e., wireline, wireless, or both), and a characterization of the interconnection. The latter is not a link-specific description, which the AIS provides, but a high-level interpretation in terms of services and operation modes. When not obvious, the choice of operation mode is based on the rationale provided in Table 3.2-1. The interconnect description for each AID provides a data flow and a service and operation mode description for each data flow between the two entities. The Data Flow information also provides directionality when more than one data flow exists between the entities, not all of which are in the same direction. If all the data flows are in the same direction, no indication is given and the data flows from the left entity to the one on the right.



**Figure 3.2-1. Template for the Architecture Interconnect Diagram (AID)**

**3.2.2.2 Level 1 AIDs**

Using the AID template and Table A.5-1, Data Flow – Communication Services Mapping Table (located in Appendix A of this document), the data flows are represented in an Architecture Interconnect Diagram (AID) format. A single example is presented here in Figure 3.2-2, and various others are compiled in Appendix B.



**Figure 3.2-2 Example of AID Level-1**

### 3.2.2.3 Level 0 AID

Figure 3.2-3, shows the Level 0 Architecture Interconnect Diagram (AID). The level 0 AID is a percolation to a top level of all the detailed, level 1 AID's. It presents the all the interfaces between the physical subsystem entities, capturing the wireline ( $w$ ) or wireless ( $u_1$ ,  $u_2$ , or  $u_3$ ) nature of the interfaces in the ITS architecture. As such, it is a comprehensive, albeit not complete, representation of the ITS communication architecture. More detailed variations can be easily derived from it. For example, Figure 3.2-4 shows the data flows using the u1b wide area wireless broadcast "sub-interface". Figure 3.2-5 shows the subset that uses either of u1t (two-way wide area wireless) or u1b (wide area wireless broadcast). Note that u1b does not imply a certain technology. FM subcarrier, paging, and messaging data networks are possible implementations and they all tend to use a broadcast protocol in the forward, i.e.; fixed to mobile, direction.



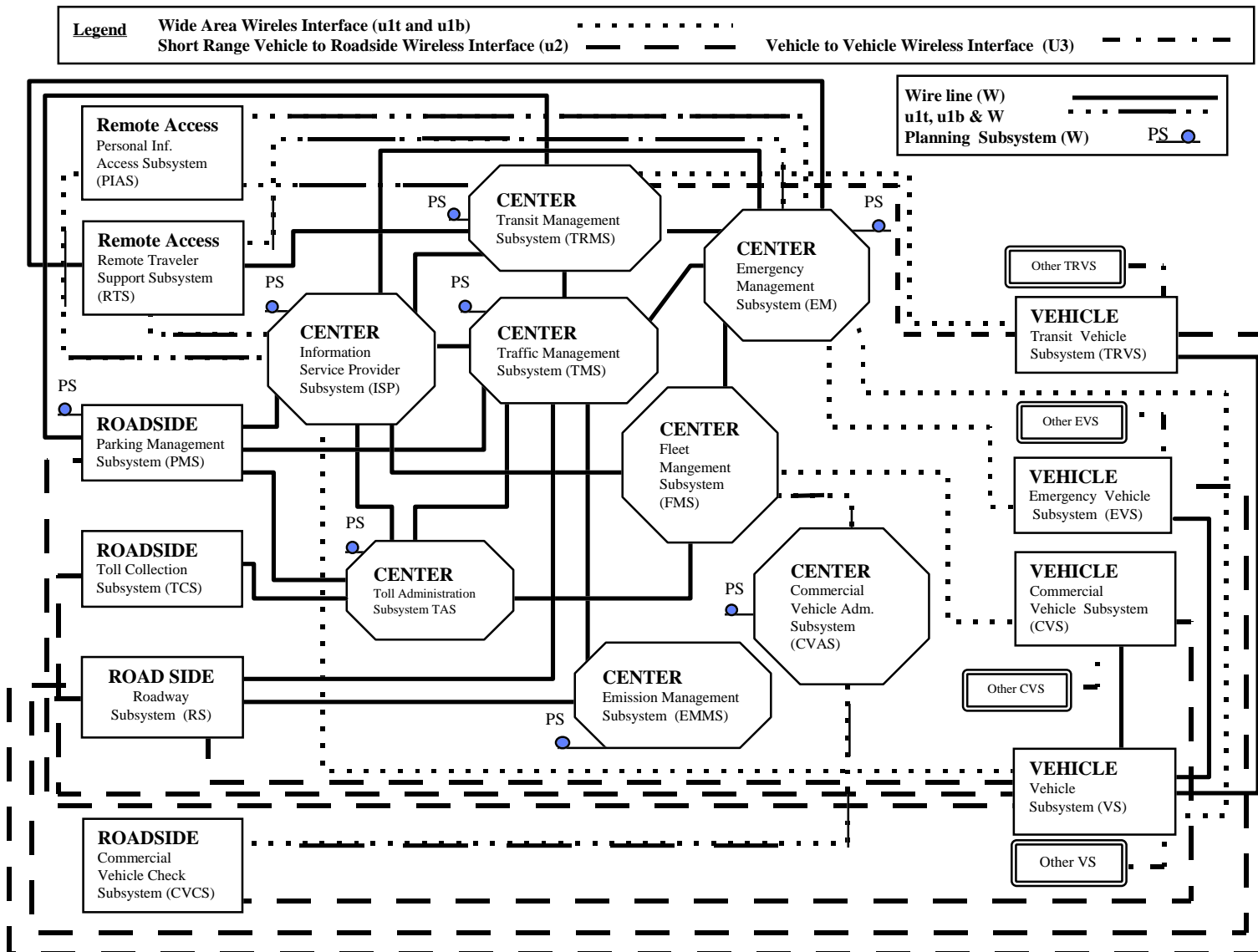
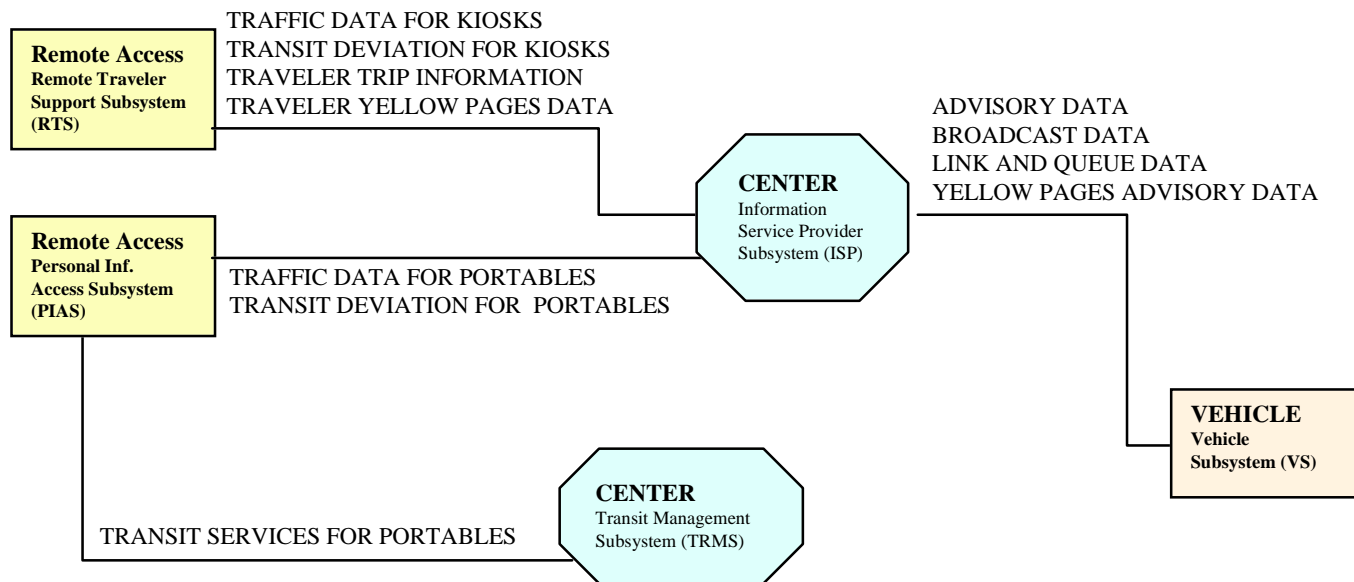
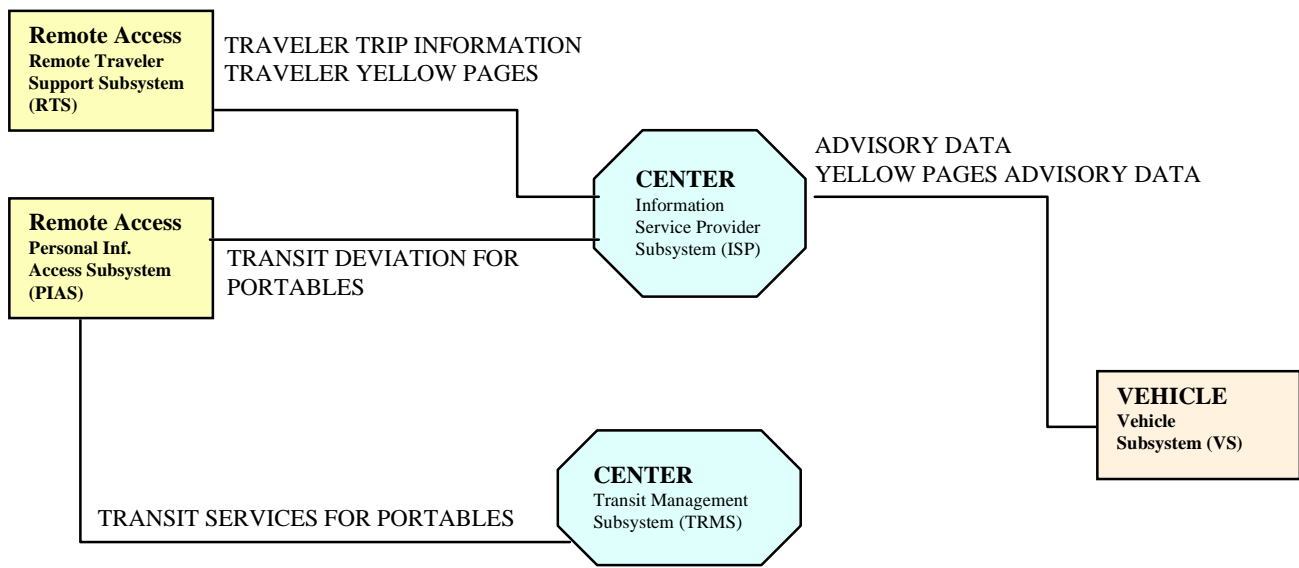


Figure 3.2-3 Level 0 Architecture Interconnect Diagram for the National ITS Architecture



**Figure 3.2-4 Level 0 Architecture Interconnect Diagram for the National ITS Architecture**

**(Subset showing U1b data flows)**



**Figure 3.2-5 Level 0 Architecture Interconnect Diagram for the National ITS Architecture;**  
**(Subset showing data flows using either U1t or U1b)**

### 3.2.3 Architecture Renditions

The next step in the communications architecture design process is the development of the communication Architecture Renditions, as depicted in Figure 3.0-1. Combining elements from the Generic Heirarchical Communication Model (Figure 3.1-1) and the ITS Communication Network Reference Model (Figure 3.1-3) provides a more detailed view of the flow of information between two users. This information includes communication services and operational modes (i.e., circuit switched, packet switched, etc.). The architecture renditions are essentially examples of how to provide connections between users based on the communications network reference model and the evaluations of classes of feasible implementations.

Two levels of renditions are generated. A Level 1 rendition is generated for each of the possible interconnections between services. The Level 0 Rendition (the top level) shows the full connectivity between users over multiple links. The details of the renditions, how they are generated, and those that apply to the different interconnections in the architecture are provided in Appendix C. An example of a Level-1 rendition and the Level-0 will be provided here to support the subsequent task of AIS generation.

#### 3.2.3.1 Level 1 Rendition

Figure 3.2-6 depicts Level 1 renditions for the two-way wide-area wireless communication link ( $u_1$ ) through switched networks. This figure depicts interconnection between tetherless users or tetherless and stationary users, utilizing two distinct classes of two-way wide-area wireless technologies. Several technologies or systems can fit within each rendition. For example, CDPD, RAM, ARDIS and so on are possibilities for implementing the packet-switched wireless data network rendition (shown on the right-hand-side of the diagram in Figure 3.2-6).

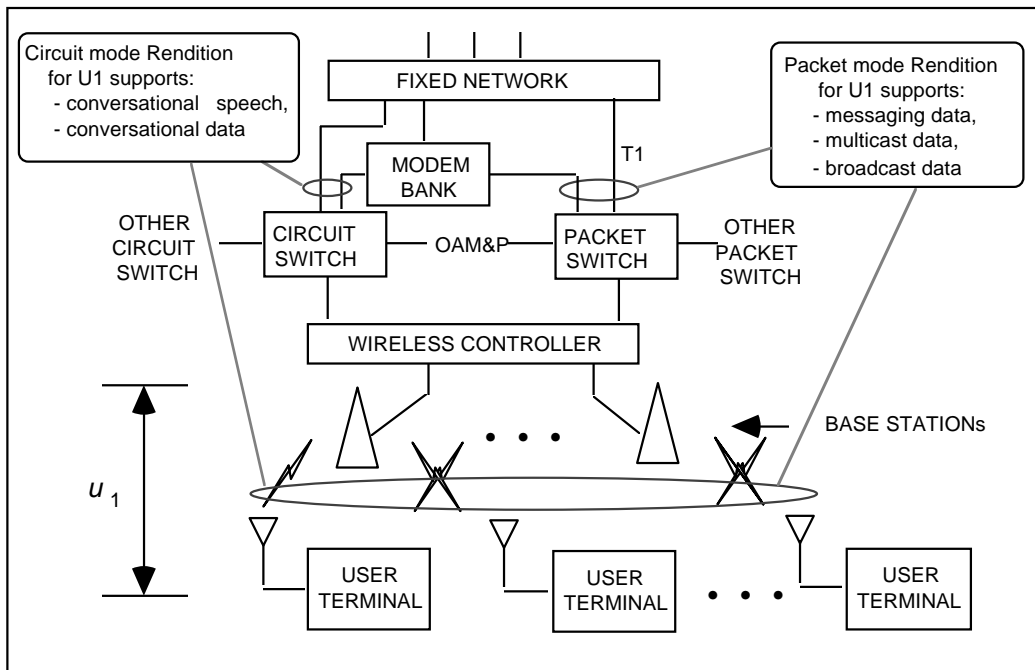
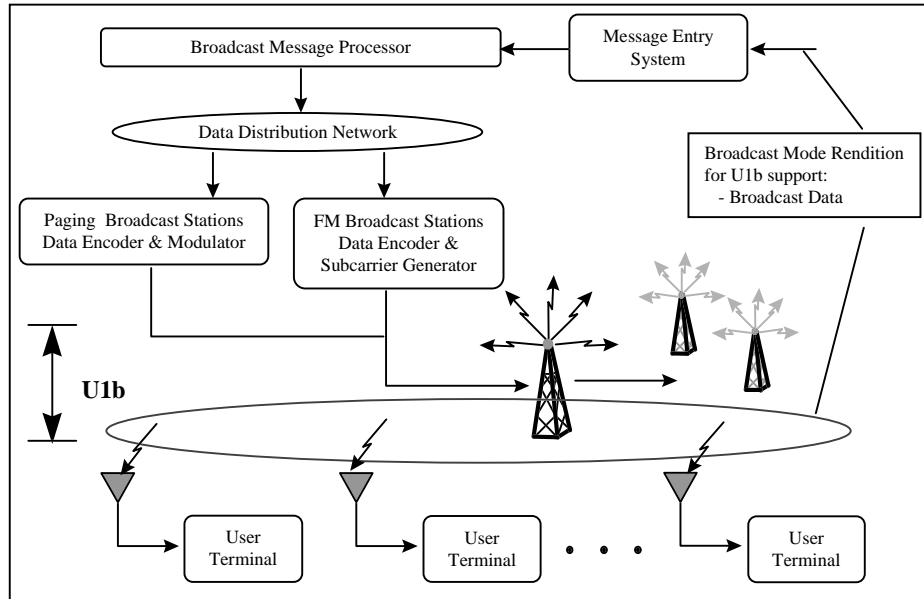


Figure 3.2-6 Rendition 1 — Wide-Area Wireless ( $u_1$ ) Link Through Switched Networks

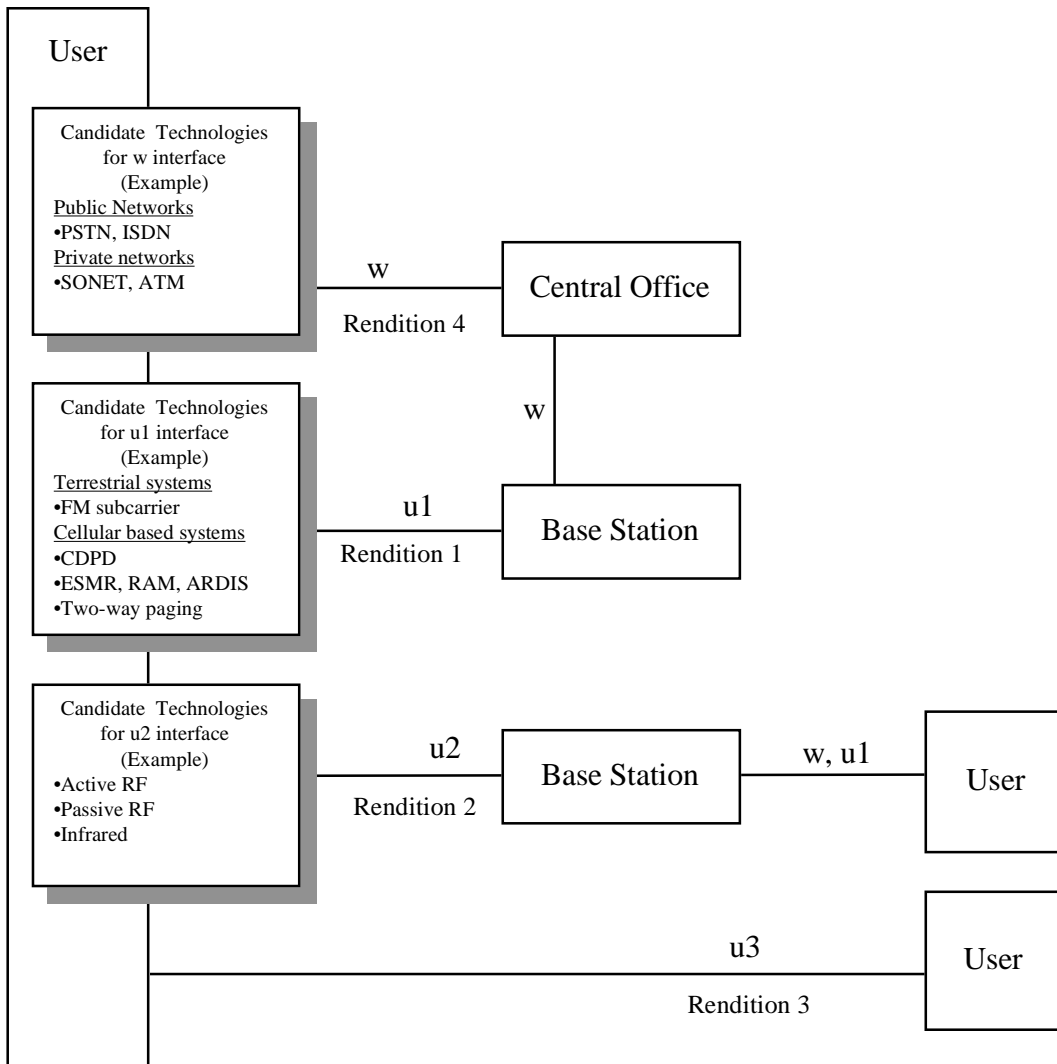
Figure 3.2-7 depicts the rendition for wide area one way wireless link  $u_{1b}$ . It uses broadcast systems which include paging and FM subcarrier technologies for transmitting data to subscribers over the paging and FM frequency channels, respectively.



**Figure 3.2-7 Rendition 1 for Wide-Area One-Way Wireless ( $u_{1b}$ ) Links**

### 3.2.3.2 Level 0 Rendition

Figure 3.2-8 illustrates the Level 0 rendition. It represents a composition of all the renditions to reflect the combined needs of the architecture. This rendition shows a user communicating to another user, central office or a base station over various communication links such as  $u_1$ ,  $u_2$ ,  $u_3$  and  $w$ . Again, the details of this mapping are provided in Appendix C.1.1.



**Figure 3.2-8 Level 0 Rendition**

### 3.2.4 Architecture Interconnect Specifications

The Architecture Interconnect Specifications (AISs) are now developed from the technology assessment and refined by combining the renditions with applicable technologies and evaluating the achievable performance (Figure 3.0-1). This involves mapping the applicable communication technologies to the renditions.

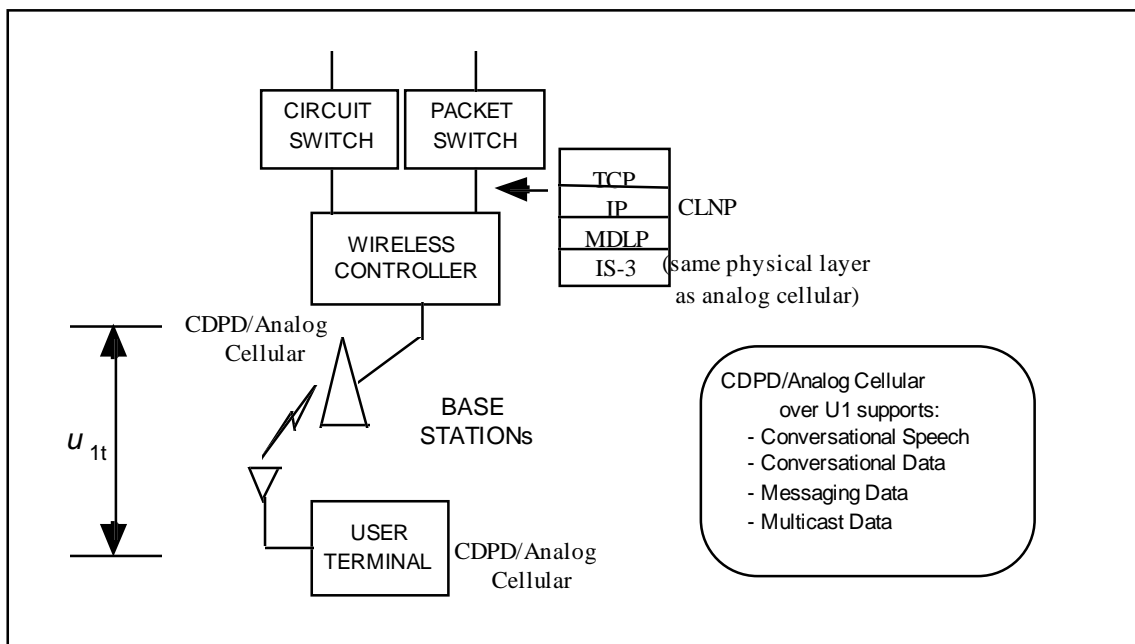
To facilitate the mapping of the communication technologies to the renditions, the candidate wireless and wireline technologies are surveyed. The candidate technologies are further assessed and their performance is evaluated from the National ITS Architecture standpoint. For example, the assessment includes: short range and wide area, one-way and two-way wireless data communication. Systems analyzed include terrestrial networks (e.g., cellular, ESMR), FM broadcast, and satellite systems for mobile and fixed services. The details of this survey, as well as the sources of information, are presented in Appendix D; the assessment results are summarized in Chapter 7.

The results of this assessment are used in identifying the candidate technologies to support level 0 and level 1 renditions. The results of this mapping are summarized below.

It is apparent from the matrices provided in the Technology Assessment Section (Section 7.5) that for the foreseeable future, wireless data networks (such as CDPD, RAM, etc.) form the class of communication systems most suitable to interactive wide area wireless ITS links ( $u_{1t}$ ). The infrastructure is already largely available (short, in some areas, of adding the appliqué equipment). Service costs are already low, and equipment costs are coming down. Coverage nationally is excellent with the possible shortcoming that it may not be available for some time in rural and remote areas. Yet, with the advent of innovative solutions like circuit-switched CDPD – which utilizes the AMPS cellular infrastructure in a manner transparent to a CDPD subscriber – this problem would be largely mitigated. In any event, for ITS users who insist on uninterrupted coverage in remote areas, holes in the coverage of terrestrial cell-based systems can be supplemented by satellite communication systems.

Figure 3.2-9 depicts the use of CDPD in a  $u_{1t}$  communication architecture rendition to create an example of Architecture Interconnect Specification.

According to internal market research and analysis, users are concerned with two overshadowing factors: cost and quality. The Architecture Development Team believes that the market will determine the winning technologies which will gain wide scale acceptance.



**Figure 3.2-9 AIS Example Using CDPD for Wide Area Wireless ( $u_{1t}$ )**

Table 3.2-1 provides an illustration of candidate technologies for the different wireless data flows within the context of the communication layer of the ITS Architecture. In addition to wireless data networks, for wide area ITS data flows, the short range wireless interface  $u_2$  comprises a distinct set of communication services and supporting radio technologies. In a real world ITS implementation, the system designer makes use of the technology assessments of Chapter 7, and the ITS architecture communication renditions presented above, to select the specific communication systems/technologies most appropriate for the deployment at hand.

**Table 3.2-1 Examples of Candidate Technologies for Wireless Data Flows**

<b>u1t - Packet switched wireless data (e.g., CDPD, RAM, ARDIS) for wide-area wireless interface (messaging services; bursty data transfers)</b>		
<b>Source</b>	<b>Architecture Flow</b>	<b>Destination</b>
CVAS	Electronic credentials	FMS
CVAS	Safety information	CVCS
CVS	Driver & vehicle information	FMS
CVS	On board vehicle data	FMS
EM	emergency dispatch requests	EVS
EM	emergency acknowledge	VS
EM	emergency acknowledge	RTS
EM	emergency acknowledge	PIAS
EVS	Emergency vehicle driver status update	EM
EVS	Emergency vehicle driver input	EM
EVS	Emergency vehicle dispatch acknowledge	EM
FMS	fleet to driver update	CVS
PIAS	Demand responsive transit request	TRMS
PIAS	Traveler information request	ISP
PIAS	Emergency notification	EM
RTS	Emergency notification	EM
TRMS	Demand responsive transit request	PIAS
TRMS	Request for vehicle measures	TRVS
TRMS	Route assignment	TRVS
TRVS	Emergency notification	TRMS
TRVS	Vehicle probe data	TRMS
TRVS	Traveler information request	TRMS
VS	vehicle probe data	ISP
VS	emergency notification	EM
VS	Traveler information request	ISP
VS	map update request	X23

<b>u1t - Circuit switched wireless data (e.g., Cellular, ESMR) (Messaging; larger data transactions, e.g., compressed image)</b>		
<b>Source</b>	<b>Architecture Flow</b>	<b>Destination</b>
ISP	Traveler information	PIAS
ISP	Traveler information	VS
X23 MAP Update Provider	Map updates	PIAS
X23 MAP Update Provider	Map updates	VS



**u1t - Circuit Switched Voice (e.g., Cellular, SMR)  
(live voice interaction; early implementations)**

Source	Architecture Flow	Destination
EM	Assigned route	EVS
EM	Hazmat information	EVS
EM	Emergency dispatch requests	EVS
EM	Emergency status	RTS
EVS	Emergency vehicle dispatch acknowledge	EM
EVS	Emergency vehicle driver input	EM
RTS	Emergency notification	EM
VS	Emergency notification	EM

**u1b - Broadcast (subcarrier or paging-type) services  
(Broadcast of free services and services that require subscription;  
e.g., traveler information,)**

source	Architecture Flow	destination
ISP	Broadcast information	PIAS
ISP	traveler information	VS
ISP	broadcast information	VS
ISP	broadcast information	RTS

**u1t - Packet switched wireless data multicast Services (Distribution  
services that require subscription; e.g., map updates)**

source	Architecture Flow	destination
ISP	traveler information	PIAS
ISP	traveler information	VS
ISP	broadcast information	VS
ISP	broadcast information	RTS
X23 MAP update provider	map updates	PIAS
X23 MAP update provider	map updates	VS

**u2 - beacon for close-proximity wireless communication between  
vehicle and roadside**

Source	Architecture Flow	Destination
CVS	Border crossing ID	CVCS
CVS	on board safety data	CVCS
CVCS	safety inspection record	CVS
CVCS	Pull in message	CVS
EVS	Emergency vehicle preemption request	RS
PMS	Tag update	VS
RS	AHS control data	VS
RS	roadway signage data	VS
RS	intersection status	VS
TCS	Request tag data	VS
TRVS	signal priority request	RS
VS	Tag data	TCS
VS	AHS vehicle data	RS
VS	Tag data	PMS

## 4. SCENARIOS AND TIME FRAMES

Three scenario regions will be studied (Urbansville, Thruville, and Mountainville), for three time frames (1997, 2002, and 2012). These nine total scenarios were modeled through the use of government-supplied information, along with statistical data and assumptions related to the evaluatory design that is a subset of the National ITS Architecture definition effort.

The goal of this part of the modeling task is to determine the number of users of each of the user service groupings defined for the data loading analysis task. In most cases, this is the number of vehicles because most of the messages are handled per vehicle. The exception is the traveler information user (PIAS user) service group where no user vehicle is involved.

Because communications systems must be designed for the peak load, the important number of users to be derived is that for the peak period. The off-peak period number will be defined as a fraction of the peak period number.

### 4.1 Evaluatory Design

The evaluatory design is a candidate ITS deployment with a set of assumptions for the number of users and vehicles, and the number of centers, sensors, etc. The important assumptions in the wireless data loading are the number of vehicles and users for each of the user service groups. The total set of assumptions for the evaluatory design are contained in the Evaluatory Design Document.

### 4.2 Baseline Information for the Scenario Regions

The information supplied by the Government on the nine scenario regions and time frames includes the regional population and number of household vehicles. This information was used along with national statistical data to derive the number of vehicles or users that are potential users of ITS services by user service category within each scenario. Table 4.2-1 lists the supplied population and vehicle data.

**Table 4.2-1 Supplied Population and Household Vehicle Data**

<b>Region</b>	<b>Time Frame</b>	<b>Population</b>	<b>Household Vehicles</b>
<b>Urbansville</b>	<b>1997</b>	2814950	1688970
<b>Urbansville</b>	<b>2002</b>	3106674	1842105
<b>Urbansville</b>	<b>2012</b>	3788627	2273176
<b>Thruville</b>	<b>1997</b>	1005185	851272
<b>Thruville</b>	<b>2002</b>	1055445	893836
<b>Thruville</b>	<b>2012</b>	1166015	987476
<b>Mountainville</b>	<b>1997</b>	17480	6735
<b>Mountainville</b>	<b>2002</b>	17920	6904
<b>Mountainville</b>	<b>2012</b>	18845	7260

### 4.3 Number of Potential Users by User Service Group

In order to enhance the understanding of the data loads generated by ITS services, the analyses were performed for seven distinct user service groups, each with its own population, message set, peak period definition, and message frequency of use. The user service groups include private vehicles, CVO-Local vehicles, CVO-long haul vehicles, travelers (PIAS users), transit management, emergency management, and probes.

The number of potential users that might buy a service was determined for each of the nine scenarios through the use of national statistics. The methods used are shown in detail in Appendix E. The numbers are the same as those found in the Evaluatory Design Document.

**The lack of a particular service (e.g., fixed route transit in the rural scenario) was handled later in the data loading models with the lack of an entry in the database table of market packages of services for that scenario, preventing messages related to that service from being included in the message set for that scenario.** This process is defined in Section 5.3, as it defines the available message set for that scenario.

In the case of the Thruville scenario, the added traffic traveling completely through the entire scenario region must be added to the model. This was modeled by increasing the number of private vehicles and CVO long haul vehicles that would be expected from the resident population (as derived from national statistics) by one-third. The other user service groups do not travel beyond the scenario region by definition.

The number of potential users was derived for the peak period defined for that particular user service group. The number of potential users for the off-peak period was then defined as a fraction of the peak period number.

## Number of Potential Users Summary

Table 4.3-1 shows the summary of the number of potential users for each of the nine scenarios. These are the same values as in the Evaluatory Design Document.

**Table 4.3-1 Number of Potential Vehicles or Users for Each of the Seven User Service Groups and Each of the Nine Scenarios.**

	Pr. Veh.	CVO-LH	CVO-Lo.	Trav.	Transit	Emerg.	Probes
<b>Urbans. 1997</b>	760037	5797	81155	200750	1661	4444	7704
<b>Urbans. 2002</b>	828947	6397	89565	262920	1833	4850	7704
<b>Urbans. 2012</b>	1022929	7802	109226	432310	2235	5981	7704
<b>Thru. 1997</b>	383072	2753	28979	99610	593	2128	3900
<b>Thru. 2002</b>	402226	2891	30428	125500	623	2319	3900
<b>Thru. 2012</b>	444364	3194	33616	184870	688	2562	3900
<b>Mount. 1997</b>	3031	36	504	830	0	7	800
<b>Mount. 2002</b>	3107	37	517	1010	11	7	800
<b>Mount. 2012</b>	3267	39	543	1420	11	8	800

## 4.4 Penetrations

A penetration factor was applied to each of the potential number of users figures to arrive at the actual number of users. The penetrations were applied by market package for the 1997, 2002, and 2012 time frames. These penetrations are from the Evaluatory Design Document, using the “high” penetration estimate for the equipment package most appropriate for that market package. The penetration factors for market packages by time frame are shown in Table 4.4-1. Each of the seven user service groups was allowed access to any of the market packages that were of use to them. The penetration is applied to the frequency of use value that is assigned later to each message for each user service group to account for the variations in the amount of usage that might occur in the user service groups. The result is that the messages each have a penetration value associated with them. There is not simply a single penetration value for an entire user service group.

**Table 4.4-1 Penetration Factor by Market Package and Time Frame**

<b>Market Package Name</b>	<b>1997</b>	<b>2002</b>	<b>2012</b>	
Transit Vehicle Tracking		0.33	1	1
Transit Fixed-Route Operations		0.66	1	1
Demand Response Transit Operations		0.66	1	1
Transit Passenger and Fare Management		0.66	1	1
Transit Security		0.33	1	1
Transit Maintenance		0.66	1	1
Multi-modal Coordination		0.66	1	1
Broadcast Traveler Information		0.03	0.1	0.5
Interactive Traveler Information		0.01	0.1	0.2
Autonomous Route Guidance		0.01	0.1	0.2
Dynamic Route Guidance		0.01	0.1	0.2
ISP Based Route Guidance		0.01	0.1	0.2
Integrated Transportation Management/Route Guidance		0.01	0.1	0.2
Yellow Pages and Reservation		0.01	0.1	0.2
Dynamic Ridesharing		0.01	0.1	0.2
In Vehicle Signing		0	0.01	0.05
Network Surveillance		0.004	0.02	0.05
Probe Surveillance		0.004	0.02	0.05
Surface Street Control		0.2	0.5	0.9
Freeway Control		0.75	1	1
HOV and Reversible Lane Management		0.07	0.2	0.4
Traffic Information Dissemination		1	1	1
Regional Traffic Control		0	0	1
Incident Management System		1	1	1
Traffic Network Performance Evaluation		0.5	1	1
Dynamic Toll/Parking Fee Management		0.5	0.75	1
Emissions and Environmental Hazards Sensing		1	1	1
Virtual TMC and Smart Probe Data		0.004	0.02	0.05
Vehicle Safety Monitoring		0.02	0.2	0.5
Driver Safety Monitoring		0	0.05	0.25
Longitudinal Safety Warning		0	0.02	0.15
Lateral Safety Warning		0	0.05	0.15
Intersection Safety Warning		0	0.001	0.02
Pre-Crash Restraint Deployment		0	0	0.05
Driver Visibility Improvement		0	0	0.05
Advanced Vehicle Longitudinal Control		0	0.02	0.15
Advanced Vehicle Lateral Control		0	0	0.05
Intersection Collision Avoidance		0	0	0.02
Automated Highway System		0	0	0.01
Fleet Administration		0.25	0.5	0.8
Freight Administration		0.05	0.1	0.5
Electronic Clearance		0.25	0.5	0.85
CV Administrative Processes		0.25	0.5	0.85
International Border Electronic Clearance		0.25	0.5	0.85
Weigh-In-Motion		1	1	1
Roadside CVO Safety		1	1	1
On-board CVO Safety		0	0.02	0.1
CVO Fleet Maintenance		0.05	0.1	0.5
HAZMAT Management		0.05	0.1	0.5
Emergency Response		0.5	1	1
Emergency Routing		0.5	1	1
Mayday Support		0.5	1	1
ITS Planning		0	1	1

#### 4.5 Assignment of Users to Communications Interfaces

Messages are assigned to flow over any appropriate communications media, and individual messages are allowed to flow over multiple media. The u1t interface is the wide area two-way wireless interface, and the u1b interface is the wide area broadcast interface. The u<sub>2</sub> interface is the short range vehicle-to-roadside wireless interface. The w interface is the wireline interface.

Messages shared between the u1t and u1b interfaces include traffic advisories and data, and transit deviations and services. In order to study the worst case, it was assumed in the data loading analysis that the broadcast transmission does not reduce the use of u1t data traffic. Therefore, the u1t fraction may be shown as 1 in cases where a message is assigned to other interfaces as well.

Messages shared between the u1t and u<sub>2</sub> interfaces include transit management and services, and parking advance payment. In order to study the worst case, it was assumed in the data loading analysis that the u<sub>2</sub> transmissions do not reduce the use of u1t data traffic.

For the case of messages shared between the u1t and w interfaces, it was assumed that 50% of the traveler user service group (PIAS users) use the w interface and 50% use the u1t interface. It was also assumed that 90% of the kiosks are connected over the w interface, and 10% use the u1t interface. In addition, 90% of the commercial vehicle check subsystems and fleet management subsystems use a wireline interface, and 10% use the u1t interface, because they are not at fixed locations. In the case of very large messages, it was decided not to include them on all applicable interfaces. For example, messages (flows) for map updates, including the associated requests and payment responses were not included on the u1t interface because their large size would make it unlikely that any user would choose that means of update. A wireline connection, such as during an evening, or substitution of an updated CD are the assumed map update mechanisms. Another example is “link\_and\_queue\_data”, which, because of its size, is assigned to the u1b interface.

Map and link + queue data updates of a more limited geographic extent, or incremental updates, when included in future versions of the logical architecture would make sense for the u1t interface.

The message “vehicle\_guidance\_probe\_data” from VS to ISP appears in its own user service group, probes. Finally, it was assumed that display and map updates, because of their very large size (and therefore transmission cost) would not be used by any of the above users unless connected at that moment by wireline access. They would simply choose to perform updates while connected over a w interface or use another transfer media such as a CD.

The message assignments to interfaces are shown in Table 4.5-1. They are sorted by physical architecture source and sink. An “x” is placed in the interfaces over which a particular message is allowed to flow in this analysis. The column labeled “u1t Fraction” indicates the fraction of that message’s data that is assigned to the u1t interface. The balance is assigned to the other interface(s). In a few cases, the u1t Fraction value was reduced on some individual messages relative to others for that user type to include a factor to account for the lower usage of a particular user service feature because, for instance, it is less suitable for use from a mobile location (e.g., ISP to VS message advisory\_data, which is large and will be costly to transmit on the u1t interface, is assigned a fraction of 0.5 instead of 1).

**Table 4.5-1 Communications Interfaces Assigned to Each of the Messages**

**Note: Data flows to terminators are all wireline (w).**

PA Source	PA Sink	Message Data Flow	u1t	u1t Fraction	u1b	u <sub>2</sub>	u <sub>3</sub>	w
CVAS	CVCS	cv_credentials_database_update	x	0.1				x
CVAS	CVCS	cv_credentials_information_response	x	0.1				x
CVAS	CVCS	cv_safety_database_update	x	0.1				x
CVAS	CVCS	cv_safety_information_response	x	0.1				x
CVAS	FMS	cf_clearance_enrollment_confirm	x	0.1				x
CVAS	FMS	cf_enrollment_information	x	0.1				x
CVAS	FMS	cf_enrollment_payment_confirmation	x	0.1				x
CVAS	FMS	cv_enrollment_information	x	0.1				x
CVAS	FMS	cv_enrollment_payment_confirmation	x	0.1				x
CVAS	PS	cv_operational_data						x
CVCS	CVAS	cv_credentials_information_request	x	0.1				x
CVCS	CVAS	cv_roadside_daily_log	x	0.1				x
CVCS	CVAS	cv_safety_information_request	x	0.1				x
CVCS	CVAS	cv_update_safety_problems_list	x	0.1				x
CVCS	CVS	cv_inspection_data_output				x		
CVCS	CVS	cv_on_board_pull_in_output				x		
CVCS	CVS	cv_on_board_screening_record				x		
CVCS	CVS	cv_request_electronic_clearance_data				x		
CVCS	CVS	cv_request_on_board_data				x		
CVS	CVCS	cv_electronic_clearance_data				x		
CVS	CVCS	cv_on_board_data				x		
CVS	FMS	cf_driver_route_instructions_request	x	1				
CVS	FMS	cf_on_board_vehicle_data	x	1				
CVS	FMS	cv_driver_enrollment_payment_request	x	1				
CVS	FMS	cv_driver_enrollment_request	x	1				
CVS	FMS	cv_driver_route_request	x	1				
CVS	FMS	cv_driver_storage_request	x	1				
CVS	FMS	cv_static_route_data	x	1				
EM	EVS	emergency_vehicle_driver_outputs	x	1				
EM	FMS	cf_hazmat_request	x	0.1				x
EM	ISP	emergency_vehicle_route_request						x
EM	ISP	incident_information						x
EM	PIAS	emergency_request_personal_traveler_acknowledge	x	0.5				x
EM	PS	emergency_vehicle_operational_data						x
EM	RTS	emergency_request_kiosk_traveler_acknowledge						x
EM	TMS	emergency_vehicle_green_wave						x
EM	TMS	incident_details						x
EM	TMS	incident_response_status						x
EM	TRMS	transit_incident_coordination_data						x
EM	VS	emergency_request_driver_acknowledge	x	1				
EM	VS	emergency_request_vehicle_acknowledge	x	1				
EMMS	PS	pollution_operational_data						x
EMMS	RS	pollution_state_vehicle_acceptance_criteria						x
EMMS	TMS	pollution_incident						x
EMMS	TMS	pollution_state_data						x
EMMS	TMS	wide_area_pollution_data						x
EVS	EM	emergency_driver_dispatch_acknowledge	x	1				
EVS	EM	emergency_driver_status_update	x	1				

**Table 4.5-1 Communications Interfaces Assigned to Each of the Messages**

**Note: Data flows to terminators are all wireline (w).**

PA Source	PA Sink	Message Data Flow	u1t	u1t Fraction	u1b	u <sub>2</sub>	u <sub>3</sub>	w
EVS	EM	emergency_vehicle_driver_inputs	x	1				
EVS	RS	emergency_vehicle_preemptions				x		
FMS	CVAS	cf_enroll_clearance_data	x	0.1				x
FMS	CVAS	cf_enrollment_payment_request	x	0.1				x
FMS	CVAS	cf_enrollment_request	x	0.1				x
FMS	CVAS	cv_enrollment_payment_request	x	0.1				x
FMS	CVAS	cv_enrollment_request	x	0.1				x
FMS	CVS	cf_driver_route_instructions	x	1				
FMS	CVS	cf_request_on_board_vehicle_data	x	1				
FMS	CVS	cv_driver_enrollment_information	x	1				
FMS	CVS	cv_driver_enrollment_payment_confirmation	x	1				
FMS	CVS	cv_driver_route_data	x	1				
FMS	CVS	cv_static_route_request	x	1				
FMS	EM	cf_hazmat_route_information	x	0.1				x
FMS	EM	cf_hazmat_vehicle_information	x	0.1				x
FMS	ISP	cf_route_request	x	0.1				x
FMS	ISP	cv_route_request	x	0.1				x
ISP	EM	emergency_vehicle_route						x
ISP	EM	incident_information_request						x
ISP	FMS	cf_route	x	0.1				x
ISP	FMS	cv_route	x	0.1				x
ISP	PIAS	traffic_data_for_portables			x			x
ISP	PIAS	transit_deviations_for_portables	x	0.05	x			x
ISP	PIAS	traveler_guidance_route	x	0.05				x
ISP	PIAS	traveler_map_update_payment_response		0.5				x
ISP	PIAS	traveler_personal_display_update_payment_response						x
ISP	PIAS	traveler_personal_payment_confirmation	x	0.5				x
ISP	PIAS	traveler_personal_transaction_confirmation	x	0.5				x
ISP	PIAS	traveler_personal_trip_information	x	0.05				x
ISP	PIAS	traveler_personal_yellow_pages_data	x	0.5				x
ISP	PMS	advanced_other_charges_request						x
ISP	PMS	advanced_traveler_charges_request						x
ISP	PMS	parking_lot_data_request						x
ISP	PMS	parking_lot_reservation_request						x
ISP	PS	current_other_routes_use						x
ISP	PS	current_other_routes_use						x
ISP	PS	current_road_network_use						x
ISP	RTS	advanced_tolls_and_charges_roadside_confirm	x	0.1				x
ISP	RTS	traffic_data_for_kiosks			x			x
ISP	RTS	transit_deviations_for_kiosks			x			x
ISP	RTS	traveler_payment_confirmation	x	0.1				x
ISP	RTS	traveler_transaction_confirmation	x	0.1				x
ISP	RTS	traveler_trip_information	x	0.1	x			x
ISP	RTS	traveler_yellow_pages_data	x	0.1	x			x
ISP	TAS	advanced_other_tolls_request						x
ISP	TAS	advanced_traveler_tolls_request						x
ISP	TMS	commercial_vehicle_incident						x
ISP	TMS	confirm_incident_data_output						x



**Table 4.5-1 Communications Interfaces Assigned to Each of the Messages**

**Note: Data flows to terminators are all wireline (w).**

PA Source	PA Sink	Message Data Flow	u1t	u1t Fraction	u1b	u <sub>2</sub>	u <sub>3</sub>	w
ISP	TMS	current_other_routes_use						x
ISP	TMS	current_road_network_use						x
ISP	TMS	current_transit_routes_use						x
ISP	TMS	low_traffic_route						x
ISP	TMS	media_incident_data_updates						x
ISP	TMS	request_incident_media_data						x
ISP	TMS	traffic_data_media_request						x
ISP	TRMS	advanced_other_fares_request						x
ISP	TRMS	advanced_tolls_and_charges_vehicle_confirm						x
ISP	TRMS	advanced_traveler_fares_request						x
ISP	TRMS	paratransit_service_confirmation						x
ISP	TRMS	paratransit_trip_request						x
ISP	TRMS	request_prices						x
ISP	TRMS	transit_services_advisories_request						x
ISP	TRMS	transit_services_guidance_request						x
ISP	TRMS	transit_vehicle_deviations_details_request						x
ISP	VS	advanced_fares_and_charges_response	x	1				
ISP	VS	advanced_tolls_and_fares_response	x	1				
ISP	VS	advisory_data	x	0.5	x			
ISP	VS	broadcast_data			x			
ISP	VS	link_and_queue_data			x			
ISP	VS	yellow_pages_advisory_data	x	1	x			
PIAS	EM	emergency_request_personal_traveler_details	x	0.5				x
PIAS	ISP	traffic_data_portables_request	x	0.5				x
PIAS	ISP	transit_deviations_portables_request	x	0.5				x
PIAS	ISP	traveler_map_update_payment_request						x
PIAS	ISP	traveler_personal_current_condition_request	x	0.5				x
PIAS	ISP	traveler_personal_display_update_payment_request						x
PIAS	ISP	traveler_personal_payment_information	x	0.5				x
PIAS	ISP	traveler_personal_transaction_request	x	0.5				x
PIAS	ISP	traveler_personal_trip_confirmation	x	0.5				x
PIAS	ISP	traveler_personal_trip_request	x	0.5				x
PIAS	ISP	traveler_personal_yellow_pages_information_request	x	0.5				x
PIAS	ISP	traveler_route_accepted	x	0.5				x
PIAS	ISP	traveler_route_request	x	0.05				x
PIAS	TRMS	transit_services_portables_request	x	0.5				x
PMS	ISP	advanced_other_charges_confirm						x
PMS	ISP	advanced_traveler_charges_confirm						x
PMS	ISP	parking_lot_availability						x
PMS	ISP	parking_lot_reservation_confirm						x
PMS	TMS	parking_lot_charge_change_response						x
PMS	TMS	parking_lot_current_occupancy						x
PMS	TMS	parking_lot_current_state						x
PMS	TMS	vms_parking_guidance_for_highways						x
PMS	TMS	vms_parking_guidance_for_roads						x
PMS	TRMS	parking_lot_price_data						x
PMS	TRMS	parking_lot_transaction_reports						x
PMS	TRMS	parking_lot_transit_request						x

**Table 4.5-1 Communications Interfaces Assigned to Each of the Messages**

**Note: Data flows to terminators are all wireline (w).**

PA Source	PA Sink	Message Data Flow	u1t	u1t Fraction	u1b	u <sub>2</sub>	u <sub>3</sub>	w
PMS	VS	advanced_parking_lot_charges_confirm				x		
PMS	VS	parking_lot_payment_debited				x		
PMS	VS	parking_lot_payment_request				x		
PMS	VS	parking_lot_tag_data_clear				x		
PMS	VS	parking_lot_tag_data_request				x		
PMS	VS	parking_lot_tag_data_update				x		
RS	EMMS	pollution_state_roadside_collection						x
RS	EMMS	pollution_state_vehicle_collection						x
RS	EMMS	pollution_state_vehicle_log_data						x
RS	TMS	ahs_checking_details						x
RS	TMS	hov_lane_data_input						x
RS	TMS	incident_analysis_data						x
RS	TMS	indicator_input_data_from_highways						x
RS	TMS	indicator_input_data_from_roads						x
RS	TMS	roadside_fault_data						x
RS	TMS	traffic_image_data						x
RS	TMS	traffic_sensor_data						x
RS	TMS	vehicle_pollution_alert						x
RS	TMS	vehicle_pollution_message_for_highways						x
RS	TMS	vehicle_pollution_message_for_roads						x
RS	VS	ahs_check_response				x		
RS	VS	vehicle_signage_data				x		
RTS	EM	emergency_request_kiosk_traveler_details	x	0.1				x
RTS	ISP	advanced_tolls_and_charges_roadside_request	x	0.1				x
RTS	ISP	traffic_data_kiosk_request	x	0.1				x
RTS	ISP	transit_deviation_kiosk_request	x	0.1				x
RTS	ISP	traveler_current_condition_request	x	0.1				x
RTS	ISP	traveler_payment_information	x	0.1				x
RTS	ISP	traveler_transaction_request	x	0.1				x
RTS	ISP	traveler_trip_confirmation	x	0.1				x
RTS	ISP	traveler_trip_request	x	0.1				x
RTS	ISP	traveler_yellow_pages_information_request	x	0.1				x
RTS	TRMS	fare_collection_roadside_violation_information						x
RTS	TRMS	other_services_roadside_request						x
RTS	TRMS	request_roadside_fare_payment						x
RTS	TRMS	transit_roadside_fare_payment_confirmation						x
RTS	TRMS	transit_roadside_passenger_data						x
RTS	TRMS	transit_services_kiosk_request						x
RTS	TRMS	transit_services_travelers_request						x
RTS	TRMS	transit_user_roadside_image						x
TAS	ISP	advanced_other_tolls_confirm						x
TAS	ISP	advanced_traveler_tolls_confirm						x
TAS	ISP	probe_data_for_guidance						x
TAS	ISP	vehicle_toll_probe_data						x
TAS	PS	toll_operational_data						x
TAS	TCS	advanced_toll_needed						x
TAS	TCS	toll_bad_payment_check_response						x
TAS	TMS	probe_data_for_traffic						x

**Table 4.5-1 Communications Interfaces Assigned to Each of the Messages**

**Note: Data flows to terminators are all wireline (w).**

PA Source	PA Sink	Message Data Flow	u1t	u1t Fraction	u1b	u <sub>2</sub>	u <sub>3</sub>	w
TAS	TMS	toll_price_changes_response						x
TAS	TRMS	toll_price_data						x
TAS	TRMS	toll_transaction_reports						x
TCS	TAS	advanced_toll_transactions						x
TCS	TAS	confirm_advanced_tolls_payment						x
TCS	TAS	current_toll_transactions						x
TCS	TAS	toll_bad_payment_check_request						x
TCS	TAS	toll_payment_violator_data						x
TCS	TAS	toll_violation_information						x
TCS	VS	toll_payment_debited				x		
TCS	VS	toll_payment_request				x		
TCS	VS	toll_tag_data_clear				x		
TCS	VS	toll_tag_data_request				x		
TCS	VS	toll_tag_data_update				x		
TMS	EM	incident_alert						x
TMS	EM	incident_details_request						x
TMS	EM	incident_response_clear						x
TMS	EMMS	pollution_state_data_request						x
TMS	ISP	current_highway_network_state						x
TMS	ISP	current_road_network_state						x
TMS	ISP	incident_data_output						x
TMS	ISP	link_data_for_guidance						x
TMS	ISP	predicted_incidents						x
TMS	ISP	prediction_data						x
TMS	ISP	retrieved_incident_media_data						x
TMS	ISP	traffic_data_for_media						x
TMS	ISP	traffic_data_media_parameters						x
TMS	PMS	parking_lot_charge_change_request						x
TMS	PMS	parking_lot_input_data						x
TMS	PMS	selected_parking_lot_control_strategy						x
TMS	PMS	static_data_for_parking_lots						x
TMS	PS	ahs_operational_data						x
TMS	PS	current_incident_static_data						x
TMS	PS	current_traffic_static_data						x
TMS	PS	traffic_data_for_deployment						x
TMS	RS	ahs_control_data_changes						x
TMS	RS	indicator_control_data_for_highways						x
TMS	RS	indicator_control_data_for_roads						x
TMS	RS	indicator_control_monitoring_data_for_highways						x
TMS	RS	indicator_control_monitoring_data_for_roads						x
TMS	RS	vehicle_sign_data						x
TMS	TAS	toll_price_changes_request						x
TMS	TRMS	parking_lot_charge_request						x
TMS	TRMS	prediction_data						x
TMS	TRMS	toll_price_request						x
TMS	TRMS	transit_conditions_demand_request						x
TMS	TRMS	transit_fare_request						x
TMS	TRMS	transit_services_changes_request						x

**Table 4.5-1 Communications Interfaces Assigned to Each of the Messages**

**Note: Data flows to terminators are all wireline (w).**

PA Source	PA Sink	Message Data Flow	u1t	u1t Fraction	u1b	u2	u3	w
TMS	TRMS	transit_services_demand_request						x
TRMS	EM	transit_coordination_data						x
TRMS	EM	transit_emergency_data						x
TRMS	EM	transit_incident_details						x
TRMS	ISP	advanced_other_fares_confirm						x
TRMS	ISP	advanced_tolls_and_charges_vehicle_request						x
TRMS	ISP	advanced_traveler_fares_confirm						x
TRMS	ISP	paratransit_personal_schedule						x
TRMS	ISP	prices						x
TRMS	ISP	transit_deviation_data_received						x
TRMS	ISP	transit_media_emergency_information						x
TRMS	ISP	transit_media_incident_information						x
TRMS	ISP	transit_services_for_advisory_data						x
TRMS	ISP	transit_services_for_guidance						x
TRMS	ISP	transit_user_payments_transactions						x
TRMS	ISP	transit_vehicle_deviations_details						x
TRMS	PIAS	transit_services_for_portables	x	0.33	x			x
TRMS	PMS	parking_lot_transit_response						x
TRMS	PS	financial_reports						x
TRMS	PS	transit_passenger_operational_data						x
TRMS	PS	transit_services_for_deployment						x
TRMS	RTS	confirm_roadside_fare_payment						x
TRMS	RTS	other_services_roadside_response						x
TRMS	RTS	request_transit_user_image						x
TRMS	RTS	transit_roadside_fare_data						x
TRMS	RTS	transit_roadside_fare_payment_debited						x
TRMS	RTS	transit_roadside_fare_payment_request						x
TRMS	RTS	transit_services_for_kiosks						x
TRMS	RTS	transit_services_for_roadside_fares						x
TRMS	RTS	transit_services_for_travelers						x
TRMS	RTS	transit_vehicle_arrival_time						x
TRMS	RTS	transit_vehicle_user_data						x
TRMS	TMS	parking_lot_charge_details						x
TRMS	TMS	toll_price_details						x
TRMS	TMS	transit_fare_details						x
TRMS	TMS	transit_highway_overall_priority						x
TRMS	TMS	transit_ramp_overall_priority						x
TRMS	TMS	transit_road_overall_priority						x
TRMS	TMS	transit_running_data_for_demand						x
TRMS	TMS	transit_services_changes_response						x
TRMS	TMS	transit_services_for_demand						x
TRMS	TRVS	approved_corrective_plan	x	1	x			
TRMS	TRVS	confirm_vehicle_fare_payment	x	1	x			
TRMS	TRVS	other_services_vehicle_response	x	1	x			
TRMS	TRVS	paratransit_transit_driver_instructions	x	1	x			
TRMS	TRVS	request_transit_user_image	x	1	x			
TRMS	TRVS	transit_operator_request_acknowledge	x	1	x			
TRMS	TRVS	transit_services_for_corrections	x	1	x			

**Table 4.5-1 Communications Interfaces Assigned to Each of the Messages**

**Note: Data flows to terminators are all wireline (w).**

PA Source	PA Sink	Message Data Flow	u1t	u1t Fraction	u1b	u <sub>2</sub>	u <sub>3</sub>	w
TRMS	TRVS	transit_services_for_eta	x	1		x		
TRMS	TRVS	transit_services_for_vehicle_fares	x	1		x		
TRMS	TRVS	transit_vehicle_advanced_payment_response	x	1		x		
TRMS	TRVS	transit_vehicle_conditions				x		
TRMS	TRVS	transit_vehicle_fare_data	x	1		x		
TRMS	TRVS	transit_vehicle_fare_payment_debited	x	1		x		
TRMS	TRVS	transit_vehicle_fare_payment_request	x	1		x		
TRVS	RS	transit_vehicle_roadway_preemptions				x		
TRVS	TRMS	fare_collection_vehicle_violation_information				x		
TRVS	TRMS	other_services_vehicle_request	x	1		x		
TRVS	TRMS	paratransit_transit_vehicle_availability	x	1		x		
TRVS	TRMS	request_vehicle_fare_payment	x	1		x		
TRVS	TRMS	transit_conditions_request	x	1		x		
TRVS	TRMS	transit_emergency_details	x	1		x		
TRVS	TRMS	transit_emergency_information	x	1		x		
TRVS	TRMS	transit_operator_emergency_request	x	1		x		
TRVS	TRMS	transit_services_for_eta_request	x	1		x		
TRVS	TRMS	transit_user_vehicle_image	x	1		x		
TRVS	TRMS	transit_vehicle_advanced_payment_request	x	1		x		
TRVS	TRMS	transit_vehicle_arrival_conditions	x	1		x		
TRVS	TRMS	transit_vehicle_collected_trip_data	x	1		x		
TRVS	TRMS	transit_vehicle_deviations_from_schedule	x	1		x		
TRVS	TRMS	transit_vehicle_eta	x	1		x		
TRVS	TRMS	transit_vehicle_fare_payment_confirmation	x	1		x		
TRVS	TRMS	transit_vehicle_location	x	1		x		
TRVS	TRMS	transit_vehicle_location_for_deviation	x	1		x		
TRVS	TRMS	transit_vehicle_location_for_store	x	1		x		
TRVS	TRMS	transit_vehicle_passenger_data	x	1		x		
TRVS	TRMS	transit_vehicle_schedule_deviation	x	1		x		
VS	EM	emergency_request_driver_details	x	1				
VS	EM	emergency_request_vehicle_details	x	1				
VS	ISP	advanced_fares_and_charges_request	x	1				
VS	ISP	advanced_tolls_and_fares_request	x	1				
VS	ISP	advisory_data_request	x	1				
VS	ISP	vehicle_guidance_probe_data	x	1				
VS	ISP	vehicle_guidance_route_accepted	x	1				
VS	ISP	yellow_pages_advisory_requests	x	1				
VS	PMS	advanced_parking_lot_charges_request	x	0.5		x		
VS	PMS	parking_lot_payment_confirmation	x	0.5		x		
VS	PMS	parking_lot_tag_data_collect				x		
VS	RS	ahs_route_data				x		
VS	RS	ahs_vehicle_condition				x		
VS	RS	vehicle_status_details				x		
VS	TCS	toll_payment_confirmation				x		
VS	TCS	toll_tag_data_collect				x		
VS	Other VS	to_other_vehicle					x	
Other VS	VS	from_other_vehicle					x	

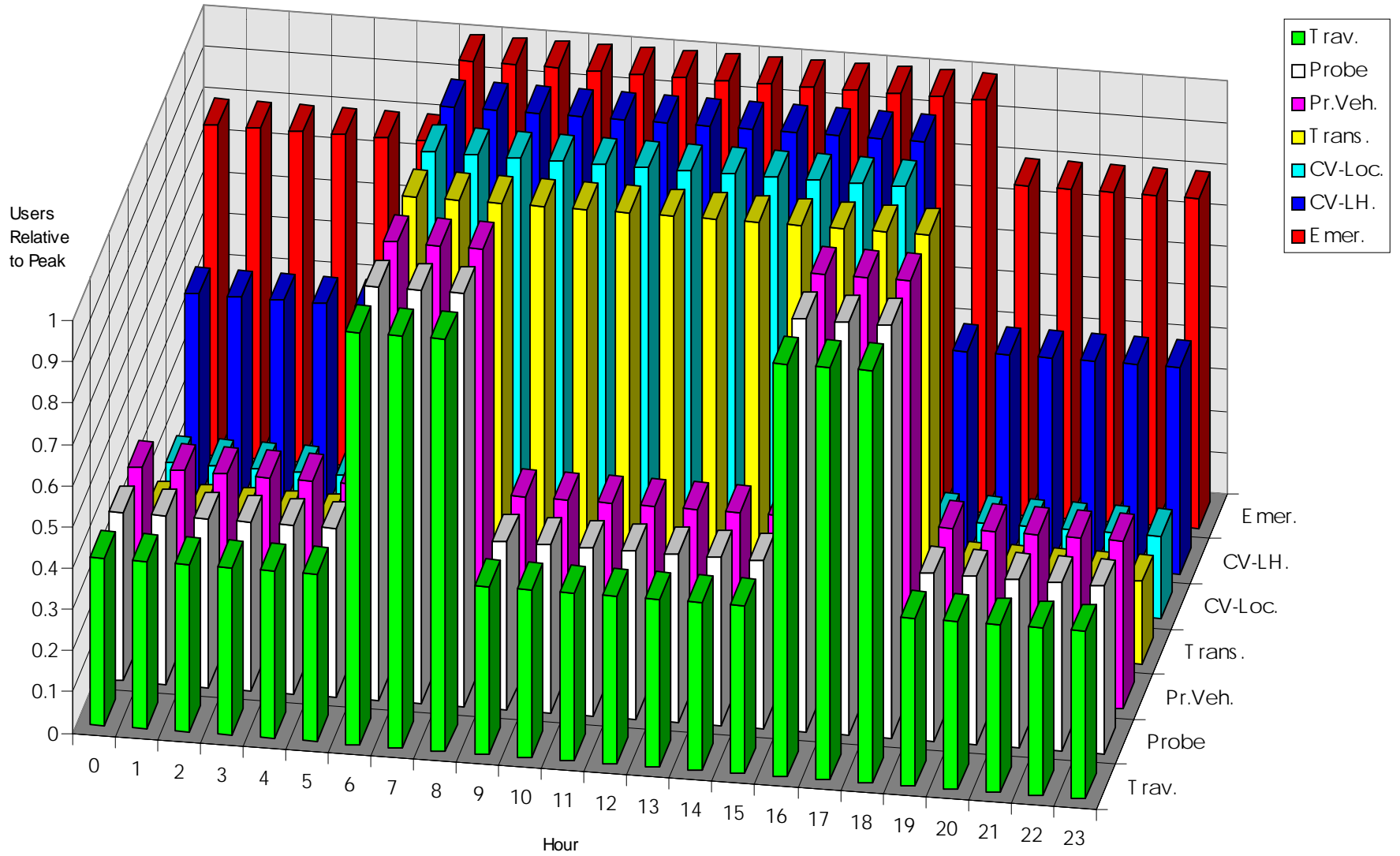
#### **4.6 Usage Profiles for the User Service Groups**

A usage profile indicating the number of users by user service group versus time was developed, and is shown in Figure 4-6.1. The peak period usage is defined as 1.0, and the usage of each user service group relative to that is graphed by user service group and time of day, for a weekday.

Transit and Emergency Management each have a 13-hour peak period, CVO has a 12-hour peak period, and Private Vehicle, Traveler Information (PIAS), and Probes have two, three-hour peak periods. Although these profiles at a first glance may seem as a gross approximation, a communication system needs to be designed for the "busy hour" corresponding the peak period. Thus the exact shape of the temporal profile outside the peak period is not critical.

Usage profiles are used to adjust the number of users for each of the user service groups for both the peak and off-peak periods.

Figure 4.6-1. Usage Profile by Service



#### **4.7 Scenario Infrastructure Model**

The wireline data loading analysis for the “w” interfaces is based directly on the parameters in the Teamwork model in the logical architecture (the wireline data loading results will be shown in Section 6.3). The analysis done shows the total wireline data load between physical subsystems for all of the data flows in the logical architecture. This is the amount of aggregate data flowing between subsystems. In the case of widely-distributed subsystems, such as the RS to TMS wireline link, the result reflects the data rate along a network near the TMS where the data are fully aggregated into a total data rate that would require two DS3-rate links to carry the load (see Table 6.3-3).

The design selections made for the entire network design for the ITS deployment region under consideration are very specific to physical details of the deployment region. Design decisions will be based more on funding availability (capital funding versus lease) and the utilization of existing infrastructure than on technical limitations. Wireline bandwidth is plentiful, and inexpensive relative to any of the other ITS communications interfaces. The ITS architecture allows the use of existing infrastructure to the greatest extent possible, and a selection of a specific wireline technology will not be made here.

One design assumption that drives the second-largest data load for the RS to TMS link is the selection of a video encoding standard. In this document the MPEG-1 standard has been selected. The data rate is 1.5 Mbps. This decision was based on the fact that MPEG-1 provides a high quality full-motion video image that can be readily demonstrated today. The development of inexpensive MPEG-1 encoders and decoders has been completed, and the cost will decline rapidly in the near term. This assumption can be revisited in the future when the time for an actual deployment is nearer. The tradeoff between the cost of the encoder/decoder pair and the cost of transport should be studied then, because of the rapid developments in the area of video encoding.



## 5. MESSAGE DEFINITION

The data flows of the logical architecture form the messages used to provide ITS services. The only addition to the data flows to allow them to act as messages was to append a `message_id` header of 18 bits. The `message_id` header provides the receiving subsystem the information on which message is being transmitted, which in turn provides the receiver with information on the data fields that follow along with their sizes. Each `message_id` has a fixed definition for the information fields which are contained in that message. Each of the fields are of fixed length. Nothing has been done at this point to optimize the messages for a particular communications medium. It is likely that standards efforts and commercial ventures will optimize them to minimize the communications requirements and the cost of service.

The physical entities and the communications interfaces required for the ITS architecture are shown in Figure 5.1-1, the Level 0 AID. The interfaces are shown between the entities, with *u* interfaces indicating wireless. The wireline interfaces are indicated by a *w*.

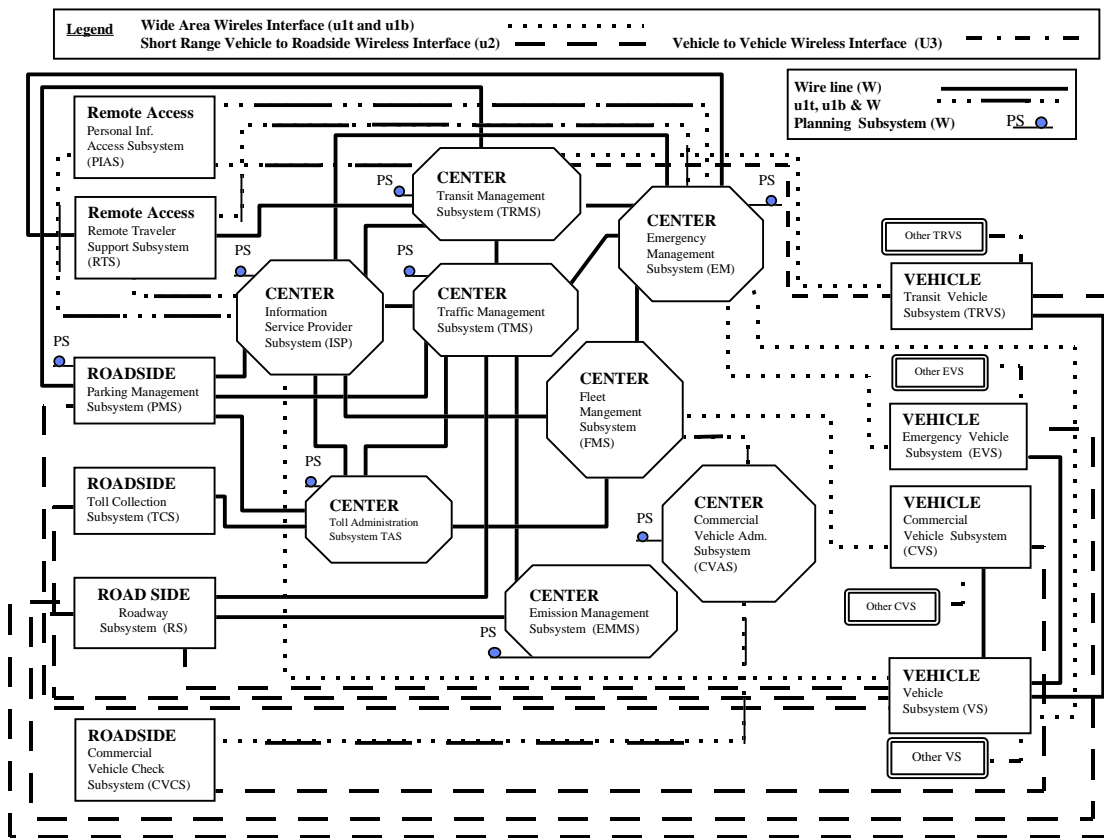


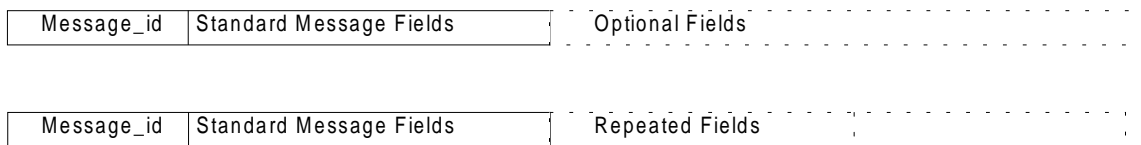
Figure 5.1-1 Level 0 Architecture Interconnect Diagram for the National ITS Architecture

## 5.1 Message Definition Methodology

The message set consists of the data flows that are communicated between physical subsystems for the entire logical architecture. For this analysis, the baseline logical architecture dated January 22, 1996 was used. Some changes were made to the logical architecture after that date and were tracked in the logical architecture as changes to the January 22, 1996 baseline. The January 22, 1996 logical architecture had to be used to allow time for the performance of the data loading analyses, and more importantly the communication simulations (which are very time intensive) prior to the Final Program review held on April 2, 1996.

## 5.2 Message Structure

In order to allow the data flows to form messages, an 18-bit message\_id header has been added to each of the data flows. The message structure and overhead for the application layer are described in Figure 5.2-1.



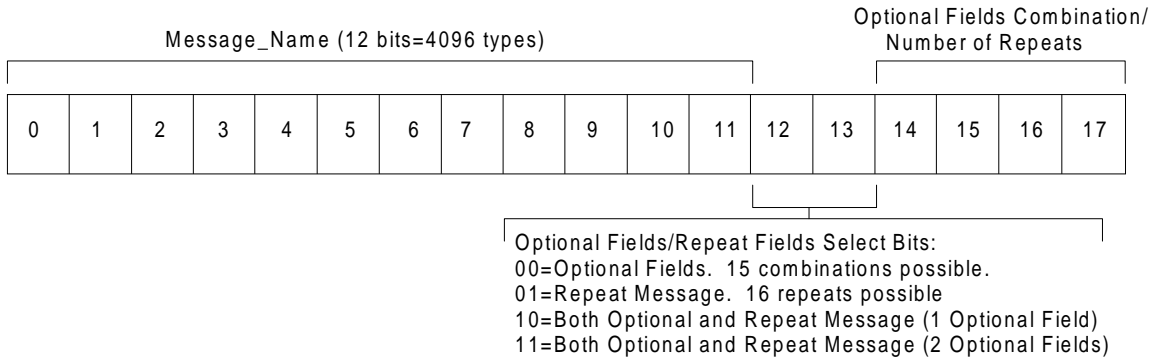
**Figure 5.2-1 Examples of Message Structures**

(Top) Example of a message with optional fields.

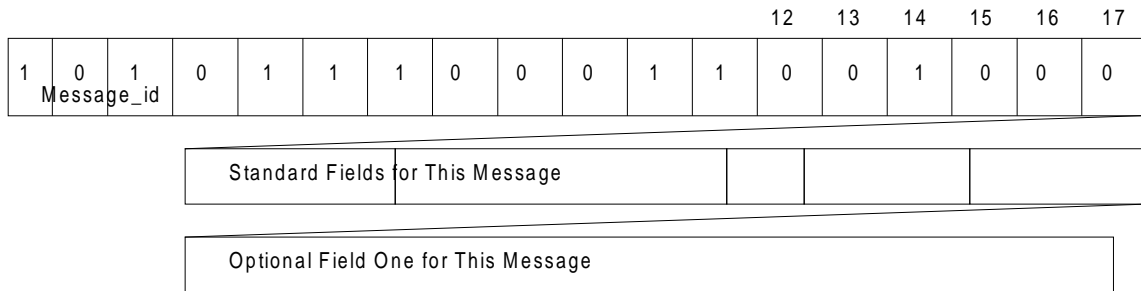
(Bottom) Example of a message with repeated fields.

Each of the message fields used is of fixed length, and the messages are all of a pre-determined length. Messages consist of a message\_id header followed by a small number of pre-defined standard message fields, and possibly optional fields or repeated fields. The message\_id tells the receiver which information fields follow in a given message. Most of the messages consist of a small number of standard message fields. The message\_id field, shown in Figure 5.2-2, consists of the message\_name, optional fields/repeat fields select bits and four bits to denote the optional fields and/or number of repeats to follow. The optional fields are large, generally text fields that are transmitted only with a minority of the messages. The longer text fields required to provide specialized data are optional fields, and are only transmitted in response to a request for text information. When transmitted, their presence is indicated in one of the four optional field bits in the message\_id header. Up to 15 combinations of optional fields can be accommodated. An optional-field message is shown in Figure 5.2-3.

Many of the data flows from the logical architecture can be broken up into standard fields, optional fields, and repeated fields. This has been left for the standards bodies to complete during optimization efforts, because it is largely dependent on the communications media selected.



**Figure 5.2-2 Details of the Message\_ID Field which Allows Standard, Optional, and Repeated Fields to be Appended to the Message**



**Figure 5.2-3 Example of an Optional-Field Message**

Repeated fields are a subset of the initial standard message fields that are repeated to provide a complete message. They are useful when the number of fields to follow is not fixed (e.g., a route guidance message has more sets of route information for a longer route). An example of a message with three repeats of repeat fields is shown in Figure 5.2-4.



**Table 5.3-1 Market Package Deployment by Time Frame  
(All are Deployed in Urbansville and Thruville in 2012)**

<b>Region*</b>	<b>Year</b>	<b>Market Package Name</b>
u	1997	Transit Vehicle Tracking
u	1997	Transit Fixed-Route Operations
u	1997	Demand Response Transit Operations
u	1997	Broadcast Traveler Information
u	1997	Interactive Traveler Information
u	1997	Probe Surveillance
u	1997	Fleet Administration
u	1997	Emergency Response
u	1997	Mayday Support
u	2002	Transit Vehicle Tracking
u	2002	Transit Fixed-Route Operations
u	2002	Demand Response Transit Operations
u	2002	Transit Passenger and Fare Management
u	2002	Transit Security
u	2002	Transit Maintenance
u	2002	Multi-modal Coordination
u	2002	Broadcast Traveler Information
u	2002	Interactive Traveler Information
u	2002	Yellow Pages and Reservation
u	2002	Integrated Transportation Management/Route Guidance
u	2002	Probe Surveillance
u	2002	Fleet Administration
u	2002	Freight Administration
u	2002	Electronic Clearance
u	2002	CV Administrative Processes
u	2002	International Border Electronic Clearance
u	2002	Weigh-In-Motion
u	2002	Roadside CVO Safety
u	2002	Emergency Response
u	2002	Mayday Support
r	2002	Transit Passenger and Fare Management
r	2002	Broadcast Traveler Information
r	2002	Fleet Administration
r	2002	Freight Administration
r	2002	Electronic Clearance
r	2002	CV Administrative Processes
r	2002	International Border Electronic Clearance
r	2002	Weigh-In-Motion
r	2002	Roadside CVO Safety
r	2002	Emergency Response
r	2002	Mayday Support
r	2012	Transit Vehicle Tracking
r	2012	Transit Fixed-Route Operations
r	2012	Demand Response Transit Operations
r	2012	Transit Passenger and Fare Management
r	2012	Transit Security
r	2012	Transit Maintenance
r	2012	Broadcast Traveler Information
r	2012	Interactive Traveler Information
r	2012	Yellow Pages and Reservation
r	2012	Integrated Transportation Management/Route Guidance

**Table 5.3-1 Market Package Deployment by Time Frame  
(All are Deployed in Urbansville and Thruville in 2012)**

Region*	Year	Market Package Name
r	2012	Fleet Administration
r	2012	Freight Administration
r	2012	Electronic Clearance
r	2012	CV Administrative Processes
r	2012	International Border Electronic Clearance
r	2012	Weigh-In-Motion
r	2012	Roadside CVO Safety
r	2012	On-board CVO Safety
r	2012	Emergency Response
r	2012	Mayday Support
i	1997	Transit Vehicle Tracking
i	1997	Transit Fixed-Route Operations
i	1997	Demand Response Transit Operations
i	1997	Broadcast Traveler Information
i	1997	Probe Surveillance
i	1997	Fleet Administration
i	1997	Emergency Response
i	2002	Transit Vehicle Tracking
i	2002	Transit Fixed-Route Operations
i	2002	Demand Response Transit Operations
i	2002	Transit Passenger and Fare Management
i	2002	Transit Maintenance
i	2002	Broadcast Traveler Information
i	2002	Interactive Traveler Information
i	2002	Integrated Transportation Management/Route Guidance
i	2002	Probe Surveillance
i	2002	Fleet Administration
i	2002	Freight Administration
i	2002	CV Administrative Processes
i	2002	Electronic Clearance
i	2002	International Border Electronic Clearance
i	2002	Weigh-In-Motion
i	2002	Roadside CVO Safety
i	2002	Emergency Response
i	2002	Mayday Support

\*Region designations: u = urban; r = rural; i = inter-urban

The complete set of messages available for each scenario region and time frame are provided in the data loading models shown in Appendix F.

## **6. DATA LOADING METHODOLOGY AND RESULTS**

The purpose of the data loading analysis is to provide an estimate of the data transmission requirements for a candidate (or evaluatory) deployment of the ITS Architecture. These estimates are used to size, and prove the feasibility of, the candidate communication systems considered as possible implementations, and, in turn, demonstrate the soundness of the ITS Architecture itself.

The results of the data loading models derived in this section are fed as inputs to the communication simulations (discussed at length in Section 8). They also serve as an input to the cost models, since the cost of communications is a major component of the overall cost of an ITS system. In the data loading analysis, the same three scenario regions (Urbansville, Thruville, and Mountainville) are studied for the same three time frames (1997, 2002, and 2012). The candidate deployment is the evaluatory design, as defined in the Evaluatory Design Document.

The two key outputs from the data loading task determined:

- Average peak-period data loads on all of the communications interfaces.
- Statistics of message transmission to drive the communications simulations.

These simulations provide the real-time communications system performance (i.e., accounting for the instantaneous fluctuations of loading) for the evaluatory design considered. For the case where a shared infrastructure is used, the network will have already been designed for the observed peak loading throughout the ITS geographic coverage area for other applications (particularly voice or other data traffic).

The data loading task here takes inputs from the logical architecture, the physical architecture, the evaluatory design, and the implementation strategy. The data flows in the logical architecture form the messages in the data loading analysis, after the message\_id header is added.

The physical architecture defines the assignment of the logical architecture specifications into physical ITS subsystems. This assignment defines which data flows cross between physical subsystems, and must therefore be transmitted on communications interfaces.

Deployment information from the implementation strategy is used to make a determination of which market packages (and therefore which messages) will be available in each of the scenario regions/time frames.

National statistics are used to determine the potential user population for the evaluatory design assumptions. Penetration values for users of ITS services are defined by market package from information from the Evaluatory Design Document.

The data loading task also entails assigning messages to communications interfaces (in many cases multiple interfaces), and defining the fraction of the total data load to be carried over each communications interface.

Because of the significant time lead required for the generation of the data loading models, and the preparation and running of the simulations, the data loading analysis presented here is for the Evaluatory Design based on the ITS National Architecture dated January 22, 1996. This design should be viewed as a candidate ITS deployment. It includes a reasonable set of assumptions to model an actual deployment. These assumptions include ITS system sizing, communications network sizing (using 1993 network deployments without any capacity upgrading or additional competing systems through the 2012 time frame), message definitions (which have not yet been optimized to provide a good balance between ITS system performance and cost, and are not compressed), frequencies of use of each message by user type, and user penetration.

It is expected that there will be variations in the design assumptions, such as penetration, message sizes and frequencies of use, etc. with specific deployments in the future. With the thousands of assumptions used in the model, some variables will increase, and others will decrease. To be extra conservative, the simulations account later for unexpected variations by using the data loading outputs with additional, severe, worst case assumptions, e.g., no cellular infrastructure expansion, no splitting of load between competing technologies, worst case traffic incident, and so on.

The fundamental conclusions based on the data loading analysis and the simulations to follow, although for a single overall design, indicate that the communications requirements can be accommodated using existing and planned technology. This single conclusion is insensitive to any expected variations in the assumptions contained within the data loading analysis. It is also intuitive, that as the communications requirements of ITS and other communications-intensive applications increase over time, the various communications technologies described in Section 7 will continuously increase in capacity to meet the increased demand.

It is finally worth noting that because the data loading analysis requires so many thousands of assumptions, it is difficult to perform sensitivity studies within the constraints of the National ITS Architecture development effort. The variables that are the most critical to the final result are the penetration assumptions, because they are factors applied across groups of messages. Again, the penetration values were taken directly from the evaluatory design, using the "high" estimate for the worst-case analysis. Since the purpose of the data loading analysis is to prove the validity of the communications systems sizing, the worst case is studied. Because the effect of changing the penetration is linear across entire user service groups, estimates of the sensitivity of penetration on the average link loads are trivial to prepare from the data loading results, which were determined by user service group. The effect of penetration on the instantaneous link performance can only be determined by simulations. Unfortunately, a series of simulations would be required, which would be quite costly.

The per-user data loading models are very detailed and show the link data load resulting from each message. The sensitivity of the link data load to any of the message sizes and frequencies of use can be readily determined.



## 6.1 Data Loading Models

Seven user service groups of distinct usage patterns were defined. Where groups of users within a user service group with differing usage patterns could be defined, the user service groupings were sub-divided. An example is the division of local CVO from long-haul CVO. The grouping results in seven user service groups: Travelers (PIAS users), CVO-Local, CVO-Long Haul, Private Vehicles, Transit, Emergency Management, and Probes.

The set of market packages of interest to each user service group were defined, which in turn determined the message set for that user service group. Frequencies of use were defined for each message for each user service group. Finally, the statistics on the transmission of messages on each link were calculated, and the average data rates on each link were calculated.

Data loading models were calculated for each service individually, for both a peak and off-peak period that has been defined for each service. The most important goal of the data loading analysis is to determine the peak-period average data rates for use in communications system sizing. A two-level (peak/off-peak) model for each service allows the number of users to be varied through the day, so that the resulting data rate can be included as a function of time, giving a more accurate total data rate profile over time. It is critical to note that the hour(s) with the highest total data rate from all services will be used in sizing the communications links.

## 6.2 Wireless Data Loads

The wireless interfaces consist of the two-way wide area ( $u_{1t}$ ) wireless interface, the broadcast wide area ( $u_{1b}$ ) interface, the short range, DSRC, ( $u_2$ ) interface, and the vehicle-to-vehicle ( $u_3$ ) interface. Data loads determined for these are shown in the next three sections, with the exception of the  $u_3$  interface. The  $u_3$  interface, intended for AHS applications, is for dedicated systems that are still in the early research phase and which are under study in another program.

### 6.2.1 Two-Way Wireless Data Loads

Per-user peak-period data loading models for the  $u_{1t}$  interface by user service group for each of the scenarios were completed and are shown in Appendix F. There is a total of 24 data loading models.

These per-user peak-period results were then used to determine the off-peak loads, which are a fraction of the peak period loads, based on the usage profile by service (see Figure 4.6-1).

These results were then multiplied by the number of potential users in the scenario, and then divided by the total area of the scenario area to obtain the data loads per square mile for the charts. This step allows the calculation of the data load for each of the communications sites, regardless of the number used, given the area of coverage of each.

The results of the data loading analysis are shown graphically in Figures 6.2-1 through 6.2-24. The charts are ordered with the 1997 results first, then the 2002 results, followed by those for 2012. For each of the time frames there are 9 charts: Urbansville forward, reverse, and total data loads; Thruville forward, reverse, and total data loads; and Mountainville forward, reverse, and total data loads (Mountainville has no deployment in 1997).

The charts show the data loads in bits per second per square mile, by user service group, by hour of the day, for a weekday. The load for any wireless communications subsystem can then be

calculated by multiplying these results by the area of coverage of the communications subsystem. It should be noted that whether during or outside the peak periods, these results are average loads; statistical variations are handled in the communications simulations.

The data loading analysis results charted in Figures 6.2-1 through 6.2-24 are summarized in Table 6.2-1.

Figure 6.2-1 Data Loading by Service - Forward, 1997, Urbansville

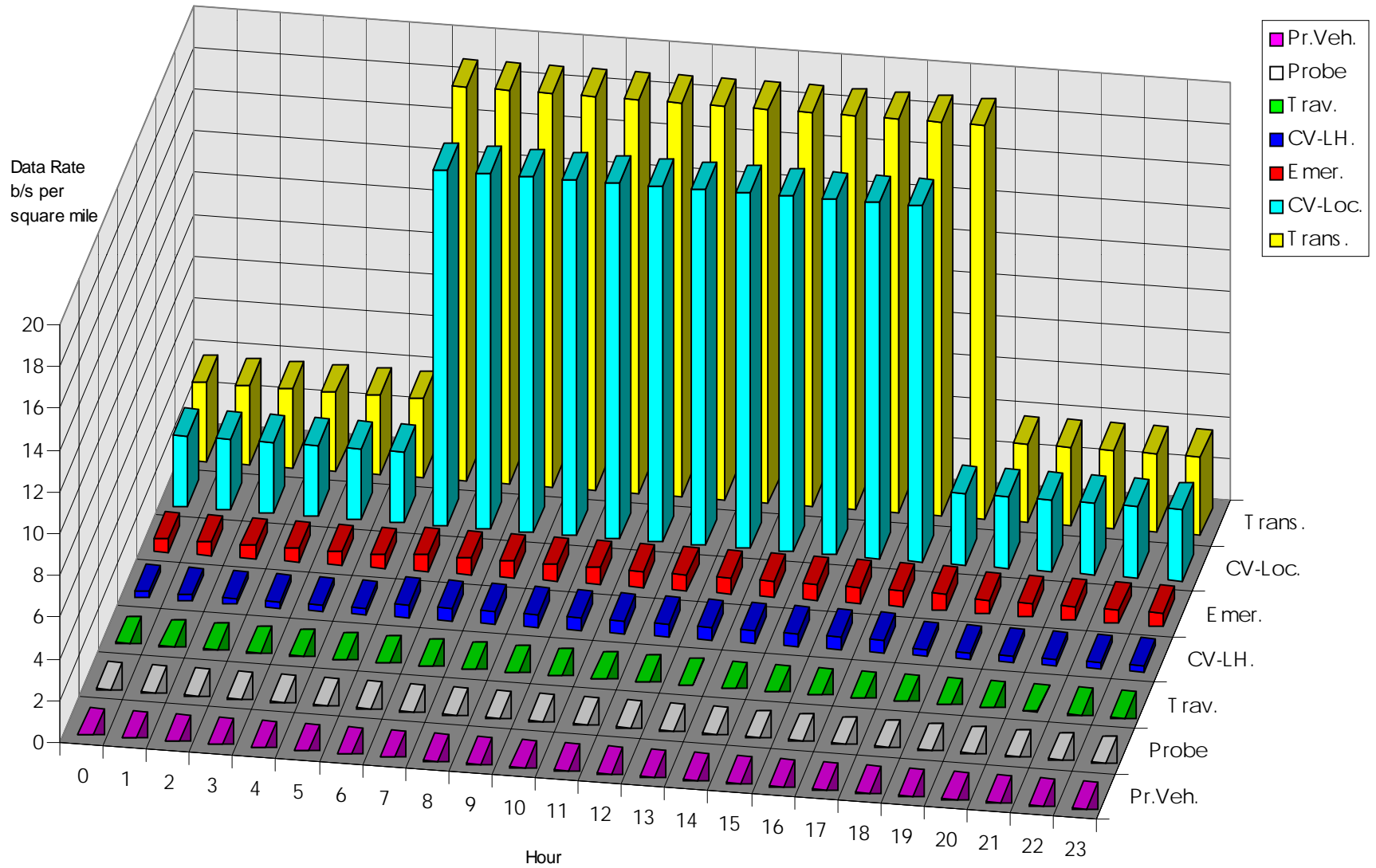


Figure 6.2-2 Data Loading by Service - Reverse, 1997, Urbansville

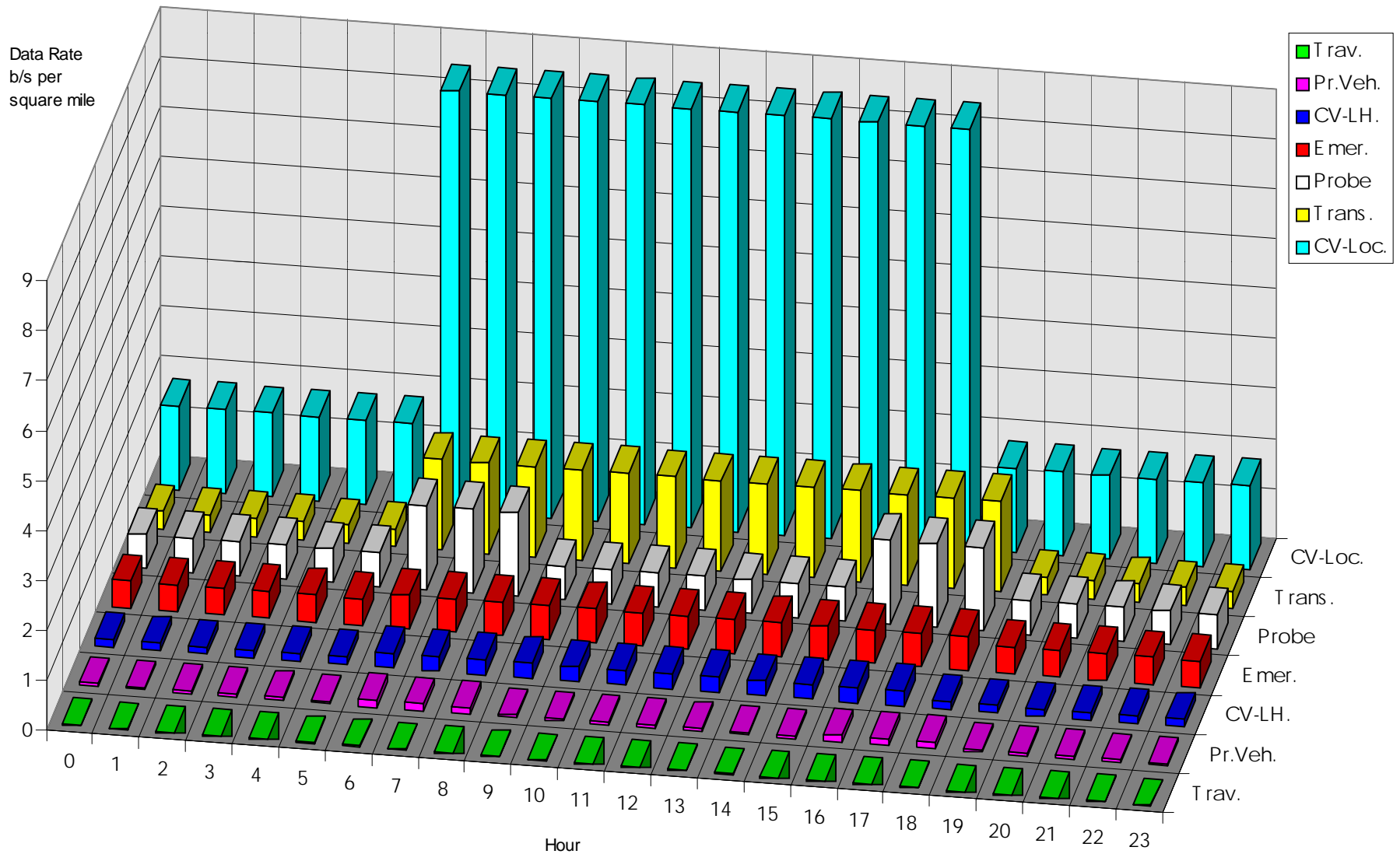


Figure 6.2-3 Total Data Loading, 1997, Urbansville.

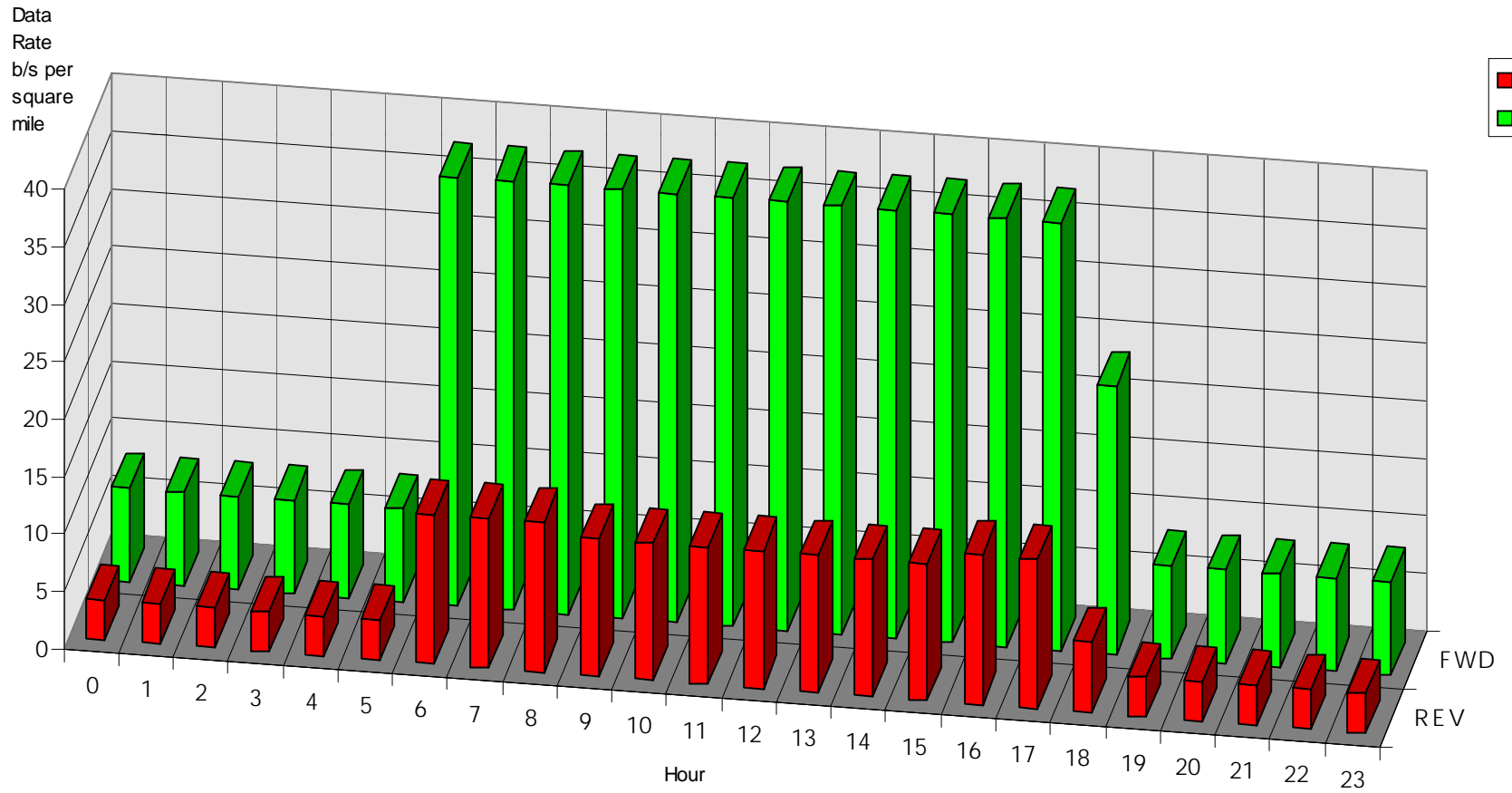


Figure 6.2-4 Data Loading by Service - Forward, 1997, Thruville.

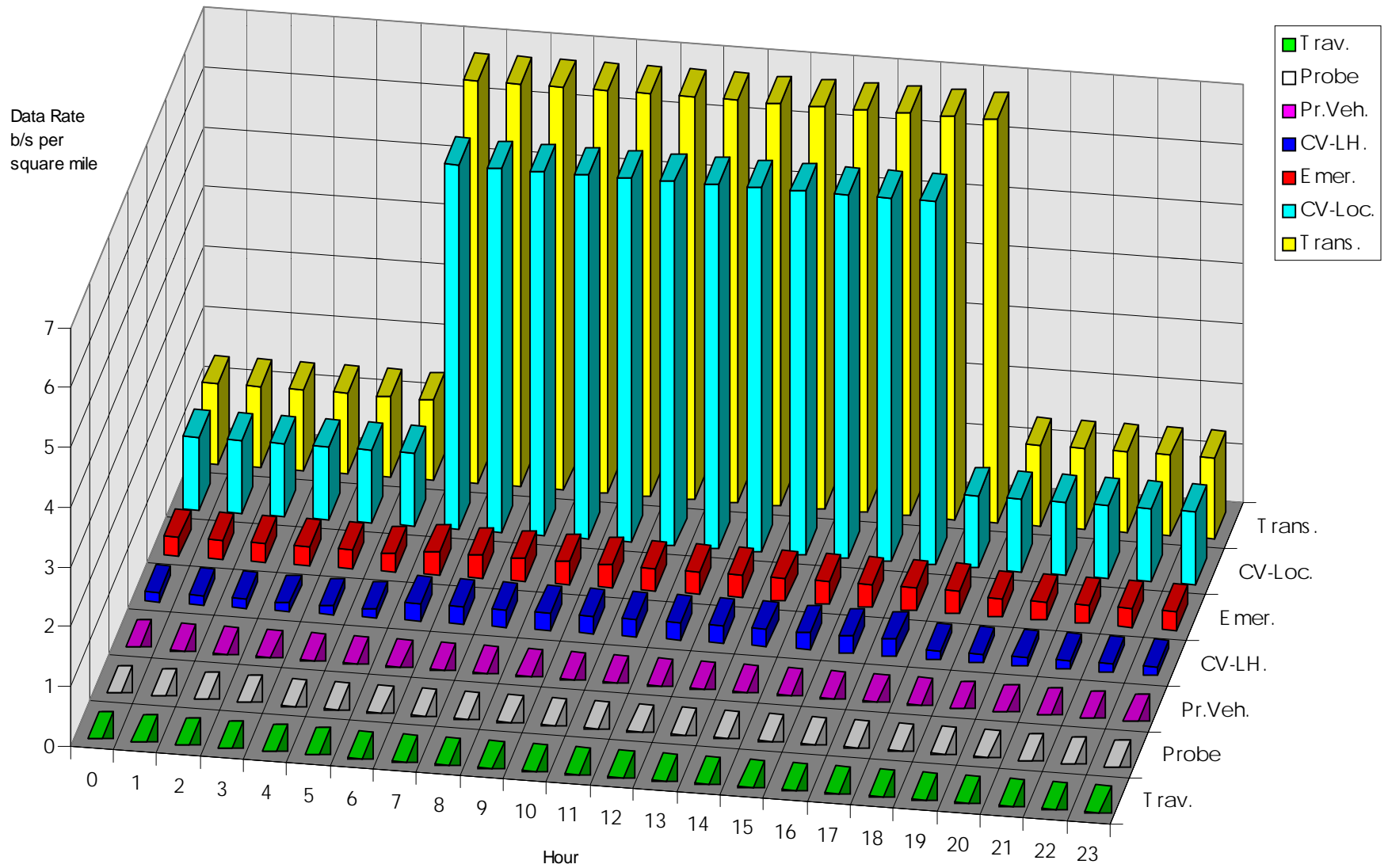


Figure 6.2-5 Data Loading by Service - Reverse, 1997, Thruville

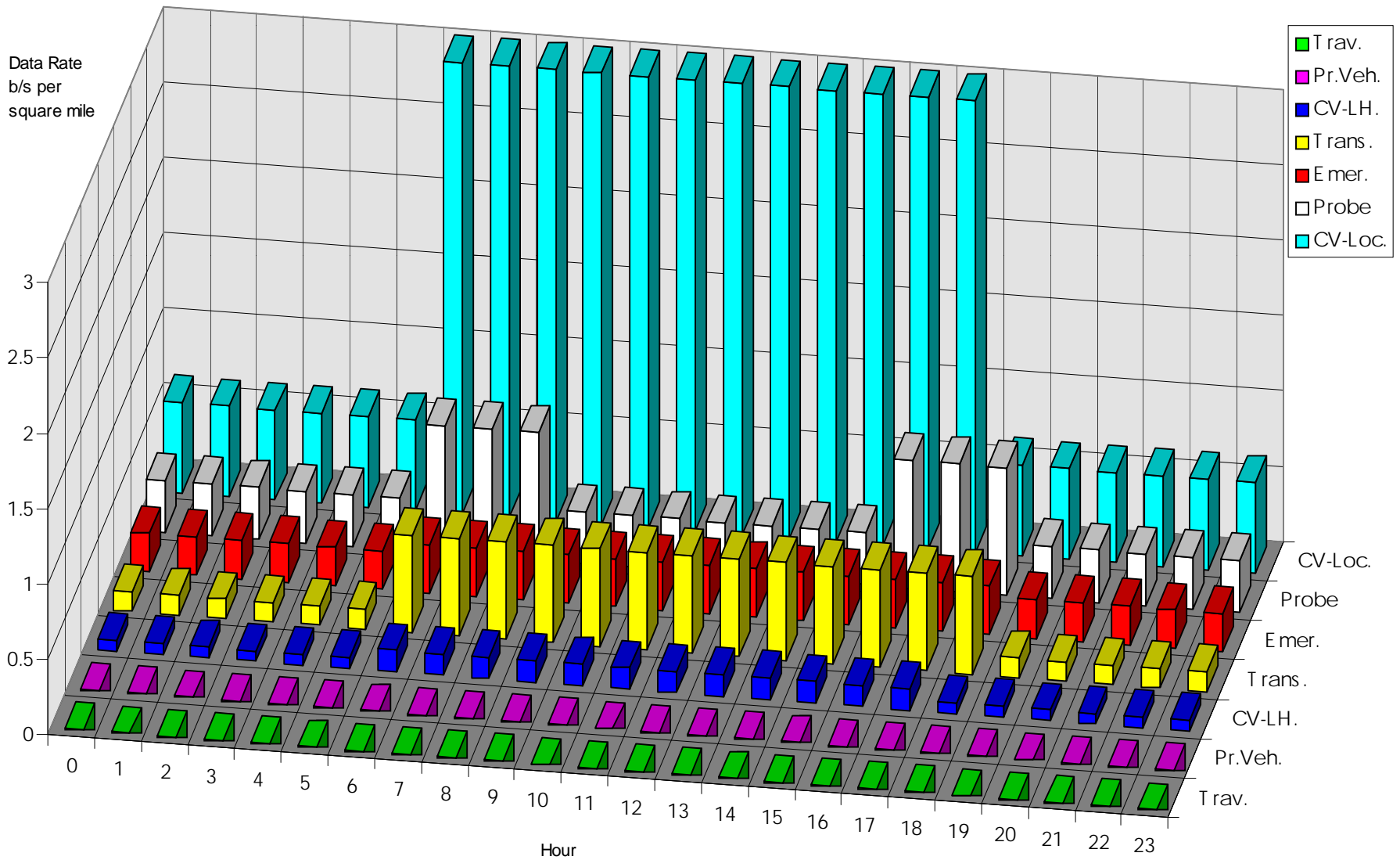


Figure 6.2-6 Total Data Loading, 1997, Thruville

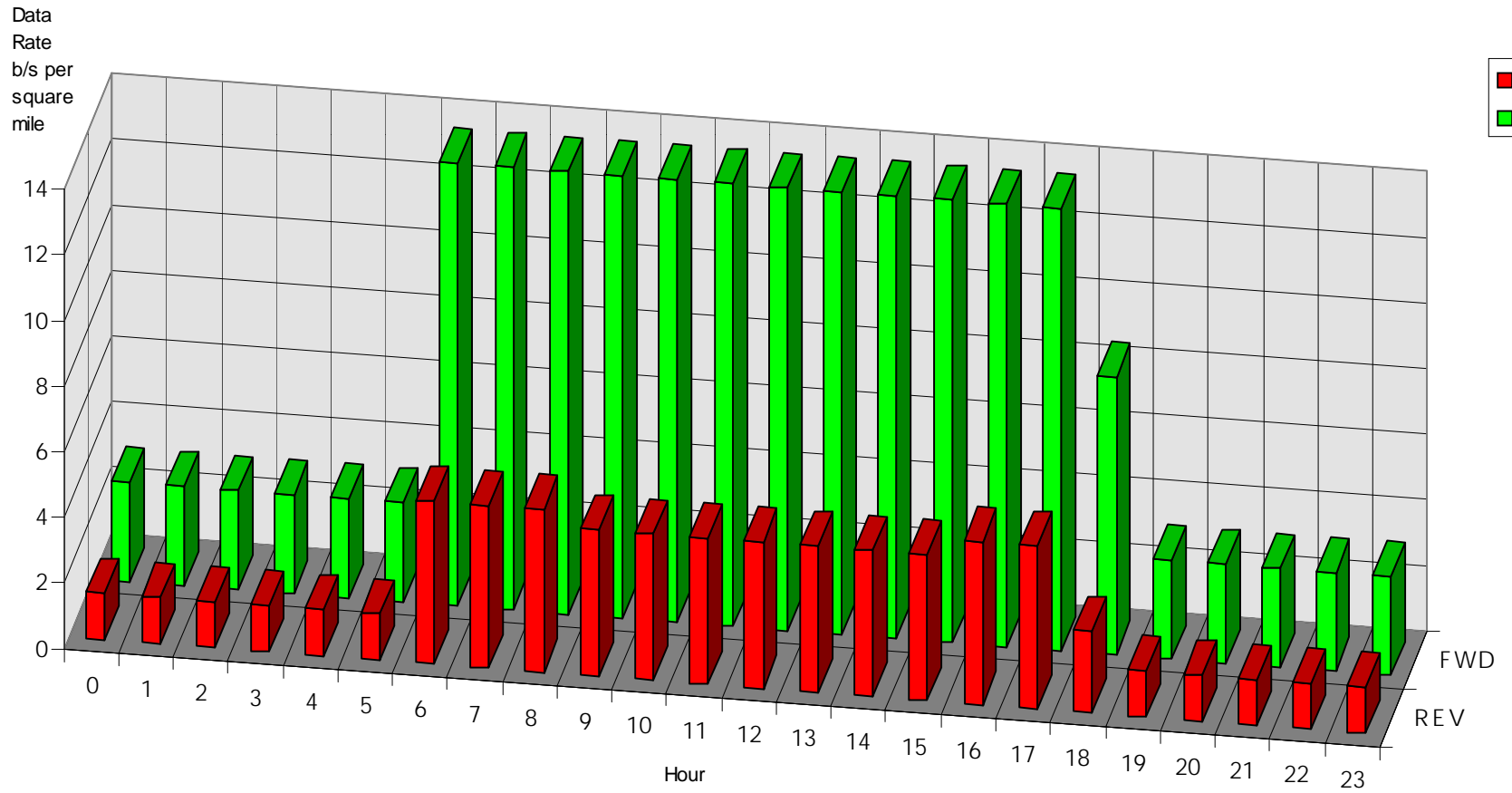




Figure 6.2-7 Data Loading by Service - Forward, 2002, Urbansville.

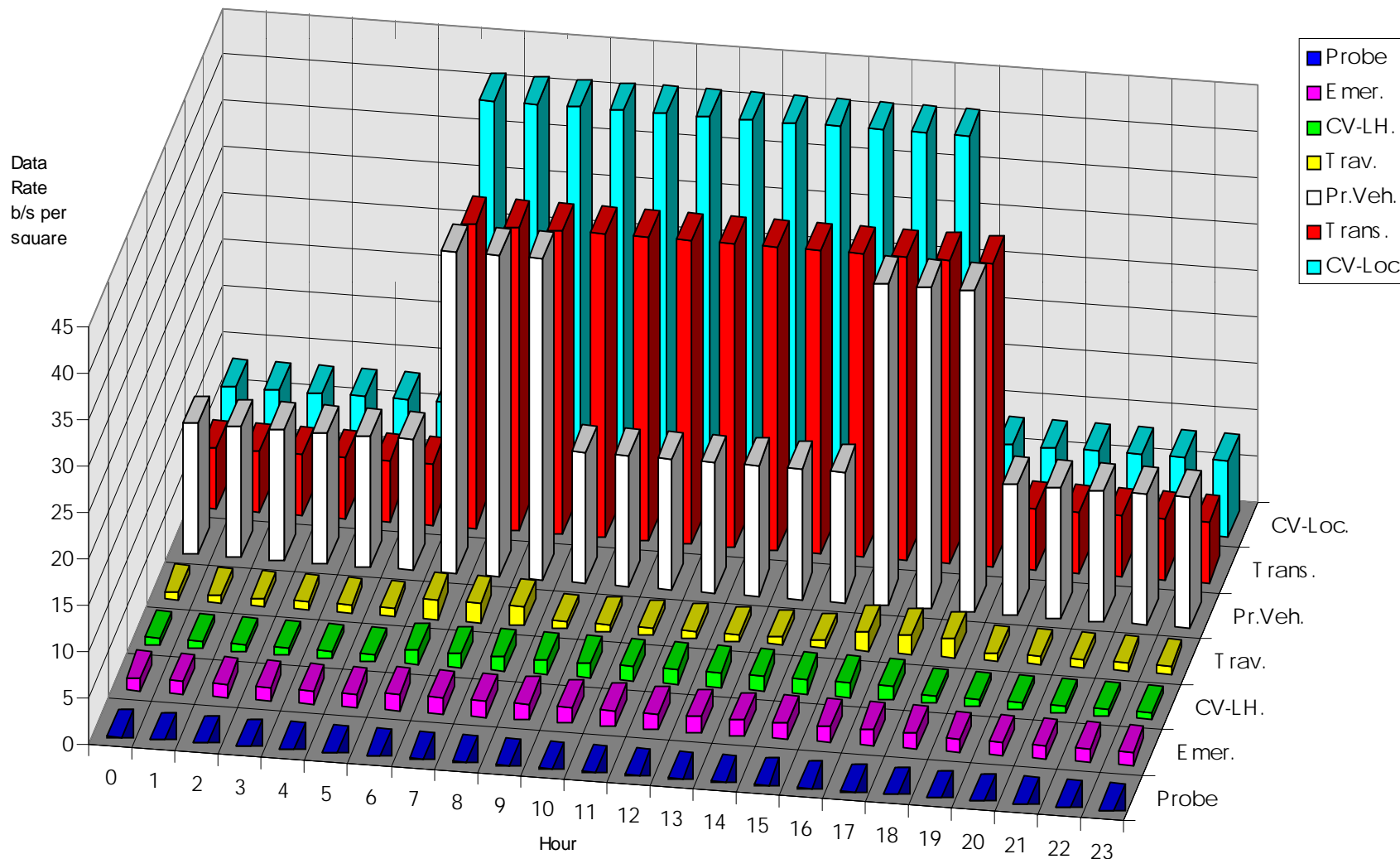


Figure 6.2-8 Data Loading by Service - Reverse, 2002, Urbansville.

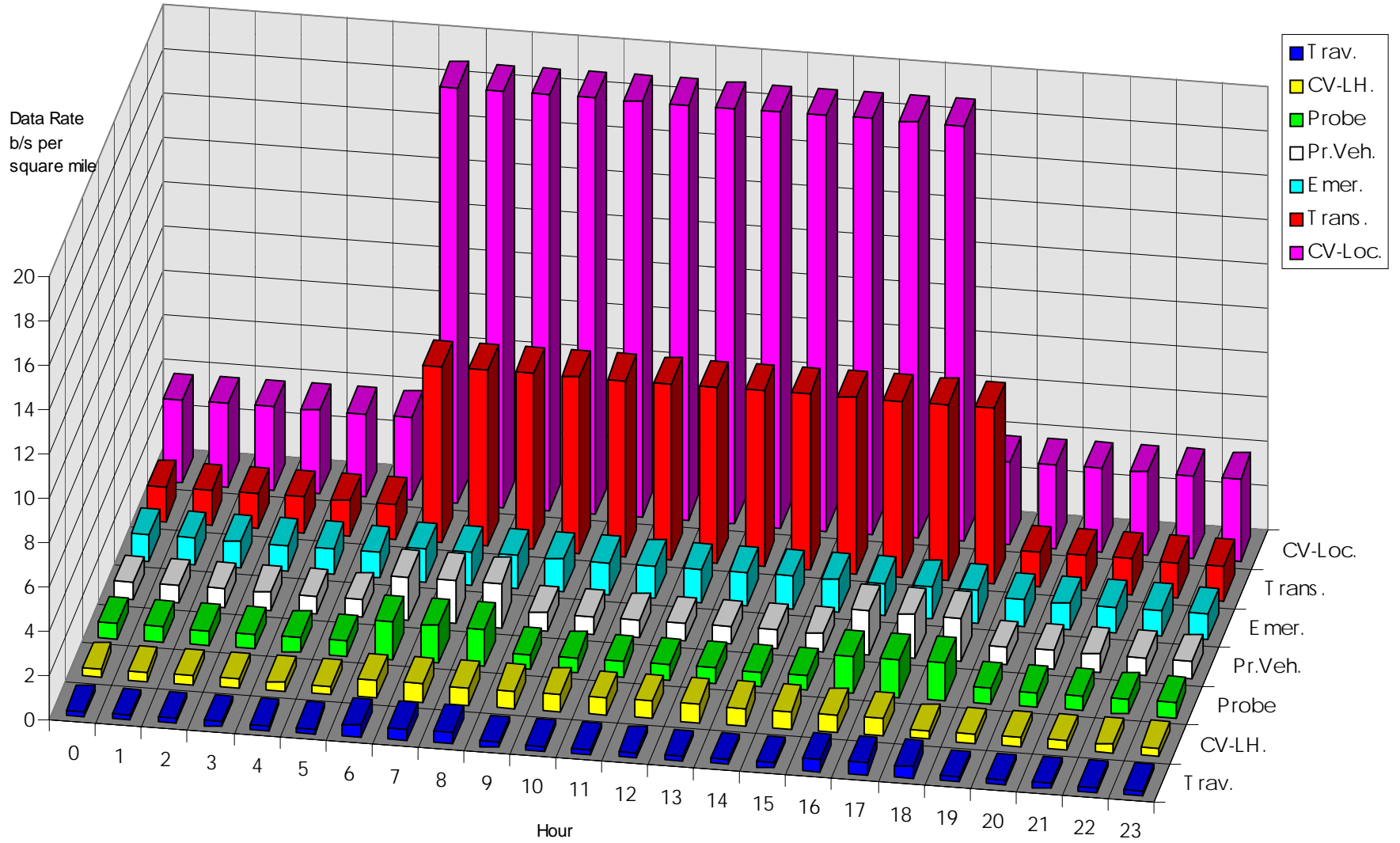


Figure 6.2-9 Total Data Loading, 2002, Urbansville.

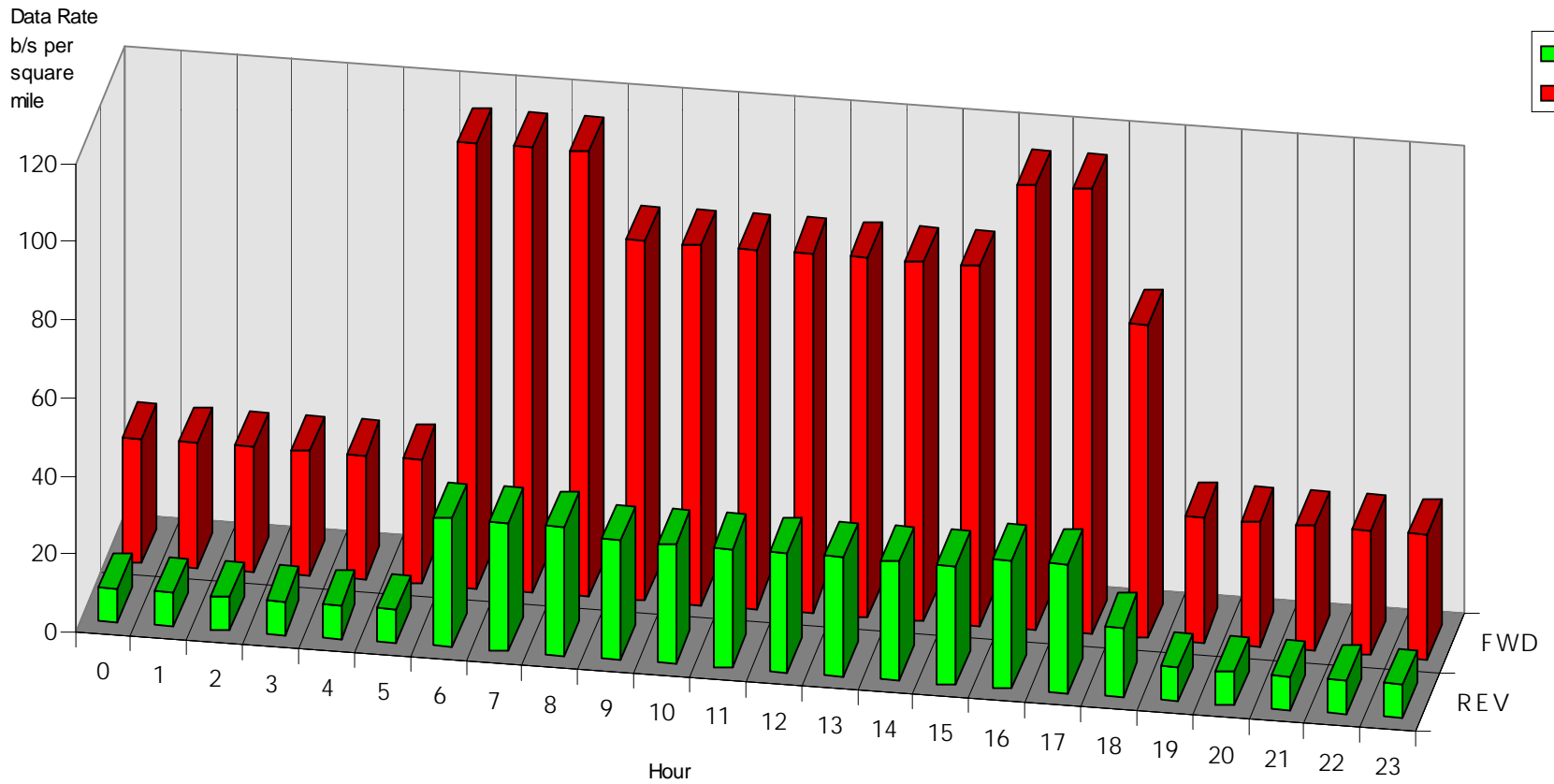


Figure 6.2-10 Data Loading by Service - Forward, 2002, Thruville.

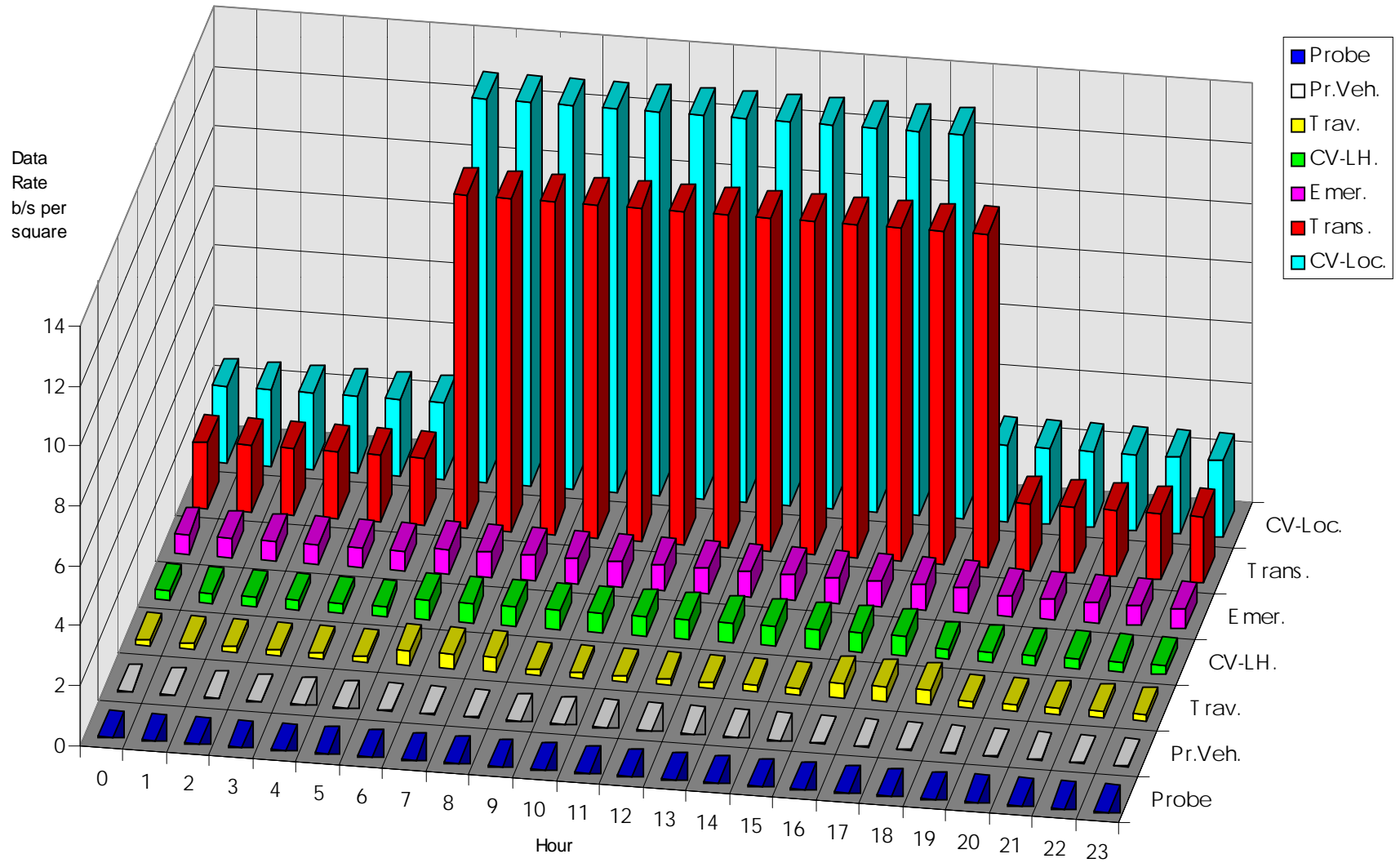


Figure 6.2-11 Data Loading by Service - Reverse, 2002, Thruville.

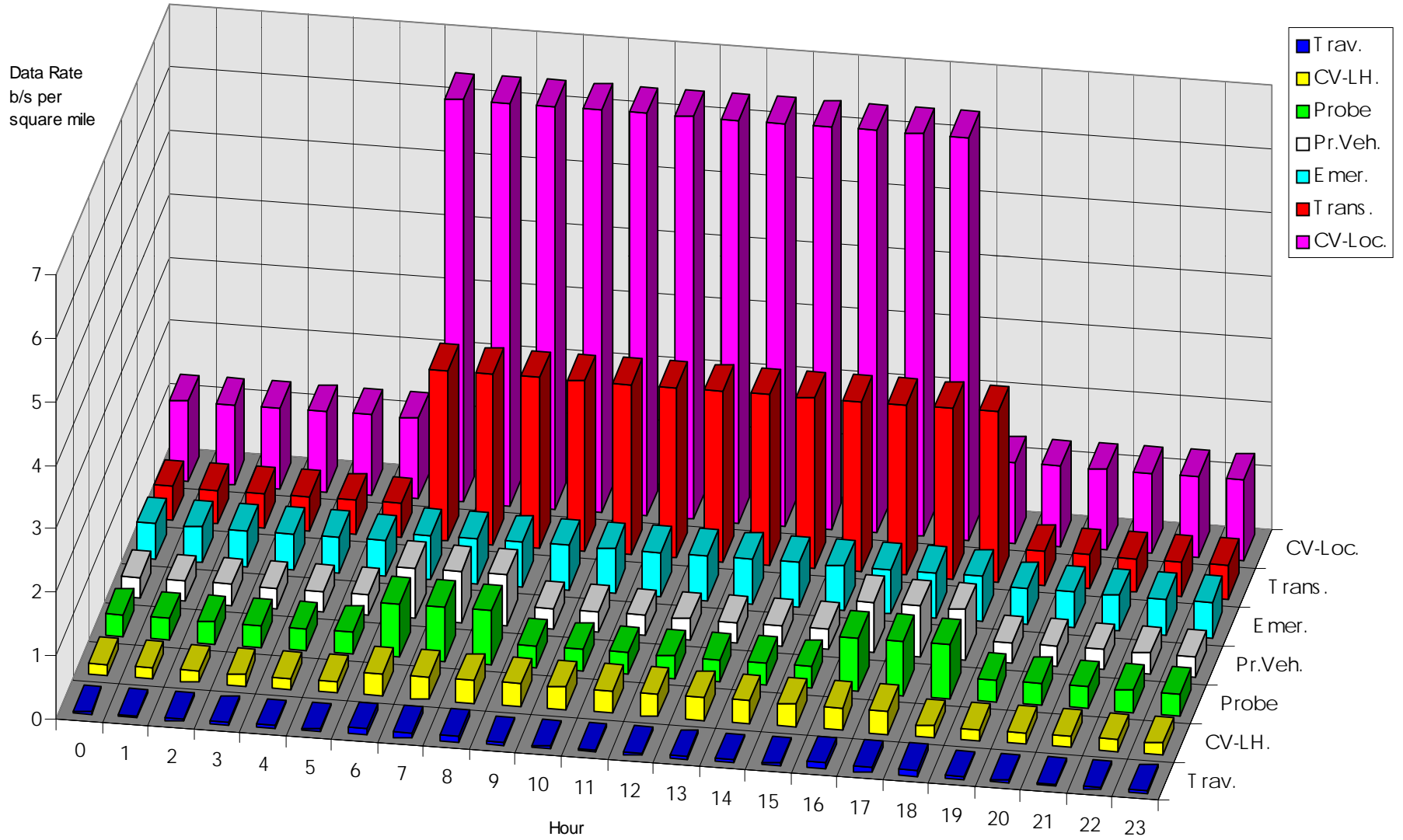


Figure 6.2-12 Total Data Loading, 2002, Thruville

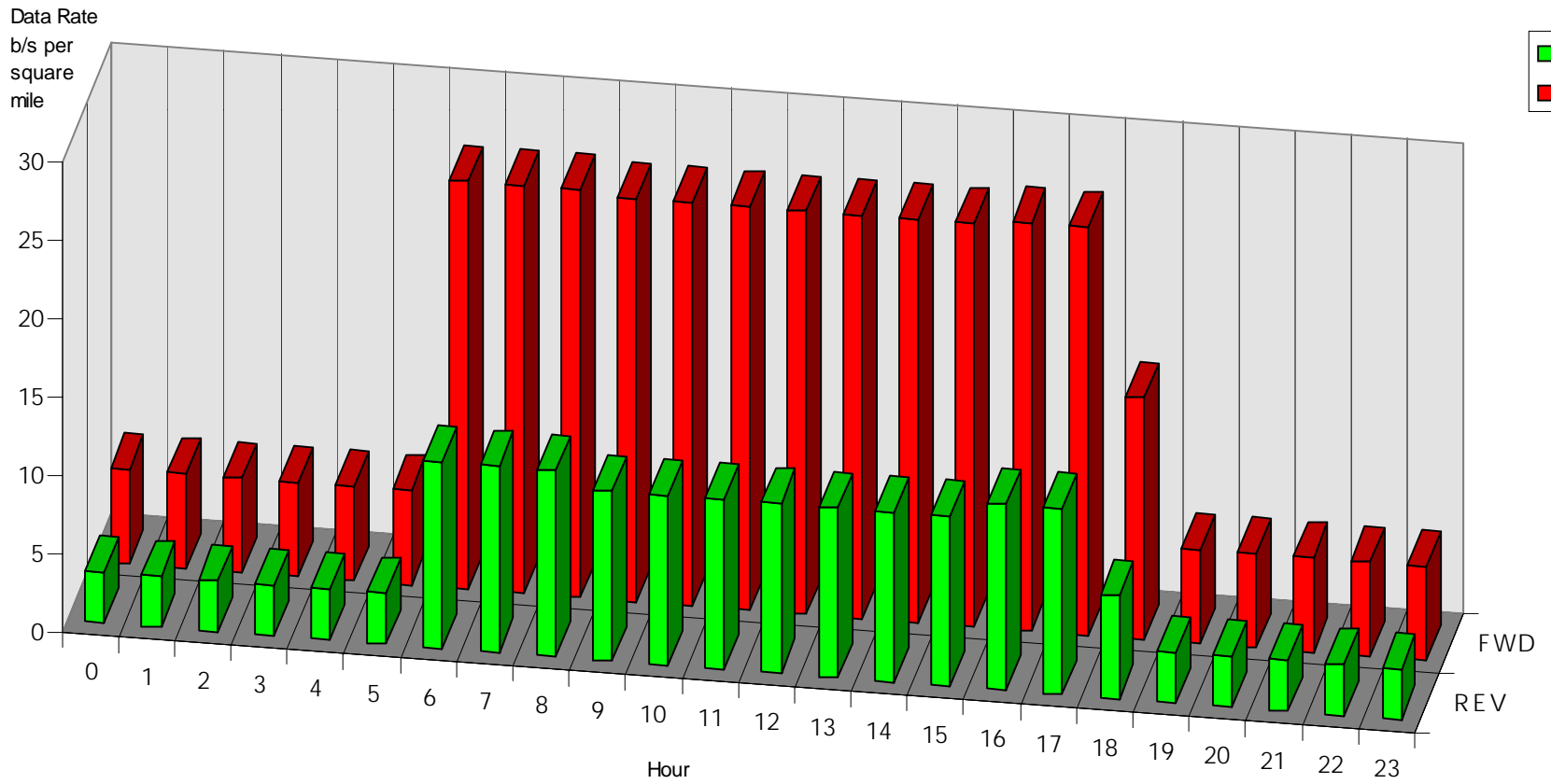


Figure 6.2-13 Data Loading by Service - Forward, 2002, Mountainville.

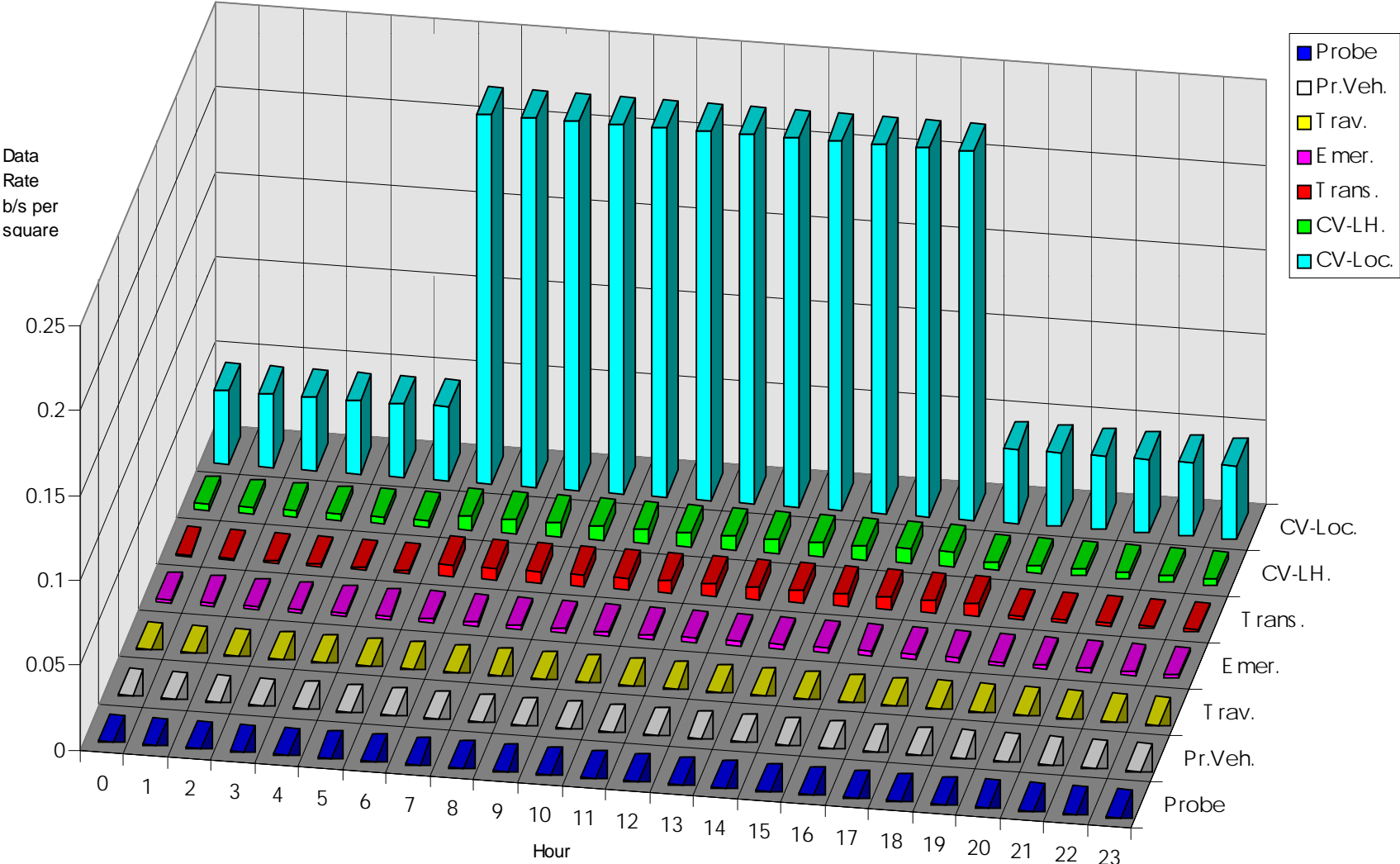


Figure 6.2-14 Data Loading by Service - Reverse, 2002, Mountainville.

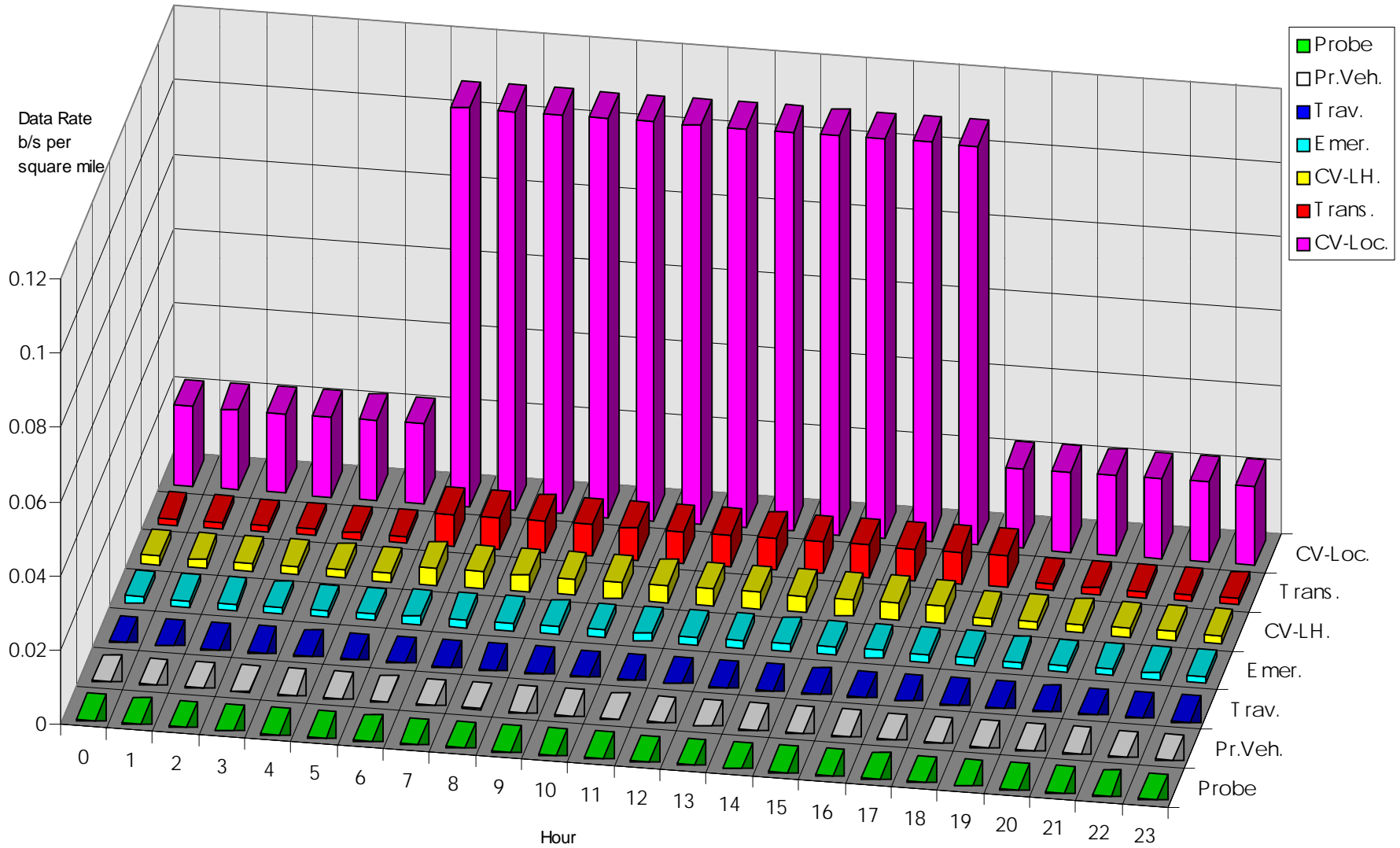




Figure 6.2-15 Total Data Loading, 2002, Mountainville.

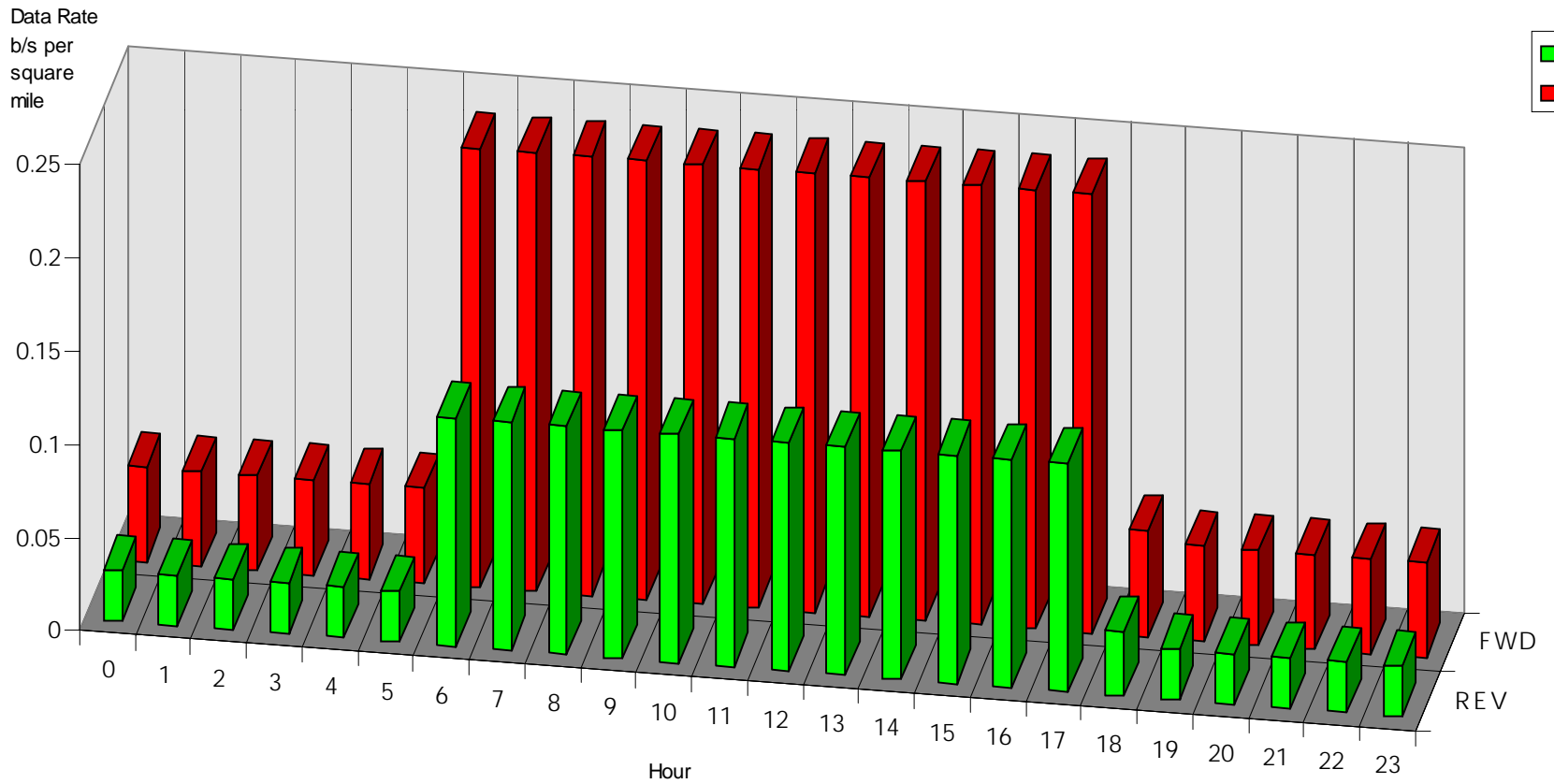


Figure 6.2-16 Data Loading by Service - Forward, 2012, Urbansville.

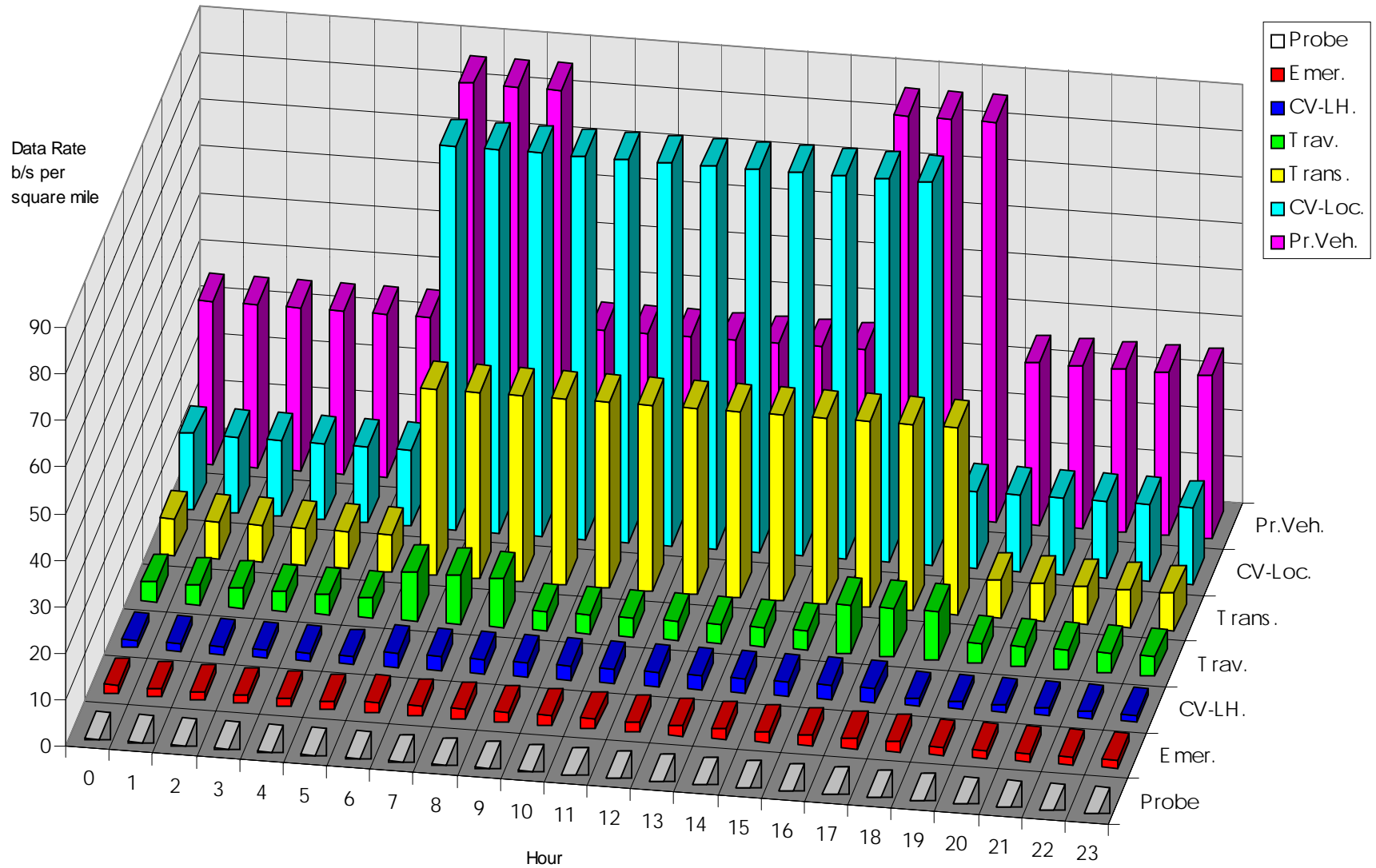


Figure 6.2-17 Data Loading by Service - Reverse, 2012, Urbansville

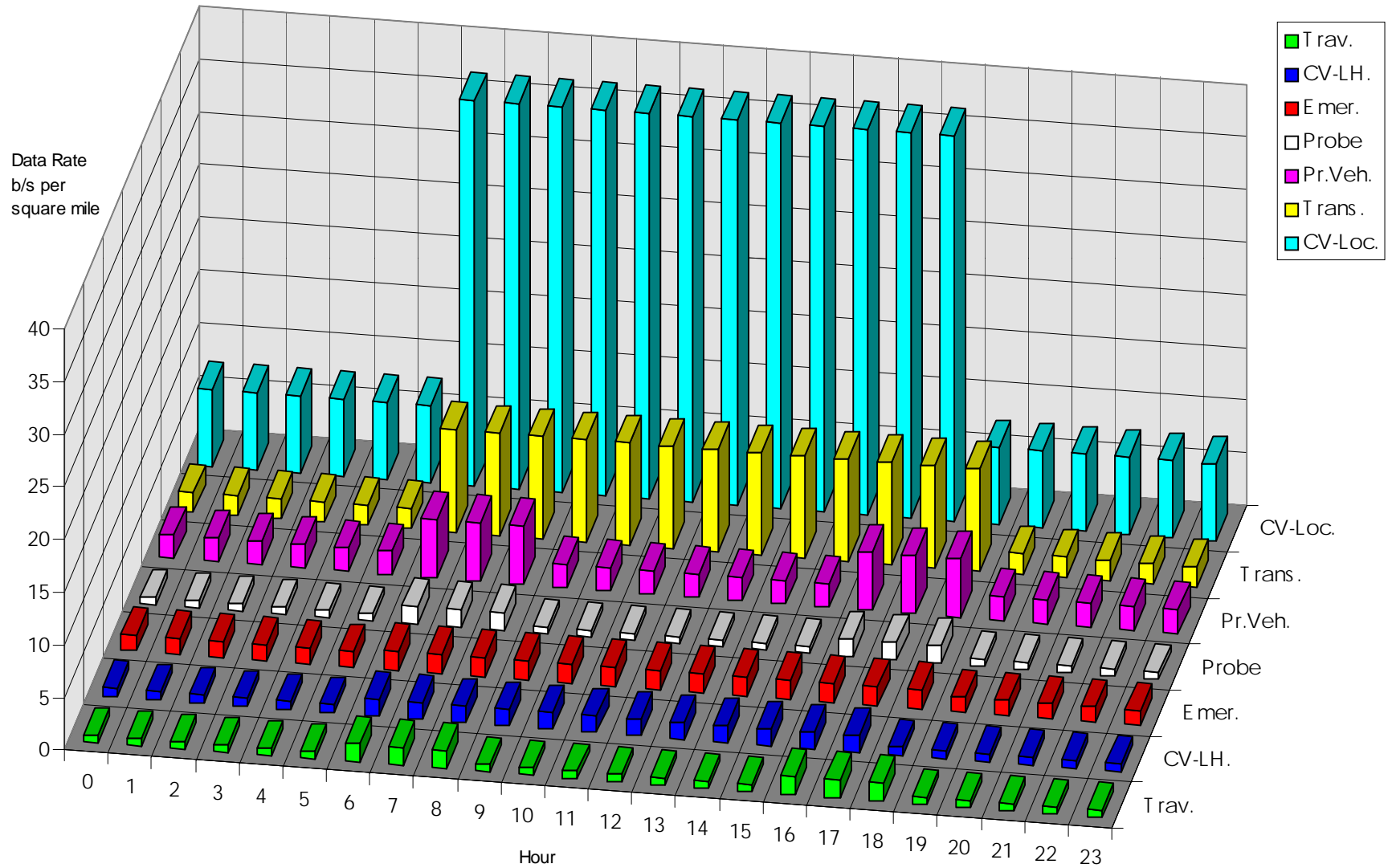


Figure 6.2.18 Total Data Loading, 2012, Urbansville.

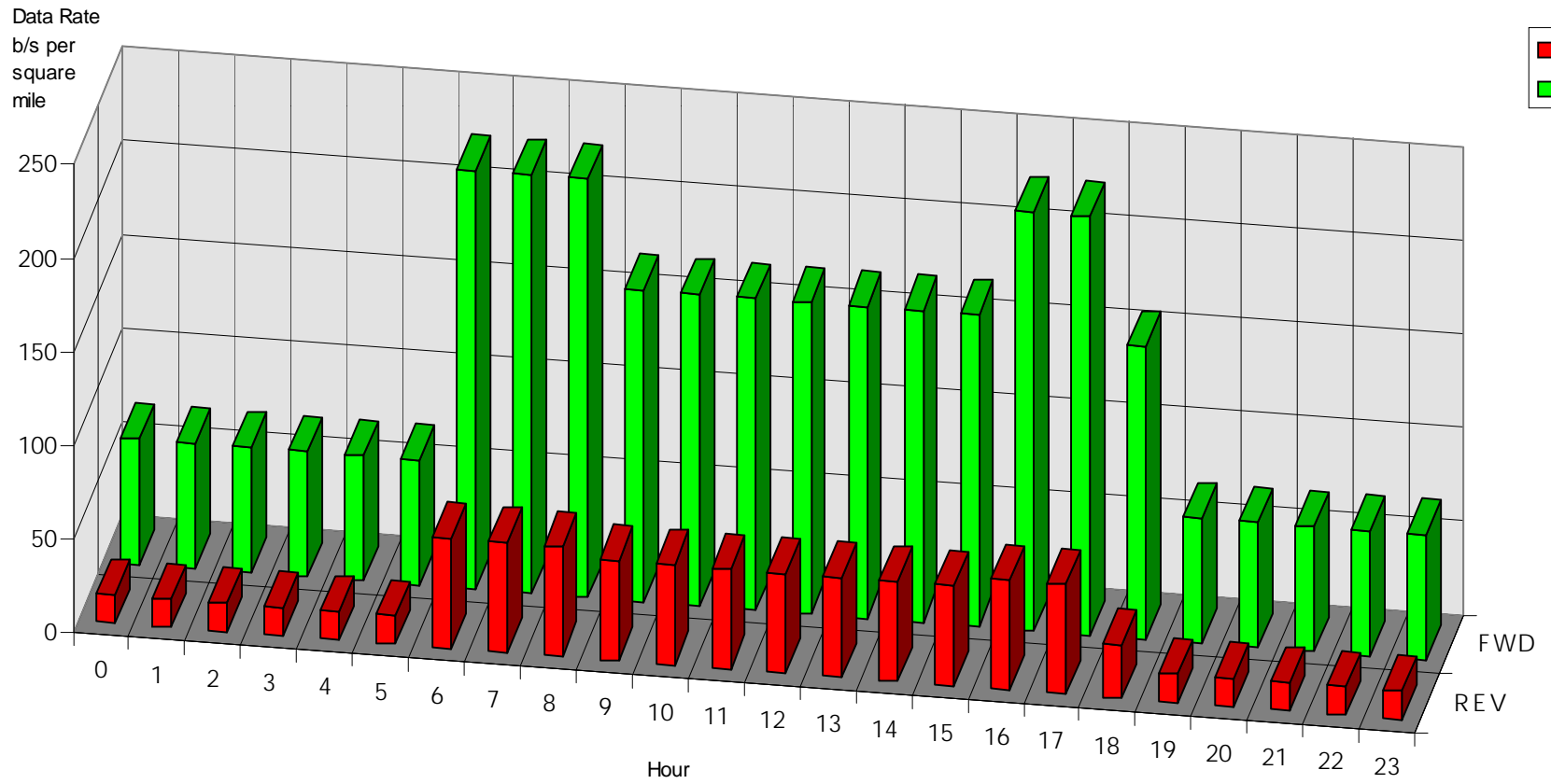


Figure 6.2-19 Data Loading by Service - Forward, 2012, Thruville.

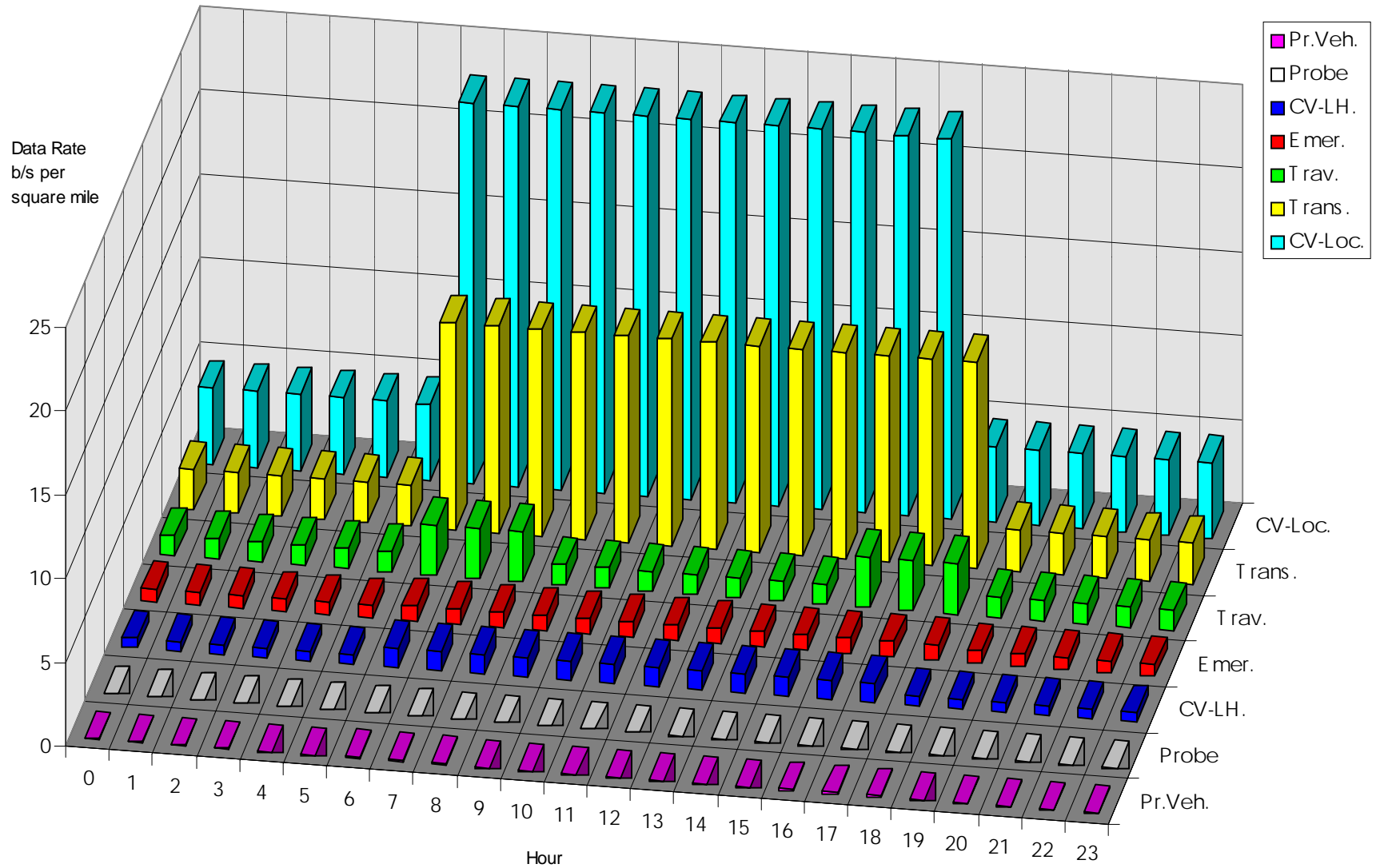


Figure 6.2-20 Data Loading by Service - Reverse, 2012, Thruville.

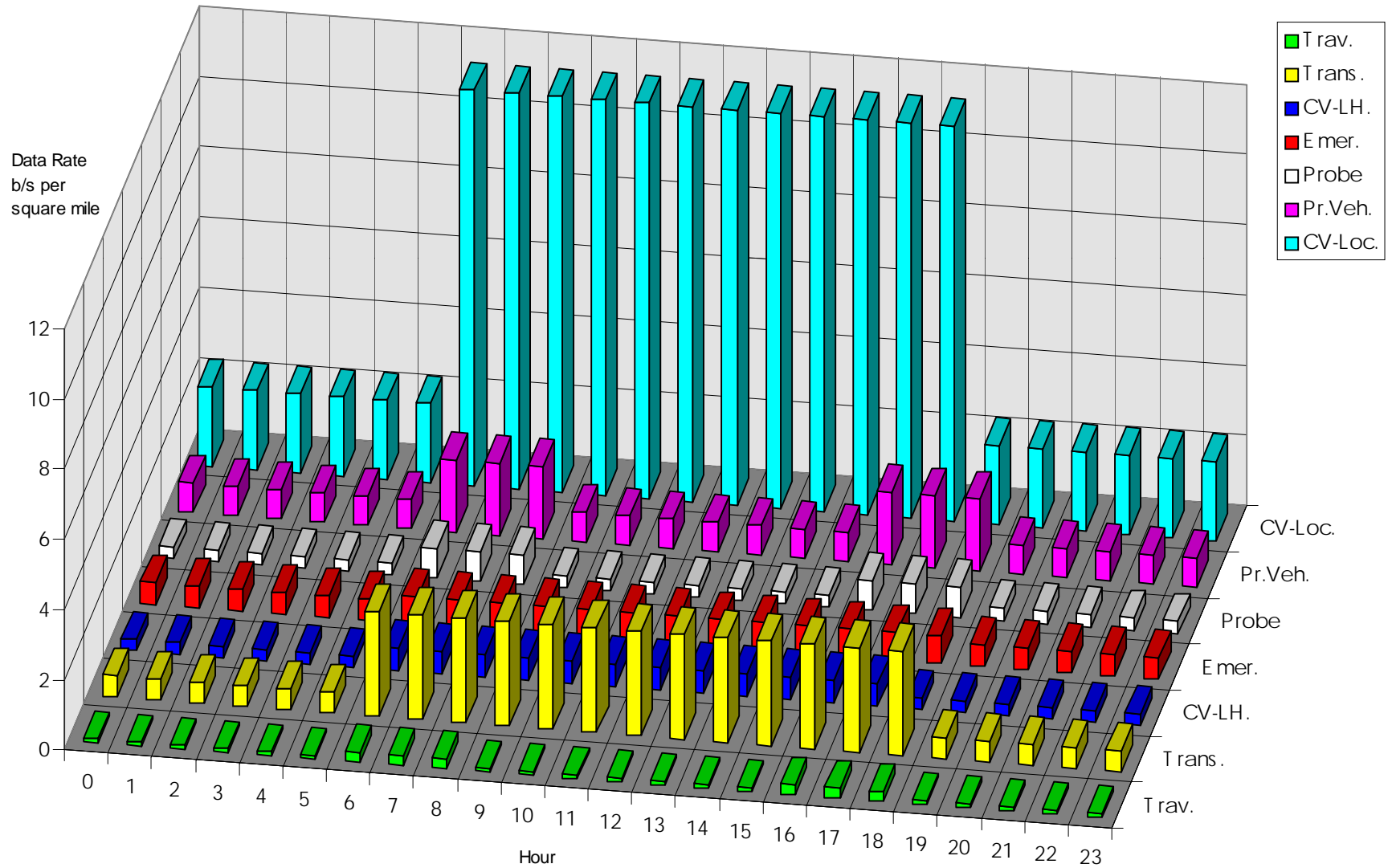


Figure 6.2-21 Total Data Loading, 2012, Thruville

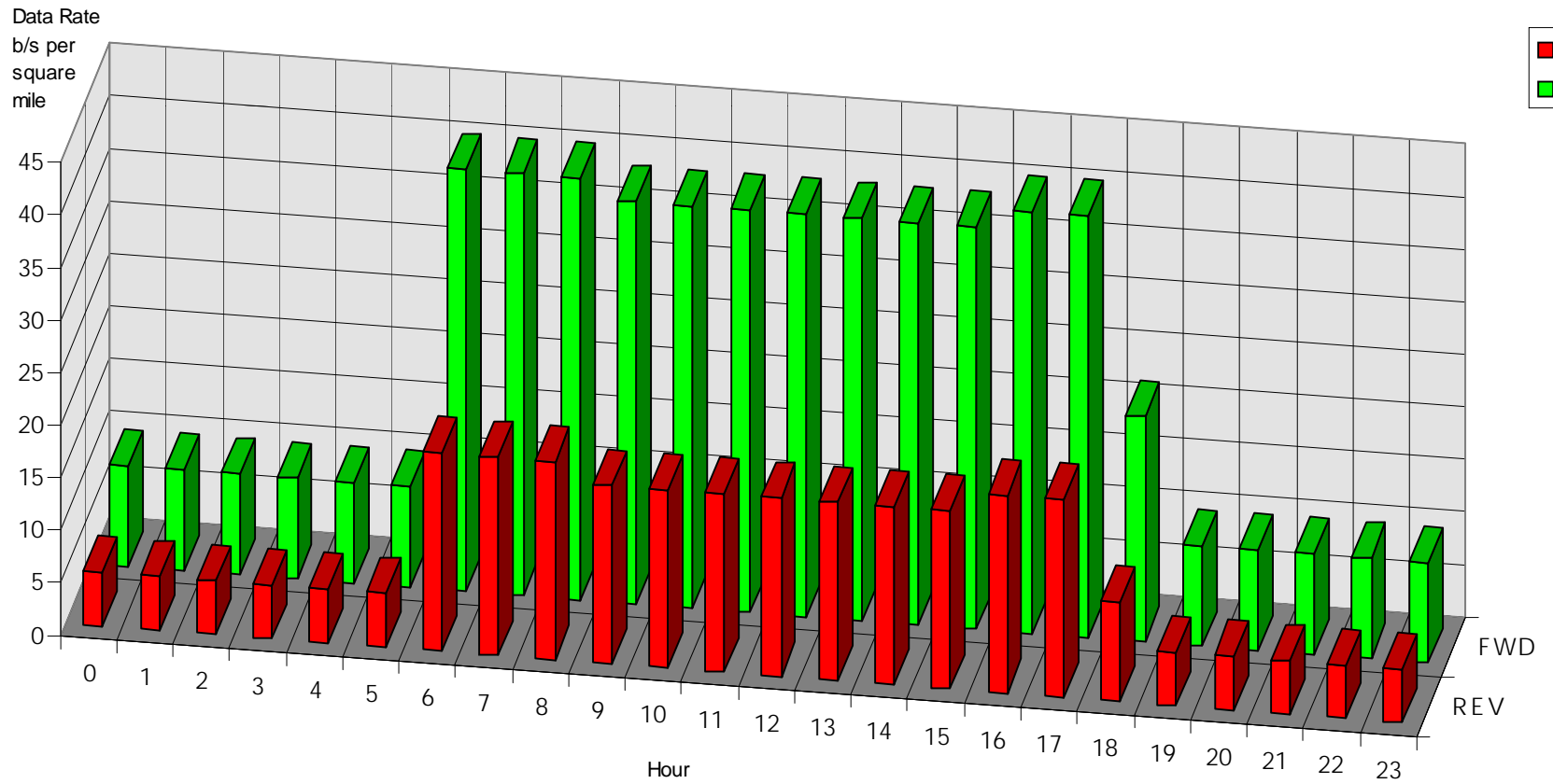


Figure 6.2-22 Data Loading by Service - Forward, 2012, Mountainville.

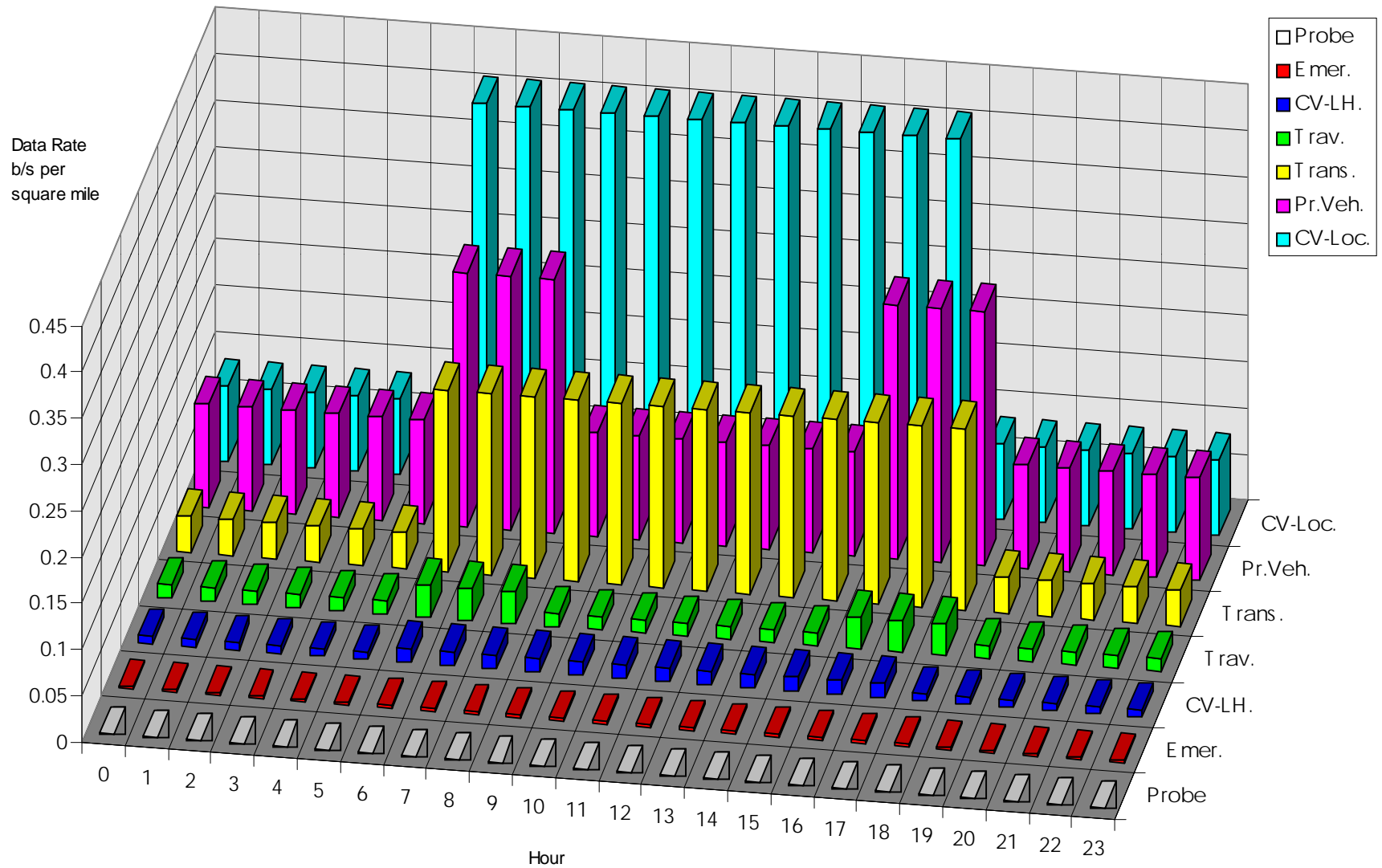




Figure 6.2-23 Data Loading by Service - Reverse, 2012, Mountainville.

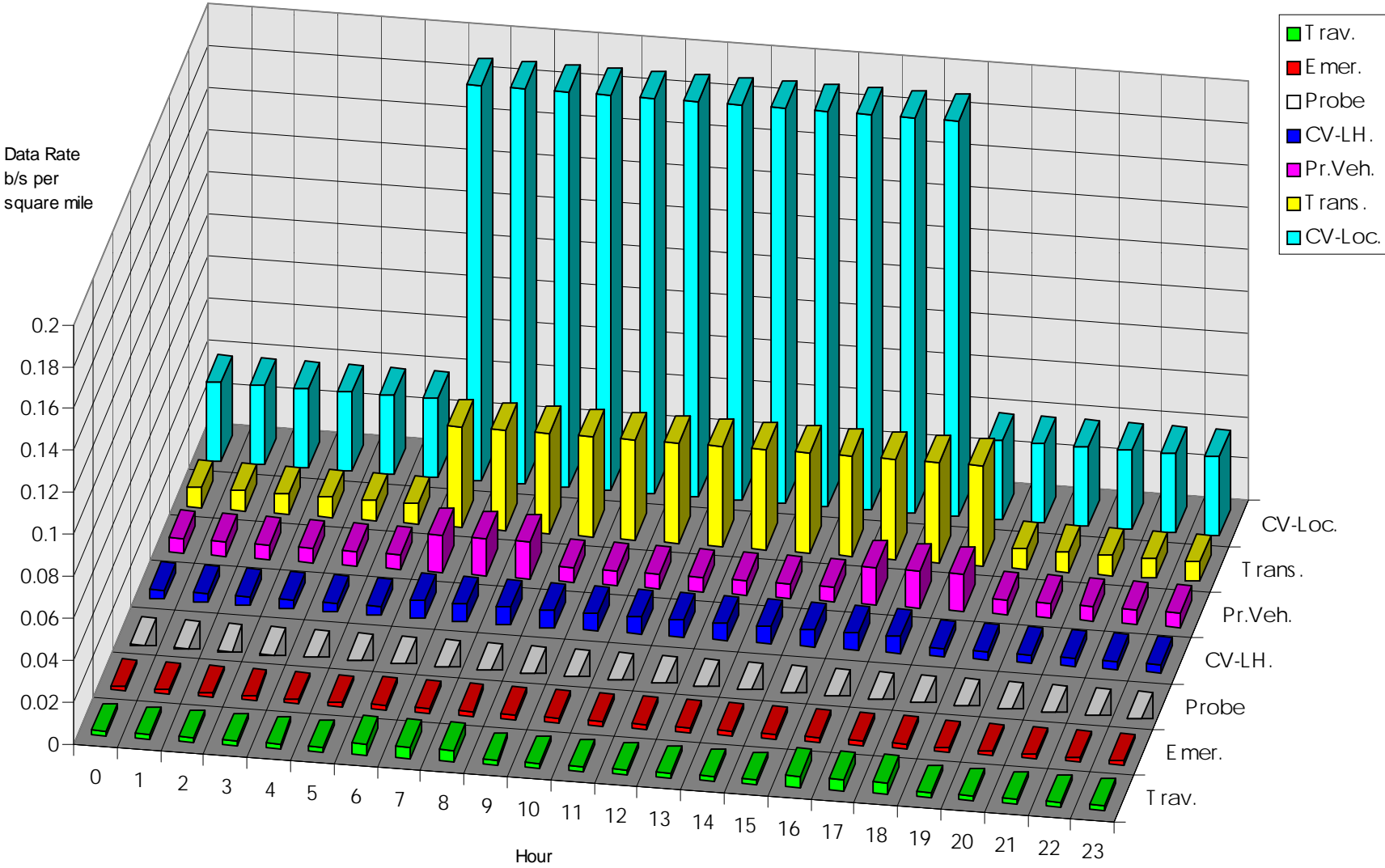
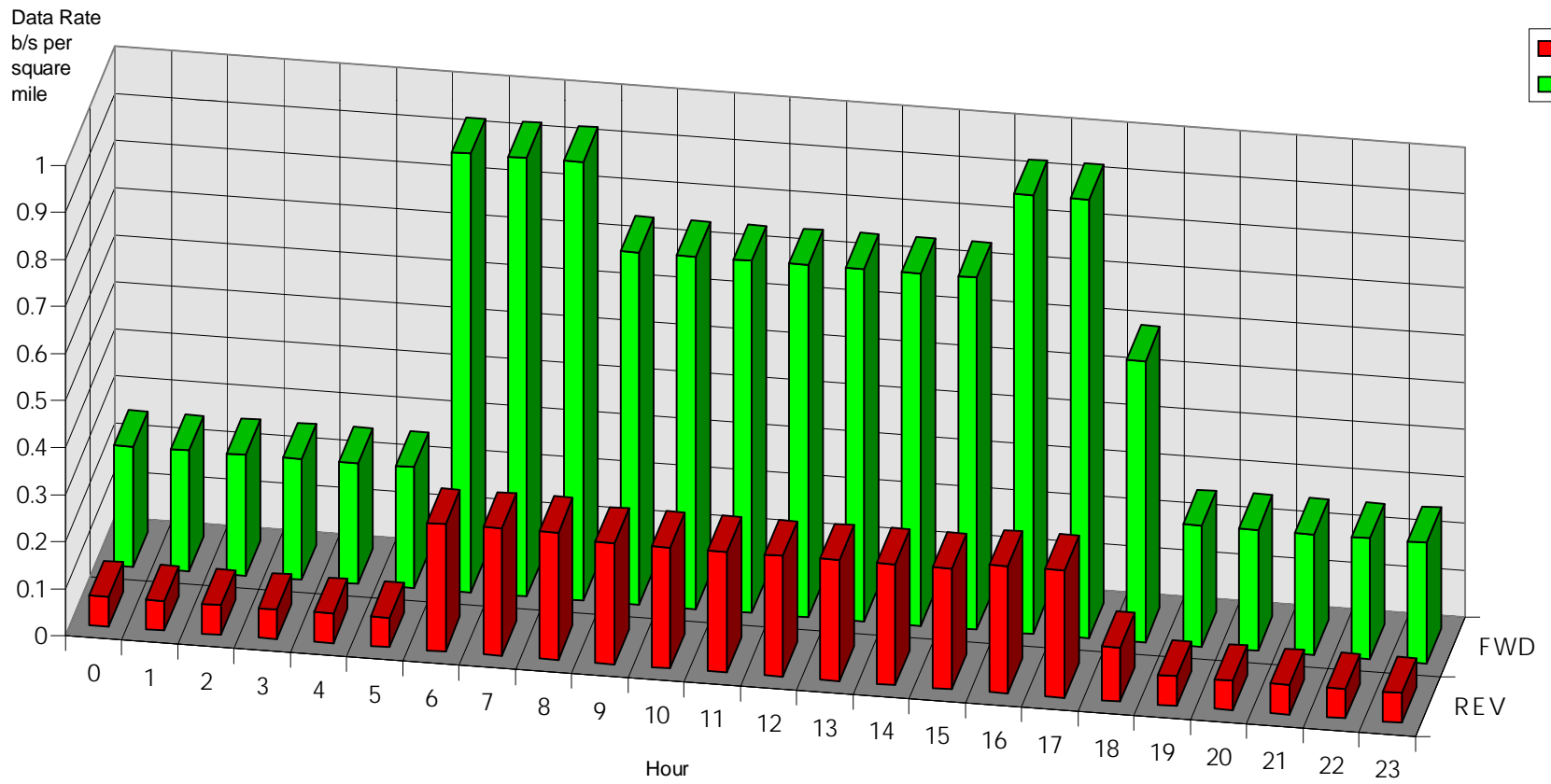


Figure 6.2-24 Total Data Loading, 2012, Mountainville.



**Table 6.2-1 Summary of Data Loading Results**

Units are in bits per second per square mile.  
 No ITS deployment is assumed for Mountainville in 1997.

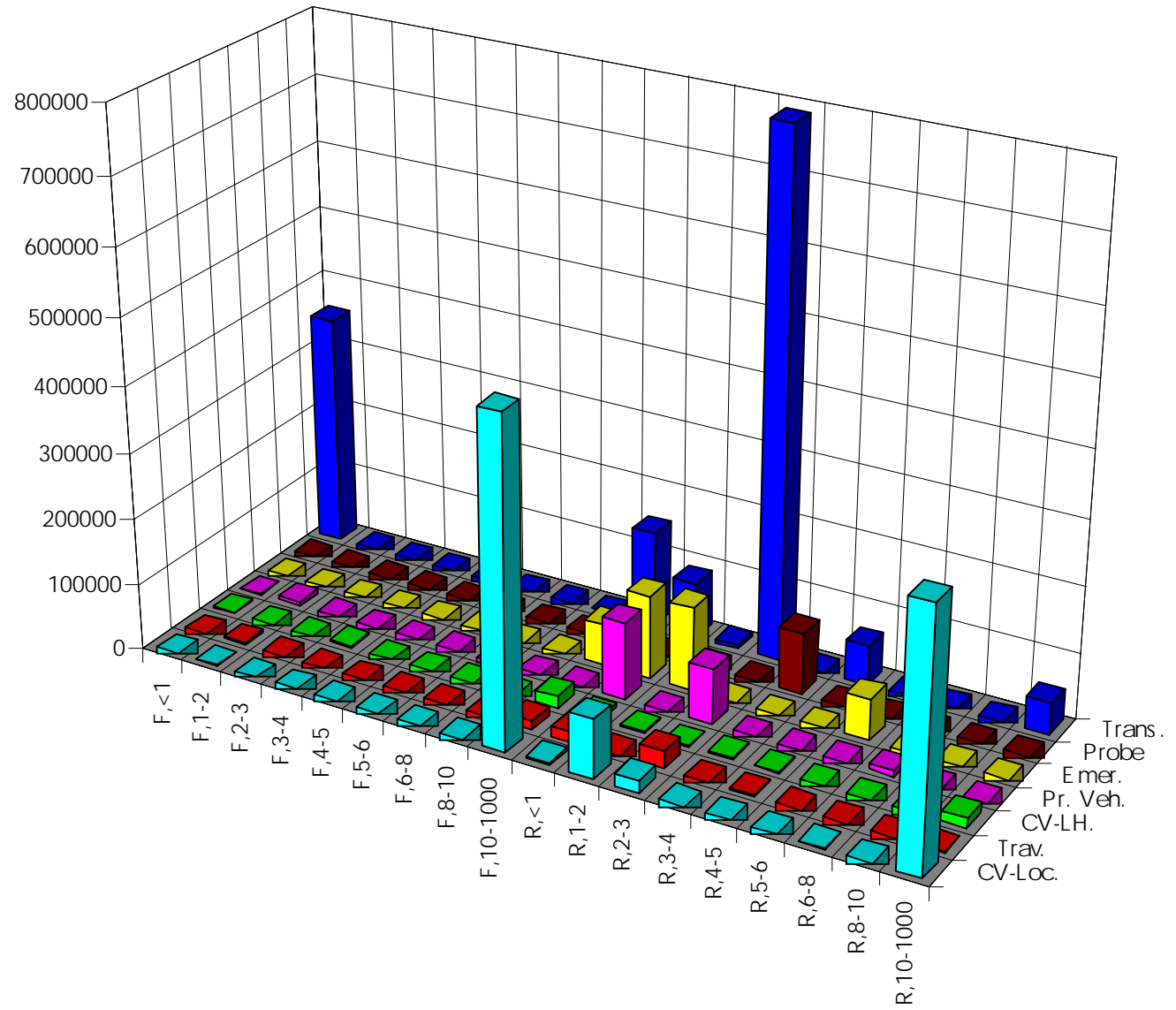
Year	Region	Direc.	Peak/Off-Peak	Pr.Veh.	Trav.	CV-Loc.	CV-LH.	Trans.	Emer.	Probe	TOTAL
1997	Urbansville	Fwd.	Peak per sq. mile:	0.00011	0.001	17.0426	0.61086	18.852	0.8055	0	37.312
1997	Urbansville	Fwd.	Off-Pk. per sq. mile:	4.6E-05	0.0004	3.40851	0.30543	3.7705	0.6444	0	8.1293
1997	Urbansville	Rev.	Peak per sq. mile:	0.13586	0.0153	8.40969	0.30144	1.8146	0.6722	1.676	13.025
1997	Urbansville	Rev.	Off-Pk. per sq. mile:	0.05529	0.0062	1.68194	0.15072	0.3629	0.5377	0.682	3.4768
1997	Thruville	Fwd.	Peak per sq. mile:	0	0	6.08559	0.2901	6.7306	0.3857	0	13.492
1997	Thruville	Fwd.	Off-Pk. per sq. mile:	0	0	1.21712	0.14505	1.3461	0.3086	0	3.0168
1997	Thruville	Rev.	Peak per sq. mile:	0	0	2.99933	0.14247	0.6479	0.3219	0.848	4.9598
1997	Thruville	Rev.	Off-Pk. per sq. mile:	0	0	0.59987	0.07123	0.1296	0.2575	0.345	1.4034
2002	Urbansville	Fwd.	Peak per sq. mile:	34.7122	2.0606	41.1999	1.55927	32.765	1.7521	0	114.05
2002	Urbansville	Fwd.	Off-Pk. per sq. mile:	14.1278	0.8387	8.23998	0.77963	6.553	1.4017	0	31.941
2002	Urbansville	Rev.	Peak per sq. mile:	1.96875	0.5357	18.6967	0.79403	7.9048	1.4732	1.676	33.049
2002	Urbansville	Rev.	Off-Pk. per sq. mile:	0.80128	0.218	3.73934	0.39701	1.581	1.1786	0.682	8.5972
2002	Thruville	Fwd.	Peak per sq. mile:	0.02433	0.48	12.8178	0.64325	11.136	0.8377	0	25.939
2002	Thruville	Fwd.	Off-Pk. per sq. mile:	0.0099	0.1954	2.56356	0.32162	2.2272	0.6702	0	5.9879
2002	Thruville	Rev.	Peak per sq. mile:	0.7944	0.0954	6.35185	0.35812	2.6867	0.7044	0.848	11.839
2002	Thruville	Rev.	Off-Pk. per sq. mile:	0.32332	0.0388	1.27037	0.17906	0.5373	0.5635	0.345	3.2577
2002	Mountainville	Fwd.	Peak per sq. mile:	4.1E-06	4E-08	0.21779	0.00823	0.0071	0.0025	0	0.2356
2002	Mountainville	Fwd.	Off-Pk. per sq. mile:	1.7E-06	2E-08	0.04356	0.00412	0.0014	0.002	0	0.0511
2002	Mountainville	Rev.	Peak per sq. mile:	6.5E-05	5E-07	0.10728	0.00452	0.0086	0.0021	0	0.1226
2002	Mountainville	Rev.	Off-Pk. per sq. mile:	2.7E-05	2E-07	0.02146	0.00226	0.0017	0.0017	0	0.0272
2012	Urbansville	Fwd.	Peak per sq. mile:	85.7982	10.484	82.056	3.1208	39.951	2.1606	0	223.57
2012	Urbansville	Fwd.	Off-Pk. per sq. mile:	34.9199	4.2668	16.4112	1.5604	7.9901	1.7285	0	66.877
2012	Urbansville	Rev.	Peak per sq. mile:	5.52382	1.7617	36.5907	1.57015	9.6664	1.8167	1.676	58.605
2012	Urbansville	Rev.	Off-Pk. per sq. mile:	2.24819	0.717	7.31814	0.78508	1.9333	1.4534	0.682	15.137
2012	Thruville	Fwd.	Peak per sq. mile:	0.11331	3.0041	22.6488	1.14186	12.298	0.9255	0	40.132
2012	Thruville	Fwd.	Off-Pk. per sq. mile:	0.04612	1.2227	4.52976	0.57093	2.4596	0.7404	0	9.5695
2012	Thruville	Rev.	Peak per sq. mile:	2.04407	0.2819	11.2614	0.64279	2.9756	0.7782	0.848	18.832
2012	Thruville	Rev.	Off-Pk. per sq. mile:	0.83194	0.1147	2.25227	0.3214	0.5951	0.6226	0.345	5.0833
2012	Mountainville	Fwd.	Peak per sq. mile:	0.27402	0.0344	0.40793	0.0156	0.1966	0.0029	0	0.9315
2012	Mountainville	Fwd.	Off-Pk. per sq. mile:	0.11153	0.014	0.08159	0.0078	0.0393	0.0023	0	0.2566
2012	Mountainville	Rev.	Peak per sq. mile:	0.01764	0.0058	0.18869	0.00834	0.0476	0.0024	0	0.2705
2012	Mountainville	Rev.	Off-Pk. per sq. mile:	0.00718	0.0024	0.03774	0.00417	0.0095	0.0019	0	0.0629

### ***6.2.1.1 Histogram of Message Size Distribution***

A histogram of the message size distribution for two-way wide area wireless links was prepared for the peak period for Urbansville for the 2002 time frame. The histogram is shown in Figure 6.2-25. The messages were sorted by size into bins of generally 100 bits wide, for the forward and reverse directions. The X axis shows the message size bins in units of hundreds of bits, where the “F” prefix is for the forward direction, and the “R” prefix is for the reverse direction. The Y axis shows the number of messages in that message size bin for the Urbansville region in the 2002 time frame.

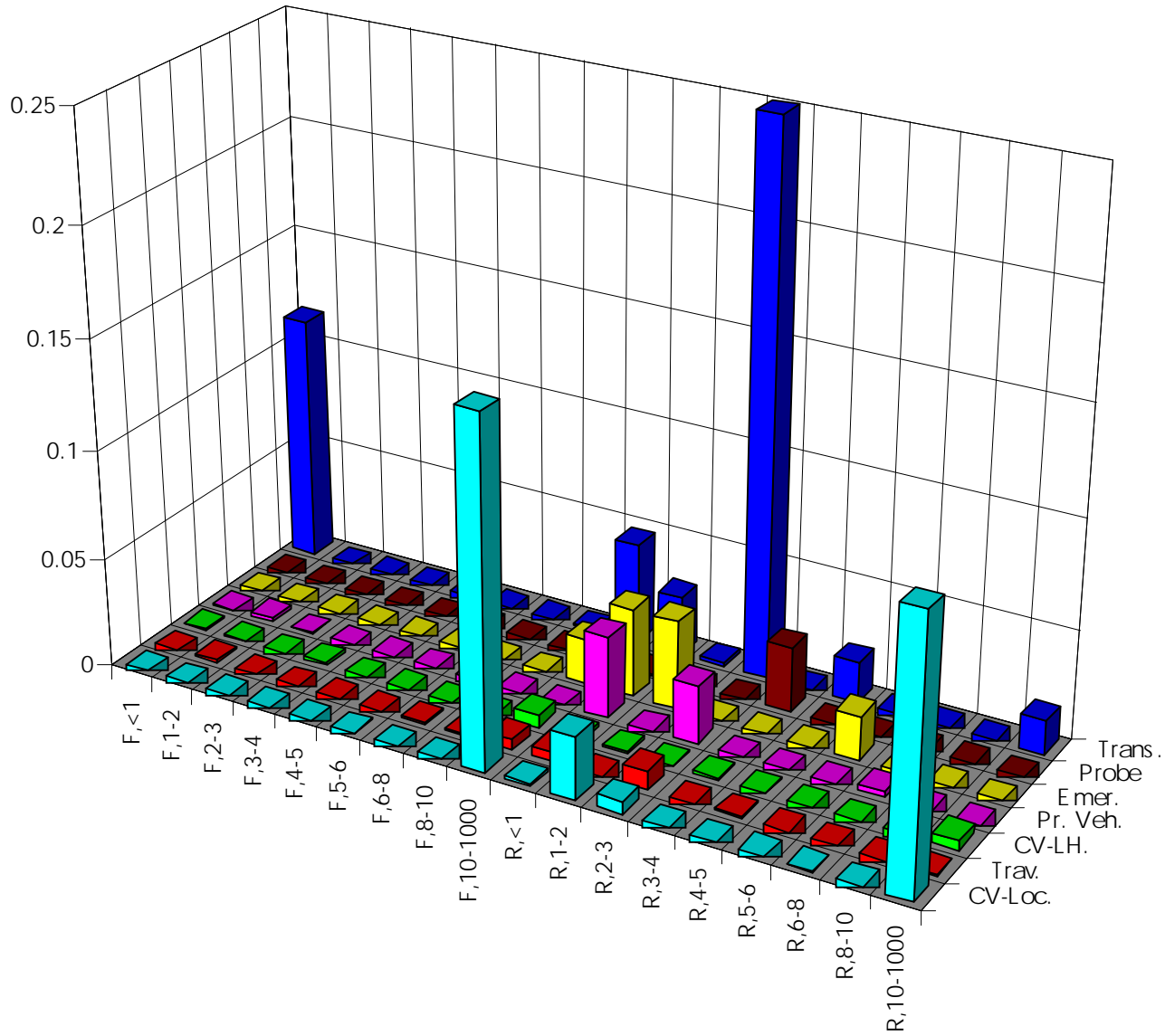
In order to provide a generalized result that can be applied to any urban region for the 2002 time frame, the histogram was calculated on a per-population basis. This histogram can then be used to calculate the distribution of messages for another urban region by multiplying the results by the population of the region to be studied. Figure 6.2-26 shows the per-population histogram.

**Figure 6.2-25 Distribution of Messages for Urbansville, 2002, Peak Period**



Note:  
 Y-Axis = Number of messages in peak period;  
 X-Axis = Message (in hundreds of bits);  
 F=Forward Direction;  
 R=Reverse Direction

Figure 6.2-26 Distribution of Messages per Population, Urban Area, 2002, Peak Period



## 6.2.2 Broadcast Data Loads

Table 6.2-2 lists a set of typical ITS services that are candidates for one-way wireless communication. These include: traffic information, traveler information, and transit services. For each service, the table presents: (1) message name, (2) message length in bits, (3) typical number of required links per geographical area, (4) average update frequency (e.g. traffic data every 10 minutes), (5) the effective information rate, which is calculated using the following expression:

$$\begin{aligned} \text{Information rate (bits/sec)} = & [\text{Message length (bits/message)}] \\ & * [\text{num of traffic links (applicable to the message)}] \\ & * [\text{update rate (messages/sec)}] \end{aligned}$$

Each message consists of a number of sub-flows. For example, the traffic\_data\_for\_portables is composed of:

- tmc\_identity
- traffic\_data\_for\_media
- traveler\_identity, current\_data\_for\_media
- long\_term\_data\_for\_media
- predictive\_model\_data\_for\_media
- long\_term\_data\_for\_media
- wide\_area\_pollution\_data
- pollution\_state\_area\_collection
- current\_ozone\_pollution

Table 6.2-2 presents the size of the messages for a complete set of flows. The update frequency can be designed so that a full set of data flows for a message is broadcast at a low frequency (e.g., once every 10 minutes) and partial changes are broadcast at a higher frequency (e.g., once every minute).

Table 6.2-2 also presents the aggregate information rate. This is the effective information rate that the communication system must handle to provide these services in a geographical area. For these services the aggregate information rate is about 5651 bps.

**Table 6.2-2 Candidate Messages for One Way Wireless Communication**

<b>Message Name</b>	<b>Size (bits)</b>	<b>No. of Links</b>	<b>Update Freq. (min.)</b>	<b>Data Rate (bps)</b>
<b>Traffic Information Services</b>				
traffic_data_for_portables	819314	1	10	1,366
<b>Aggregate Information Rate (bps)</b>				<b>1,366</b>
<b>Transit Services</b>				
transit_deviations_for_portables	3560	1	15	4
traffic_data_for_kiosks	83874939	1	1500	932
transit_deviations_for_kiosks	357648	1	10	596
transit_services_for_portables	2512	1	10	4
<b>Aggregate Information Rate (bps)</b>				<b>1,536</b>
<b>Traveler Information Services</b>				
traveler_yellow_pages_data	970	50	10	81
advisory_data	6128	50	5	1,021
broadcast_data	10992	64	10	1,172
link_and_queue_data	400616	4	60	445
yellow_pages_advisory_data	10784	10	60	30
<b>Aggregate Information Rate (bps)</b>				<b>2,750</b>
<b>Total Broadcast Information Rate (bps)</b>				<b>5,651</b>

### 6.2.3 Short Range DSRC Data Loads

An analysis for DSRC systems when applied to a wide area setting, including data loads, is contained in Appendix G. The conclusion from there (and elsewhere) is that beacon systems are not appropriate as a substitute for wide area commercial services for wide area ITS applications (e.g., route guidance). DSRC is only recommended for those specific applications that require an intimate physical interaction between the vehicle and the roadside infrastructure, such as in toll collection, commercial vehicle check, roadside safety inspection and the like (see Chapter 3). In all of these cases, because of the limited coverage of a beacon system and its fairly high data rate, data loading from a capacity standpoint is not an issue.

### 6.3 Wireline Data Loads

Wireline data loads are less critical than wireless because the current capabilities of the wireline infrastructure are simply enormous. Typically, the choice of medium (fiber, coaxial, etc.) is dictated by the desires and budgetary constraints of the jurisdictions. In any event, for



completeness, wireline data loads based on the subsystem, data flow, and market package definitions have been calculated.

Data loads were calculated for all of the links between subsystems for the wireline (w) interface. Since the frequency of message use on these links is not directly related to usage by individual vehicle end users (for instance, a dataflow performing a database update that is transferring data on intersection traffic has a size or frequency of use related directly to the number of intersections in the region), the numerous parameters that enter into this analysis came from those used in the teamwork model of the logical architecture and used in sizing there as well. These parameters are all for the 2012 Urbansville scenario, proving a worst-case analysis.

Table 6.3-1 lists the independent parameters assumed in the analysis; Table 6.3-2 shows the derivation of the dependent parameters that are based on the independent parameters.

**Table 6.3-1 Independent Parameters Used in the Wireline Data Loading**

Name	Description	Urban 20 Year
ADJACENT_TMS	The average number of adjacent or cooperating Traffic management centers that a TMS within the ITS area under study will communicate with on a regular basis	5
AHS_MILES	The total number of ITS roadway miles being operated under some form of AHS system.	10
AHS_SEGMENT_LENGTH	The average length on an AHS segment.	3
AHS_TRIPS_per_DAY	The assumed average number of trips each AHS capable vehicle will make each day.	2
AHS_VEH_per_PLATOON	The average size of an AHS platoon, in vehicles.	6
AIR_RATE	The proportion of ITS traveler interactions that involve AIR as an alternative transportation mode..	0.1
AUTOINFRA	The assumed which all ITS users prefer autonomous versus infrastructure based route guidance.	0.25
BROADCAST_ITEMS	The number of broadcast data items typically contained in a specific ITS advisory broadcast.	6
COM_VEHS	The total number of commercial vehicles operable within the ITS area under study.	7802
CONTROLLERS_PER_HIGHWAY_CORRIDOR	The average number of traffic controllers per highway corridor within the jurisdiction being studied.	2
CONTROLLERS_PER_ROAD_CORRIDOR	The average number of traffic controllers per road corridor within the jurisdiction being studied.	2
CVI_RATE	The rate at which an average Commercial Vehicle Inspector actually performs inspections, expressed as Inspections per second. The numbers shown represent an average inspection time of approximately 30 minutes, to include preparation, rest periods.	0.0006
CVO_FAC	The total number of Commercial Vehicle Roadside facilities that are operating in the ITS area under study.	1
CVO_FAULT_RATE	The assumed rate at which commercial vehicles fail roadside inspections for all reasons to include safety, permits, driver credentials etc.	0.01
CVO_MAN	The total number of Commercial Vehicle Fleet Managers who can have simultaneous direct access to ITS at any one time. This will be less than the actual number of such Managers employed within the ITS area if they are working shifts.	20
CVO_VEHS	The total number of commercial vehicles operable within the ITS area under study.	7802
EP_MONITOR_DENSITY	The expected number of environmental pollution monitoring points (i.e. roadside transponders) normalized to intersections.	2

**Table 6.3-1 Independent Parameters Used in the Wireline Data Loading**

Name	Description	Urban 20 Year
ERMS_CALL_RATE	The daily rate at which EMS departments receive calls as a function of total population. The numbers for the Urban environment are based on a study of fire department EMS calls in 1994, reported by the Journal of Emergency Medical Services.	0.00034
ERMS_ROUTE_LENGTH	The average length of an emergency vehicle route, in miles.	5
ERMS_VEHS	The total number of emergency services vehicles available for operation in the ITS area under study. This takes no account of whether the vehicles are active or not.	5981
EVENT_RATE	The daily rate at which special events are scheduled which require ITS notifications.	4
FERRY_RATE	The proportion of ITS traveler interactions that involve FERRY operations as an alternative transportation mode..	0.001
HIGHWAY_CORRIDORS	The total number of primary highway traffic corridors under ITS strategic planning and control within the jurisdiction being studied.	18
HIGHWAY_CROSSINGS	The total number of controlled or monitored multi-modal crossings of roads within the ITS environment under study. Based on data available for "typical" urban, interurban and rural areas.	2000
HIGHWAY_MILES	Total freeway (limited access ) mileage in the ITS area under study.	225
HIGHWAY_PLAN_SEQUENCE S	The number of distinct planned sequences used for highway sign activation..	30
HIGHWAY_SIGN_PLANS	The number of distinct plans used for highway sign activation..	30
HIGHWAY_SIGN_SEQUENCE S	The number of distinct sequences used for highway sign activation..	30
IMAGE_LARGE	A large (or high resolution) image, typically used for automated surveillance (as opposed to human visual) processes. Roughly equivalent to a 256 color (or gray scale) image of 1024 X 1024 picture elements (pels).	1048576
IMAGE_SMALL	A small (or low resolution) image, typically used for visual identification (as opposed to automatic) purposes. Roughly equivalent to a 256 color (or gray scale) image of 640 X 480 picture elements (pels).	307200
INCIDENT_RATE	An assumed average incidents per vehicle in a day, normalized to general vehicle population (VEHS).	0.0001
INTERSECTIONS	The total number of controlled or monitored intersections within the ITS environment under study. Based on data available for "typical" urban, interurban and rural areas.	2560
INTERSECTIONS_PER_CORRIDOR	The average number of roadway intersections per corridor within the jurisdiction being studied.	200
JPEG	Images are assumed to be compressed for the purposes of estimating data flow sizes. Still images are assumed to be compressed using the Joint Photographic Experts Group (JPEG) methodology.	0.03
KIOSKS_PER_TRANSIT_STOP	An assumed density of kiosk facilities based on the number of transit stops in the ITS area under study.	0.5
LANE_FLOW_RATE	Average traffic flow rate (Vehicles/second) on a single traffic lane. Based on a 24 hour period, this value should be adjusted as required to quantify time-of-day and incident specifics.	0.04
LANES_PER_DIRECTION	The average number of lanes, in each direction, at an average intersection.	3
LINK_LENGTH	The average length, in miles, of a navigable route link, for the ITS area under study. This parameter is quantified for roadway links. Pedestrian travelers may require shorter links.	1
LINK_STOPS	The average number of stops in an average link.	1

**Table 6.3-1 Independent Parameters Used in the Wireline Data Loading**

Name	Description	Urban 20 Year
LINKS_PER_INCIDENT	The average number of roadway links affected by an incident.	10
LOCAL_DATA	The typical number of data items containing advisory data that will be relevant to the local area surrounding a particular vehicle. This parameter is used to "filter" the advisory data list for data loading analysis..	3
MAX_AHS_SEGS	The maximum allowable number of segments into which a valid ahs route may be divided. This is an arbitrary assumption and is highly dependent on system design constraints.	10
MAX_ENF_AGENCIES	The maximum number of enforcement agencies with which an ITS communicates.	5
MAX_HIGHWAY_SEGS	The maximum allowable number of segments into which a valid freeway route may be divided. This is an arbitrary assumption and is highly dependent on system design constraints.	10
MAX_ROAD_SEGS	The maximum allowable number of segments into which a valid route over surface streets may be divided. This is an arbitrary assumption and is highly dependent on system design constraints.	100
MAX_SEG_WPS	The maximum allowable number of waypoints which a valid segment may utilize. This is an arbitrary assumption and is highly dependent on system design constraints.	10
MAX_STRATEGIES	The maximum number of traffic management strategies that can be specified for use in a single day.	400
MEDIA_OPS	The number of Media Operators who can have simultaneous direct access to the TMC at any one time. This will be less than the actual number of Media Operators who actually access the ITS if they are working shifts.	5
MODE_CHANGES	The average number of mode changes in an average traveler route.	1
MOV_BRIDGES	The total number of movable bridges within the ITS area under study. Based on available data for typical urban, interurban and rural areas.	4
MP	Market penetration assumption for ITS capabilities. It is used where a specific market penetration (e.g. MP_CVO) is not available or appropriate.	0.5
MP_CVO	Market penetration assumption for CVO operations. Expressed as a percentage of the total commercial fleet that will invest in equipment and/or services to utilize ITS functions.	0.75
MPAHS	The assumed AHS Market Penetration, i.e. the percentage of vehicles that are equipped to operate on AHS lanes.	0.001
MPCV	The assumed Commercial Vehicle Market Penetration, i.e. the percentage of commercial vehicles that are equipped to utilize ITS functions.	0.75
MPEG	Images are assumed to be compressed for the purposes of estimating data flow sizes. Full motion images are assumed to be compressed using the Motion Pictures Experts Group (MPEG) methodology. This parameter establishes the ratio assumed in this analysis.	0.01
MPKIOSK	The market penetration of ITS Travelers using Kiosks.	0.75
MPPDA	The market penetration of ITS Travelers using PDA devices.	0.1
MPPTT	The assumed Paratransit Traveler Market Penetration, i.e. the percentage of travelers that utilize paratransit operations.	0.03
MPPTV	The assumed Paratransit Vehicle Market Penetration, i.e. the percentage of vehicles providing flexible transit services that are equipped to utilize ITS functions.	1
MPPV	The assumed Private Vehicle Market Penetration, i.e. the percentage of private vehicles that are equipped to utilize ITS functions.	0.1

**Table 6.3-1 Independent Parameters Used in the Wireline Data Loading**

Name	Description	Urban 20 Year
MPTR	The assumed Traveler Market Penetration, i.e. the percentage of travelers that will utilize ITS functions.	0.1
MPTU	The assumed Transit User Market Penetration, i.e. the percentage of transit users that utilize ITS functions.	0.15
MPTV	The assumed Transit Vehicle Market Penetration, i.e. the percentage of transit vehicles that are equipped to utilize ITS functions.	1
NUM_ROUTES	The number of individual routes included in an average trip plan.	6
NUM_SEGS	The number of individual route segments included in an average route.	10
NUM_TRANSIT_ROUTES	The average total number of transit routes included within the ITS environment being analyzed. Does not include transit routes of "other TMS" environments. This is a assumption of a "typical" value derived from demographic data of U.S.	20
PARATRANS_MP	Market penetration for paratransit operations. Expressed as a percentage of the total population that will use para-transit facilities.	0.03
PARKING_LANES	The maximum number of parking lot payment lanes that are operating at a single parking lot in the ITS area under study. It is assumed that these lanes will only be used by vehicles that are equipped to utilize ITS functions.	2
PARKING_LOTS_PER_PROVIDER	The average total number of parking lots that are being operated by a single parking lot service provider in the ITS area under study.	4
PARKING_PROVIDER_RATE	Number of independent parking providers, normalized to general vehicle population (VEHS).	0.0002
PARKING_SPACE_RATE	Number of independent parking spaces, normalized to general vehicle population (VEHS).	0.01
PEDESTRIANS	The total number of controlled or monitored pedestrian crossings that are not also intersections within the ITS environment under study. Based on data available for "typical" urban, interurban and rural areas.	100
POPULATION	The total population of the ITS environment under study.	3788627
PTRANSIT_VEHS	The total number of Paratransit vehicles operating within the ITS area under study. A Paratransit vehicle is one that is used to carry one or passengers on a non-scheduled transit service that may not follow a fixed route.	100
PVT_MP	The assumed Private Vehicle Market Penetration, i.e. the percentage of private vehicles that are equipped to utilize ITS functions.	0.1
PVT_VEHS	The total number of vehicles excluding commercial and transit vehicles, operable within the ITS area under study.	2273176
RAIL_RATE	The proportion of ITS traveler interactions that involve heavy or light RAIL as an alternative transportation mode..	0.01
RAMPS	The total number of controlled or monitored highway access ramps within the ITS environment under study. Based on data available for "typical" urban, interurban and rural areas.	400
ROAD_ADAPTIVE_PLANS	The maximum number of indicator adaptive data (adaptive plans) that are available from the Manage Traffic Function.	10
ROAD_CORRIDORS	The total number of primary road traffic corridors under ITS strategic planning and control within the jurisdiction being studied.	18
ROAD_CROSSINGS	The total number of controlled or monitored multi-modal crossings of roads within the ITS environment under study. Based on data available for "typical" urban, interurban and rural areas.	2000
ROAD_FIXED_PLANS	The maximum number of fixed time indicator control sequences (fixed time plans) that are available from the Manage Traffic Function.	30

**Table 6.3-1 Independent Parameters Used in the Wireline Data Loading**

Name	Description	Urban 20 Year
ROAD_MILES	The total mileage of ITS usable roads and streets (as distinct from highways) within the area under analysis.	1701
ROUTE_LENGTH	The average length (in miles) of the average route requested of, or provided by the ITS system under study.	15
TAG_DEFECT_RATE	The assumed average rate at which tags will be rejected by ITS equipment INCLUDING bad credit, stolen tags and system failures.	0.0001
TOLL_LANES	The maximum number of toll lanes that are operating at an average toll plaza in the ITS area under study. It is assumed that these lanes will only be used by vehicles that are equipped to utilize ITS functions.	2
TOLL_MILES	The total number of ITS roadway miles being operated under some form of toll system. Based on available data for typical urban, interurban and rural areas.	50
TOLL_PLAZAS	The total number of toll collection points within the ITS area under study. Based on available data for typical urban, interurban and rural areas.	10
TRAFFIC_COORDINATION_RULES	The number of road-freeway coordination rules that are available from the Manage Traffic Function.	10
TRAFFIC_OPS	The number of Traffic Operations Personnel who can have simultaneous direct access to the TMC at any one time. This will be less than the actual number of Traffic Operations Personnel employed at the TMC if they are working shifts.	10
TRANSIT_DRIVERS	The total number of transit drivers available to operate the transit vehicles within the ITS area under study.	200
TRANSIT_FLEETS	The total number of transit fleets operating in the ITS area under study. The fleets may be operating the same type of service, e.g. buses, or differing types, e.g. one for buses, another for light rail (trams).	3
TRANSIT_STOPS	The total number of transit stops on all transit routes within the ITS area under study. It is assumed that as a minimum, they are all capable of receiving and displaying data about the next services due to arrive at the stop.	400
TRANSIT_TECH_WR	The average number of transit vehicles that one transit maintenance technician can service in an hour.	1
TRANSIT_USAGE_RATE	Number of transit users, normalized to total population (POPULATION).	0.01527
TRANSIT_VEHS	The total number of transit vehicles available for operation within the ITS area under study. A transit vehicle is a special type of vehicle that is designed and equipped to carry a number of passengers on a scheduled route.	1788
TRANSIT_WAIT_TIME	The average waiting time between regularly scheduled transit vehicles.	5
TUNNELS	An arbitrary assumption about the number of tunnel segments being managed by the ITS system under study..	1
VEHICLE_SIGN_OUTPUT_DENSITY	The expected number of in-vehicle signage transmission points (i.e. roadside transponders) per intersection.	2
VIDEO_CAMS	The total number of video sources in operation within the ITS area under study. Video sources are assumed to represent a significant data communications load.	850
YP_GLOBAL_ITEMS	The typical number of items of "yellow pages" type of information that will be available from throughout the geographic and/or jurisdictional area served by the ITS under study.	15

**Table 6.3-1 Independent Parameters Used in the Wireline Data Loading**

Name	Description	Urban 20 Year
YP_LOCAL_ITEMS	The typical number of items of "yellow pages" type of information that will be available in the local area of a particular vehicle.	15

**Table 6.3-2 Dependent Parameters Used in the Wireline Data Loading Analysis**

Name	Description	Basis
ACT_ERMS_VEHS	The total number of emergency services vehicles that are active for any particular emergency call. This will be a proportion of the total number of emergency services vehicles (ERMS_VEHS).	= 0.1 * ERMS_VEHS
AHS_SAMPLE_RATE	An arbitrary sample rate constant used to facilitate data loading estimates for AHS operations.	= 1 / DAY
AHS_VEHS	The total number of vehicles that are utilizing AHS functions to obtain dynamic in-vehicle route guidance. Based on an assumed market penetration (MPAHS) and the general vehicle population.	= MPAHS * VEHS
AUTONOMOUS_TRAVS	The total number of travelers that are utilizing autonomous route guidance. Based on an assumed ratio (AUTOINFRA) and the number of guided travelers (ITS_GUIDED_TRAVS).	= AUTOINFRA * ITS_GUIDED_TRAVS
CONTROLLERS	The total number of intermodal crossing controllers in traffic corridors.	= HIGHWAY_CROSSING_CONTROLLERS + ROAD_CROSSING_CONTROLLERS
CORRIDORS	The total number of traffic corridors.	= HIGHWAY_CORRIDORS + ROAD_CORRIDORS
CROSSING_CONTROLLER S	The total number of intermodal crossing controllers in traffic corridors.	= HIGHWAY_CROSSING_CONTROLLERS + ROAD_CROSSING_CONTROLLERS
CROSSINGS	The total number of intermodal HIGHWAY_CROSSINGS and ROAD_CROSSINGS	= HIGHWAY_CROSSINGS + ROAD_CROSSINGS
CVC_SAMPLE_RATE	An arbitrary sample rate constant used to facilitate data loading estimates for CVC operations.	= 1 / DAY
CVO_DVR	The total number of Commercial Vehicle Drivers who also act as their own Fleet Managers. This will be a proportion of the number of Commercial Vehicles (CVO_VEHS). It is assumed that all of the vehicles belonging to these owner drivers will be equipped.	=0.5 * CVO_VEHS
CVO_FAC_PER_ROUTE	The average number of CVO facilities on a typical CVO route. Dependent on the assumed total number of facilities (CVO_FAC) and the relative number of segments in a typical route (NUM_SEGS/ROADWAY_SEGS).	= (NUM_SEGS / ROADWAY_SEGS) * CVO_FAC
CVO_INSP	The total number of Commercial Vehicle Inspectors who can have simultaneous direct access to ITS at any one time in the ITS area under study. This will be dependent on the number of Commercial Vehicle Roadside facilities (CVO_FAC).	=2.5 * CVO_FAC

**Table 6.3-2 Dependent Parameters Used in the Wireline Data Loading Analysis**

<b>Name</b>	<b>Description</b>	<b>Basis</b>
DAY	Constant used in rate calculations, 24 hours	=24 * HOUR
DYNAMIC_TRAVS	The total number of travelers that are utilizing autonomous route guidance. Based on an assumed ratio (AUTOINFRA) and the number of guided travelers (ITS_GUIDED_TRAVS)	= (1 - AUTOINFRA) * ITS_GUIDED_TRAVS
ERMS_CALLS	The rate, in calls per second, at which EMS calls are received over an average 24 hour period.	= ERMS_CALL_RATE * (POPULATION) / DAY
GW_SIZE	Size of a green wave expressed as a number of route segments.	= ERMS_ROUTE_LENGTH / LINK_LENGTH
HIGHWAY_CROSSING_CONTROLLER	The total number of intermodal highway crossing controllers in traffic corridors.	= HIGHWAY_CORRIDORS * CONTROLLERS_PER_HIGHWAY_CORRIDOR
HIGHWAY_INDICATORS	Total number of indicators (variable message signs and multimodal crossing signals) along freeways controlled/monitored within the ITS area under study. Assumed to be proportional to the total freeway mileage.	= HIGHWAY_MILES / 10
HIGHWAY_LINKS	The total number of navigable freeway links within the ITS area under study.	= HIGHWAY_MILES/LINK_LENGTH
HIGHWAY_SIGN_CONTROLLER	The total number of highway sign controllers, assumed to be proportional to the number of highway signs.	= 6 * HIGHWAY_SIGNS
HIGHWAY_SIGNS	Total number of variable message signs along freeways controlled/monitored within the ITS area under study. Assumed to be proportional to the total number of freeway ramps.	= RAMPS / 4
HOUR	Constant used in rate calculations, 60 minutes	=60 * MINUTE
HOV_LANES	The total number of high-occupancy links being controlled/monitored within the ITS area under study. Based on the total number of its freeway links.	= .05 * HIGHWAY_LINKS
INCIDENTS	The average number of incidents in a 24 hour period, based on the incident rate (INCIDENT_RATE) and general vehicle population (VEHS).	= INCIDENT_RATE * VEHS
INDICATORS	Total number of indicators (intersection controllers, pedestrian controllers, variable message signs and multimodal crossings) controlled/monitored within the ITS area under study. Assumed to be proportional to the number of intersections.	= HIGHWAY_INDICATORS + ROAD_INDICATORS
INT_CONTROLLERS	The total number of roadway intersection controllers in traffic corridors.	= CORRIDORS * INTERSECTIONS_PER_CORRIDOR
ITS_CVO_VEHS	The total number of commercial vehicles within the ITS area under study that are equipped to utilize ITS functions.	= MPCV * COM_VEHS
ITS_GUIDED_TRAVS	The total number of travelers who can utilize ITS personal traveler guidance functions. This will be a proportion of the number of travelers who can simultaneously utilize ITS functions (ITS_TRAVS).	= 0.3 * ITS_TRAVS
ITS_GUIDED_VEHS	The total number of vehicles that are utilizing ITS functions to obtain dynamic in-vehicle route guidance. This is a subset of the subset of all types of vehicles equipped to utilize ITS functions (ACT_ERMS_VEHS, ITS_CVO_VEHS, ITS_PVT_VEHS, ITS_PTRANSIT)	= ACT_ERMS_VEHS + 0.9 * ITS_CVO_VEHS + 0.25 * ITS_PVT_VEHS + 0.8 * ITS_PTRANSIT_VEHS + 0.2 * ITS_TRANSIT_VEHS

**Table 6.3-2 Dependent Parameters Used in the Wireline Data Loading Analysis**

<b>Name</b>	<b>Description</b>	<b>Basis</b>
ITS_PARATRANSIT_VEHS	The total number of flexible transit vehicles operating within the ITS area under study that are equipped to utilize ITS functions. This will be a proportion of the total number of paratransit vehicles (PARATRANSIT_VEHS).	=MPPTV*PARATRANSIT_VEHS
ITS_PTRANSIT_TRAVS	The total number of travelers who are utilizing ITS functions to obtain information on flexible transit services and (possibly) make reservation for one of those services. This is a proportion of the total number of travelers who can utilize ITS functions.	= MPPTT*ITS_TRAVS
ITS_PTRANSIT_VEHS	The total number of Paratransit vehicles operating within the ITS area under study that are equipped to utilize ITS functions. This will be a proportion of the total number of Paratransit vehicles (PTRANSIT_VEHS).	=0.9 * PTRANSIT_VEHS
ITS_PVT_VEHS	The total number of private vehicles within the ITS area under study that are equipped to utilize ITS functions.	= MPPV * PVT_VEHS
ITS_RS_TRAVS	The total number of travelers who are utilizing ITS functions to obtain Ridematching information and (possibly) make Ridematching reservations. This is a proportion of the total number of travelers who can utilize ITS functions (ITS_TRAVS).	= 0.1 * ITS_TRAVS
ITS_TRANSIT_USERS	The total number of transit users operating within the ITS area under study that utilize ITS functions. This will be a proportion of the total number of transit users (TRANSIT_USERS).	=MPTU * TRANSIT_USERS
ITS_TRANSIT_VEHS	The total number of transit vehicles operating within the ITS area under study that are equipped to utilize ITS functions. This will be a proportion of the total number of transit vehicles (TRANSIT_VEHS).	=MPTV * TRANSIT_VEHS
ITS_TRAVS	The total number of travelers who can simultaneously utilize ITS functions. This is a proportion of the total population (POPULATION).	= MPTR * POPULATION
ITS_VEHICLES	The total number of vehicles within the ITS area under study that are equipped to utilize ITS functions.	= ACT_ERMS_VEHS + ITS_CVO_VEHS + ITS_PVT_VEHS + ITS_PTRANSIT_VEHS + ITS_TRANSIT_VEHS
KIOSK_EMERGENCIES	Number of emergency calls per second being transmitted from ITS Kiosks. This assumed to be proportional to the number of ITS travelers (ITS_TRAVS), the expected rate of emergency calls within the general population (ERMS_CALL_RATE) and the market penetration.	= MPKIOSK * ERMS_CALL_RATE * ITS_TRAVS
LAST_PMODEL_UPDATE	This parameter is defined to provide a record of when the last time this table was updated. It is the Excel time serial corresponding to the last time this table was updated by PMODEL.XLS	= NOW()
LINKS	The total number of navigable links within the ITS area under study.	= ROAD_LINKS + HIGHWAY_LINKS
MAX_ADJ_CUR_INCIDENTS	The subset of maximum number of predicted incidents for a 24 hour period that will impact traffic conditions in another area.	= .2 * MAX_CUR_INCIDENTS
MAX_ADJ_PRED_INCIDENTS	The subset of maximum number of predicted incidents for a 24 hour period that will impact traffic conditions in another area.	= .2 * MAX_PRED_INCIDENTS



**Table 6.3-2 Dependent Parameters Used in the Wireline Data Loading Analysis**

<b>Name</b>	<b>Description</b>	<b>Basis</b>
MAX_ADV_CHARGES	The maximum number of advanced charges, Assumed to be 1% of the general ITS population, i.e. it is proportional to the general market penetration of ITS (MP).	= .01 * MP * POPULATION
MAX_ADV_FARES	The maximum number of advanced fares, Assumed to be 1% of the general ITS population, i.e. it is proportional to the general market penetration of ITS (MP).	= .01 * MP * POPULATION
MAX_ADV_TOLLS	The maximum number of advanced tolls, Assumed to be 1% of the general ITS population, i.e. it is proportional to the general market penetration of ITS (MP).	= .01 * MP * POPULATION
MAX_AHS_CHECKS	The maximum number of AHS check-in/check-out facilities.	= AHS_MILES / AHS_SEGMENT_LENGTH
MAX_BAD_PAYERS	The expected number of travelers who are known to the ITS system as bad credit risks, assumed to be a percentage of all ITS_TRAVELERS.	= .0001 * ITS_TRAVS
MAX_CUR_INCIDENTS	The maximum number of predicted incidents for a 24 hour period.	= INCIDENTS
MAX_LINKS	The maximum allowable number of segments into which a valid route may be divided.	= MAX_SEGS
MAX_PARKING_SENSORS	The maximum number of parking lot sensors, Assumed to be proportional to the number of PARKING_LOTS.	= 10 * PARKING_LOTS
MAX_PARKING_VMS	The maximum number of parking variable message signs, Assumed to be proportional to the number of PARKING_LOTS.	= 4 * PARKING_LOTS
MAX_PRED_INCIDENTS	The maximum number of predicted incidents for a 24 hour period.	= INCIDENTS
MAX_SEGS	The total number of navigable links within the ITS area under study.	= LINKS
MAX_SENSORS	The maximum number of ITS sensors, Assumed to be proportional to the number of intersections in the ITS area under study.	= 10 * INTERSECTIONS
MILES	The total number of miles in the area under study.	= HIGHWAY_MILES + ROAD_MILES
MINUTE	Constant used in rate calculations, 60 seconds	=60
MONTH	Constant used in rate calculations, 1/12 of a year	=YEAR / 12
NUM_CVO_RECORDS	The estimated number of records in the average CVO roadside database. It is based on an estimate of the total number of vehicles legally enrolled to operate in the ITS area under study. This will include all enrolled vehicles registered in the jurisdiction.	=MPCV*CVO_VEHS
NUM_PREDICTED_INCIDENTS	The predicted number of incidents in a 24 hour period.	= INCIDENTS
NUM_TRANSIT_SERVICES	The maximum number of vehicle schedules for a typical transit route. This is determined the TRANSIT_WAIT_TIME, i.e. an average wait time of 60 minutes requires 24 TRANSIT_SERVICES per 24 hour period.	= 24 * 60 / TRANSIT_WAIT_TIME
OTHER_SEGS	The total number of navigable non-vehicular segments within the ITS area under study.	= .1 * ROAD_LINKS
PARATRANSIT_VEHS	The total number of paratransit vehicles operating within the ITS area under study. A paratransit vehicle is one that is used to carry one or passengers on a non-scheduled transit service that may not follow a fixed route.	= .25 * TRANSIT_VEHS

**Table 6.3-2 Dependent Parameters Used in the Wireline Data Loading Analysis**

<b>Name</b>	<b>Description</b>	<b>Basis</b>
PARKING_LOT_PROVIDERS	The average number of independent parking service providers in the ITS area under study.	= PARKING_PROVIDER_RATE * POPULATION
PARKING_LOTS	The average total number of parking lots that are being operated by a single parking lot service provider in the ITS area under study.	= PARKING_LOTS_PER_PROVIDER * PARKING_LOT_PROVIDERS
PARKING_SAMPLE_RATE	An arbitrary sample rate constant used to facilitate data loading estimates for parking lot operations.	= 1 / DAY
PARKING_SPACES	The total average number of parking spaces available in the ITS area under study.	= PARKING_SPACE_RATE * VEHS
PED_CONTROLLERS	The total number of pedestrian activated signal controllers within the ITS area under study. This is dependent on the total number of intersections.	= .1 * INTERSECTIONS
PEDESTRIAN_SIGNAL_CONTROLLERS	The total number of pedestrian activated signal controllers within the ITS area under study. This is dependent on the total number of intersections.	= .1 * INTERSECTIONS
PERSONAL_EMERGENCIES	Number of emergency calls per second being transmitted from Personal Data Assistant (PDA) type devices. This assumed to be proportional to the number of ITS travelers (ITS_TRAVS), the expected rate of emergency calls within the general population.	= MPPDA * ERMS_CALL_RATE * ITS_TRAVS
POLLUTION_POINTS	The expected number of environmental pollution monitoring points (i.e. roadside transponders) . This number is assumed to be proportional to the number of intersections (INTERSECTIONS) in the area under study, and to a installed rate (EP_MONITOR_DENSITY)	= EP_MONITOR_DENSITY * INTERSECTIONS
RAMP_CONTROLLERS	The total number of ramp controllers, based on the number of ramps, within the ITS area under study.	= 2 * RAMPS
ROAD_CROSSING_CONTROLLERS	The total number of intermodal road crossing controllers in traffic corridors.	= ROAD_CORRIDORS * CONTROLLERS_PER_ROAD_CORRIDOR
ROAD_INDICATORS	Total number of indicators (intersection controllers, pedestrian controllers, variable message signs and multimodal crossings) along roads controlled/monitored within the ITS area under study. Assumed to be proportional to the number of intersections.	= 4 * INTERSECTIONS
ROAD_LINKS	The total number of navigable surface street links within the ITS area under study.	= ROAD_MILES/LINK_LENGTH
ROAD_SIGN_CONTROLLERS	The total number of road sign controllers, assumed to be proportional to the number of road signs.	= 6 * ROAD_SIGNS
ROAD_SIGNS	Total number of variable message signs along roads controlled/monitored within the ITS area under study. Assumed to be proportional to the number of intersections.	= INTERSECTIONS / 10
ROADWAY_SEGS	The total number of navigable route segments within the ITS area under study.	= LINKS
ROUTES	The average number of routes requested during an average 24 hour period, based on the total number of ITS vehicles and travelers within the ITS area under study.	=2* (ITS_GUIDED_VEHS+ITS_GUIDED_TRAVS)

**Table 6.3-2 Dependent Parameters Used in the Wireline Data Loading Analysis**

<b>Name</b>	<b>Description</b>	<b>Basis</b>
SAMPLE_RATE	An arbitrary sample rate constant used to facilitate data loading estimates.	= 1/(5*MINUTE)
SIGN_CONTROLLERS	The total number of roadway sign controllers, assumed to be proportional to the number of signs.	= HIGHWAY_SIGN_CONTROLLERS+ROAD_SIGN_CONTROLLERS
SIGNS	The total number of HIGHWAY_SIGNS and ROAD_SIGNS	= HIGHWAY_SIGNS+ROAD_SIGNS
TOLL_SAMPLE_RATE	An arbitrary sample rate constant used to facilitate data loading estimates for toll road operations.	= 1/DAY
TOLL_SEGS	Total number of Toll Segments within the ITS area under study. This is a percentage of the number of toll miles.	= .10 * TOLL_MILES
TOTAL_SEGS	The total number of navigable links within the ITS area under study.	= LINKS
TRANSIT_DEVS	The total number of transit vehicles that are running late, i.e. deviating from their routes and/or schedules at any particular moment within the ITS area under study. This will be proportional to the total number of transit vehicles currently running.	= .5 * TRANSIT_VEH_DEVS * TRANSIT_STOPS
TRANSIT_KIOSKS	The total number of transit stops within the ITS area under study that are also equipped as kiosks and able to support inquiries from transit users for information on transit services. This will be dependent on the number of transit stops (TRANSIT_STOPS)	= KIOSKS_PER_TRANSIT_STOP * TRANSIT_STOPS
TRANSIT_ROUTE_SEGS	The average (typical) number of route segments in a typical (average) transit route.	= TRANSIT_STOPS / NUM_TRANSIT_ROUTES
TRANSIT_SAMPLE_RATE	An arbitrary sample rate constant used to facilitate data loading estimates for transit operations.	= 1 / DAY
TRANSIT_SEGS	The average (typical) number of route segments in a typical (average) transit route.	= TRANSIT_STOPS / NUM_TRANSIT_ROUTES
TRANSIT_TECH_ACTS	Transit Technician Activities, assumed to be proportional to the number of TRANSIT_VEHS.	= 2 * TRANSIT_VEHS
TRANSIT_TECHS	The total number of transit service technicians available to maintain the transit fleet within the ITS area under study. This number is assumed to be proportional to the size of the transit system as measured by the number of TRANSIT_VEHS	= TRANSIT_VEHS / 50
TRANSIT_USERS	The average number of travelers in the general population (POPULATION) using transit facilities on a daily basis.	= TRANSIT_USAGE_RATE * POPULATION
TRANSIT_VEH_DEVS	The total number of transit vehicles that are running late, i.e. deviating from their routes and/or schedules at any particular moment within the ITS area under study. This will be proportional to the total number of transit vehicles (TRANSIT_VEHS).	= 0.1 * TRANSIT_VEHS
TRANSIT_VIDEO_CAMS	The total number of video sources within the ITS area under study that are dedicated to the surveillance of transit operations. This number is based on the total number of TRANSIT_STOPS in the transit system.	= TRANSIT_STOPS / 8
VEHICLE_SIGN_OUTPUTS	The expected number of in-vehicle signage transmission points (i.e. roadside transponders). This number is assumed to be proportional to the number of intersections (INTERSECTIONS) and to the rate of implementation (VEHICLE_SIGN_OUTPUT_DENSITY)	= VEHICLE_SIGN_OUTPUT_DENSITY * INTERSECTIONS

**Table 6.3-2 Dependent Parameters Used in the Wireline Data Loading Analysis**

<b>Name</b>	<b>Description</b>	<b>Basis</b>
VEHS	The assumed total number of vehicles in the ITS area under study, based on the general population of the same area.	= .63 * POPULATION
WEEK	Constant used in rate calculations, 7 days	= 7 * DAY
YEAR	Constant used in rate calculations, 365.24 days	= 365.24 * DAY

The data loads calculated from these parameters can be considered the average data load. When determining the link data load, in addition to this average data load, the latency-driven peak link loads must be calculated. The maximum of these two (average load and peak link load) was used to determine the link data rate due to that particular message. The data loads resulting from all of the messages that flow over a particular link were summed.

The latencies were all set initially to 0.1 seconds. Where this decision caused a link data rate to be mainly driven by the latency requirement for a particular large message, the latency requirement was adjusted where it was not required to be so low. An example is the transmission of semi-annual reports where latency is not an issue.

The wireline data loading analysis is shown in Table 6.3-3. The table lists the wireline link in the left column, the message name, the frequency, the message size, the average link load based on the frequency and size, the latency requirement assumed, the peak link load based on size and latency, the maximum of the two load calculations, and finally the type of wireline leased digital link required to carry this load. As in the wireless analysis section in this document, no recommendation as to the specific link selection has been made. Private fiber networks can be deployed to carry all or part of this traffic. The selection of a leased digital link type is for illustration only. There are three digital link types assigned in this table: DS0 for up to 56 Kbps, DS1 for up to 1.544 Mbps, and DS3 for over 1.544 Mbps. The largest rate link shown is DS3 (46 Mbps), multiple links may be required in some cases. Additionally, it may be less costly to use multiple lower-rate links and not jump up to the next higher rate link when a threshold is reached. The summary for each link is in bold within a box for each link.

**Table 6.3-3 Wireline Data Loading Analysis, 2012, Urbansville**

Wireline Link	Message	Frequency (/sec)	Message Size (bits)	Ave. Link Load (b/s)	Latency (sec)	Peak Link Load (b/s)	Max. Load (b/s)	Link Type
Construction and Maintenance to TMS	fcm_fault_clearance	0.002762541	82	0.226528323	0.1	820	820	
Construction and Maintenance to TMS	fcm_incident_information	0.002762541	146	0.403330916	0.1	1460	1460	
<b>Construction and Maintenance to TMS Total</b>				0.629859239		2280	2280	DS0
CVAS to CVCS	cv_credentials_database_update	1.15741E-05	482	0.005578704	0.1	4820	4820	
CVAS to CVCS	cv_credentials_information_response	0.00015	410	0.0615	0.1	4100	4100	
CVAS to CVCS	cv_safety_database_update	1.15741E-05	410	0.00474537	0.1	4100	4100	
CVAS to CVCS	cv_safety_information_response	0.0015	410	0.615	0.1	4100	4100	
<b>CVAS to CVCS Total</b>				0.686824074		17120	17120	DS0
CVAS to DMV	tdmv_cv_violation_identity_code	1.15741E-05	34	0.000393519	0.1	340	340	
CVAS to DMV	tdmv_cv_violation_vehicle_license	1.15741E-05	146	0.001689815	0.1	1460	1460	
<b>CVAS to DMV Total</b>				0.002083333		1800	1800	DS0
CVAS to Enforcement Agency	tea_cv_violation_data	1.15741E-05	274	0.003171296	0.1	2740	2740	
<b>CVAS to Enforcement Agency Total</b>				0.003171296		2740	2740	DS0
CVAS to Financial Institution	tfi_cv_payment_request	0.08385086	274	22.97513558	0.1	2740	2740	

**Table 6.3-3 Wireline Data Loading Analysis, 2012, Urbansville**

Wireline Link	Message	Frequency (/sec)	Message Size (bits)	Ave. Link Load (b/s)	Latency (sec)	Peak Link Load (b/s)	Max. Load (b/s)	Link Type
<b>CVAS to Financial Institution Total</b>				22.97513558		2740	2740	DS0
CVAS to FMS	cf_clearance_enrollment_confirm	1.15741E-05	26	0.000300926	0.1	260	260	
CVAS to FMS	cf_enrollment_information	0.090300926	3818	344.7689352	0.1	38180	38180	
CVAS to FMS	cf_enrollment_payment_confirmation	0.051600529	170	8.772089947	0.1	1700	1700	
CVAS to FMS	cv_enrollment_information	0.006450066	3818	24.62635251	0.1	38180	38180	
CVAS to FMS	cv_enrollment_payment_confirmation	0.025800265	346	8.926891534	0.1	3460	3460	
<b>CVAS to FMS Total</b>				387.0945701		81780	81780	DS1
CVAS to Government Administrators	tga_quarterly_reports	1.28601E-07	8000018	1.028808899	60	133333.6333	133333.6333	
CVAS to Government Administrators	tga_request_fees_updates	0.051600529	8000018	412805.1616	10	800001.8	800001.8	
<b>CVAS to Government Administrators Total</b>				412806.1904		933335.4333	933335.4333	DS1
CVAS to Other CVAS	tocvas_data_table	0.013545139	8210	111.2055903	1	8210	8210	
CVAS to Other CVAS	tocvas_enrollment_confirmation	0.013545139	82	1.110701389	0.1	820	820	
CVAS to Other CVAS	tocvas_enrollment_request	0.013545139	50	0.677256944	0.1	500	500	
CVAS to Other CVAS	tocvas_provide_data	0.013545139	50	0.677256944	0.1	500	500	

**Table 6.3-3 Wireline Data Loading Analysis, 2012, Urbansville**

Wireline Link	Message	Frequency (/sec)	Message Size (bits)	Ave. Link Load (b/s)	Latency (sec)	Peak Link Load (b/s)	Max. Load (b/s)	Link Type
<b>CVAS to Other CVAS Total</b>				113.6708056		10030	10030	DS0
CVAS to PS	cv_operational_data	1.15741E-05	8192018	94.81502315	10	819201.8	819201.8	
<b>CVAS to PS Total</b>				94.81502315		819201.8	819201.8	DS1
CVCS to CVAS	cv_credentials_information_request	0.00015	554	0.0831	0.1	5540	5540	
CVCS to CVAS	cv_roadside_daily_log	1.15741E-05	3362	0.038912037	0.1	33620	33620	
CVCS to CVAS	cv_safety_information_request	0.0015	554	0.831	0.1	5540	5540	
CVCS to CVAS	cv_safety_information_request	0.162541667	554	90.04808333	0.1	5540	5540	
CVCS to CVAS	cv_update_safety_problems_list	0.000015	538	0.00807	0.1	5380	5380	
<b>CVCS to CVAS Total</b>				91.00916537		55620	55620	DS0
DMV to CVAS	fdmv_cv_violation_state_identity	1.15741E-05	26	0.000300926	0.1	260	260	
DMV to CVAS	fdmv_cv_violation_vehicle_registration	1.15741E-05	90	0.001041667	0.1	900	900	
<b>DMV to CVAS Total</b>				0.001342593		1160	1160	DS0
DMV to PMS	fdmv_parking_lot_violation_state_identity	0.000925926	26	0.024074074	0.1	260	260	
DMV to PMS	fdmv_parking_lot_violation_vehicle_registration	0.000925926	90	0.083333333	0.1	900	900	

**Table 6.3-3 Wireline Data Loading Analysis, 2012, Urbansville**

Wireline Link	Message	Frequency (/sec)	Message Size (bits)	Ave. Link Load (b/s)	Latency (sec)	Peak Link Load (b/s)	Max. Load (b/s)	Link Type
<b>DMV to PMS Total</b>				0.107407407		1160	1160	DS0
DMV to TAS	fdmv_toll_violation_state_identity	0.000925926	26	0.024074074	0.1	260	260	
DMV to TAS	fdmv_toll_violation_vehicle_registration	0.000925926	90	0.083333333	0.1	900	900	
<b>DMV to TAS Total</b>				0.107407407		1160	1160	DS0
DMV to TMS	fdmv_traffic_violation_state_identity	75.93147035	26	1974.218229	0.1	260	1974.218229	
DMV to TMS	fdmv_traffic_violation_vehicle_registration	75.93147035	90	6833.832332	0.1	900	6833.832332	
<b>DMV to TMS Total</b>				8808.050561		1160	8808.050561	DS0
E911 or ETS to EM	fets_emergency_telephone_service_identity	0.014908949	146	2.176706531	0.1	1460	1460	
E911 or ETS to EM	fets_incident_details	0.002762541	202	0.558033185	0.1	2020	2020	
<b>E911 or ETS to EM Total</b>				2.734739716		3480	3480	DS0
EM to E911 or ETS	tets_incident_acknowledge	0.014908949	26	0.38763267	0.1	260	260	
<b>EM to E911 or ETS Total</b>				0.38763267		260	260	DS0
EM to FMS	cf_hazmat_request	5.78704E-05	146	0.008449074	0.1	1460	1460	
<b>EM to FMS Total</b>				0.008449074		1460	1460	DS0



**Table 6.3-3 Wireline Data Loading Analysis, 2012, Urbansville**

Wireline Link	Message	Frequency (/sec)	Message Size (bits)	Ave. Link Load (b/s)	Latency (sec)	Peak Link Load (b/s)	Max. Load (b/s)	Link Type
EM to ISP	emergency_vehicle_route_request	8.917042303	1370	12216.34795	0.1	13700	13700	
EM to ISP	incident_information	0.001388889	858	1.191666667	0.1	8580	8580	
<b>EM to ISP Total</b>				12217.53962		22280	22280	DS0
EM to Other EM	toec_emergency_telephone_service_identity	0.014908949	146	2.176706531	0.1	1460	1460	
EM to Other EM	toec_incident_details	0.014908949	202	3.011607666	0.1	2020	2020	
<b>EM to Other EM Total</b>				5.188314197		3480	3480	DS0
EM to PS	emergency_vehicle_operational_data	1.15741E-05	819218	9.481689815	15	54614.53333	54614.53333	
<b>EM to PS Total</b>				9.481689815		54614.53333	54614.53333	DS0
EM to RTS	emergency_request_kiosk_traveler_acknowledge	96.6099885	26	2511.859701	0.1	260	2511.859701	
<b>EM to RTS Total</b>				2511.859701		260	2511.859701	DS0
EM to TMS	emergency_vehicle_green_wave	8.917042303	1098	9790.912448	0.1	10980	10980	
EM to TMS	incident_details	0.001388889	218	0.302777778	0.1	2180	2180	
EM to TMS	incident_response_status	0.003333333	826	2.753333333	0.1	8260	8260	
<b>EM to TMS Total</b>				9793.96856		21420	21420	DS0

**Table 6.3-3 Wireline Data Loading Analysis, 2012, Urbansville**

Wireline Link	Message	Frequency (/sec)	Message Size (bits)	Ave. Link Load (b/s)	Latency (sec)	Peak Link Load (b/s)	Max. Load (b/s)	Link Type
EM to TRMS	transit_incident_coordination_data	4.62963E-06	41106	0.190305556	0.1	411060	411060	
<b>EM to TRMS Total</b>				0.190305556		411060	411060	DS1
EMMS to Map Update Provider	tmup_request_pollution_display_u pdate	6.35938E-08	34	2.16219E-06	0.1	340	340	
<b>EMMS to Map Update Provider Total</b>				2.16219E-06		340	340	DS0
EMMS to PS	pollution_operational_data	1.15741E-05	1843458	21.33631944	100	18434.58	18434.58	
<b>EMMS to PS Total</b>				21.33631944		18434.58	18434.58	DS0
EMMS to RS	pollution_state_vehicle_acceptanc e_criteria	0.000277778	642	0.178333333	0.1	6420	6420	
<b>EMMS to RS Total</b>				0.178333333		6420	6420	DS0
EMMS to TMS	pollution_incident	0.001111111	202	0.224444444	0.1	2020	2020	
EMMS to TMS	pollution_state_data	0.003333333	282	0.94	0.1	2820	2820	
EMMS to TMS	wide_area_pollution_data	0.003333333	1024226	3414.086667	30	34140.86667	34140.86667	
<b>EMMS to TMS Total</b>				3415.251111		38980.86667	38980.86667	DS0
Event Promoters to TMS	fep_event_information	4	530	2120	0.1	5300	5300	
<b>Event Promoters to TMS Total</b>				2120		5300	5300	DS0

**Table 6.3-3 Wireline Data Loading Analysis, 2012, Urbansville**

Wireline Link	Message	Frequency (/sec)	Message Size (bits)	Ave. Link Load (b/s)	Latency (sec)	Peak Link Load (b/s)	Max. Load (b/s)	Link Type
Financial Institution to CVAS	ffi_cv_payment_confirm	0.067725694	34	2.302673611	0.1	340	340	
<b>Financial Institution to CVAS Total</b>				2.302673611		340	340	DS0
Financial Institution to ISP	ffi_driver_map_payment_confirm	0.014406915	34	0.489835096	0.1	340	340	
Financial Institution to ISP	ffi_registration_payment_confirm	0.007203457	34	0.244917548	0.1	340	340	
Financial Institution to ISP	ffi_traveler_display_payment_confirm	4.384984954	34	149.0894884	0.1	340	340	
Financial Institution to ISP	ffi_traveler_map_payment_confirm	0.012005763	34	0.408195949	0.1	340	340	
Financial Institution to ISP	ffi_traveler_other_services_payments_confirm	0.006002882	34	0.204097975	0.1	340	340	
Financial Institution to ISP	ffi_traveler_rideshare_payment_confirm	0.004322075	34	0.146950542	0.1	340	340	
<b>Financial Institution to ISP Total</b>				150.5834855		2040	2040	DS0
Financial Institution to PMS	ffi_bad_charges_payment_updates	3.47222E-05	2066	0.071736111	0.1	20660	20660	
Financial Institution to PMS	ffi_confirm_charges_payment	0.128894326	26	3.351252463	0.1	260	260	
<b>Financial Institution to PMS Total</b>				3.422988574		20920	20920	DS0
Financial Institution to TAS	ffi_bad_toll_payment_updates	3.47222E-05	2066	0.071736111	0.1	20660	20660	
Financial Institution to TAS	ffi_confirm_toll_payment	0.128894326	34	4.382407067	0.1	340	340	

**Table 6.3-3 Wireline Data Loading Analysis, 2012, Urbansville**

Wireline Link	Message	Frequency (/sec)	Message Size (bits)	Ave. Link Load (b/s)	Latency (sec)	Peak Link Load (b/s)	Max. Load (b/s)	Link Type
<b>Financial Institution to TAS Total</b>				4.454143178		21000	21000	DS0
Financial Institution to TRMS	ffi_bad_fare_payment_updates	3.47222E-05	2066	0.071736111	0.1	20660	20660	
Financial Institution to TRMS	ffi_confirm_fare_payment	0.128894326	26	3.351252463	0.1	260	260	
Financial Institution to TRMS	ffi_other_services_payment_confirmation	0.007203457	34	0.244917548	0.1	340	340	
<b>Financial Institution to TRMS Total</b>				3.667906122		21260	21260	DS0
FMS to CVAS	cf_enroll_clearance_data	1.15741E-05	402	0.004652778	0.1	4020	4020	
FMS to CVAS	cf_enrollment_payment_request	0.051600529	414	21.36261905	0.1	4140	4140	
FMS to CVAS	cf_enrollment_request	0.090300926	3498	315.8726389	0.1	34980	34980	
FMS to CVAS	cv_enrollment_payment_request	0.045150463	414	18.69229167	0.1	4140	4140	
FMS to CVAS	cv_enrollment_request	0.006450066	3498	22.56233135	0.1	34980	34980	
<b>FMS to CVAS Total</b>				378.4945337		82260	82260	DS1
FMS to EM	cf_hazmat_route_information	0.090300926	3754	338.9896759	0.1	37540	37540	
FMS to EM	cf_hazmat_vehicle_information	1.65344E-06	242	0.000400132	0.1	2420	2420	
<b>FMS to EM Total</b>				338.9900761		39960	39960	DS0

**Table 6.3-3 Wireline Data Loading Analysis, 2012, Urbansville**

Wireline Link	Message	Frequency (/sec)	Message Size (bits)	Ave. Link Load (b/s)	Latency (sec)	Peak Link Load (b/s)	Max. Load (b/s)	Link Type
FMS to Intermodal Freight Depot	To_Intermodal_Freight_Depot	0.010523964	530	5.577700861	0.1	5300	5300	
<b>FMS to Intermodal Freight Depot Total</b>				5.577700861		5300	5300	DS0
FMS to Intermodal Freight Shipper	To_Intermodal_Freight_Shipper	0.010523964	530	5.577700861	0.1	5300	5300	
<b>FMS to Intermodal Freight Shipper Total</b>				5.577700861		5300	5300	DS0
FMS to ISP	cf_route_request	0.090300926	1234	111.4313426	0.1	12340	12340	
FMS to ISP	cv_route_request	0.045150463	1354	61.13372685	0.1	13540	13540	
<b>FMS to ISP Total</b>				172.5650694		25880	25880	DS0
FMS to Payment Instrument	tpi_debited_commercial_manager_payment	0.090300926	50	4.515046296	0.1	500	500	
<b>FMS to Payment Instrument Total</b>				4.515046296		500	500	DS0
Government Administrators to CVAS	fga_carrier_safety_ratings	3.80267E-07	82	3.11819E-05	0.1	820	820	
Government Administrators to CVAS	fga_tax_and_credential_fees	3.80267E-07	530	0.000201542	0.1	5300	5300	
<b>Government Administrators to CVAS Total</b>				0.000232724		6120	6120	DS0
Intermodal Freight Depot to FMS	From_Intermodal_Freight_Depot	0.010523964	530	5.577700861	0.1	5300	5300	
<b>Intermodal Freight Depot to FMS Total</b>				5.577700861		5300	5300	DS0

**Table 6.3-3 Wireline Data Loading Analysis, 2012, Urbansville**

Wireline Link	Message	Frequency (/sec)	Message Size (bits)	Ave. Link Load (b/s)	Latency (sec)	Peak Link Load (b/s)	Max. Load (b/s)	Link Type
Intermodal Freight Shipper to FMS	From_Intermodal_Freight_Shipper	0.010523964	530	5.577700861	0.1	5300	5300	
<b>Intermodal Freight Shipper to FMS Total</b>				5.577700861		5300	5300	DS0
Intermodal Transportation Service Provider to ISP	fitsp_air_services	37886.27	32768018 >10E+08		10	3276801.8	3276801.8	
Intermodal Transportation Service Provider to ISP	fitsp_ferry_services	378.8627	32768018 >10E+08		10	3276801.8	3276801.8	
Intermodal Transportation Service Provider to ISP	fitsp_intermodal_service_confirmation	0.48673333	338	164.5158655	10	33.8	164.5158655	
Intermodal Transportation Service Provider to ISP	fitsp_rail_services	3788.627	32768018 >10E+08		10	3276801.8	3276801.8	
<b>Intermodal Transportation Service Provider to ISP Total</b>				164.5158655		9830439.2	9830569.916	DS3
Intermodal Transportation Service Provider to TRMS	fitsp_transit_service_data	0.000277778	8192018	2275.560556	0.1	81920180	81920180	
<b>Intermodal Transportation Service Provider to TRMS Total</b>				2275.560556		81920180	81920180	DS3
ISP to EM	emergency_vehicle_route	0.08946	3890	347.9994	0.1	38900	38900	
ISP to EM	incident_information_request	0.001388889	170	0.236111111	0.1	1700	1700	
<b>ISP to EM Total</b>				348.2355111		40600	40600	DS0
ISP to Financial Institution	tfi_driver_map_payment_request	0.024003794	274	6.577039641	0.1	2740	2740	
ISP to Financial Institution	tfi_registration_payment_request	3.80267E-07	274	0.000104193	0.1	2740	2740	

**Table 6.3-3 Wireline Data Loading Analysis, 2012, Urbansville**

Wireline Link	Message	Frequency (/sec)	Message Size (bits)	Ave. Link Load (b/s)	Latency (sec)	Peak Link Load (b/s)	Max. Load (b/s)	Link Type
ISP to Financial Institution	tfi_traveler_display_payment_request	2.192492477	274	600.7429387	0.1	2740	2740	
ISP to Financial Institution	tfi_traveler_map_payment_request	0.144069158	274	39.47494942	0.1	2740	2740	
ISP to Financial Institution	tfi_traveler_other_services_payments_request	0.438498495	274	120.1485877	0.1	2740	2740	
ISP to Financial Institution	tfi_traveler_rideshare_payment_request	10.52396389	274	2883.566106	0.1	2740	2883.566106	
<b>ISP to Financial Institution Total</b>				3650.509725		16440	16583.56611	DS0
ISP to FMS	cf_route	0.051600529	3034	156.5560053	0.1	30340	30340	
ISP to FMS	cv_route	0.045150463	3154	142.4045602	0.1	31540	31540	
<b>ISP to FMS Total</b>				298.9605655		61880	61880	DS1
ISP to Intermodal Transportation Service Provider	titsp_air_services_request	526.1981944	530	278885.0431	0.1	5300	278885.0431	
ISP to Intermodal Transportation Service Provider	titsp_confirm_intermodal_service	0.876996991	530	464.8084051	0.1	5300	5300	
ISP to Intermodal Transportation Service Provider	titsp_ferry_services_request	526.1981944	530	278885.0431	0.1	5300	278885.0431	
ISP to Intermodal Transportation Service Provider	titsp_rail_services_request	526.1981944	530	278885.0431	0.1	5300	278885.0431	
<b>ISP to Intermodal Transportation Service Provider Total</b>				837119.9376		21200	841955.1292	DS1
ISP to Map Update Provider	tmup_request_other_routes_map_update	0.016666667	34	0.566666667	0.1	340	340	

**Table 6.3-3 Wireline Data Loading Analysis, 2012, Urbansville**

Wireline Link	Message	Frequency (/sec)	Message Size (bits)	Ave. Link Load (b/s)	Latency (sec)	Peak Link Load (b/s)	Max. Load (b/s)	Link Type
ISP to Map Update Provider	tmup_request_route_selection_map_update	0.016666667	34	0.566666667	0.1	340	340	
<b>ISP to Map Update Provider Total</b>				1.133333333		680	680	DS0
ISP to Media	tm_incident_information	0.0000694	819200	56.85248	10	81920	81920	
ISP to Media	tm_traffic_information	0.001388889	8192018	11377.80278	10	819201.8	819201.8	
ISP to Media	tm_transit_emergency_information	4.62963E-06	8192018	37.92600926	10	819201.8	819201.8	
ISP to Media	tm_transit_incident_information	0.60814766	8192018	4981956.575	10	819201.8	4981956.575	
ISP to Media	tm_transit_schedule_variations	596	2066	1231336	10	206.6	1231336	
ISP to Media	tm_traveler_information_request	0.001388889	82	0.113888889	10	8.2	8.2	
<b>ISP to Media Total</b>				6224765.27		2539740.2	7933624.375	DS3
ISP to Other ISP	toisp_data_supply	0.1753429	163840018	28728183.89	5	32768003.6	32768003.6	
ISP to Other ISP	toisp_request_data	17.53429167	34	596.1659167	0.1	340	596.1659167	
<b>ISP to Other ISP Total</b>				28728780.06		32768343.6	32768599.77	DS3
ISP to PMS	advanced_other_charges_request	301.3333333	514	154885.3333	0.1	5140	154885.3333	
ISP to PMS	advanced_traveler_charges_request	0.438498495	370	162.2444433	0.1	3700	3700	



**Table 6.3-3 Wireline Data Loading Analysis, 2012, Urbansville**

Wireline Link	Message	Frequency (/sec)	Message Size (bits)	Ave. Link Load (b/s)	Latency (sec)	Peak Link Load (b/s)	Max. Load (b/s)	Link Type
ISP to PMS	parking_lot_data_request	52.61981944	34	1789.073861	0.1	340	1789.073861	
ISP to PMS	parking_lot_reservation_request	0.109624624	34	3.727237211	0.1	340	340	
<b>ISP to PMS Total</b>				156840.3789		9520	160714.4072	DS1
ISP to PS	current_other_routes_use	0.003333333	34054	113.5133333	1	34054	34054	
ISP to PS	current_other_routes_use	0.003333333	34054	113.5133333	1	34054	34054	
ISP to PS	current_road_network_use	0.003333333	385234	1284.113333	1	385234	385234	
<b>ISP to PS Total</b>				1511.14		453342	453342	DS1
ISP to RTS	advanced_tolls_and_charges_roadside_confirm	298	426	126948	0.1	4260	126948	
ISP to RTS	traffic_data_for_kiosks	2.192492477	83874957	183895211.5	1	83874956.68	183895211.5	
ISP to RTS	transit_deviations_for_kiosks	2.192492477	357666	784180.0142	0.1	3576660	3576660	
ISP to RTS	traveler_payment_confirmation	0.438498495	666	292.0399979	0.1	6660	6660	
ISP to RTS	traveler_transaction_confirmation	0.438498495	498	218.3722507	0.1	4980	4980	
ISP to RTS	traveler_trip_information	3.332	33314	111002.248	0.1	333140	333140	
ISP to RTS	traveler_yellow_pages_data	526.1981944	987.68	519715.4327	0.1	9876.8	519715.4327	

**Table 6.3-3 Wireline Data Loading Analysis, 2012, Urbansville**

Wireline Link	Message	Frequency (/sec)	Message Size (bits)	Ave. Link Load (b/s)	Latency (sec)	Peak Link Load (b/s)	Max. Load (b/s)	Link Type
<b>ISP to RTS Total</b>				185437567.6		87810533.48	188463315	DS3
ISP to TAS	advanced_other_tolls_request	702.1202133	530	372123.7131	0.1	5300	372123.7131	
ISP to TAS	advanced_traveler_tolls_request	0.93889	530	497.6117	0.1	5300	5300	
<b>ISP to TAS Total</b>				372621.3248		10600	377423.7131	DS1
ISP to TMS	confirm_incident_data_output	0.003333333	26	0.086666667	1	26	26	
ISP to TMS	current_other_routes_use	0.003333333	34054	113.5133333	1	34054	34054	
ISP to TMS	current_road_network_use	0.003333333	385234	1284.113333	1	385234	385234	
ISP to TMS	current_transit_routes_use	0.003333333	50	0.166666667	1	50	50	
ISP to TMS	low_traffic_route	0.001666667	3874	6.456666667	1	3874	3874	
ISP to TMS	media_incident_data_updates	0.000555556	1666	0.925555556	1	1666	1666	
ISP to TMS	request_incident_media_data	0.027777778	50	1.388888889	1	50	50	
ISP to TMS	traffic_data_media_request	0.083333333	34	2.833333333	1	34	34	
<b>ISP to TMS Total</b>				1409.484444		424988	424988	DS1
ISP to TRMS	advanced_other_fares_request	407.4535467	738	300700.7174	0.1	7380	300700.7174	

**Table 6.3-3 Wireline Data Loading Analysis, 2012, Urbansville**

Wireline Link	Message	Frequency (/sec)	Message Size (bits)	Ave. Link Load (b/s)	Latency (sec)	Peak Link Load (b/s)	Max. Load (b/s)	Link Type
ISP to TRMS	advanced_tolls_and_charges_vehicle_confirm	298	426	126948	0.1	4260	126948	
ISP to TRMS	advanced_traveler_fares_request	0.438498495	738	323.6118896	0.1	7380	7380	
ISP to TRMS	paratransit_service_confirmation	0.087699699	218	19.1185344	0.1	2180	2180	
ISP to TRMS	paratransit_trip_request	15.78594583	1418	22384.47119	0.1	14180	22384.47119	
ISP to TRMS	transit_services_advisories_request	0.003333333	274	0.913333333	0.1	2740	2740	
ISP to TRMS	transit_services_guidance_request	0.003333333	466	1.553333333	0.1	4660	4660	
ISP to TRMS	transit_vehicle_deviations_details_request	596	26	15496	0.1	260	15496	
<b>ISP to TRMS Total</b>				465874.3857		43040	482489.1886	DS1
ISP to Yellow Pages Service Providers	typsp_provider_registration_confirm	3.80267E-07	50	1.90134E-05	0.1	500	500	
ISP to Yellow Pages Service Providers	typsp_transaction_request	105.2396389	82	8629.650389	0.1	820	8629.650389	
ISP to Yellow Pages Service Providers	typsp_yellow_pages_info_request	0.003333333	274	0.913333333	0.1	2740	2740	
<b>ISP to Yellow Pages Service Providers Total</b>				8630.563741		4060	11869.65039	DS0
Map Update Provider to EMMS	fmup_pollution_display_update	0.000277778	16384018	4551.116111	15	1092267.867	1092267.867	
<b>Map Update Provider to EMMS Total</b>				4551.116111		1092267.867	1092267.867	DS1

**Table 6.3-3 Wireline Data Loading Analysis, 2012, Urbansville**

Wireline Link	Message	Frequency (/sec)	Message Size (bits)	Ave. Link Load (b/s)	Latency (sec)	Peak Link Load (b/s)	Max. Load (b/s)	Link Type
Map Update Provider to ISP	fmup_other_routes_map_data	0.000277778	81920018	22755.56056	5	16384003.6	16384003.6	
Map Update Provider to ISP	fmup_route_selection_map_data	1.65344E-06	81920018	135.4497652	5	16384003.6	16384003.6	
<b>Map Update Provider to ISP Total</b>				22891.01032		32768007.2	32768007.2	DS3
Map Update Provider to PS	fmup_deployment_map_update	1.65344E-06	81920018	135.4497652	5	16384003.6	16384003.6	
<b>Map Update Provider to PS Total</b>				135.4497652		16384003.6	16384003.6	DS3
Map Update Provider to RTS	fmup_traveler_display_update	1.65344E-06	16384018	27.08997685	5	3276803.6	3276803.6	
<b>Map Update Provider to RTS Total</b>				27.08997685		3276803.6	3276803.6	DS3
Map Update Provider to TMS	fmup_demand_display_update	1.65344E-06	16384018	27.08997685	5	3276803.6	3276803.6	
Map Update Provider to TMS	fmup_incident_display_update	0.331504863	16384018	5431381.634	5	3276803.6	5431381.634	
Map Update Provider to TMS	fmup_traffic_display_update	0.001388889	16384018	22755.58056	5	3276803.6	3276803.6	
<b>Map Update Provider to TMS Total</b>				5454164.305		9830410.8	11984988.83	DS3
Media to ISP	fm_traveler_information	0.000555556	8210	4.561111111	1	8210	8210	
<b>Media to ISP Total</b>				4.561111111		8210	8210	DS0
Multimodal Crossings to RS	fmcc_crossing_close_duration	1.15741E-05	50	0.000578704	0.1	500	500	

**Table 6.3-3 Wireline Data Loading Analysis, 2012, Urbansville**

Wireline Link	Message	Frequency (/sec)	Message Size (bits)	Ave. Link Load (b/s)	Latency (sec)	Peak Link Load (b/s)	Max. Load (b/s)	Link Type
Multimodal Crossings to RS	fmnc_crossing_close_time	1.15741E-05	50	0.000578704	0.1	500	500	
<b>Multimodal Crossings to RS Total</b>				0.001157407		1000	1000	DS0
Other CVAS to CVAS	focvas_data_table	0.013545139	530	7.178923611	0.1	5300	5300	
Other CVAS to CVAS	focvas_enrollment_confirmation	0.013545139	26	0.352173611	0.1	260	260	
Other CVAS to CVAS	focvas_enrollment_request	0.013545139	274	3.711368056	0.1	2740	2740	
Other CVAS to CVAS	focvas_provide_data	0.013545139	66	0.893979167	0.1	660	660	
<b>Other CVAS to CVAS Total</b>				12.13644444		8960	8960	DS0
Other EM to EM	foec_emergency_telephone_service_identity	0.002762541	146	0.403330916	0.1	1460	1460	
Other EM to EM	foec_incident_details	0.002762541	202	0.558033185	0.1	2020	2020	
<b>Other EM to EM Total</b>				0.961364101		3480	3480	DS0
Other ISP to ISP	foisp_data_supply	1.15741E-05	163840018	1896.296505	5	32768003.6	32768003.6	
Other ISP to ISP	foisp_request_data	0.000277778	34	0.009444444	0.1	340	340	
<b>Other ISP to ISP Total</b>				1896.305949		32768343.6	32768343.6	DS3
Other TM to TMS	fotc_data_request	1.15741E-05	66	0.000763889	0.1	660	660	

**Table 6.3-3 Wireline Data Loading Analysis, 2012, Urbansville**

Wireline Link	Message	Frequency (/sec)	Message Size (bits)	Ave. Link Load (b/s)	Latency (sec)	Peak Link Load (b/s)	Max. Load (b/s)	Link Type
Other TM to TMS	fotc_identity	1.15741E-05	50	0.000578704	0.1	500	500	
Other TM to TMS	fotc_transfer_data	1.15741E-05	4973504.1	57.56370465	5	994700.8164	994700.8164	
<b>Other TM to TMS Total</b>				57.56504724		995860.8164	995860.8164	DS1
Other TRM to TRMS	fotrm_transit_services	0.001111111	81920018	91022.24222	60	1365333.633	1365333.633	
<b>Other TRM to TRMS Total</b>				91022.24222		1365333.633	1365333.633	DS1
Parking Operator to PMS	fpo_current_lot_state	0.841917111	50	42.09585556	0.1	500	500	
Parking Operator to PMS	fpo_lot_occupancy	0.841917111	50	42.09585556	0.1	500	500	
<b>Parking Operator to PMS Total</b>				84.19171111		1000	1000	DS0
Parking Service Provider to PMS	fpsp_confirm_advanced_parking_payment	0.03507988	26	0.91207687	0.1	260	260	
Parking Service Provider to PMS	fpsp_current_lot_state	3.367668444	50	168.3834222	0.1	500	500	
Parking Service Provider to PMS	fpsp_lot_occupancy	3.367668444	50	168.3834222	0.1	500	500	
Parking Service Provider to PMS	fpsp_parking_lot_charge_change_response	0.03507988	66	2.315272056	0.1	660	660	
Parking Service Provider to PMS	fpsp_parking_lot_data	0.03507988	146	5.121662426	0.1	1460	1460	
Parking Service Provider to PMS	fpsp_transaction_reports_request	0.03507988	1042	36.55323457	0.1	10420	10420	

**Table 6.3-3 Wireline Data Loading Analysis, 2012, Urbansville**

Wireline Link	Message	Frequency (/sec)	Message Size (bits)	Ave. Link Load (b/s)	Latency (sec)	Peak Link Load (b/s)	Max. Load (b/s)	Link Type
<b>Parking Service Provider to PMS Total</b>				381.6690904		13800	13800	DS0
Payment Instrument to FMS	fpi_commercial_manager_input_credit_identity	0.090300926	114	10.29430556	0.1	1140	1140	
<b>Payment Instrument to FMS Total</b>				10.29430556		1140	1140	DS0
Payment Instrument to PIAS	fpi_traveler_personal_input_credit_identity	2.192492477	178	390.2636609	0.1	1780	1780	
<b>Payment Instrument to PIAS Total</b>				390.2636609		1780	1780	DS0
Payment Instrument to RTS	fpi_confirm_fare_payment_at_roadside	0.10043808	26	2.611390089	0.1	260	260	
Payment Instrument to RTS	fpi_transit_roadside_tag_data	0.10043808	178	17.8779783	0.1	1780	1780	
Payment Instrument to RTS	fpi_transit_user_roadside_input_credit_identity	0.10043808	178	17.8779783	0.1	1780	1780	
Payment Instrument to RTS	fpi_traveler_roadside_input_credit_identity	4.384984954	178	780.5273218	0.1	1780	1780	
<b>Payment Instrument to RTS Total</b>				818.8946685		5600	5600	DS0
PMS to DMV	tdmv_parking_lot_violation_identity_code	0.000925926	34	0.031481481	0.1	340	340	
PMS to DMV	tdmv_parking_lot_violation_vehicle_license	0.000925926	146	0.135185185	0.1	1460	1460	
<b>PMS to DMV Total</b>				0.166666667		1800	1800	DS0
PMS to Enforcement Agency	tea_parking_violation_data	0.000925926	274	0.253703704	0.1	2740	2740	

**Table 6.3-3 Wireline Data Loading Analysis, 2012, Urbansville**

Wireline Link	Message	Frequency (/sec)	Message Size (bits)	Ave. Link Load (b/s)	Latency (sec)	Peak Link Load (b/s)	Max. Load (b/s)	Link Type
<b>PMS to Enforcement Agency Total</b>				0.253703704		2740	2740	DS0
PMS to Financial Institution	tft_parking_lot_payment_violator_data	0.000185185	2066	0.382592593	0.1	20660	20660	
PMS to Financial Institution	tft_request_charges_payment	0.000115741	274	0.031712963	0.1	2740	2740	
<b>PMS to Financial Institution Total</b>				0.414305556		23400	23400	DS0
PMS to ISP	advanced_other_charges_confirm	108.5729722	346	37566.24839	0.1	3460	37566.24839	
PMS to ISP	advanced_traveler_charges_confirm	105.2396389	250	26309.90972	0.1	2500	26309.90972	
PMS to ISP	parking_lot_availability	52.61981944	370	19469.33319	0.1	3700	19469.33319	
PMS to ISP	parking_lot_reservation_confirm	0.109624624	34	3.727237211	0.1	340	340	
<b>PMS to ISP Total</b>				83349.21854		10000	83685.49131	DS1
PMS to Parking Operator	tpo_change_lot_state	0.003333333	50	0.166666667	0.1	500	500	
<b>PMS to Parking Operator Total</b>				0.166666667		500	500	DS0
PMS to Parking Service Provider	tpsp_change_lot_state	0.003333333	82	0.273333333	0.1	820	820	
PMS to Parking Service Provider	tpsp_parking_lot_charge_change_request	0.001111111	50	0.055555556	0.1	500	500	
PMS to Parking Service Provider	tpsp_request_advanced_parking_payment	0.2	82	16.4	0.1	820	820	



**Table 6.3-3 Wireline Data Loading Analysis, 2012, Urbansville**

Wireline Link	Message	Frequency (/sec)	Message Size (bits)	Ave. Link Load (b/s)	Latency (sec)	Peak Link Load (b/s)	Max. Load (b/s)	Link Type
PMS to Parking Service Provider	tpsp_transaction_reports	0.000115741	81920018	9481.483565	100	819200.18	819200.18	
<b>PMS to Parking Service Provider Total</b>				9498.212454		821340.18	821340.18	DS1
PMS to TMS	parking_lot_charge_change_response	0.001111111	26	0.028888889	0.1	260	260	
PMS to TMS	parking_lot_current_occupancy		1	170	0.1	1700	1700	
PMS to TMS	parking_lot_current_state		1	178	0.1	1780	1780	
PMS to TMS	vms_parking_guidance_for_highways		1	1947881.4	10	194788.1405	1947881.405	
PMS to TMS	vms_parking_guidance_for_roads		1	1947881.4	10	194788.1405	1947881.405	
<b>PMS to TMS Total</b>				3896110.838		393316.281	3899502.81	DS3
PMS to TRMS	parking_lot_price_data	0.000192747	8192018	1578.983546	100	81920.18	81920.18	
PMS to TRMS	parking_lot_transaction_reports	0.000115741	8192018	948.1502315	100	81920.18	81920.18	
PMS to TRMS	parking_lot_transit_request	0.005555556	34	0.188888889	0.1	340	340	
<b>PMS to TRMS Total</b>				2527.322666		164180.36	164180.36	DS1
PS to Map Update Provider	tmup_deployment_map_update_request	1.15741E-05	34	0.000393519	0.1	340	340	
PS to Map Update Provider	tmup_map_static_data	1.15741E-05	81920018	948.1483565	100	819200.18	819200.18	

**Table 6.3-3 Wireline Data Loading Analysis, 2012, Urbansville**

Wireline Link	Message	Frequency (/sec)	Message Size (bits)	Ave. Link Load (b/s)	Latency (sec)	Peak Link Load (b/s)	Max. Load (b/s)	Link Type
<b>PS to Map Update Provider Total</b>				948.14875		819540.18	819540.18	DS1
PS to Transportation Planners	ttp_evaluation_results	0.003333333	8192018	27306.72667	100	81920.18	81920.18	
PS to Transportation Planners	ttp_output_data_store	0.003333333	8192018	27306.72667	100	81920.18	81920.18	
PS to Transportation Planners	ttp_output_documentation	0.000277778	81920018	22755.56056	100	819200.18	819200.18	
PS to Transportation Planners	ttp_output_link_data	1.15741E-05	8192018	94.81502315	100	81920.18	81920.18	
PS to Transportation Planners	ttp_simulation_data	0.003333333	8192018	27306.72667	100	81920.18	81920.18	
<b>PS to Transportation Planners Total</b>				104770.5556		1146880.9	1146880.9	DS1
RS to EMMS	pollution_state_roadside_collection	1	218	218	0.1	2180	2180	
RS to EMMS	pollution_state_vehicle_collection	1	178	178	0.1	1780	1780	
RS to EMMS	pollution_state_vehicle_log_data	0.003333333	178	0.593333333	0.1	1780	1780	
<b>RS to EMMS Total</b>				396.5933333		5740	5740	DS0
RS to Multimodal Crossings	tmmc_crossing_clear_at_highways	1	50	50	0.1	500	500	
RS to Multimodal Crossings	tmmc_crossing_clear_at_roads	1	50	50	0.1	500	500	
RS to Multimodal Crossings	tmmc_stop_alternate_mode_at_highways	1	50	50	0.1	500	500	

**Table 6.3-3 Wireline Data Loading Analysis, 2012, Urbansville**

Wireline Link	Message	Frequency (/sec)	Message Size (bits)	Ave. Link Load (b/s)	Latency (sec)	Peak Link Load (b/s)	Max. Load (b/s)	Link Type	
RS to Multimodal Crossings	tmmc_stop_alternate_mode_at_roads	1	50	50	0.1	500	500		
RS to Multimodal Crossings	tmmc_stop_traffic_at_highways	1	50	50	0.1	500	500		
RS to Multimodal Crossings	tmmc_stop_traffic_at_roads	1	50	50	0.1	500	500		
<b>RS to Multimodal Crossings Total</b>						300	3000	3000	DS0
RS to TMS	ahs_checking_details	2.31481E-05	50	0.001157407	0.1	500	500		
RS to TMS	hov_lane_data_input	1	83928.08	83928.08	0.1	839280.8	839280.8		
RS to TMS	incident_analysis_data	1	2066	2066	0.1	20660	20660		
RS to TMS	indicator_input_data_from_highways	1	1802266	1802266	0.1	18022660	18022660		
RS to TMS	indicator_input_data_from_roads	1	3986	3986	0.1	39860	39860		
RS to TMS	roadside_fault_data	3.17969E-08	50	1.58985E-06	0.1	500	500		
RS to TMS	traffic_image_data	60	83904.08	5034244.8	0.1	839040.8	5034244.8		
RS to TMS	traffic_sensor_data	1	3929	3929	0.1	39290	39290		
RS to TMS	vehicle_pollution_alert	75.89397035	402	30509.37608	0.1	4020	30509.37608		
RS to TMS	vehicle_pollution_message_for_highways	75.89397035	362	27473.61727	0.1	3620	27473.61727		

**Table 6.3-3 Wireline Data Loading Analysis, 2012, Urbansville**

Wireline Link	Message	Frequency (/sec)	Message Size (bits)	Ave. Link Load (b/s)	Latency (sec)	Peak Link Load (b/s)	Max. Load (b/s)	Link Type
RS to TMS	vehicle_pollution_message_for_roads	75.89397035	362	27473.61727	0.1	3620	27473.61727	
<b>RS to TMS Total</b>				7015876.492		19813051.6	24082452.21	DS3
RTS to EM	emergency_request_kiosk_traveler_details	96.6099885	370	35745.69575	0.1	3700	35745.69575	
<b>RTS to EM Total</b>				35745.69575		3700	35745.69575	DS0
RTS to ISP	advanced_tolls_and_charges_roadside_request	298	738	219924	0.1	7380	219924	
RTS to ISP	traffic_data_kiosk_request	2.192492477	98	214.8642627	0.1	980	980	
RTS to ISP	transit_deviation_kiosk_request	2.192492477	66	144.7045035	0.1	660	660	
RTS to ISP	traveler_current_condition_request	2.192492477	58	127.1645637	0.1	580	580	
RTS to ISP	traveler_payment_information	0.438498495	978	428.8515285	0.1	9780	9780	
RTS to ISP	traveler_transaction_request	0.438498495	402	176.2763951	0.1	4020	4020	
RTS to ISP	traveler_trip_confirmation	0.438498495	858	376.231709	0.1	8580	8580	
RTS to ISP	traveler_trip_request	2.192492477	1434	3144.034212	0.1	14340	14340	
RTS to ISP	traveler_yellow_pages_information_request	2.192492477	26	57.0048044	0.1	260	260	
<b>RTS to ISP Total</b>				224593.132		46580	259124	DS1

**Table 6.3-3 Wireline Data Loading Analysis, 2012, Urbansville**

Wireline Link	Message	Frequency (/sec)	Message Size (bits)	Ave. Link Load (b/s)	Latency (sec)	Peak Link Load (b/s)	Max. Load (b/s)	Link Type
RTS to Map Update Provider	tmup_request_traveler_display_update	6.35938E-08	34	2.16219E-06	0.1	340	340	
<b>RTS to Map Update Provider Total</b>				2.16219E-06		340	340	DS0
RTS to Payment Instrument	tpi_debited_fare_payment_at_roadside	0.10043808	50	5.021904018	0.1	500	500	
RTS to Payment Instrument	tpi_debited_transit_user_payment_at_roadside	0.10043808	50	5.021904018	0.1	500	500	
RTS to Payment Instrument	tpi_debited_traveler_payment_at_roadside	4.384984954	50	219.2492477	0.1	500	500	
RTS to Payment Instrument	tpi_request_fare_payment_at_roadside	0.10043808	34	3.414894732	0.1	340	340	
<b>RTS to Payment Instrument Total</b>				232.7079505		1840	1840	DS0
RTS to TRMS	fare_collection_roadside_violation_information	0.111111	74154	8239.25094	0.1	741540	741540	
RTS to TRMS	other_services_roadside_request	5.96	2418	14411.28	0.1	24180	24180	
RTS to TRMS	request_roadside_fare_payment	1788	466	833208	0.1	4660	833208	
RTS to TRMS	transit_roadside_fare_payment_confirmation	0.10043808	26	2.611390089	0.1	260	260	
RTS to TRMS	transit_roadside_passenger_data	1.333	122	162.626	0.1	1220	1220	
RTS to TRMS	transit_services_kiosk_request	2.192492477	314	688.4426377	0.1	3140	3140	
RTS to TRMS	transit_services_travelers_request	0.13391744	466	62.40552727	0.1	4660	4660	

**Table 6.3-3 Wireline Data Loading Analysis, 2012, Urbansville**

Wireline Link	Message	Frequency (/sec)	Message Size (bits)	Ave. Link Load (b/s)	Latency (sec)	Peak Link Load (b/s)	Max. Load (b/s)	Link Type
RTS to TRMS	transit_user_roadside_image	3.973788156	73746	293050.9814	0.1	737460	737460	
<b>RTS to TRMS Total</b>				1149825.598		1517120	2345668	DS3
Secure Area Environment to TRMS	fsa_transit_panic_button	4.62963E-06	50	0.000231481	0.1	500	500	
Secure Area Environment to TRMS	fsa_transit_video_image	30	8388626	251658780	0.1	83886260	251658780	
<b>Secure Area Environment to TRMS Total</b>				251658780		83886760	251659280	DS3
TAS to DMV	tdmv_toll_violation_identity_code	0.000925926	34	0.031481481	0.1	340	340	
TAS to DMV	tdmv_toll_violation_vehicle_licens e	0.000925926	146	0.135185185	0.1	1460	1460	
<b>TAS to DMV Total</b>				0.166666667		1800	1800	DS0
TAS to Enforcement Agency	tea_toll_violation_data	0.000925926	274	0.253703704	0.1	2740	2740	
<b>TAS to Enforcement Agency Total</b>				0.253703704		2740	2740	DS0
TAS to Financial Institution	tfi_request_toll_payment	0.000115741	274	0.031712963	0.1	2740	2740	
TAS to Financial Institution	tfi_toll_payment_violator_data	0.000185185	2066	0.382592593	0.1	20660	20660	
<b>TAS to Financial Institution Total</b>				0.414305556		23400	23400	DS0
TAS to ISP	advanced_other_tolls_confirm	509.3598522	346	176238.5089	0.1	3460	176238.5089	

**Table 6.3-3 Wireline Data Loading Analysis, 2012, Urbansville**

Wireline Link	Message	Frequency (/sec)	Message Size (bits)	Ave. Link Load (b/s)	Latency (sec)	Peak Link Load (b/s)	Max. Load (b/s)	Link Type
TAS to ISP	advanced_traveler_tolls_confirm	105.2396389	250	26309.90972	0.1	2500	26309.90972	
TAS to ISP	vehicle_toll_probe_data	0.003333333	202	0.673333333	0.1	2020	2020	
<b>TAS to ISP Total</b>				202549.0919		7980	204568.4186	DS1
TAS to PS	toll_operational_data	1.15741E-05	58.004167	0.000671345	0.1	580.0416667	580.0416667	
<b>TAS to PS Total</b>				0.000671345		580.0416667	580.0416667	DS0
TAS to TCS	advanced_toll_needed	509.8598522	530	270225.7217	0.1	5300	270225.7217	
TAS to TCS	toll_bad_payment_check_response	0.666666667	314	209.3333333	0.1	3140	3140	
<b>TAS to TCS Total</b>				270435.055		8440	273365.7217	DS1
TAS to TMS	probe_data_for_traffic	0.003333333	8210	27.36666667	0.1	82100	82100	
TAS to TMS	toll_price_changes_response	0.001111111	26	0.028888889	0.1	260	260	
<b>TAS to TMS Total</b>				27.39555556		82360	82360	DS1
TAS to Toll Service Provider	ttsp_credit_identity	509.8598522	146	74439.53842	0.1	1460	74439.53842	
TAS to Toll Service Provider	ttsp_toll_price_changes_request	0.001111111	82	0.091111111	0.1	820	820	
TAS to Toll Service Provider	ttsp_toll_segments	509.8598522	530	270225.7217	0.1	5300	270225.7217	

**Table 6.3-3 Wireline Data Loading Analysis, 2012, Urbansville**

Wireline Link	Message	Frequency (/sec)	Message Size (bits)	Ave. Link Load (b/s)	Latency (sec)	Peak Link Load (b/s)	Max. Load (b/s)	Link Type
TAS to Toll Service Provider	ttsp_transaction_reports	0.002777778	81920018	227555.6056	20	4096000.9	4096000.9	
TAS to Toll Service Provider	ttsp_vehicle_identity	509.8598522	274	139701.5995	0.1	2740	139701.5995	
<b>TAS to Toll Service Provider Total</b>				711922.5563		4106320.9	4581187.76	DS3
TAS to TRMS	toll_price_data	3.81563E-06	914	0.003487485	0.1	9140	9140	
TAS to TRMS	toll_transaction_reports	0.002777778	8192018	22755.60556	20	409600.9	409600.9	
<b>TAS to TRMS Total</b>				22755.60904		418740.9	418740.9	DS1
TCS to TAS	advanced_toll_transactions	0.833333333	338	281.6666667	0.1	3380	3380	
TCS to TAS	confirm_advanced_tolls_payment	0.5	410	205	0.1	4100	4100	
TCS to TAS	current_toll_transactions	0.666666667	786	524	0.1	7860	7860	
TCS to TAS	toll_bad_payment_check_request	0.666666667	306	204	0.1	3060	3060	
TCS to TAS	toll_payment_violator_data	0.000555556	322	0.178888889	0.1	3220	3220	
TCS to TAS	toll_violation_information	0.000925926	8192018	7585.201852	10	819201.8	819201.8	
<b>TCS to TAS Total</b>				8800.047407		840821.8	840821.8	DS1
TMS to Construction and Maintenance	tcm_fault_data	0.000235806	82	0.019336081	0.1	820	820	



**Table 6.3-3 Wireline Data Loading Analysis, 2012, Urbansville**

Wireline Link	Message	Frequency (/sec)	Message Size (bits)	Ave. Link Load (b/s)	Latency (sec)	Peak Link Load (b/s)	Max. Load (b/s)	Link Type
TMS to Construction and Maintenance	tcm_incident_confirmation	0.002762541	26	0.071826054	0.1	260	260	
TMS to Construction and Maintenance	tcm_request_incident_change	0.002762541	274	0.756936103	0.1	2740	2740	
<b>TMS to Construction and Maintenance Total</b>				0.848098237		3820	3820	DS0
TMS to DMV	tdmv_traffic_violation_identity_code	75.93147035	34	2581.669992	0.1	340	2581.669992	
TMS to DMV	tdmv_traffic_violation_vehicle_license	75.93147035	146	11085.99467	0.1	1460	11085.99467	
<b>TMS to DMV Total</b>				13667.66466		1800	13667.66466	DS0
TMS to EM	incident_alert	0.000277778	842	0.233888889	0.1	8420	8420	
TMS to EM	incident_details_request	0.001388889	170	0.236111111	0.1	1700	1700	
TMS to EM	incident_response_clear	0.000277778	146	0.040555556	0.1	1460	1460	
<b>TMS to EM Total</b>				0.510555556		11580	11580	DS0
TMS to EMMS	pollution_state_data_request	0.003333333	50	0.166666667	0.1	500	500	
<b>TMS to EMMS Total</b>				0.166666667		500	500	DS0
TMS to Enforcement Agency	tea_traffic_violation_data	75.93147035	274	20805.22288	0.1	2740	20805.22288	
<b>TMS to Enforcement Agency Total</b>				20805.22288		2740	20805.22288	DS0

**Table 6.3-3 Wireline Data Loading Analysis, 2012, Urbansville**

Wireline Link	Message	Frequency (/sec)	Message Size (bits)	Ave. Link Load (b/s)	Latency (sec)	Peak Link Load (b/s)	Max. Load (b/s)	Link Type
TMS to Event Promoters	tep_event_confirmation	0.000277778	26	0.007222222	0.1	260	260	
<b>TMS to Event Promoters Total</b>				0.007222222		260	260	DS0
TMS to ISP	current_highway_network_state	0.4	339034	135613.6	0.1	3390340	3390340	
TMS to ISP	current_road_network_state	0.4	339034	135613.6	0.1	3390340	3390340	
TMS to ISP	incident_data_output	0.003333333	530	1.766666667	0.1	5300	5300	
TMS to ISP	link_data_for_guidance	1.15741E-05	578	0.006689815	0.1	5780	5780	
TMS to ISP	predicted_incidents	0.003333333	194791.74	649.3057894	10	19479.17368	19479.17368	
TMS to ISP	prediction_data	0.001111111	400634	445.1488889	0.1	4006340	4006340	
TMS to ISP	retrieved_incident_media_data	0.0055556	90124442	500695.35	10	9012444.2	9012444.2	
TMS to ISP	traffic_data_for_media	0.083333333	8192018	682668.1667	5	1638403.6	1638403.6	
TMS to ISP	traffic_data_media_parameters	1.65344E-06	530	0.000876323	0.1	5300	5300	
<b>TMS to ISP Total</b>				1455686.946		21473726.97	21473726.97	DS3
TMS to Map Update Provider	tmup_request_demand_display_u pdate	6.35938E-08	34	2.16219E-06	0.1	340	340	
TMS to Map Update Provider	tmup_request_incident_display_up date	6.35938E-08	34	2.16219E-06	0.1	340	340	

**Table 6.3-3 Wireline Data Loading Analysis, 2012, Urbansville**

Wireline Link	Message	Frequency (/sec)	Message Size (bits)	Ave. Link Load (b/s)	Latency (sec)	Peak Link Load (b/s)	Max. Load (b/s)	Link Type
TMS to Map Update Provider	tmup_request_traffic_display_update	1.27188E-07	34	4.32438E-06	0.1	340	340	
<b>TMS to Map Update Provider Total</b>				8.64876E-06		1020	1020	DS0
TMS to Other TM	totc_data_request	0.003333333	66	0.22	0.1	660	660	
TMS to Other TM	totc_identity	0.003333333	50	0.166666667	0.1	500	500	
TMS to Other TM	totc_transfer_data	1.15741E-05	87713260	1015.199769	5	17542652.02	17542652.02	
<b>TMS to Other TM Total</b>				1015.586436		17543812.02	17543812.02	DS3
TMS to PMS	parking_lot_charge_change_request	0.001111111	322	0.357777778	0.1	3220	3220	
TMS to PMS	parking_lot_input_data	1	509217.47	509217.4688	10	50921.74688	509217.4688	
TMS to PMS	selected_parking_lot_control_strategy	0.066666667	436507.83	29100.52203	10	43650.78304	43650.78304	
TMS to PMS	static_data_for_parking_lots	1.15741E-05	128048	1.482037037	10	12804.8	12804.8	
<b>TMS to PMS Total</b>				538319.8306		110597.3299	568893.0518	DS1
TMS to PS	ahs_operational_data	1.15741E-05	26.028642	0.000301257	0.1	260.2864198	260.2864198	
TMS to PS	current_incident_static_data	1.15741E-05	1317104	15.24425926	100	13171.04	13171.04	
TMS to PS	current_traffic_static_data	1.90781E-07	763847840	145.7279915	100	7638478.4	7638478.4	

**Table 6.3-3 Wireline Data Loading Analysis, 2012, Urbansville**

Wireline Link	Message	Frequency (/sec)	Message Size (bits)	Ave. Link Load (b/s)	Latency (sec)	Peak Link Load (b/s)	Max. Load (b/s)	Link Type
TMS to PS	traffic_data_for_deployment	1.15741E-05	83874885	970.7741283	10	8387488.468	8387488.468	
<b>TMS to PS Total</b>				1131.74668		16039398.19	16039398.19	DS3
TMS to RS	ahs_control_data_changes	2.31481E-05	4114	0.095231481	0.1	41140	41140	
TMS to RS	indicator_control_data_for_highways	1	173674	173674	0.1	1736740	1736740	
TMS to RS	indicator_control_data_for_roads	1	3561234	3561234	0.1	35612340	35612340	
TMS to RS	indicator_control_monitoring_data_for_highways	1	173674	173674	0.1	1736740	1736740	
TMS to RS	indicator_control_monitoring_data_for_roads	1	3561234	3561234	0.1	35612340	35612340	
TMS to RS	vehicle_sign_data	2	901146	1802292	0.1	9011460	9011460	
<b>TMS to RS Total</b>				9272108.095		83750760	83750760	DS3
TMS to TAS	toll_price_changes_request	0.001111111	914	1.015555556	0.1	9140	9140	
<b>TMS to TAS Total</b>				1.015555556		9140	9140	DS0
TMS to TRMS	parking_lot_charge_request	0.003333333	26	0.086666667	0.1	260	260	
TMS to TRMS	prediction_data	0.001111111	400634	445.1488889	10	40063.4	40063.4	
TMS to TRMS	toll_price_request	0.003333333	26	0.086666667	0.1	260	260	

**Table 6.3-3 Wireline Data Loading Analysis, 2012, Urbansville**

Wireline Link	Message	Frequency (/sec)	Message Size (bits)	Ave. Link Load (b/s)	Latency (sec)	Peak Link Load (b/s)	Max. Load (b/s)	Link Type
TMS to TRMS	transit_conditions_demand_request	0.003333333	34	0.113333333	0.1	340	340	
TMS to TRMS	transit_fare_request	0.003333333	26	0.086666667	0.1	260	260	
TMS to TRMS	transit_services_changes_request	0.001111111	8210	9.122222222	0.1	82100	82100	
TMS to TRMS	transit_services_demand_request	0.003333333	562	1.873333333	0.1	5620	5620	
<b>TMS to TRMS Total</b>				456.5177778		128903.4	128903.4	DS1
Toll Service Provider to TAS	ftsp_confirm_advanced_toll	0.036529774	34	1.242012326	0.1	340	340	
Toll Service Provider to TAS	ftsp_toll_price_changes_response	3.80267E-07	34	1.29291E-05	0.1	340	340	
Toll Service Provider to TAS	ftsp_toll_price_data	0.000115741	274	0.031712963	0.1	2740	2740	
<b>Toll Service Provider to TAS Total</b>				1.273738218		3420	3420	DS0
Traffic Operations Personnel to EMMS	ftop_pollution_data_information_request	0.000277778	50	0.013888889	0.1	500	500	
Traffic Operations Personnel to EMMS	ftop_pollution_parameter_updates	0.000277778	274	0.076111111	0.1	2740	2740	
<b>Traffic Operations Personnel to EMMS Total</b>				0.09		3240	3240	DS0
Transit Maintenance Personnel to TRMS	ftmp_transit_vehicle_maintenance_updates	1.15741E-05	530	0.006134259	0.1	5300	5300	
<b>Transit Maintenance Personnel to TRMS Total</b>				0.006134259		5300	5300	DS0

**Table 6.3-3 Wireline Data Loading Analysis, 2012, Urbansville**

Wireline Link	Message	Frequency (/sec)	Message Size (bits)	Ave. Link Load (b/s)	Latency (sec)	Peak Link Load (b/s)	Max. Load (b/s)	Link Type
Transit System Operators to TRMS	ftso_emergency_request_acknowledge	0.60792	34	20.66928	0.1	340	340	
Transit System Operators to TRMS	ftso_fare_updates	3.80267E-07	274	0.000104193	0.1	2740	2740	
Transit System Operators to TRMS	ftso_media_parameter_request	1.15741E-05	34	0.000393519	0.1	340	340	
Transit System Operators to TRMS	ftso_media_parameter_updates	1.15741E-05	274	0.003171296	0.1	2740	2740	
Transit System Operators to TRMS	ftso_request_fare_output	3.47222E-05	34	0.001180556	0.1	340	340	
Transit System Operators to TRMS	ftso_security_action	4.63E-06	146	0.000675922	0.1	1460	1460	
<b>Transit System Operators to TRMS Total</b>				20.67480549		7960	7960	DS0
Transportation Planners to PS	ftp_evaluation_request	1.15741E-05	146	0.001689815	0.1	1460	1460	
Transportation Planners to PS	ftp_export_request	1.15741E-05	50	0.000578704	0.1	500	500	
Transportation Planners to PS	ftp_generation_request	1.15741E-05	2066	0.023912037	0.1	20660	20660	
Transportation Planners to PS	ftp_import_request	1.15741E-05	82	0.000949074	0.1	820	820	
Transportation Planners to PS	ftp_output_request	1.15741E-05	82	0.000949074	0.1	820	820	
Transportation Planners to PS	ftp_parameters	1.15741E-05	274	0.003171296	0.1	2740	2740	
Transportation Planners to PS	ftp_request_documentation	1.15741E-05	82	0.000949074	0.1	820	820	

**Table 6.3-3 Wireline Data Loading Analysis, 2012, Urbansville**

Wireline Link	Message	Frequency (/sec)	Message Size (bits)	Ave. Link Load (b/s)	Latency (sec)	Peak Link Load (b/s)	Max. Load (b/s)	Link Type
Transportation Planners to PS	ftp_request_link_data	1.15741E-05	50	0.000578704	0.1	500	500	
Transportation Planners to PS	ftp_simulation_request	1.15741E-05	34	0.000393519	0.1	340	340	
Transportation Planners to PS	ftp_static_data	1.15741E-05	530	0.006134259	0.1	5300	5300	
Transportation Planners to PS	ftp_traffic_data_request	1.15741E-05	34	0.000393519	0.1	340	340	
Transportation Planners to PS	ftp_update_link_data	1.15741E-05	530	0.006134259	0.1	5300	5300	
<b>Transportation Planners to PS Total</b>				0.045833333		39600	39600	DS0
TRMS to EM	transit_coordination_data	0.000833333	40994	34.16166667	10	4099.4	4099.4	
TRMS to EM	transit_emergency_data	0.60814766	178	108.2502834	0.1	1780	1780	
TRMS to EM	transit_incident_details	4.62963E-06	178	0.000824074	0.1	1780	1780	
<b>TRMS to EM Total</b>				142.4127742		7659.4	7659.4	DS0
TRMS to Enforcement Agency	tea_fare_collection_roadside_violation_data	178.8	274	48991.2	0.1	2740	48991.2	
TRMS to Enforcement Agency	tea_fare_collection_vehicle_violation_data	178.8	274	48991.2	0.1	2740	48991.2	
TRMS to Enforcement Agency	tea_fare_payment_violation_data	3.973788156	274	1088.817955	0.1	2740	2740	
<b>TRMS to Enforcement Agency Total</b>				99071.21795		8220	100722.4	DS1

**Table 6.3-3 Wireline Data Loading Analysis, 2012, Urbansville**

Wireline Link	Message	Frequency (/sec)	Message Size (bits)	Ave. Link Load (b/s)	Latency (sec)	Peak Link Load (b/s)	Max. Load (b/s)	Link Type
TRMS to Financial Institution	tfi_fare_payment_violator_data	0.496666667	2066	1026.113333	0.1	20660	20660	
TRMS to Financial Institution	tfi_other_services_payment_request	11.92	274	3266.08	0.1	2740	3266.08	
TRMS to Financial Institution	tfi_request_fare_payment	1.15741E-05	274	0.003171296	0.1	2740	2740	
<b>TRMS to Financial Institution Total</b>				4292.196505		26140	26666.08	DS0
TRMS to Intermodal Transportation Service Provider	titsp_transit_arrival_changes	596	4114	2451944	0.1	41140	2451944	
TRMS to Intermodal Transportation Service Provider	titsp_transit_arrival_deviations	596	4114	2451944	0.1	41140	2451944	
TRMS to Intermodal Transportation Service Provider	titsp_transit_service_data	0.000277778	8192018	2275.560556	1	8192018	8192018	
<b>TRMS to Intermodal Transportation Service Provider Total</b>				4906163.561		8274298	13095906	DS3
TRMS to ISP	advanced_other_fares_confirm	407.4535467	410	167055.9541	0.1	4100	167055.9541	
TRMS to ISP	advanced_tolls_and_charges_vehicle_request	298	738	219924	0.1	7380	219924	
TRMS to ISP	advanced_traveler_fares_confirm	105.2396389	250	26309.90972	0.1	2500	26309.90972	
TRMS to ISP	paratransit_personal_schedule	15.78594583	418	6598.525358	0.1	4180	6598.525358	
TRMS to ISP	transit_deviation_data_received	596	26	15496	0.1	260	15496	
TRMS to ISP	transit_media_emergency_information	0.60814766	2330	1416.984047	0.1	23300	23300	



**Table 6.3-3 Wireline Data Loading Analysis, 2012, Urbansville**

Wireline Link	Message	Frequency (/sec)	Message Size (bits)	Ave. Link Load (b/s)	Latency (sec)	Peak Link Load (b/s)	Max. Load (b/s)	Link Type
TRMS to ISP	transit_media_incident_informatio n	4.62963E-06	4378	0.020268519	0.1	43780	43780	
TRMS to ISP	transit_services_for_advisory_data	0.003333333	172354	574.5133333	0.1	1723540	1723540	
TRMS to ISP	transit_services_for_guidance	0.003333333	2530	8.433333333	0.1	25300	25300	
TRMS to ISP	transit_user_payments_transactio ns	11.92	1042	12420.64	0.1	10420	12420.64	
TRMS to ISP	transit_vehicle_deviations_details	1.49	398502.8	593769.172	0.1	3985028	3985028	
<b>TRMS to ISP Total</b>				1043574.152		5829788	6248753.029	DS3
TRMS to Other TRM	totrm_transit_services	0.000277778	81920018	22755.56056	60	1365333.633	1365333.633	
<b>TRMS to Other TRM Total</b>				22755.56056		1365333.633	1365333.633	DS1
TRMS to PIAS	transit_services_for_portables	2.192492477	2530	5547.005966	0.1	25300	25300	
<b>TRMS to PIAS Total</b>				5547.005966		25300	25300	DS0
TRMS to PMS	parking_lot_transit_response	0.005555556	34	0.188888889	0.1	340	340	
<b>TRMS to PMS Total</b>				0.188888889		340	340	DS0
TRMS to PS	financial_reports	1.65344E-06	24577818	40.63792659	60	409630.3	409630.3	
TRMS to PS	transit_passenger_operational_dat a	1.15741E-05	26.676481	0.000308756	0.1	266.7648148	266.7648148	

**Table 6.3-3 Wireline Data Loading Analysis, 2012, Urbansville**

Wireline Link	Message	Frequency (/sec)	Message Size (bits)	Ave. Link Load (b/s)	Latency (sec)	Peak Link Load (b/s)	Max. Load (b/s)	Link Type
TRMS to PS	transit_services_for_deployment	1.15741E-05	172354	1.994837963	1	172354	172354	
<b>TRMS to PS Total</b>				42.63307331		582251.0648	582251.0648	DS1
TRMS to RTS	confirm_roadside_fare_payment	1788	26	46488	0.1	260	46488	
TRMS to RTS	other_services_roadside_response	5.96	2418	14411.28	0.1	24180	24180	
TRMS to RTS	request_transit_user_image	3.973788156	82	325.8506288	0.1	820	820	
TRMS to RTS	transit_roadside_fare_data	3.80267E-07	922	0.000350607	0.1	9220	9220	
TRMS to RTS	transit_roadside_fare_payment_debited	1788	26	46488	0.1	260	46488	
TRMS to RTS	transit_roadside_fare_payment_request	1788	34	60792	0.1	340	60792	
TRMS to RTS	transit_services_for_kiosks	2.192492477	2378	5213.74711	0.1	23780	23780	
TRMS to RTS	transit_services_for_roadside_fares	0.000289352	16826	4.868634259	0.1	168260	168260	
TRMS to RTS	transit_services_for_travelers	0.13391744	2530	338.8111244	0.1	25300	25300	
TRMS to RTS	transit_vehicle_arrival_time	0.111111111	66	7.333333333	0.1	660	660	
TRMS to RTS	transit_vehicle_user_data	13.33	106	1412.98	0.1	1060	1412.98	
<b>TRMS to RTS Total</b>				175482.8712		254140	407400.98	DS1

**Table 6.3-3 Wireline Data Loading Analysis, 2012, Urbansville**

Wireline Link	Message	Frequency (/sec)	Message Size (bits)	Ave. Link Load (b/s)	Latency (sec)	Peak Link Load (b/s)	Max. Load (b/s)	Link Type
TRMS to Secure Area Environment	tsa_broadcast_message	4.62963E-06	402	0.001861111	0.1	4020	4020	
TRMS to Secure Area Environment	tsa_panuc_button_acknowledge	4.62963E-06	82	0.00037963	0.1	820	820	
<b>TRMS to Secure Area Environment Total</b>				0.002240741		4840	4840	DS0
TRMS to TMS	parking_lot_charge_details	0.003333333	322	1.073333333	0.1	3220	3220	
TRMS to TMS	toll_price_details	0.003333333	914	3.046666667	0.1	9140	9140	
TRMS to TMS	transit_fare_details	0.003333333	17306	57.68666667	0.1	173060	173060	
TRMS to TMS	transit_highway_overall_priority		596	26	15496	0.1	260	15496
TRMS to TMS	transit_ramp_overall_priority		596	146	87016	0.1	1460	87016
TRMS to TMS	transit_road_overall_priority		596	26	15496	0.1	260	15496
TRMS to TMS	transit_running_data_for_demand	0.003333333	398270.8	1327.569333	1	398270.8	398270.8	
TRMS to TMS	transit_services_changes_response	0.001111111	34	0.037777778	0.1	340	340	
TRMS to TMS	transit_services_for_demand	0.003333333	172386	574.62	1	172386	172386	
<b>TRMS to TMS Total</b>				119972.0338		758396.8	874424.8	DS1
TRMS to Transit Maintenance Personnel	ttmp_work_schedule	0.001241667	8210	10.19408333	0.1	82100	82100	

**Table 6.3-3 Wireline Data Loading Analysis, 2012, Urbansville**

Wireline Link	Message	Frequency (/sec)	Message Size (bits)	Ave. Link Load (b/s)	Latency (sec)	Peak Link Load (b/s)	Max. Load (b/s)	Link Type
<b>TRMS to Transit Maintenance Personnel Total</b>				10.19408333		82100	82100	DS1
TRMS to Transit System Operators	ttso_emergency_request	0.000833333	530	0.441666667	0.1	5300	5300	
TRMS to Transit System Operators	ttso_media_parameters	1.15741E-05	8210	0.095023148	0.1	82100	82100	
TRMS to Transit System Operators	ttso_potential_incidents_alarm	0.000833333	530	0.441666667	0.1	5300	5300	
TRMS to Transit System Operators	ttso_potential_security_problem	0.000833333	530	0.441666667	0.1	5300	5300	
TRMS to Transit System Operators	ttso_transaction_reports	1.15741E-05	81920018	948.1483565	100	819200.18	819200.18	
TRMS to Transit System Operators	ttso_transit_fare_output	3.47222E-05	8210	0.285069444	0.1	82100	82100	
<b>TRMS to Transit System Operators Total</b>				949.8534491		999300.18	999300.18	DS1
Weather Service to ISP	From_Weather_Service	0.001111111	1042	1.157777778	0.1	10420	10420	
Weather Service to ISP	fws_current_weather	0.000277778	530	0.147222222	0.1	5300	5300	
Weather Service to ISP	fws_predicted_weather	0.000277778	530	0.147222222	0.1	5300	5300	
<b>Weather Service to ISP Total</b>				1.452222222		21020	21020	DS0
Weather Service to TMS	From_Weather_Service	0.001111111	1042	1.157777778	0.1	10420	10420	
Weather Service to TMS	fws_current_weather	0.000277778	530	0.147222222	0.1	5300	5300	

**Table 6.3-3 Wireline Data Loading Analysis, 2012, Urbansville**

Wireline Link	Message	Frequency (/sec)	Message Size (bits)	Ave. Link Load (b/s)	Latency (sec)	Peak Link Load (b/s)	Max. Load (b/s)	Link Type
Weather Service to TMS	fws_predicted_weather	0.000277778	530	0.147222222	0.1	5300	5300	
<b>Weather Service to TMS Total</b>				1.452222222		21020	21020	DS0
Yellow Pages Service Providers to ISP	fypsp_request_provider_registration	3.80267E-07	50	1.90134E-05	0.1	500	500	
Yellow Pages Service Providers to ISP	fypsp_transaction_confirmation	105.2396389	26	2736.230611	0.1	260	2736.230611	
Yellow Pages Service Providers to ISP	fypsp_yellow_pages_data	0.003333333	8192018	27306.72667	10	819201.8	819201.8	
<b>Yellow Pages Service Providers to ISP Total</b>				30042.9573		819961.8	822438.0306	DS1

## **6.4 Analysis of the Data Loading Results**

The general trends of the data loads are discussed in this section.

### **6.4.1 u1t Interface**

In 1997 Urbansville, the transit and CVO-local user service groups are the largest users of data in the forward direction, with the other groups far below. In the reverse direction CVO-local is again the largest load, with smaller loads from transit and probes groups.

In 1997 Thruville, the transit and CVO-local groups provide the largest loads in the forward direction, with the others far below. In the reverse direction CVO-local is alone as the largest load, with probes, transit, and emergency having lower, but significant loads.

In 2002 Urbansville, CVO-local, transit, and private vehicles contribute the largest loads, with the others far below in the forward direction. In the reverse direction, CVO-local has the highest load with transit about one-half the load. The others are well down.

In 2002 Thruville, CVO-local and transit have the highest loads by a wide margin in the forward direction, with CVO-local contributing the largest load in the reverse direction.

In 2002 Mountainville, CVO-local is the largest load with all other users far below it in the forward direction. In the reverse direction CVO-local is alone the largest contributor, with all others well down.

In 2012 Urbansville, the private vehicles and CVO-local contribute the highest data loads, with transit at about one-half of their level. The others are well down. In the reverse direction, CVO-local is at the lead again, with transit at about one-third its level with private vehicle a bit lower.

In 2012 Thruville, CVO-local is largest in the forward direction, with transit at about one-half its level. In the reverse direction, CVO-local is the largest load with transit next at about one-third its level. Private vehicles, probes, and emergency all contribute significant loads.

In 2012 Mountainville, CVO-local has the highest load, with private vehicle and transit somewhat lower in the forward direction. In the reverse direction, CVO-local has the highest load with transit in second place at about one-fourth its level.

In each of the u1t scenarios and time frames studied, the forward direction data load is always higher than the reverse direction load, by a factor of two to three. The consistent users of the reverse direction are CVO and transit.

### **6.4.2 u1b Interface**

The total aggregate data rate for a single broadcast transmitter sending the entire set of data from a region is 5,651 bps. This rate is easily achieved with any of the second generation broadcast subcarrier systems (see Section 7). If the data from the region is split between geographically-separated broadcast transmitters, the data rate on any individual transmitter would naturally be reduced.

### **6.4.3 u2 Interface**

Due to the short propagation range of these systems, which enables fairly high data rates, their limited (by definition) coverage, and their layout to cover directly one or more lanes, communication capacity and performance are not issues. Any reasonably well designed multiple access scheme would handle the multiple user within coverage of a given beacon. Various commercial solutions are currently available and are deployed in selected locales. There are, however, other issues of technical feasibility if these systems are considered for use to provide wide area wireless coverage, through wide spread deployment. These issues are discussed in Section 7 and Appendix G.

### **6.4.4 u3 Interface**

The u3 interface, used for AHS applications, is still in the research stage and is covered in another program. Since this interface would use very-short-range communications over dedicated spectrum, there are no ITS communications system design issues that would not be addressed while conducting the AHS research independently.

### **6.4.5 Wireline Interface**

There was a total of 140 wireline links studied, including links between subsystems, and to/from terminators. It was concluded that 60% of these links could be carried over 56 Kbps links. An additional 25% of the links could be carried over 1.5 Mbps links. The remaining links have aggregate data rates as high as 200 Mbps (i.e., for the ISP to RTS, and Secure Area Environment to TRMS links). In the case of a distributed subsystem, such as RS, the aggregate data load is the total load for all elements of the subsystem, where in a distribution network the total aggregate load is seen (such as near the TMS in the RS to TMS link case). Thus, the vast majority of these remaining links (particularly within a network) can be carried over 45 Mbps links. The wireline loads determined can easily be carried over numerous existing wireline communications options.

## 7. ASSESSMENT OF COMMUNICATION SYSTEMS AND TECHNOLOGIES

### 7.1 Introduction

In this section, a hot, contentious area is entered, that is, determining which communication systems are best suited for the ITS applications. It must be established at the outset that the intent of this section is **not** to recommend any “winning” systems or technologies – on the contrary, it can be stated *a priori* that all so-called winning solutions are at most temporarily such, heroes and victims of an unstoppable technology evolution that makes today’s best into tomorrow’s underdogs.

The intent of this section is solely to provide the reader with a characterization of today’s candidate technologies that is as complete as possible, and also to offer a glimpse into the systems that loom on the horizon. Hopefully, this section will provide the implementors with a broad perspective of existing technologies. However, this section does not constitute in any way a technology study for any particular scenario. In particular, it does not account for any political, institutional, jurisdictional, budgetary or other similar constraints.

This section contains a broad analysis, review, and assessment of the various communication technologies that are applicable to the ITS architecture. The results of this assessment will lead to recommendations incorporated in the Physical Architecture definition that will be manifested, for example, in the Architecture Interconnect Specifications (AIS). The analyses herein lead naturally into the more detailed communication simulation issues addressed in Section 8 which is more focused on the simulation of a specific wireless system.<sup>1</sup>

This section begins with the review of the communication analysis objectives and methodology. It then discusses the assumptions underlying the systems and technologies selected for analysis – namely the use of shared infrastructure wherever and whenever possible.

---

<sup>1</sup> For practical considerations, the wireless analysis/simulation effort has to be constrained to already standardized open systems. Since CDPD is the only fully standardized open-system for data communications over cellular (in the U.S. or abroad), with the added advantage of being already in the deployment stage, it will be analyzed in depth in Section 8 — this does not imply, however, any commitment to CDPD as the ITS wide-area delivery platform.



### **7.1.1 Objectives of the Technology Assessment**

The main goal of the ITS communication systems technology assessment is to aid in selecting the best communication architecture (framework of system or systems, configurations, technologies, and techniques) that meet the objectives of the overall ITS system architecture. A secondary objective is to provide information for the implementors (local DOT's, etc.) to best match their needs to the capabilities of the available systems - subject to specific budgetary constraints.

Through communication systems analysis and a modicum of modeling and simulation, as appropriate, it will be ascertained how the communications element or "layer" of the system architecture satisfies the requirements at all stages of deployment, especially for the 1997, 2002, and 2012 time frames.

### **7.1.2 Underlying Assumptions**

The strategy for assessing the communication layer of the ITS system architecture reflects both the Joint Team's architecture development philosophy and methodology. The communications layer provides the information transfer (data flow) that is required by the transportation layer to implement the desired user services. This communication component of the architecture must be technically and economically feasible as well as sensitive to the potential institutional and regulatory barriers. To fulfill this vision, the communication component has to emerge from current communications infrastructures, and progress in a manner consistent with the predicted evolution of telecommunication systems.

Two main principles will guide the evaluation efforts:

1. Extensive use of available technology whenever and wherever possible, and shared use of emerging infrastructures in order to minimize the costs directly attributable to ITS; and
2. Monitoring ongoing field trials and tests, as well as other FHWA/Government sponsored projects/studies (e.g., AHS Program).

Over the next twenty years, many new communications technologies, from multiple access to transport to switching, will be introduced at a rapid pace to support the demands of our information age. These technologies will offer extensive opportunities to handle the ITS user services and should be exploited fully. The technology projection displayed in Table 7.1-1 identifies the predicted availability of certain communication technologies and infrastructures to the year 2012.

In addition to the tremendous financial investment in the existing/emerging communication infrastructures (~\$20 billion in the cellular infrastructure alone until 1995), an equally large amount of time and effort has been spent in developing standards to allow inter-operability and inter-connectivity among these systems. In the process, an extensive practical and theoretical knowledge base has been developed (reviewed in Section 7.5), that greatly expands upon the Phase I Technology Assessment in the Rockwell Team's *Physical Architecture* document. This broad assessment of communication technologies applicable to ITS includes in-depth, quantitative analyses. These analyses will be augmented in Section 8 with detailed simulations that examine a specific wide area technology deemed well suited for adoption as a service delivery medium within the National ITS Architecture.

### **7.1.3 Section Structure**

Section 7.2 classifies the communication systems to be assessed into Wireless, both Wide-Area and Short-Range, and Wireline.

Section 7.3 analyzes the impact of non-ITS applications on the ITS service offerings assuming the use of shared media.

Section 7.4 analyzes the increasingly important role of protocols and inter-networking issues. It is important to understand that in a heterogeneous communications network (that at least encompasses both wireless and wireline components), it is the inter-networking functions (INF) that guarantee the system's throughput.

Section 7.5 presents the Technology Assessment arranged again into wireline and wireless systems, with substantially more emphasis on the wireless systems. The latter are classified and analyzed into wireless metropolitan area networks (MAN's), cell-based land-mobile systems, satellite-mobile systems, and broadcast systems.

Section 7.6 summarizes the Technology Assessment and presents an analysis of the systems side by side to facilitate comparison. The objective, once again, is not to recommend any specific solution, but to facilitate the implementors task of selecting the best solution for their identified problems and available budgets by having, in a single place, as complete a characterization of the systems as feasible at this time.

**Table 7.1-1 Communications Technology Projections to the Year 2012**

Technologies	1992	1997	2002	2012
Wireless Access	FDMA Analog	TDMA/CDMA Digital	CDMA/TDMA Digital	CDMA/TDMA Digital
Wireless Capacity	Moderate	High (3-5x AMPS)	High (5-10x AMPS)	High (10-15x AMPS)
Wireless Signal Coverage	All Urban, Most Inter-Urban, Some Rural	All Urban and Inter-Urban, Most Rural	All Urban and Inter-Urban All inhabited Rural	Ubiquitous
Wireless Media				Transparent, Hybrid Terrestrial Satellite
• Terrestrial:	Most Macro	Full Macro, Initial Micro	Full Macro, Most Micro	Integrated Macro/Micro
• Satellite:	Limited GEO	Several GEO, Initial LEO	Full GEO, Partial LEO	Full GEO/ Full LEO
Wireline Availability	Widespread Copper Limited Fiber for LAN's and Backbone	Fiber Backbone with Copper Drops Very Limited Hybrid Fiber-Coax	Very Limited Fiber to Curb Some Hybrid Fiber-Coax	Partial Fiber to Curb Limited Fiber to Home
Transfer Mode	Full Circuit-Switching Packet-Switching Initial Frame-Relaying	Partial Frame-Relaying Very Limited Asynchronous Transfer Mode (ATM)	Most Frame-Relaying Initial Fast-Packet Switching Partial ATM	Most Fast-Packet Switching Most ATM
Data Protocol	X.25, X.21	Frame-Relay ATM	Frame-Relay ATM	Mostly ATM
Transport Network Characteristics	Service Dependent Disconnected LAN's Slow Speed Interconnection	Initial Service-Independent Initial LAN Connectivity through Metropolitan Area Networks (MAN)	Partial Service-Independent Partial MAN's	Widespread Service Integrated Broadband Network—B-ISDN Most Service Independent
Intelligent Network Characteristics	Partial Wireline Support: • Number Translation	Most Wireline Support Partial Wireless Support • Mobility Services (Personal, Terminal)	Full Wireline Support Most Wireless Support	Fully Integrated Wireline/Wireless Support • Seamless Operation • Multi-Mode Terminal • Profile Portability • Dynamic Resource Allocation • Information Format Adaptation

## **7.2 Communication Systems Analysis and Assessment Approach**

The communication systems/technologies assessment will be presented in two segments – wireless and wireline –reflecting the nature of the communication infrastructure. End-to-end performance, however, warrants looking at the ensemble behavior, not only of the wireless and wireline components of the communication layer, but also at the switching/routing elements. It should also be kept in mind, that as wireless systems become more prevalent, some distinctions in use will vanish.

### **7.2.1 Wireless Communication Systems Analysis**

The wireless systems to be considered in an ITS context fall naturally into two different classes having to do with the intended range for information dissemination/collection: wide-area and short-range communication systems.

#### **7.2.1.1 *Wide-Area Communication Systems***

Wireless communication is a broad and rapidly expanding field. The ITS architecture is most concerned with wireless *data* communication. Unfortunately, wireless data is a relatively new field, still with a number of proprietary systems. Moreover, some of the new wireless telecommunications standards that are being adopted for voice (e.g., CDMA and A-TDMA), have data service proposals that are in their infancy. The combination of breadth of communication system possibilities, new technology and proprietary systems, makes the analysis effort a rather daunting task. The analysis will therefore tackle different systems/technologies at different levels of depth and detail, ranging from very detailed, state-of-the-art simulation, to cursory quantitative examination of technical information available, even to the more risky anticipation of standards work results. Of course, the systems/technologies that are of most interest from a National ITS Architecture standpoint get the most detailed analytical treatment.

The systems to be analyzed are: wireless MAN (Metropolitan Area Network) systems targeting stationary users, land-mobile and satellite-mobile cell-based systems, meteor scatter systems (the “poor man’s” satellite), and broadcast systems. A wide-area beacon-based “solution” is also looked into.

#### **7.2.1.2 *Short-Range Communications***

In Phase I, Vehicle-to-Vehicle Communications (VtoVC) and Dedicated Short Range Communications (DSRC), were only briefly analyzed. In Phase II, some detail has been added based upon work being done in the DSRC area at the standards bodies.

Several subsidized and independent studies are underway in the VtoVC area, some in the U.S. and others in Europe. A review of the most promising candidates from a national U.S. perspective needs to be performed. Any ITS architectural implications regarding the adoption of certain solutions should also be identified. The role of the National ITS Architecture in the definition of VtoVC has been mainly of monitoring the progress in the area.

##### **7.2.1.2.1 Dedicated Short Range (formerly Vehicle-to-Roadside) Communications**

The applications for which the Dedicated Short Range (DSRC) wireless solution is appropriate have already been clearly identified in the *Physical Architecture* document. They include toll collection, parking fee collection, roadside safety inspection, and credentials pre-clearance.

The short range communication systems differ intrinsically from wide area wireless systems such as cellular. The former benefit from being in a confined geographical area (few hundred feet at most), and

therefore are less susceptible to multi-user, multi-base station interference than systems that cover a whole metropolitan area. The key issues center around the adequacy of the different systems proposed (IR, RF Active, RF Passive) to accommodate the user requirements, and their flexibility and expandability towards the goal of national compatibility.

#### 7.2.1.2.2 Vehicle-to-Vehicle Communications

Given that AHS is the subject of an ongoing, parallel study that is still in its initial stages, the Joint Team will restrict its analysis to a review of proposed interfaces and communication systems, an acknowledgment of the importance of AHS and its impact on the National ITS architecture. The objective is to insure inter-operability, especially concerning vehicle-to-vehicle and vehicle-to-roadside communications (VtoVC and DSRC), and that the National ITS Architecture does not inadvertently close any paths for the AHS Consortium to investigate.

### 7.2.2 Wireline Communication Analysis

Whereas wireless technologies are quickly evolving in a heated competitive environment, a host of wireline technologies have become generally accepted, and consequently broadly modeled by a host of general purpose simulation packages (e.g., OPNET, COMNET, BONES). These wireline technologies and techniques, however, span a great deal of range in capability, cost, and relative maturity (e.g., fiber versus coaxial versus twisted-pair; ISDN versus frame relay versus FDDI versus ATM). The wireline infrastructure to support ITS applications can, therefore, be an arena of much selection and variability depending on the disparate transportation needs, objectives, and budget of the many jurisdictions.

In Phase I, it was concluded that the wireline portion of the communication systems supporting ITS will not constitute the communications bottleneck. (The Phase I wireline simulation results are included in Section 8 for the reader's convenience.) In fact, through proper design, and given the many alternatives available, the capacity and/or throughput of wireline systems can be made to meet the users' requirements (with any desired margins) satisfying any least cost criterion. Thus, the emphasis in Phase II is on communication systems and protocols that could not be analyzed in Phase I due to lack of resources and because models were not available.

### 7.2.3 End-to-End Communication Analysis

The above separate analysis of the wireline and wireless components of the communications infrastructure needs to be combined with the objective of assessing the end-to-end system performance. Referring back to Figure 3.2-3 depicting the AID-level 0, end-to-end performance from an ITS service perspective can be viewed as comprising: 1.) communication system performance (wireless and wireline segments connecting two AID subsystems as well as the switching/routing elements), and 2.) the performance of the "transportation layer" subsystems themselves (their processing time, any data base access time, etc.). The overall end-to-end ITS service requirements are elucidated in the *Mission Definition* document and are derived, in many cases, from inexact human factors related to ITS service acceptance.

Since the performance of any ITS subsystem is a moving target, driven primarily by the stakeholders' budgetary constraints, the focus here and in Section 8 will be only on the telecommunication segment (wireless and wireline). In the end, it will be seen that the communication layer implementations considered will not place any undue constraint or limitation on the provision of the ITS services.

### 7.3 Non-ITS Applications and Their Impact

When obtaining the communication systems' end-to-end performance for any deployed infrastructure with other users, it is intuitive that the traffic generated by non-ITS users will have an impact on the ITS performance.

To illustrate, we use CDPD here as an example. If the ITS data loads can be accommodated on one CDPD channel per sector (the so called minimal deployment even out to 20 years), and if the non-ITS traffic is a few times that of ITS, the total traffic may not be accommodated on only one channel.

On the other hand, the crux, as well as the advantage of cell based systems, is that the solution for the higher traffic is simply to deploy more (in this case CDPD) channels as needed. (Loaded data channels are more profitable than voice to the carrier.) In fact, the voice demand leads the way to the deployment of new cells and splitting the present cells into smaller and smaller ones, that continue to have more or less the same load. CDPD deployment (as that of any other overlay system) follows that of voice.<sup>2</sup>

The difficulty in assessing the effect of non-ITS users resides in the characterization of the traffic they generate. After long discussions both inside the Team and with wireless data experts in various companies, it was agreed that a few non-ITS applications are "promising":

- 1) Credit Card/Transaction Authorization and Fixed/Mobile POS
  - Taxis
  - Food Delivery
  - Door-to-Door Sales
  - Landscaping, Pool care, Snow Removal, etc.
  - Gas Stations
  - Fast Food
  - Other Retail
- 2) Telemetry
  - Oil, gas, water and power monitoring
  - Oil, gas and water well production monitoring and control
  - Oil and gas pipeline monitoring and control
  - Electric power demand monitoring
  - Storage tank level monitoring
  - Pollution and noise level monitoring
  - Vending machine remote inventory control and loss management
- 3) Field Service (Appliances, Cable, Utilities, High Tech, Office Equipment)
  - Job dispatch
  - Information access
  - Reporting
- 4) Health Care (Visiting Nurses, House Calls)

---

<sup>2</sup> In Phase I, an analysis was made regarding the case of one reserved CDPD channel plus another one dynamically assigned as a function of availability and demand. In Phase II the case was considered of one reserved CDPD channel, as well as a totally dynamic solution for the CDPD problem with no reserved channels.

- Job dispatch
  - Information access
  - Reporting
- 5) Field Sale
- Catalog/Information access
  - Order placing
- 6) Public Safety
- NCIC inquiry
  - State and Local data base access
  - Incident and shift reporting
- 7) Security
- Keycard access
  - Commercial Alarms
- 8) Mobile Office
- LAN access: File synchronization, file transfer, data base access, calendar update, etc.
  - Internet access
  - E-mail
- 9) Remote Access
- Internet access
  - E-mail

Looking at the above list, which does not presume to cover all the upcoming uses of wireless data access, two distinct classes of applications can be observed: one corresponding to occasional, bursty transactions, including all entries 1) to 7), and another corresponding to a more or less continuous use of the system, with longer “transactions”, constituting a traffic background for the first class of applications.

At this point, in order to get some feeling for the non-ITS traffic to be expected, it becomes necessary to predict the number of users in each category. This is obviously the subject of much heated debate with predictions covering the whole spectrum, depending on how optimistic, realistic, or pessimistic the authors want to be.

Based upon Market Research information GTE obtained from a few, well respected companies, and some internal market projections, the numbers of wireless data users for the year 2002, shown in Table 7.3-1 and Figure 7.3-1, were settled upon. Those figures are nothing more than just another projection. It will later be shown however, that it is a rather sensible projection.

### **7.3.1 Non-ITS Wireless Data Market Projections for 2002**

A slightly different classification will be used in coming up with projections for the number of users for each type of applications.

**Table 7.3-1 Wireless Data Market Projections (from External and GTE Market Studies)**

Number of Wireless Data Users (x1000)	1994	1995	1996	1997	1998	1999	2000	2001	2002
Public Safety	90	111	132	160	207	273	367	498	677
Field Service	171	250	386	594	875	1229	1593	1900	2062
Transportation	145	198	291	425	614	865	1139	1372	1488
Field Sales	49	120	213	369	614	934	1293	1611	1806
Telemetry	1	9	39	92	192	389	758	1400	2395
Transactions/POS	1	8	29	68	146	282	461	622	671
Mobile Professional Sales (excluding Field Sales)	37	74	135	225	362	540	725	851	874
Mobile Professional Non-Sales	5	10	50	219	742	1886	3537	4893	4906
Public	1	4	15	55	189	587	1590	3661	6957
Total	500	783	1291	2207	3942	6984	11461	16808	21837

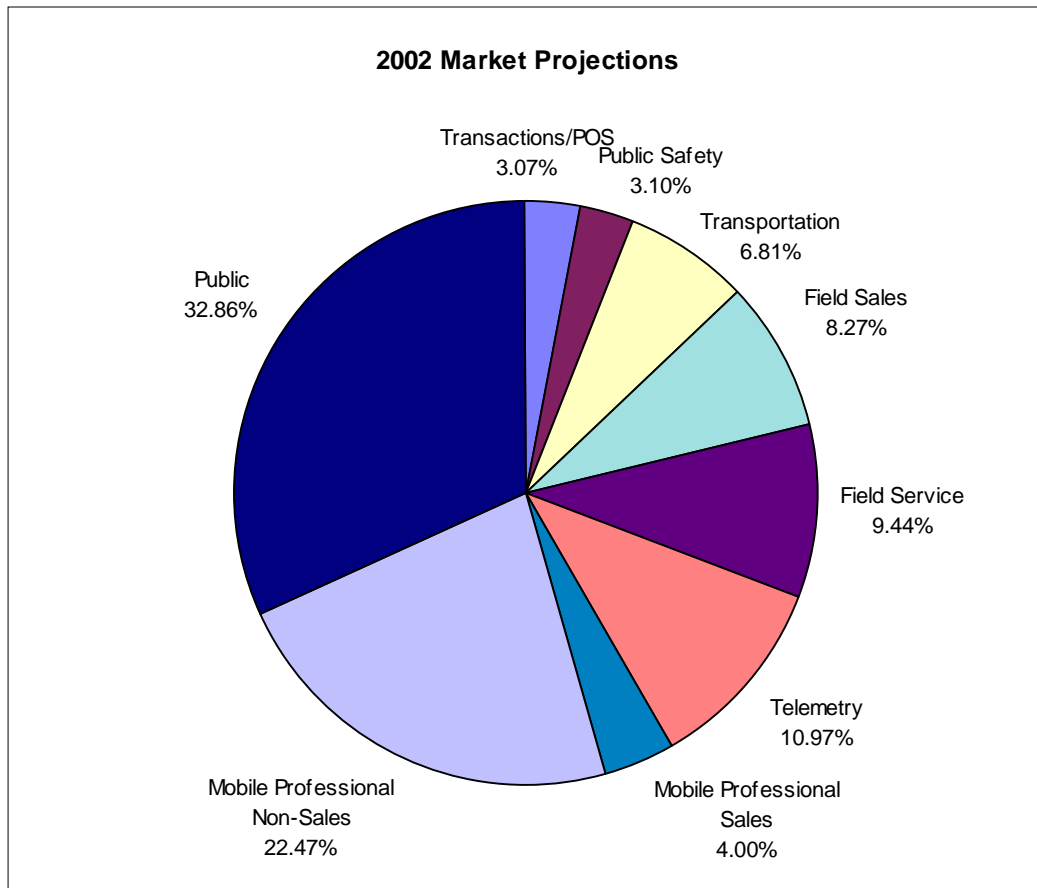
Particularly interesting are “Transportation”, which tries to account for the wireless data users in the transportation field not covered by other categories (from some commercial fleets, to transit and para-transit fleets), and “Public” which accounts for all private users with wireless access not used for job related purposes (the private usage of company provided equipment by a mobile professional is not considered in this category).

To put the figures in context, at the projected number of “Public” wireless data users in 2002 corresponds to 10.44% of the households so equipped for non-job related purposes. This number is very similar to the one used in the *Evaluatory Design* document: 10% of the households were assumed to have wireless data remote access capabilities.

In any case, the “Public” and the Mobile Professional (Sales and Non-Sales) entries correspond to 58.33% of the total number of users. In spite of the different types of traffic these categories generate, there are two underlying, common activities that gives rise to a background traffic that will dominate the non-ITS traffic: e-mail (retrieval and submission of messages), and Internet access.

These two activities are certainly distinct. E-mail is essentially a symmetric, two-way process, while Internet access (in its strict sense, i.e., not including e-mail), is essentially asymmetric, and forward direction intensive.





**Figure 7.3-1 2002 Wireless Data Market Projections (from External and GTE Market Studies)**

The projections above represent a middle ground, which is probably realistic. This represents neither an optimistic or pessimistic point of view. A good measure of that middle ground can be found in the projections related to the “Public” category, determined as will be shown by the traffic it originates.

It has already been mentioned that the projections for 2002 imply that 10.44% of the households are assumed wireless equipped are not for non-job-related purposes. For the year 2000, the last year for which non-GTE Market Research projections were available, that percentage is only 2.43%. This number is much higher than the 0.61% figure from one study. At the same time, the same 10.44% household penetration for 2002 is approximately half of the 20-25% predicted by some (optimistic) “experts”.

### **7.3.2 Characterization of Non-ITS Applications Traffic**

This section provides a brief assessment of the traffic generated by non-ITS applications. For the specific cases of e-mail and Internet access, enough information exists so that guessing is unnecessary. Information on other non-ITS traffic is more difficult to obtain and validate, and will be addressed with the necessary caveats.

#### **7.3.2.1 E-Mail Traffic Characterization (12.7 Million Users)**

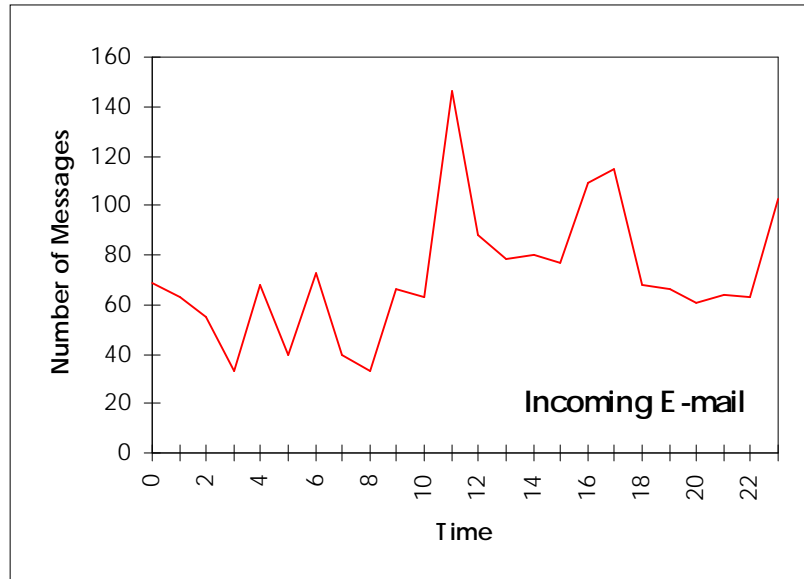
An extensive statistical analysis of e-mail traffic was performed at GTE Laboratories. Incoming and outgoing e-mail was tracked over the period of a few months (to discount the effect of holidays and

vacations), and information was collected regarding the number of incoming/outgoing messages during different periods of the day, for different days of the week, and regarding incoming/outgoing message sizes.

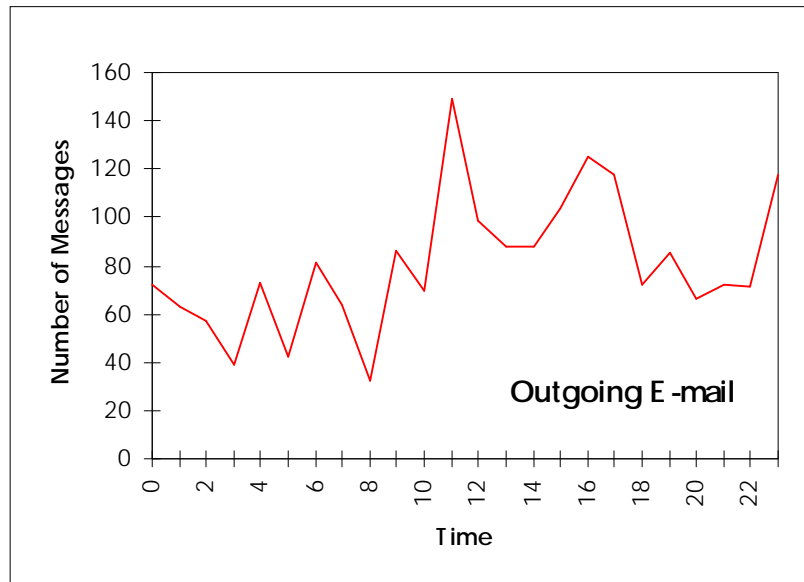
### 7.3.2.1.1 Time-of-Day Characterization

The observed fluctuation of e-mail traffic during the day looks as expected, with two peak periods, one in the morning from 11am to 12 noon, and another, albeit smaller, in the afternoon from 4 to 6 pm. A third, even smaller peak occurs in the period 11pm to midnight as a result of delayed delivery of e-mail.

In terms of impact, it is the afternoon peak period that is of interest, since it coincides with the afternoon rush period. The morning peak coincides with the mid-day lull, and thus does not constitute a critical traffic source. E-mail characteristics over time are shown in Figures 7.3-2 and 7.3-3.



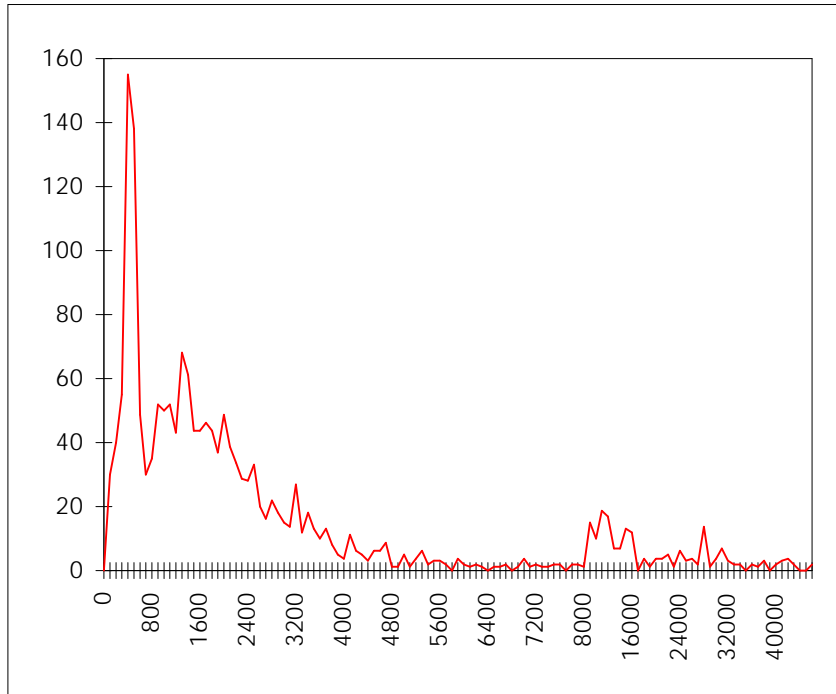
**Figure 7.3-2 Time-of-Day E-mail Pattern -- Incoming E-mail**



**Figure 7.3-3 Time-of-Day E-mail Pattern -- Outgoing E-mail**

### 7.3.2.1.2 Message Size Characterization

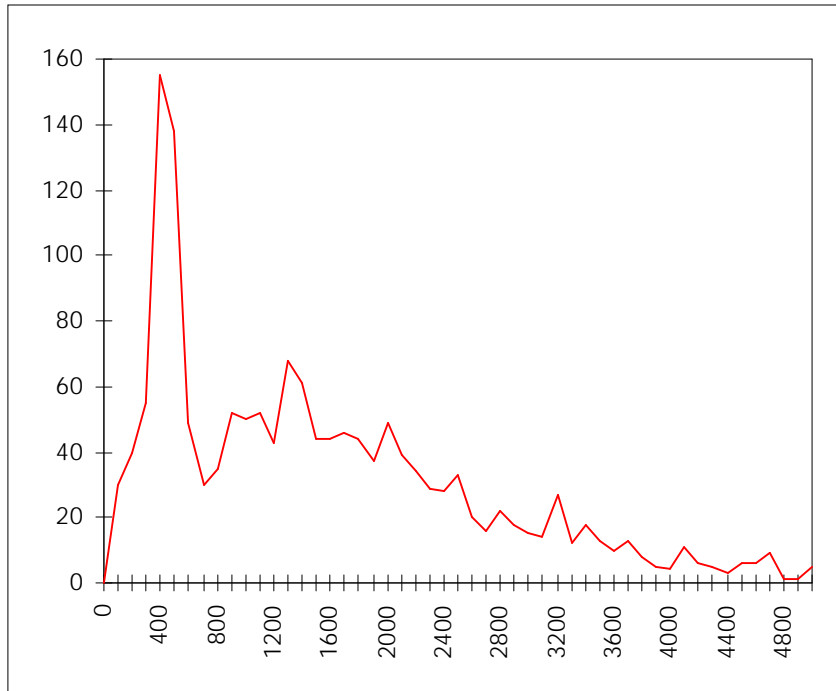
The first assessment is a look at the observed distribution of message sizes (see Figure 7.3-4 and 7.3-5), which includes both incoming and outgoing messages (no difference was observed). Please note that this represents traffic arriving at/departing from a fixed site, that is, the distribution below does not exactly correspond to a mobile situation.



**Figure 7.3-4 Histogram of Message Size up to 100 kbytes (Not to Scale)**

Three underlying distributions can be identified: 1) Small Messages (<500 bytes); 2) Medium Messages (<5 kbytes); 3) Messages with small attachments (<50 kbytes).

It is our opinion that the third type of messages will seldom occur in a mobile environment. For instance, EUDORA lets you not download messages above a given size, which is set by default to 40 kbytes. Therefore, those long messages will not be considered for the purpose of projecting a “mobile” distribution.



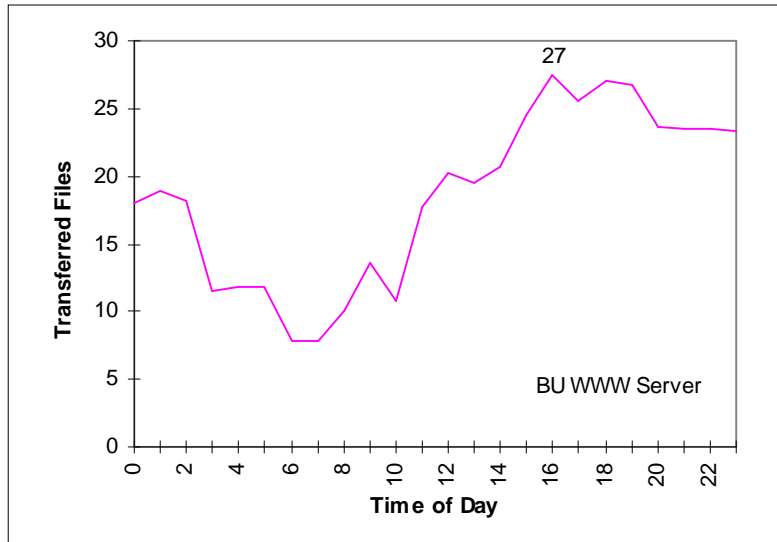
**Figure 7.3-5 Histogram of Wireless E-mail Message Sizes (up to 5 kbytes)**

The above distribution will be used in Chapter 8 to generate e-mail for the purpose of assessing the overall system performance accounting for non-ITS usage of the shared network.

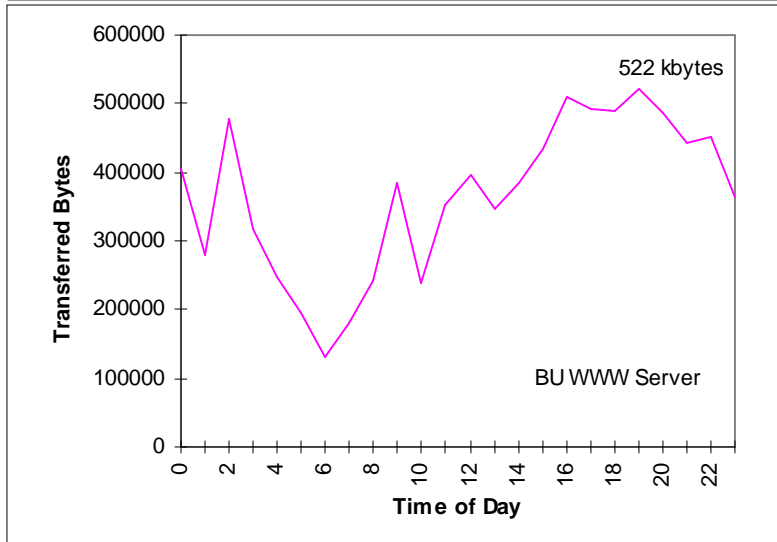
### **7.3.2.2 Internet Access Traffic Characterization (12.7 Million Users)**

An increasingly important fraction of Internet traffic is associated with the World Wide Web (WWW). Given that its importance is bound only to increase, WWW traffic will be used here as a good approximation of overall Internet traffic. This applies particularly to mobile users – although file transfers (FTP) as well as remote login (Telnet) will still occur, most of the file transfers will occur in the process of using (and in fact be subsumed by) Web browsers. For the purpose of identifying the traffic patterns, the hits on two WWW servers at Boston University (BU), and MIT will serve as an example. The charts in Figures 7.3-6 through 7.3-9 were obtained by processing publicly available server statistics information.

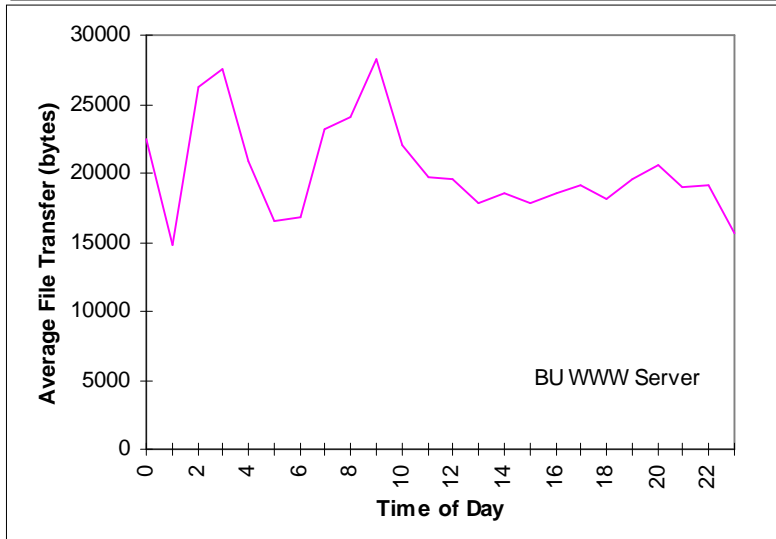
A single peak period has been identified beginning at 4 pm (sometimes extending up to 8 pm) both for file transfers (Web page hits) and transferred information (bytes transferred). The average size of the file transfers per hit does not vary much during the day, which is plausible since when one hits a new URL (even without downloading graphics) one never knows what to expect in terms of a Web site’s information content (measured in terms of bytes, not in the information theoretic sense...).



Average of 444 files a day

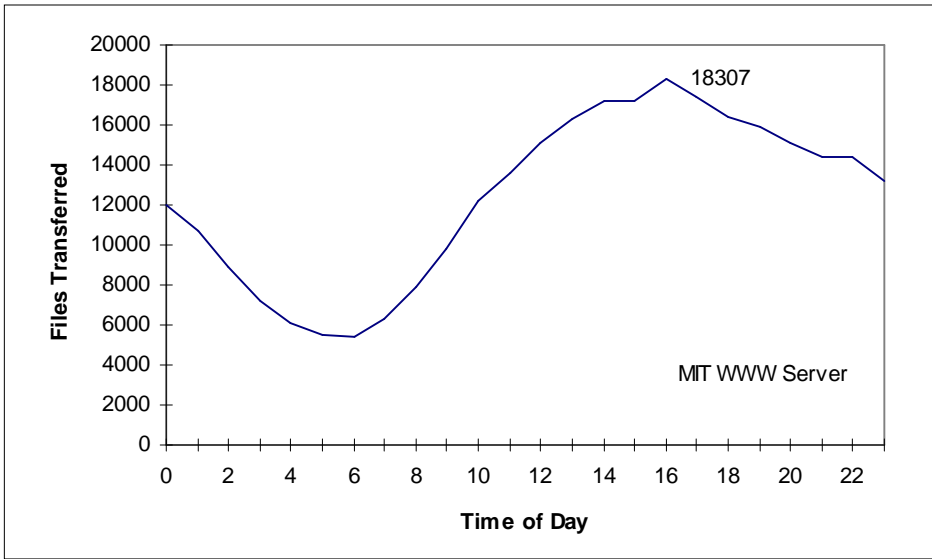


Average of 8.8 Mbytes a day

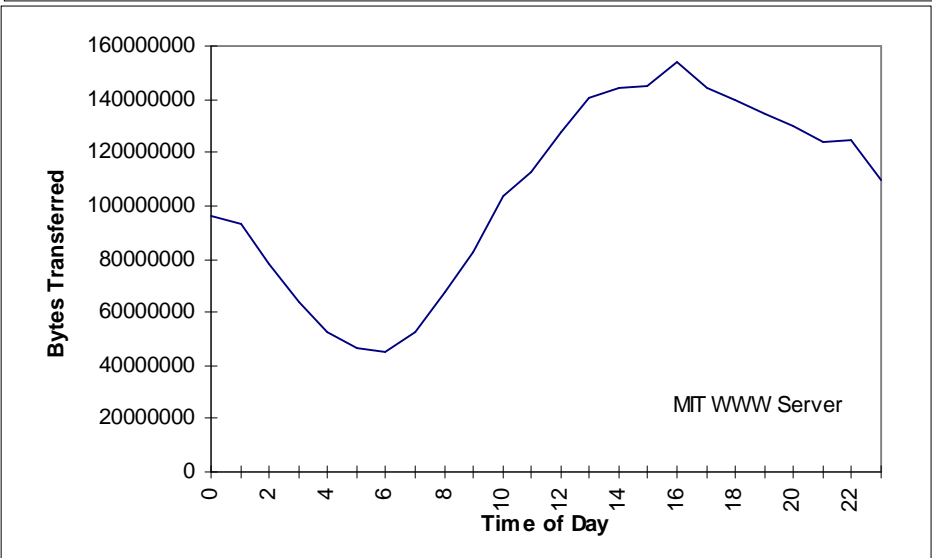


All Day Average: 19760 bytes

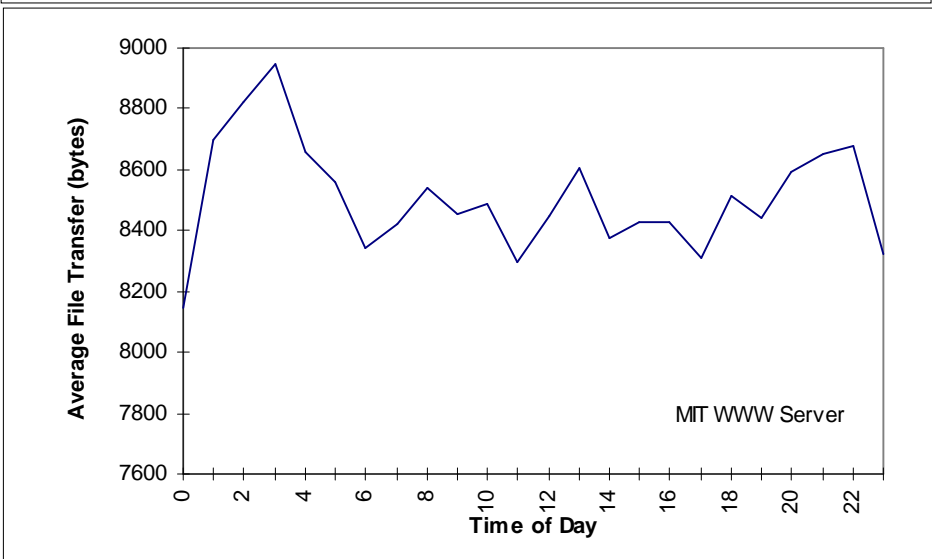
Figure 7.3-6 Daily Statistics for the Boston University WWW Server



Average of 296,217 Files a day



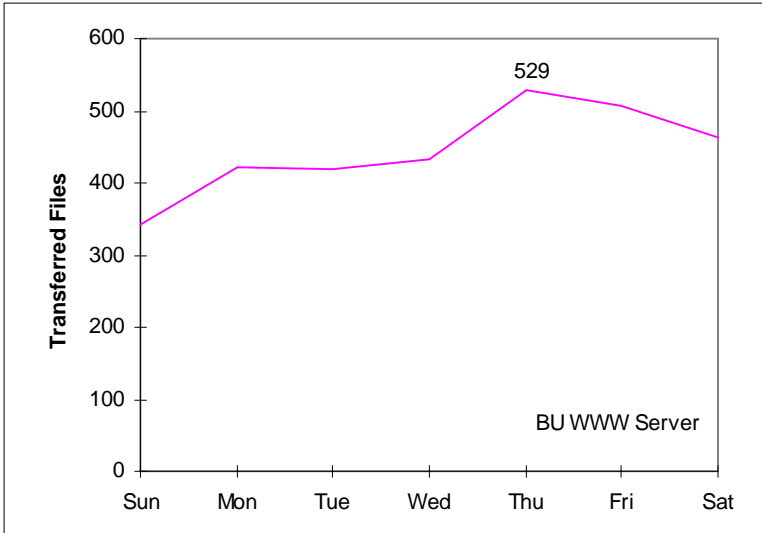
Average of 2,515 M bytes a day



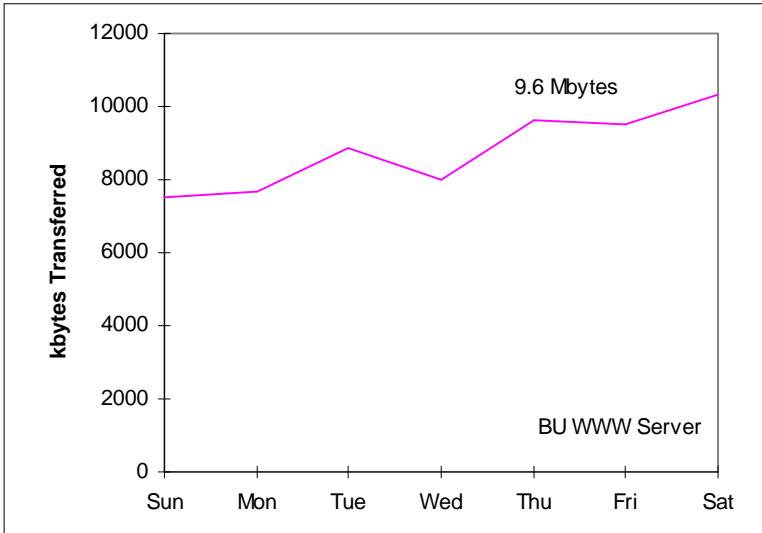
All day Average: 8490 bytes

Figure 7.3-7 Daily Statistics for the MIT WWW Server

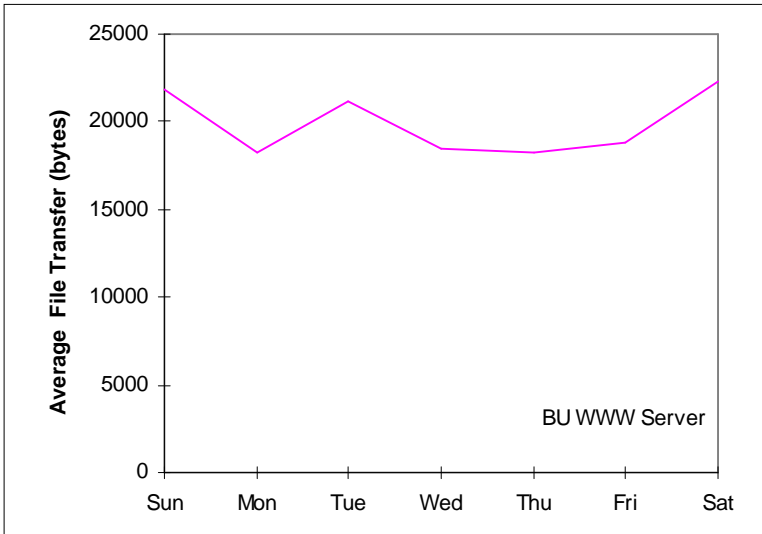
It is now necessary to verify that taking weekends into account here does not skew the traffic characteristics, and especially the average file transfer size per hit.



Average File Transfers: 445

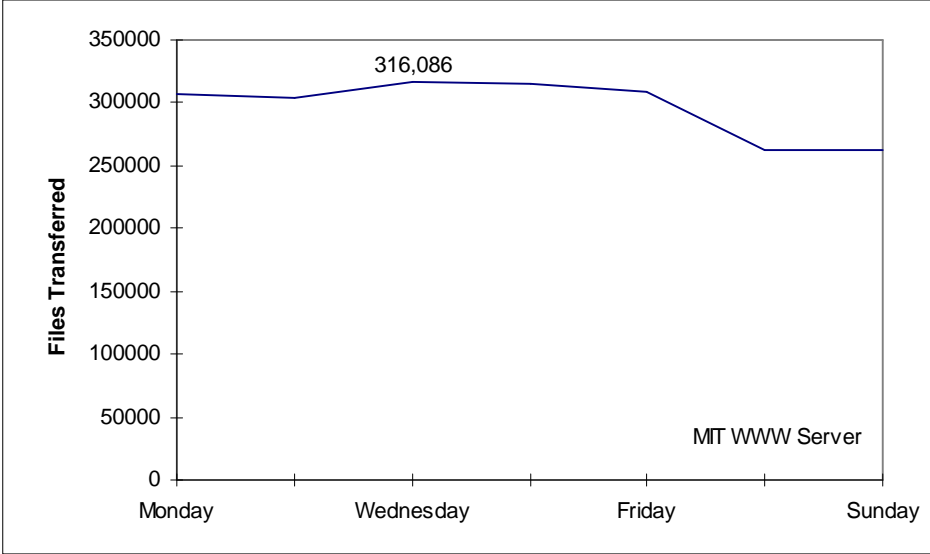


Average Information Transfer: 8.8 Mbytes

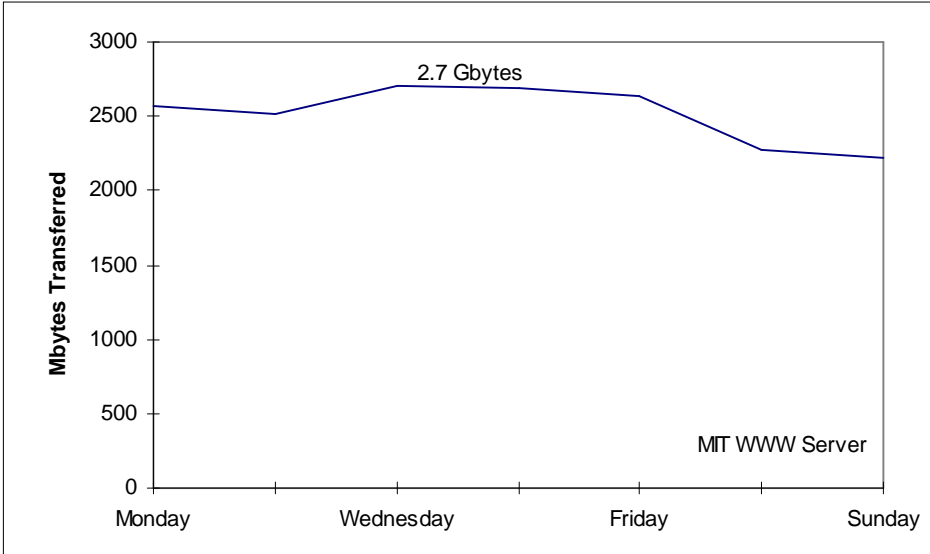


Average File Transfer per Hit: 19,842 bytes

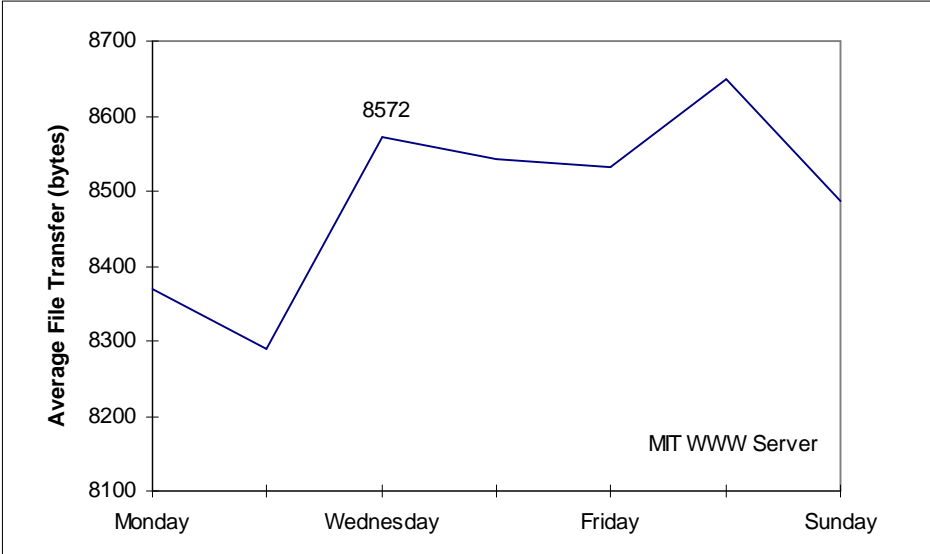
**Figure 7.3-8 Weekly Statistics from the Boston University WWW Server**



Average File Transfers: 296,217



Average Transfer: 2.5 Gbytes



Average Transfer : 8492 bytes

Figure 7.3-9 Weekly Statistics from the MIT WWW Server



Weighting the information above by the utilization of the servers (the MIT server is much more popular than the BU server), we conclude that the WWW peak usage occurs during the period 4 to 5 pm, and that the average file transfer per Web page hit is around 8572 bytes for the peak week day (Wednesday).

That average file transfer per hit will be used in Chapter 8 to generate Internet traffic as one of the components of the non-ITS traffic for the purpose of assessing the overall system performance when accounting for non-ITS usage of the shared network.

### **7.3.2.3 Other Non-ITS Applications**

As stated before, the characterization of the wireless traffic resulting from most of the non-ITS applications is a very delicate task, given that only a few wireless applications exist today. Also, it is impossible to guess what services will be targeted by future applications.

This characterization will therefore be restricted to confirm that all other non-ITS applications contribute little to the non-ITS traffic relative to the E-mail and WWW Access “killer” applications. This is due not only because of their intrinsically sporadic and short burst nature, but because of the associated number of users (refer to Section 7.3.1).

#### **7.3.2.3.1 POS/Transaction Authorization (0.7 Million Users)**

Point-of-Sale activity consists of two distinct types of operations: Transaction Authorization, and (Daily) Settlement. Given that the latter occurs by definition after hours, it will not concern us. As for the Transaction Authorization traffic, it is typically as follows:

- From POS (Reverse Direction): 150-200 bytes
- To POS (Forward Direction): 60 bytes

Today’s national average is of 12 transactions a day per POS, with 15-20 transactions a day in the retail market and a dozen or so in the fast food business, 50-200 a day for gas stations, and 4-6 a day for taxis (variable on a city by city basis). The penetration in the retail and in the gas station markets is expected to be relatively small (mostly wired solutions), and so the bulk of the traffic will come from low traffic users (e.g., food delivery, door-to-door sales, landscaping, pool care, snow removal), and furthermore should have a mostly uniform distribution during the work-day (no peak-periods are to be expected in absence of major influence from retail and fast food).

#### **7.3.2.3.2 Telemetry and Security (2.4 Million Users)**

Within the wealth of activities included herein, without doubt utility (gas, water and power) monitoring dominates, with vending machine remote inventory control and loss management a distant second. In both cases, there is mainly one-way traffic from the meter/vending machine to monitoring/control center (Reverse direction).

Currently, the California Public Utilities Commission (PUC), among others, recommends a 30 minute billing cycle for gas and power. A monthly traffic of 50 kbytes per unit is expected corresponding to 40 bytes per meter every 30 minutes. Only 10% of the meters are considered viable for wireless connection, and substantially less will be thus linked in the near future. As an example, less than 100,000 meters are expected to turn wireless by 2002 in the whole Central and Northern California regions (around 15 million inhabitants). This periodic load will therefore be negligible compared to E-mail and Internet Access.

It is also very clear that vending machine originated traffic, due to its mostly “exception reporting” nature (warning message when “stock” below a given threshold) is negligible. The optional daily reporting will occur after hours and is of no concern.

Security related activity, is even more of an “exception reporting” in nature, especially regarding alarms, and is expected to have no impact. Keycard access reporting is usually restricted to after-hour periods, and so has no impact either.

#### 7.3.2.3.3 Field Service/Sales and Home Health Care (4.7 Million Users)

In this broad category, there are mostly sporadic interactions – usually uniformly distributed during the work day. Catalog/Information access may lead to (infrequent) long transactions, but its overall impact is expected to be small.

Successful applications are expected to avoid transmission of baseline information, reducing traffic to something close to exception reporting. For field sales for instance, availability of an item is the only information that should be transmitted, not the item (from a small part to a house) characteristics themselves. Reporting and order placing are expected to generate even less traffic.

Job dispatch is at the boundary with ITS, and is again expected to limit itself to deviation from plan.

#### 7.3.2.3.4 Public Safety (0.7 Million Users)

Public safety activity is generally an exception reporting nature (e.g., incident reporting), and heavier during the night. The associated traffic will have limited impact during the day, even during peak period. The traffic at night, when the (roadway and communications) network load is substantially smaller, is obviously of no concern.

NCIC inquiry, state and local data base access, shift reporting are all expected to be succinct in the good tradition of intensive code usage.

### 7.4 Protocol and Inter-networking Issues

This section, necessarily short, should not distract the reader from the criticality of the issues under analysis. Inter-networking through multi-layered protocols is the condition *sine qua non* for inter-operating, complex, but adaptable, even self-regulating, networks.

An important first conclusion when analyzing the communications layer of the ITS Architecture, is that it is heterogeneous and highly distributed. Given its impact on the overall system flexibility, there is a need to examine the coexistence of different communication infrastructures. Also within a given type of communication infrastructure, co-existence of competing technologies promoted by dual- and multi-mode terminals needs to be examined. Thus, given the multiplicity of communication systems contending for the ITS market, systems inter-operability issues will be discussed in general in this section, and will be mentioned again on a case by case basis in Section 7.5.

The multi-layer structure of the OSI model is a well established framework for achieving inter-networking. It is not, however, a panacea. One needs to realize that if more than one protocol is at play, a penalty has to be paid: an inter-networking function (not to be confused with the Inter-Working Function (IWF) inherent in all communication systems and discussed in the *Physical Architecture* document) needs to be implemented, usually in the form of a gateway.

Moreover, the multiplicity of protocols, adding to that of the underlying systems themselves, implies that application developers either limit themselves to one or a few system+protocol configurations, or they have to multiply correspondingly their investment to accommodate as many configurations as deemed

necessary for a target market share. (This becomes clearer by analogy with the multiplicity of drivers in today's PC's, the only way an application can deal with different terminal+protocol configurations.)

In an ideal world, only one protocol would exist, and inter-networking would be a given. The flexibility of such a scenario would however be very restricted, since no pull would exist to improve the accepted solution. The message therefore seems to be that **a few well established protocols**, with open interfaces, i.e., open protocols, are needed in order to enable a healthy competition, while keeping inter-networking costs within reason.

The issue of protocol openness versus proprietary solutions is therefore a critical one. If a protocol is not open, it certainly provides protection to its developers from external competition. This is however a short sighted perception: by locking themselves out of the market, the protocol developers miss all the incentives to improve, do not keep the competitive edge technically either, and will soon be put out of business by smarter, more open(-minded) competitors. (The IBM versus Macintosh analogy is telling.)

As for the price, competition certainly benefits the consumer by enabling multi-vendor procurement (an aspect that will certainly speak to the heart of every implementor), but at the same time it also benefits the manufacturer (of software as of hardware): the market grows as the product prices are reduced. One could talk of a bootstrap mechanism. If this process is not ignited, small chances will remain for the manufacturer to recuperate the investment.

Another aspect where open protocols, as well as open architectures, clearly have the advantage is in the application/system development speed and cost. Not having to re-invent the wheel leaves more time for what is really important: to develop a killer application, and then keep improving it. Moreover, by "subscribing" to an open protocol the application developers automatically gain access to a segment of the market. Inversely, by facilitating application development, open protocols create a critical mass of applications that makes choosing the protocol more attractive, i.e., make the protocol more competitive.

The importance of the issues just glossed over, justifies the consideration in the technology assessment of Section 7.5 of inter-networking characteristics in terms of supported protocols and their openness or lack thereof, as well as application development suitability. In the side by side system comparison tables of Section 7.6 those entries are considered essential.

## **7.5 Technology Assessment**

This section reviews both the wireless and the wireline components of the communication infrastructure, analyzing, mostly briefly, the available systems and technologies, while maintaining a National ITS Architecture perspective. Through the comparative evaluation of the alternative candidate communication infrastructures/technologies/implementations, it is expected that the communication analyses will provide a means for the implementors to choose, based upon the MOE's described in Section 3 of the *Evaluation Plan* document, the most suitable set that meets the requirements of (a specific set of) the ITS user services. Furthermore, by incorporating the evolutionary nature of technology into the evaluation methodology, it is expected that the proposed implementation be capable of progressively meeting the steadily increasing ITS demands expected for the next 20 years.

### **7.5.1 Wireless Communications**

One important aspect of the technology evaluation in this section is addressing the evolution of the wireless technologies, with expanding capacities and increased sophistication. Another is examining the coexistence of infrastructures such as today's mostly analog cellular with upcoming digital cellular and with PCS, all with their tremendous potential to support ITS needs. Additionally, within a given communication infrastructure, competing technologies may have to coexist, like CDMA and TDMA.

Thus, given the expected multiplicity of communication systems contending for the ITS market, issues of systems inter-operability will be emphasized, given its impact on the overall system flexibility and the appeal to the end-user, as well as the wider market thus made available to all Information Service Providers (private and/or public).

Within the wide-area communication systems under consideration, different levels of detail will be considered, related to the amenability to simulation of the different systems. As an example, extensive work has been done to acquire simulation capabilities for Cellular Digital Packet Data (CDPD) as detailed later in Section 8, as well as for other cellular systems, such as TDMA- or CDMA-based. The same can not be said, however, of other communication systems that are either proprietary in nature or just not open (e.g., RAM, ARDIS), still far from standardization, or entirely new (e.g., Omnipoint, Geotek), or uncertain (e.g., Nextel). Whenever possible, analytical results will be made available for those systems still in the standardization phase, and performance information will be collected for the proprietary systems and will be reported with the necessary caveats later in this section.

Our wide-area analysis begins with a look into systems that if not exactly suited for mobile applications, provide communication over a wide-area, namely Wireless MAN's. Their use applies at least to wireless access to kiosks (RTS) and to remote access to ITS information (PIAS). Other low-mobility applications are also possible. The analysis here is only a review of technical information made available by the vendors.

The land-mobile arena is the one where more choice exists, given the exploding mobility market. Cellular is looked at first. CDPD is the first system to be analyzed. The analysis in this section is only of a very general nature. The performance information obtained in the course of the National ITS Architecture Study, and is reported in detail in Section 8.

CDMA data systems are evolving in the standards bodies, and thus elicit preliminary quantitative analyses, with the little that is known at this moment. Similarly, Europe has a packet radio system in the works for GSM. These systems will also be briefly analyzed. To the extent that information is available, PCS will also be addressed, although the data protocols are not expected to be specific — available data protocols will most likely be used.

Private Mobile Data Networks, as well as SMR systems will also be analyzed with a level of detail permitted by their proprietary nature. ARDIS, RAM, and a new entry from Geotek, as well as Nextel's digital system, will be assessed for their potential to provide mobile solutions.

Finally, Two-Way Paging, the first service made available over the newly licensed Narrowband-PCS, is analyzed to assess the potential of its somewhat limited scope.

To meet the requirements imposed by the 29 user services defined in the National ITS Architecture Plan, and to provide services to a wide range of areas including rural settings, a hybrid of terrestrial and satellite services may be required in some situations. The projected satellite services and their capabilities, as well as the integration of satellite services with other terrestrial infrastructures, such as cellular, in support of the ITS system architecture, will therefore be analyzed with the detail warranted by the scarce information available.

Meteor scatter systems will be analyzed in some detail given that the systems are being used among other purposes for long haul fleet management. It is interesting to realize that this system relies on the statistical availability of meteor trails to provide reliable service over large areas.

As for broadcast systems, attention will be given especially to high speed FM subcarrier systems. New systems like Digital Audio Broadcasting (DAB) and those based on the use of the TV stations' vertical blanking periods or the entire SAP channel will be alluded to. The level of detail of the analysis will be determined by the predicted role of the technology in supporting ITS services.

Finally, a beacon-based wide-area “solution” will be briefly investigated, given that a preliminary analysis clearly points to the fact that such an approach does not insure seamless coverage of a wide-area, is inappropriate for time sensitive services in a wide area setting, and has high cost and risk associated with it.

Also briefly discussed are short-range communication systems, focusing mainly on dedicated short range communication (DSRC), by comparatively describing the salient systems. Vehicle-to-vehicle communication systems are still in flux, many not even in the prototype phase, and thus are only briefly analyzed here. More detailed information will become available from the AHS Consortium.

### ***7.5.1.1 Wide-Area versus Short-Range***

The 29 ITS services defined by the Government fall into two distinct classes in terms of the range for the distribution and collection of ITS information, with correspondingly different associated coverage areas: wide-area and short-range. Wide-area services and applications disseminate information over a large area. Very often the information can be directed to a specific user. Natural candidates for this type of delivery are today’s cellular systems, tomorrow’s PCS, satellite, and even broadcast systems. Less natural would be the provision of wide area information via widely dispersed beacon systems, the most obvious problem being that seamless coverage is not possible (see Appendix G).

Short range services and applications, on the other hand, concern information transfer of localized interest. Two types of short services need to be considered: 1.) dedicated short range communications (DSRC), corresponding to a fixed end system (even if portable) to mobile system short range communications (e.g., toll collection, roadside vehicle inspection), and 2.) vehicle-to-vehicle communications (VtoVC) associated with AVSS/AHS. For the former type of application, beacon-like systems are appropriate. For the latter, most likely dedicated radio systems will be used. These are under consideration both in the U.S. and in Europe, but are far from maturity.

Given the dedicated nature of the beacon-like systems and their small coverage area, no need exists for simulating their capacity performance — the reduced number of active users simultaneously within range makes it possible for the specifications to insure they perform with acceptable reliability even in the case of multilane transceivers.

As for VtoVC, which is still mostly in its research phase, a meaningful analysis is not feasible and therefore the Joint Team will primarily report on the evolution of those systems.

#### **7.5.1.1.1 Wireless MAN Systems for Stationary Users**

One possible wide-area wireless data solution consists of systems that are cell-based such as RAM, CDPD, and ARDIS and can serve both mobile and fixed subscribers (described in detail in the following section). Another group of systems uses Wireless MAN systems, which targets exclusively the fixed wireless subscribers, due to the nature of the technology and of the network.

The fixed subscriber wireless data technology uses microcells (the footprint of a microcell is less than a 0.5 mile in diameter) which is less complex, but also less flexible, than cellular implementations. As a result, this service is restricted to fixed subscribers, with limitations on mobility and on coverage area to the supporting microcell (no hand-offs possible). Such systems generally utilize packet data communication, some even offer TCP/IP connectivity.

The network implementation is of a meshed nature, usually with only a few wired base stations (implying a multi-hop system). As a result, the delay varies widely, depending on whether the user is serviced by a wired or tetherless base station (that is, the system cannot guarantee an arrival time).

Intended services include on-line applications such as Internet access, mobile office applications, and even telemetry. The candidate ITS services, subscribers, and messages that can be supported using these Wireless MAN solutions include:

- Fixed ITS subscribers (e.g., home, office and kiosk).
- Low-mobility applications (i.e., pedestrian speeds) that are not time critical and do not require real-time response.

The two systems that are reviewed here are offered by Metricom Inc. and Tetherless Access Ltd. (TAL). Both systems utilize spread spectrum communication for their wide area wireless interface. Metricom uses frequency hopping and operates in the 902 to 928 MHz band. TAL uses direct sequence spread spectrum technology licensed from Cylink, in the 900 MHz, or 2.4 GHz band.

The occupied bands fall in the unlicensed ISM bands for spread spectrum (SS) systems (Part 15.247 of the FCC rule). Although this makes system deployment much easier and cheaper, it also raises problems of subsidiarity. In fact, unlicensed spread spectrum ISM devices are at the bottom of the priority list: they must accept all interference from other devices operating in that band, but cannot interfere with any other system. Presently, the FCC is considering lowering even further SS ISM's priority in favor of AVL systems.

#### *7.5.1.1.1.1 Metricom's Ricochet*

The Metricom system uses 162 channels for frequency-hopping spread spectrum (FH-SS) communication. In this system, each channel occupies 160 kHz and is selected using a unique pseudo random sequence.

Each radio in the network (bracket-mounted, shoe-box size, typically installed on utility poles, streetlights, and building roofs), is mesh connected on typically a one-mile grid. Each radio can originate messages, send and receive information, and select alternate routing paths in the event that other radios are busy or out of service (i.e., multi-hop mesh architecture). Transmission time from a Ricochet modem to a poletop, and from poletop to poletop, is typically less than 100 ms. To enhance network performance, wired access points (WAP) are interspersed among the mesh radios, and connected to a high-speed wired backbone. A WAP is deployed for each 100-120 poletops.

The system uses packet data communication (500 bytes/packet). Longer messages are typically broken into smaller packets and transmitted on different channels. However, these long messages are more difficult to be properly received, even by the intended user: sequential packets from the same message may end up following different paths (i.e., undergo different hops) to their common destination.

Metricom has deployed the system in the San Francisco Bay Area (3,500 repeaters covering more than two million residents in 35 cities; see Figure 7.5-1), Corvallis, OR (servicing 45,000 people in the city of Corvallis, Oregon Sate University, and Hewlett Packard's OmniBook division campus), Eugene, OR (50 transceivers servicing the University of Oregon campus), and in Dearborn, MI, where the Wireless Health Information Network services a group of physicians and clinics, providing real-time access to patient-authorized clinical data, as well as care guidelines. Metricom has visible presence in colleges and corporate campuses nation-wide (Stanford, UC Santa Cruz, UC Berkeley, CA; Austin College, TX; University of Miami, FL).

Metricom has already formed a joint venture with the Potomac Electric Power Co. to deploy the system in the Washington, DC, area to provide service to four million potential users. Metricom will deploy its system in the Seattle area during 1996. Next on their list are Boston, MA, and the Redmond-Bellevue, WA area.

Services offered include access to the Internet (through a proprietary gateway, since the system is not TCP/IP based, although the modem implements SLIP and PPP), and to e-mail, on-line services, and corporate LAN's and WAN's. ( According to the UC Berkeley Telecommunication Services, services that are expected to work well are those that involve transfer of "large" amounts of data at once, like "FTP", POP-based e-mail, and Internet access, while "telnet" and "rlogin" are likely to be very frustrating to use because of their interactive, usually small "packets" nature.) Metricom also provides private wireless data networks to the utility, wastewater, gas and oil industries.

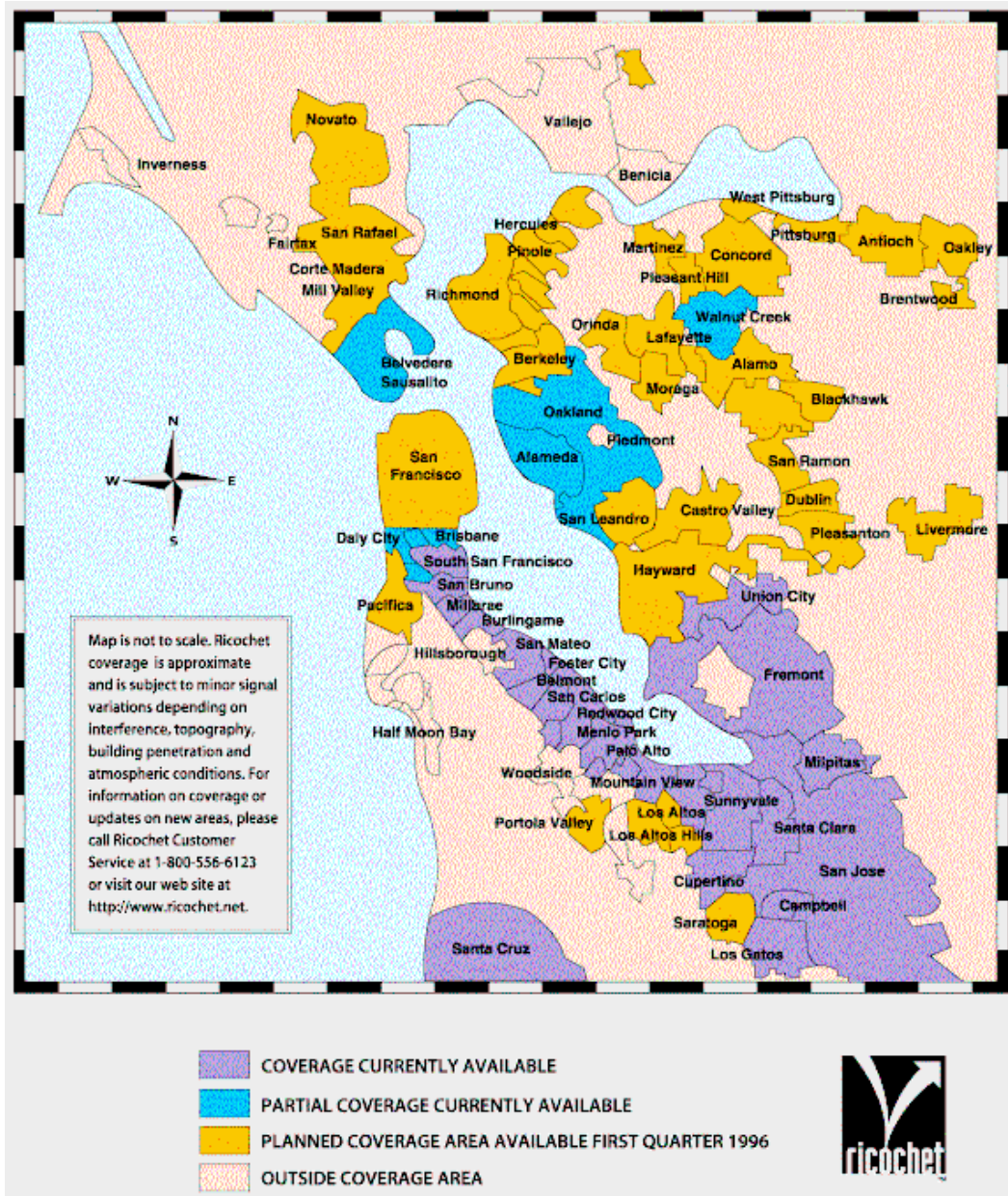
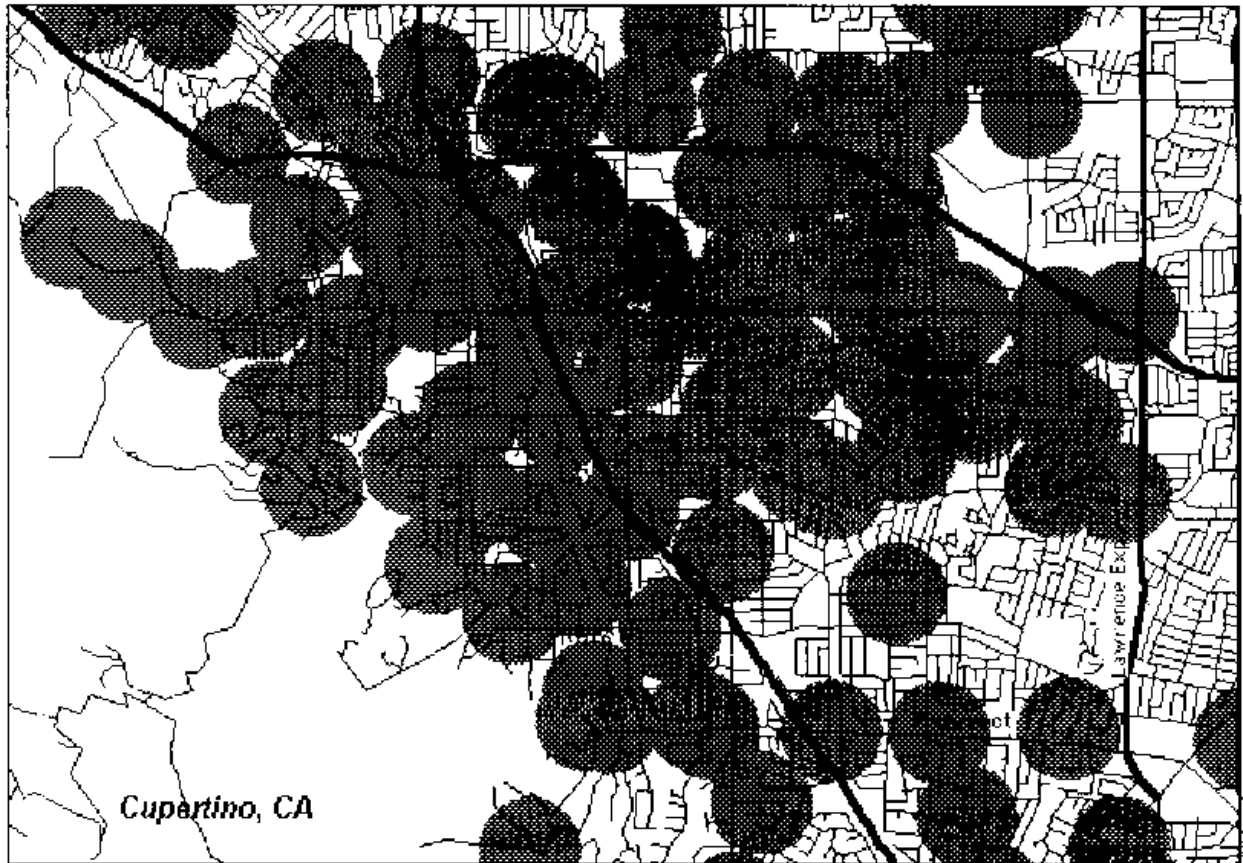


Figure 7.5-1 Metricom's Present and Planned Coverage in the San Francisco Bay Area

One issue affecting the deployment of a system like Metricom's, with so many base stations<sup>3</sup>, even if pole mounted, is the need to obtain the right of way. This problem has to be resolved on a city by city, or county by county basis. (An example of a city-wide deployment of Metricom's system is shown in Figure 7.5-2.) That is one of the reasons why Metricom has entered into agreements with utility companies (PacifiCorp, a Portland, OR-based utility company serving portions of seven Western states, and the above mentioned Potomac Electric Power Co. in Washington, DC) and cities (30 cities in the San Francisco Bay Area, as of 10/18/95). In a representative arrangement, in Cupertino, CA, the network is used to support CityNet, providing education links through the city school system, links to emergency services and government departments, as well as communications between citizens and government officials.



**Figure 7.5-2 Example of a City-wide Deployment of Metricom's Ricochet System**

#### 7.5.1.1.1.2 TAL's SubSpace 2001

TAL's networking architecture is TCP/IP-based, using direct sequence spread spectrum (DS-SS) packet radio to deliver wireless data. The system selected direct sequence for its better performance against multipath, especially for the high data rates of the network (160 kbps). The radios operate either on the 902-928 MHz or 2.4-2.4835 GHz ISM bands, providing more flexibility than Metricom's alternative.

TAL provides peer-to-peer, multipoint networking, and TCP/IP routing over a wireless mesh network where each cell can extend up to 30 km (18.6 miles). The radio technology used by TAL, SubSpace™

<sup>3</sup> Base stations are situated every half-mile on average, or 4 to 5 per square mile, with downtown concentrations of up to 30 radios per square mile



2001, was jointly developed with Cylink Corporation. It is based on Cylink's AirLink MP product, incorporating unique features which are supported by TAL's packet router software.

The SubSpace 2001 system includes a Wireless Router™ for wireless networking, a spread spectrum radio, and TALtalk, the proprietary wireless network operating system software. The SubSpace router is wirelessly connected to the gateway (called POP, provider's point of presence), which provides the subscribers backbone connectivity.

TAL deployed pilot networks in Colorado Springs and Telluride, CO, and in the San Francisco Bay Area. Numerous systems have also been deployed abroad (São Paulo, Brazil; Sidney and Melbourne, Australia; China). Contrary to Metricom's direct involvement in exploiting its networks, in fact acting as a service provider, in the US, TAL follows a partnering model: TAL licenses its technology on a non-exclusive basis to regional Internet Service Providers and local system integrators developing data networking services.

#### *7.5.1.1.1.3 Comparative Analysis*

Table 7.5-1 summarizes the technical specifications of Metricom's, and TAL's systems, and includes some cost information.

**Table 7.5-1 Technical Specifications of the Wireless Data Technologies for Fixed Subscribers**

System Specifications	System Name	
	Metricom	Tetherless Access Ltd. (TAL)
Band	902-928 MHz (ISM band)	902-928 MHz or 2.4-2.4835 GHz (ISM bands)
Raw Data Rate (kbps)	up to 100	160
Sustained System Throughput (kbps)	9.8 to 28.8 half-duplex (depending on hardware, location, and application)	64 half-duplex
Interface	PC, Mac and PDA serial port Proprietary interface	PC's, workstation TCP/IP
Hardware and Software	Proprietary software	Wireless router and proprietary network operating software
Service Cost	\$40 setup \$40 monthly fee, with unlimited Internet access	The service cost will depend on the size of the network, and on the service provider.
Terminal Cost	\$300 for modem	?
Deployment Cost	\$700 bracket-mounted radios  ?	\$1995 per node for SubSpace™ 2001 wireless router (L band). + \$1500 licensing fee (software) + \$150 antenna
Services	Internet Access	LAN access,...
Mobility	Walking (within the coverage area of a microcell); No Hand-off	Fixed (stationary)
Deployment	San Francisco Bay Area, CA; Corvallis, Eugene, OR; Dearborn, MI; Miami, FL; Austin, TX 1996: Washington, DC Future: Redmond-Bellevue, WA; Boston, MA	Pilot networks: Colorado Springs, Telluride, CO; San Francisco Bay Area, CA  Abroad: Brazil, Australia, China
Technical Maturity	The system is commercially available and in operation in limited markets	The system is presently available, for transfer/sale to candidate service providers
Latency	Delays are a function of the location, network load, and application. No guarantee for time critical interactions.	NA
Message size (packet)	500 bytes per packet Long messages are broken into small packets and sent on multiple channels	NA

Note: The data in this table was obtained from material provided by the service providers, and has not been verified, through field measurements and/or simulations, by the ITS Architecture Team

#### 7.5.1.1.2 Land-Mobile Cell-Based Systems

Land-mobile systems, as opposed to satellite-mobile and broadcast systems, are analyzed in this section. The section begins with Cellular Digital Packet Data (CDPD), under its conventional and circuit-switched (CS-CDPD) forms, and looks also into future developments (CDPDng = CDPD next generation). Also considered are other, not fully standardized (as of yet) data systems based upon CDMA, TDMA, hybrid TDMA/CDMA, and GSM/DCS 1800. Private Data networks, ESMR, and two-way paging systems are also examined.

#### *7.5.1.1.2.1 Cellular Digital Packet Data (CDPD)*

Cellular Digital Packet Data (CDPD) was designed to provide packet data services as a digital overlay to the analog cellular (AMPS) network. CDPD was developed by IBM and a broad consortium of cellular carriers (McCaw Cellular, GTE Mobilnet/Contel Cellular, Ameritech Cellular, Bell Atlantic Mobile Systems, NYNEX Mobile Communications, PacTel Cellular, Southwestern Bell Mobile Systems, and US West) that cover 95% of the US, including all major urban areas. The first specification was published in July of 1993, and commercial operation began in 1994.

In mid-1994, 69 cellular carriers and equipment manufacturers, formed the CDPD Forum, whose purpose is to foster the widespread deployment of CDPD service. Today, approximately one hundred companies belong. While the group is not a formal standards organization, it formed technical working groups to study various enhancements to the original CDPD specification, leading to Release 1.1 of January 1995. The CDPD Forum is effectively in charge of the evolution of the CDPD specification.

By leveraging the enormous pool of radio infrastructure and network resources fielded by the cellular industry, and by being the only open system architecture digital packet data system already standardized, and by undergoing rapid deployment across the US, it is poised to be a strong contender for a wide range of ITS applications, at least in the near to medium term (5- to 10-year time frame). Due to the resilience of deployed technologies (e.g., FM broadcast has been around for almost 60 years), CDPD could still play a significant role not only at the 10 year snapshot but also to the 20-year time frame.

A simulation of CDPD capabilities in an ITS context, particularly within the confines of the Urbansville scenario, was the starting point in the architecture evaluation in Phase I. The emphasis has in the meantime shifted to obtaining an assessment of the ability of CDPD to satisfy the projected ITS data loads for different scenarios and time frames, both under normal conditions and in presence of incidents. All these issues will be dealt with in Section 8.

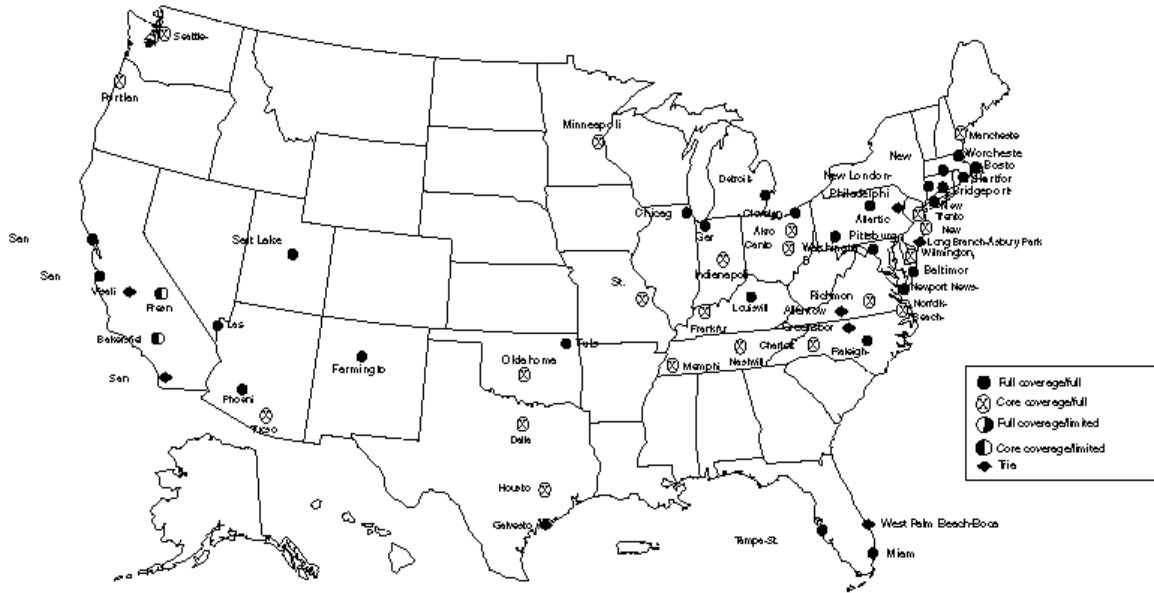
Note that this in-depth analysis of CDPD should not be construed as a selection of CDPD as the basis for ITS service provision. Other technologies will certainly be available, but CDPD will likely be one of the alternatives.

##### **7.5.1.1.2.1.1 CDPD**

CDPD is a digital overlay on analog cellular (AMPS) that makes use of idle voice channels. Its first specification, Release 1.0, dates from 1993 and many commercial systems are already in operation across the U.S. (see Figure 7.5-3) and abroad (Canada, Mexico, Brasil). Release 1.1 has been available since January 1995 and has already been deployed widely by some providers. The following paragraphs briefly describe the CDPD network structure (see Figure 7.5-4), which is very similar to that of the cellular network with which it shares transmission channels.

Each mobile end system (M-ES) communicates with a mobile base station (MDBS), which is expected to be collocated with the cell equipment providing cellular telephone service to facilitate the channel-sharing procedures, as well as the real estate. All the MDBS's in a service area are linked to a mobile data intermediate system (MD-IS) via wireline or possibly microwave links. The MD-IS provides a function analogous to that of the Mobile Switching Center (MSC) in a cellular telephone system. It also provides connection to a network management system. The MD-IS may be linked to other MD-IS's and to various fixed end-systems (F-ES's) outside of the CDPD network.

# CDPD COVERAGE FOURTH QUARTER 1995



\*Coverage shown is from CDPD Forum member carriers

Figure 7.5-3 CDPD Deployment as of the Fourth Quarter of 1995

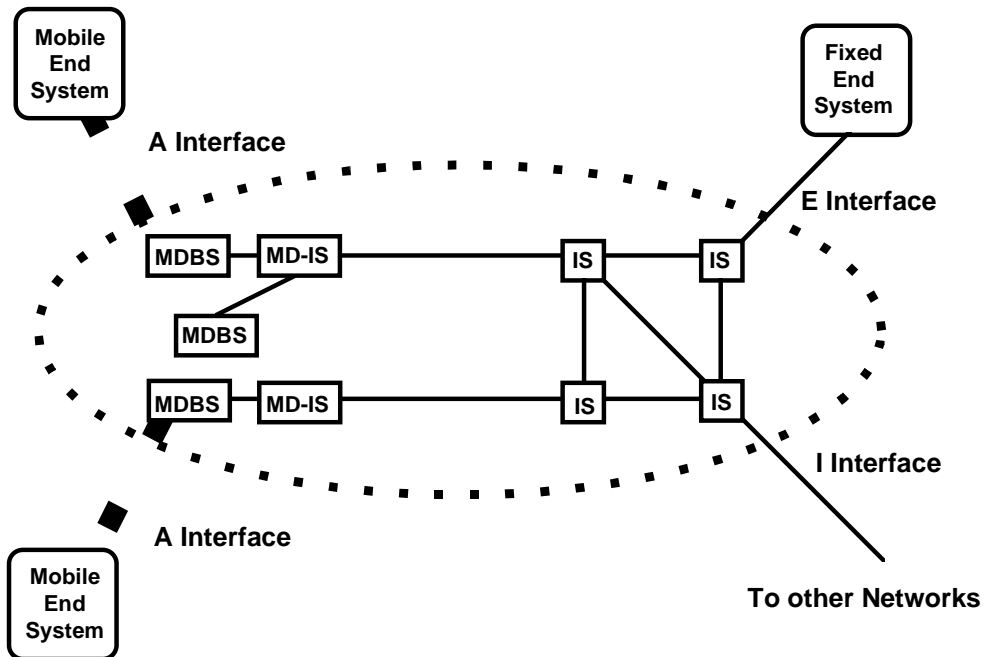


Figure 7.5-4 CDPD Network Architecture

(From *Wireless Information Networks*, K. Pahlavan, A. Levesque, John Wiley & Sons, Inc., 1995. Note: the A interface is referred to in this document as the u1t interface).

Service endpoints can be local to the MD-IS (E interface) or remote, connected through external networks (I interface). An MD-IS can be connected to any external network supporting standard routing and data exchange protocols (it inherently supports IP and ISO CLNP routing and can be connected through appropriate gateways to other types of networks). It can also provide connections to standard modems in the PSTN (using SLIP or PPP's) by way of appropriate modem interworking functions (modem banks).

Connections between MD-IS allow routing of data to and from M-ES's that are roaming (i.e., operating in areas outside their home service areas) by allowing the MD-IS's to exchange information required for mobile terminal authentication, service authorization, and billing. (Roaming has been extensively and successfully tested by the many CDPD providers.<sup>4</sup>)

CDPD employs the same 30 kHz channels used by AMPS. Each CDPD channel will support channel transmission rates of 19.2 kbps. However, packet collisions (and radio channel impairments) will limit the actual information throughput to lower values, and will introduce additional time delay due to the Forward Error Correction (FEC) and re-transmission protocols. In Section 8 we will see that the Reverse Link capacity is approximately 11 kbps, corresponding to 8 kbps of user data. As for the Forward Link, without contention, the capacity is very close to the raw data rate, corresponding to approximately 14 kbps of user data.

The performance of CDPD equipped cellular infrastructure for a mix of voice and data users hinges on the combined performance of the Physical layer and the Medium Access Control (MAC) layer on top of it. The task of the Physical layer design is to control the interference induced by co-channel voice users in other cells through the use of power control and forward error correction (FEC), in this case using a Reed-Solomon (RS) (63,47) code. The MAC protocol, on the other hand, resolves contention on the common reverse channel due to the competition with the other data users within the same cell.

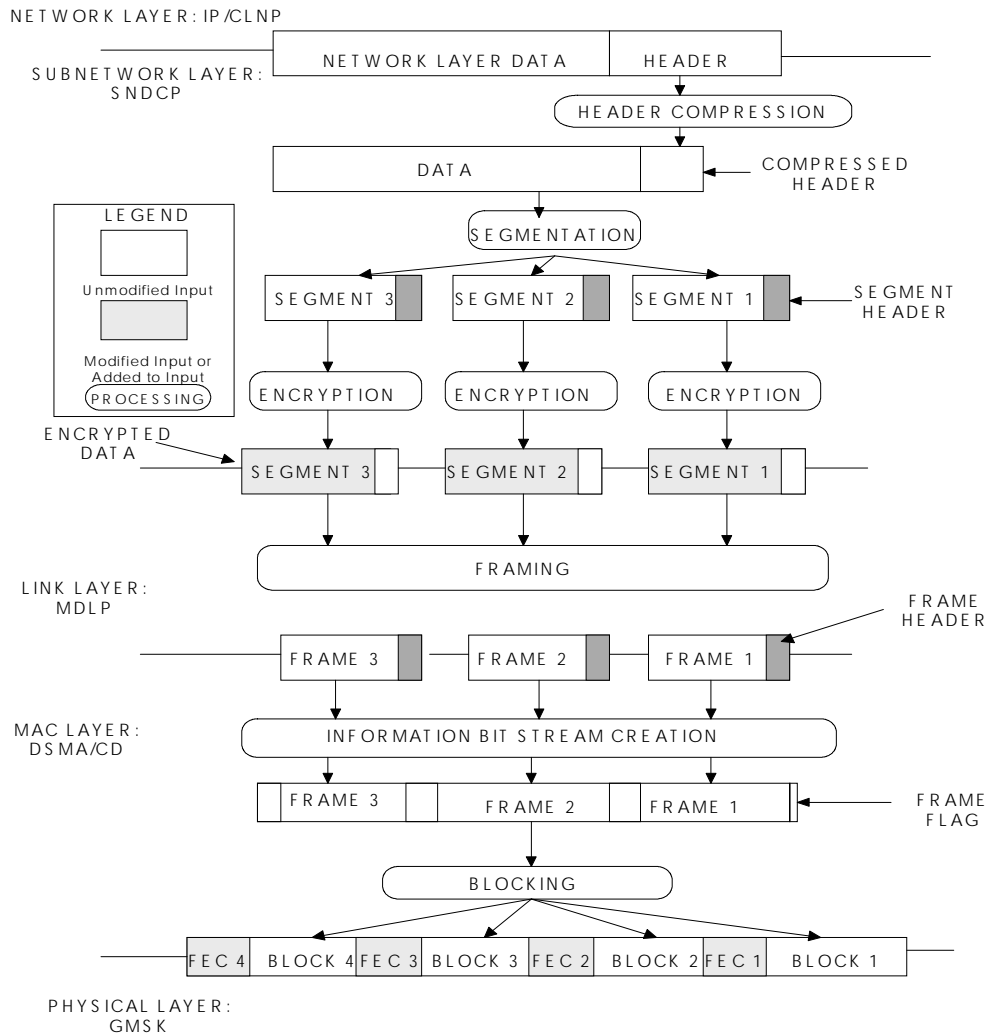
The selection of a channel for CDPD service is accomplished by the radio resource management entity in the MDBS. Through the network management system, the MDBS is informed of the channels in its cell or sector that are available as potential CDPD channels (channels not in use for analog voice service). The MDBS can determine whether a given channel is in use either through a communication link to the AMPS system, or, if that link is not available, it can use a forward power monitor (a "sniffer") to detect channel usage on the AMPS system.

Multiple access to the CDPD channel occurs in two very distinct forms, depending on the direction of the communication. On the forward channel, from the MDBS to the M-ES, there is no contention, since the MDBS broadcasts information to all users, which will then filter out the portion directed to each of them. (It must be noted here that Release 1.1 of the CDPD Specification now enables actual Broadcasting -- sending messages to all users, and Multicasting -- sending messages to a group of users.) It is important to realize that even if the information is openly broadcast to everyone, only the intended user can make sense of the message due to the encryption performed (see Figure 7.5-5).

On the reverse channel (from the M-ES to the MDBS), access control is more complex, since several users share the same channel. CDPD uses the multiple-access technique called Digital-Sense Multiple Access/Collision Detection (DSMA/CD), whereby the MDBS announces the channel status (idle or busy), and more importantly immediately broadcasts the occurrence of collision, avoiding a lengthy recovery process. The conflicting users promptly enter into exponential back-off, thereby reducing the associated dead-times.

---

<sup>4</sup> Unlike cellular voice, there are no "roaming fees" in CDPD.



**Figure 7.5-5 CDPD Protocol Stack (CDPD System Specification, Release 1.0)**

CDPD is a TCP/IP-based packet data system, therefore making immediately available all TCP/IP applications in a mobile environment (e.g., FTP, Telnet, Internet access) through the use either of the TCP/IP stack included in certain CDPD modems, or of a TCP/IP stack available in the laptop/computer.

Recently, Release 1.1 has become operational in many markets. The advantages of the new release are obvious for high traffic markets, since the data compression mechanism in Figure 7.5-6, V.34, provides a gain that can be as high as 4, depending on the data being sent. The users will see, as a result, a correspondingly increased throughput.

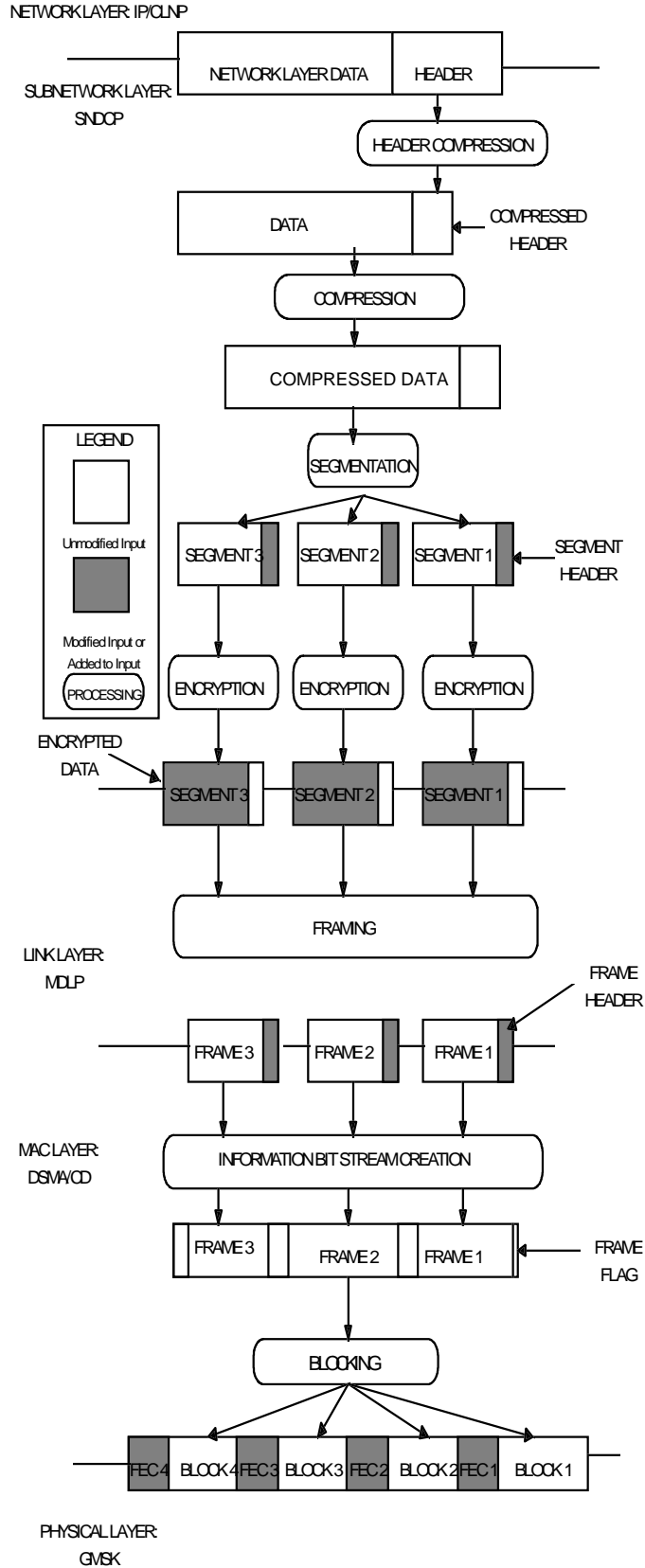


Figure 7.5-6 CDPD Protocol Stack (CDPD System Specification, Release 1.1)

#### 7.5.1.1.2.1.2 Circuit-Switched CDPD

An extension to CDPD providing circuit-switched (dialup) access to CDPD service has been recently proposed (*Circuit-Switched Cellular Digital Packet Data*, Release 1.3, April 14, 1995) as an alternative to the standard CDPD radio interface. This new form of access uses existing technology to extend the geographic regions and the range of applications that can use the CDPD network. The general attributes of the new service include:

- Customer-selected access to the CDPD network via CDPD radio, AMPS cellular, or land-line PSTN
- Support for Multicast and point-to-point IP services
- Support for all CDPD security features (authentication, and encryption)
- Seamless roaming between conventional and Circuit-Switched CDPD
- Extension of CDPD service to regions that lack CDPD radio coverage
- Support for economy measures that allow a user to divert non-interactive, bandwidth-intensive applications, such as facsimile, and large file transfers to a circuit
- The ability for either the MD-IS or the MES to drop the dialup circuit when traffic temporarily ceases and to re-dial it when traffic resumes – this feature will save the subscribers considerable amounts of money in air-time charges with no impact on their applications.

Circuit-Switched CDPD's suitability for ITS service is not restricted to areas where CDPD is not deployed, but it also provides an alternative to packet-switched transmission of information for long messages. Examples would be downloading the map of a region, a list of points of interest with detailed descriptions, extensive local yellow-page information, written route guidance, etc.

The CS-CDPD upgrade became available in May 96, although the first modems/phones will not be available before August 96. At the time of this writing, only software prototypes are available. GTE Mobilnet plans to deploy CS-CDPD commercially in the 3rd quarter of 1996.

#### 7.5.1.1.2.1.3 CDPD Next Generation (CDPDng)

The CDPD Forum has already shown interest in investigating higher data rates. Under consideration are ISDN rates (56/64 kbps and possibly 144 kbps). Also on the horizon is the possibility of allowing for "bandwidth on demand", a term that describes the negotiated assignment of a given number of channels to a user to allow for higher data rates.

By keeping the upper layers of the CDPD protocol, and only changing the MAC and Physical layers, most of the infrastructure investment will be maximized. Given the common migration from AMPS to CDMA, it seems very plausible that the new physical layer for CDPDng would be CDMA-based. As with CDPD today, CDPDng would be (CDMA-)voice-friendly. This an area still requiring considerable study.

#### 7.5.1.1.2.2 CDMA (IS-95-A)

In this section, an analysis is presented on data standards based upon the EIA/TIA IS-95-A CDMA, a.k.a. Q-CDMA, standard. IS-95-A defines a 9.6 kbps service, and there is an extension for 14.4 kbps service, termed TSB 174. We examine both circuit-switched and packet-switched CDMA data, even if the former is *a priori* oriented to long "transactions" like voice, and is not expected to compare with packet systems (like CDPD), which were designed specifically for "short" packet data. On the other hand, one cannot yet speak of a full fledged packet-switched service over CDMA. (IS-657, the 9.6/14.4 kbps standard, is still in the ballot process.) **IS-95-A-based short message service (SMS)**. We will briefly mention the ongoing work on High Speed Data Services at the CDMA Development Group (CDG).



Both GRANET and MOSS, the GTE Laboratories simulation tools described in Appendix I and used in Section 8, already have significant CDMA capabilities. However, no simulations of CDMA-based data is appropriate at this moment since their standards are still being developed by the industry.

#### 7.5.1.1.2.2.1 Circuit-Switched Data (IS-99)

The EIA/TIA IS-95-A standard deals mainly with CDMA technology in support of circuit-switched service (speech mode). Analyzed in this section is IS-99, its circuit-switched data derivative, from the perspective of carrying ITS data traffic.

For IS-99, the transfer of a “typical” ITS message on a cellular reverse link, from mobile to base station, entails setting up a CDMA channel, transmitting the message, and then tearing down the connection. The purpose of analyzing this mobile-originated message transfer over the reverse link of IS-95-A, is that its delay performance can be immediately compared to that of a packet system.

Obviously, any ITS service provider would like to perform efficiently. Packet delivery systems are rated based on their delay-throughput characteristics – the calculation of which turns out to be a complex problem. A simpler performance measure in the case of a circuit-switched service is the overhead when carrying short messages (“short” relative to the circuit set-up and tear-down times). The overhead ratio, R, defined as

$$R = \frac{(\text{overhead} + \text{information transmission time})}{(\text{information transmission time})},$$

can be used as a first measure of the efficiency of a circuit-switched service. In what follows, the overhead calculation is performed.

The duration of the calling steps incurred by a mobile originated ITS message is well documented. Four cases are of interest, corresponding to minimum/typical delays and slotted/non-slotted modes. The slotted mode is defined in IS-95-A as a mode in which a registered mobile unit disables most of its functions most of the time (i.e., it “sleeps”) to prolong its battery life. While in this mode, the mobile monitors and updates stored parameters at a low, predetermined rate.

Data delivery on a CDMA circuit-switch involves 3 stages (4 for slotted mode terminals): (0) Access (System Parameters Update for slotted mode terminals); (1) Channel Set-up; (2) Information Transmission; and (3) Tear Down.

To add to the above, there is the processing time both at the base and the mobile. If it is assumed that the processing per operation can be performed in one CDMA frame, the call duration is increased by roughly 180 ms.

Table 7.5-2 shows the duration of each of the call steps incurred in IS-95-A. Even in the best case scenario, and even for non slotted mode mobiles, there is a sizable amount of time spent preparing the data transfer, and at the end in cleaning up. This points out the well known fact that circuit-switched operation begins to make sense when the duration of the transaction significantly exceeds its handling time.

**Table 7.5-2 Typical and Minimum Duration of IS-95-A Call Steps**

**Stage 0: Access System Parameters Update**

Mode	Time [ms] (typical)	Time [ms] (minimum)
Slotted	640	80

**Stage 1: Channel Set-up**

Phase	Time [ms] (typical)	Time [ms] (minimum)
Origination message	240 <sup>5</sup>	80
Channel assignment message	80	80
Mobile acquires fwd traffic channel	40	40
Base acquires reverse traffic channel	40	40
Base acknowledges order message	20	20
Base response order message	20	20

**Stage 2: Information Transmission**

Phase	Time [ms] (typical)	Time [ms] (minimum)
Message Transmission	80	80
Base Acknowledgment	20	20

**Stage 3: Tear down**

Phase	Time [ms] (typical)	Time [ms] (minimum)
Mobile release order	20	20
Base release order	20	20

Table 7.5-3 shows how the overhead ratio is arrived at under typical and optimistic (minimum “overhead”) conditions. The overhead ratios for the so called slotted mode are 8.5:1 (minimum) and 17.5:1 (typical). For the non-slotted mode they would be 7.5:1 (minimum) and 9.5:1 (typical).

**Table 7.5-3 Summary of ITS Call Duration for IS-95-A Circuit-Switched Service (Slotted Mode)**

Phase	Typical Time [ms]	Minimum Time [ms]
Circuit set-up	1080	360
Information Transmission	80+20	80+20
Circuit Release	40	40
Processing Time	180	180
Total duration [ms]	1400	680
Overhead Ratio	1400:80=17.5:1	680:80=8.5:1

<sup>5</sup> In the event two mobile access attempts are needed, after a first failed transmission trial (80 ms) there is a back off time of 80 ms followed by a successful transmission (another 80 ms).

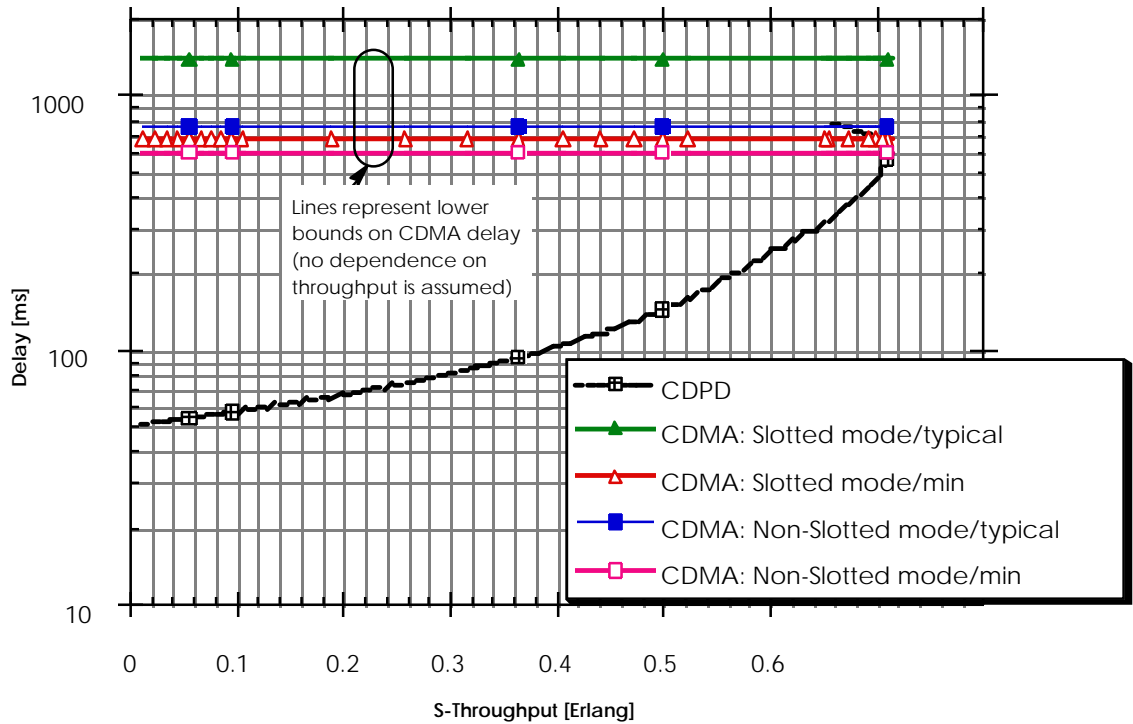
The column marked “Typical Time” in Table 7.5-3 provides:

- Circuit set-up time [ms]:  
Stage I (640) + Stage II (240+80+40+40+20+20) = 1080
- Transmissions of other than ITS payload bits [ms]:  
Stage III (20) + Stage IV (20+20) = 60
- Processing Time [ms] = 180; Total overhead (items 1 through 3) [ms] = 1320;  
ITS message transmission [ms] = 80
- Overhead ratio = (1320+80)/80 = 17.5

The numbers in the previous tables were arrived at in less than an optimistic analysis, which somewhat underestimates the time needed to accomplish certain tasks. That approach therefore yields a total duration figure which lower-bounds the real duration to be expected in the field. Two examples of this optimistic analysis are described below:

1. *Ignored times* — to allow a meaningful comparison with other ITS candidate technologies, the clock is started from the moment the user originates a message transfer. Thus, previous setup times, such as those taken for power up and first initialization, are ignored in the call duration budget.
2. *Shortened access time* — it is assumed that two mobile access attempts (probes) are enough to get the base station response. Field and preliminary analysis suggests that this is typical, but far from worst case.

The comparison with a packet radio system, such as CDPD, does not favor circuit-switched CDMA data. Figure 7.5-7 shows the typical call durations (ignoring the effect of the ITS data load) with the delay curves for CDPD which provides packet-switched service on a random-access protocol platform. For CDPD, at S~0 Erlang, the overhead ratio is by definition 1:1 — given that the reverse link CDPD channel is contention based, if there is no offered traffic, any message will go through without any delay (provided enough C/I is available). Consequently, it is apparent from the figure that the use of CDPD as the platform for ITS will result in equivalent “overhead ratios” varying from 1:1 (at S~0 Erlang) to 9:1 (at S~0.7 Erlang). This is always less than even non-slotted CDMA. It can be seen that even under the most optimistic assumptions, IS-99 remains a grossly inefficient platform for the purpose of carrying the usually small ITS messages.



**Figure 7.5-7 Average Delay/Call Duration Ratio: CDPD versus Circuit-Switched CDMA**

#### 7.5.1.1.2.2.2 CDMA Short Message Service (IS-637)

IS-95-A based CDMA currently has very limited packet-switched data capabilities. The primary limitation is imposed by the reverse link. On the forward link, the paging channel can be used to accommodate outbound traffic, although the maximum data rate is currently restricted to 9.6 kbps under IS-95-A, or 14.4 kbps under TSB-137. On the reverse link, two mechanisms exist which can be used to facilitate data traffic.

The existing IS-95-A channel structure associates a group of reverse access channels with a single forward paging channel. The paging channel is used to carry system configuration information as well as user data. Up to seven paging channels can be supported currently, each delineated within a cell sector by a separate Walsh code. Different sectors within the network are delineated by covering all channels in the sector with a complex valued pilot code. The modulation employed on the paging channel is essentially BPSK, using data rates of either 4.8 kbps or 9.6 kbps. Currently, there are 64 Walsh codes for channelization on the forward link. Extensions permitting each Walsh code to be reused to facilitate greater capacity and/or data rates have been proposed. The paging channel is currently segmented into fixed 80 ms slots.

Associated with each paging channel are 32 reverse link access channels. Access channels are chosen at random by users and are delineated by non-orthogonal codes. The codes within a sector are a function of the sector pilot code, paging channel code and the access channel chosen. The random access protocol employed is based on slotted ALOHA, with the slot size being a system configurable parameter. The parameters governing the protocol permit additional randomization of packets through time offsets to further reduce the possibility of collisions. All packets employ a minimum of 20 ms (one frame) of unmodulated preamble to allow for acquisition by the base station. The access channel data rate is currently fixed at 4.8 kbps, with 64-ary orthogonal modulation being employed.

For long messages, as we have discussed, negotiation of a dedicated traffic channel is warranted. While the traffic channel is capable of supporting 9600 bps sustained, the set-up times can be prohibitively long for short messages (~800 ms), as reviewed in the previous section.

Short messages of 110 bytes or less can be accommodated by using the one-way data burst message on the access channel. The peak data rate supported by the access channel is, as mentioned above, 4.8 kbps.

#### 7.5.1.1.2.2.3 Packet-Switched Data (IS-657)

A new packet-switched data standard over CDMA (IS-95-A and TSB 174) has already been submitted to ballot. Service Option 7 provides generic PPP support for packet data services. An accompanying Service Option 8, which would have supported CDPD networks was vetoed by Lucent Technologies (ex-AT&T) pending clarification of Intellectual Property Rights (IPR) associated with the CDPD standard, and TIA's recognition of the CDPD standard. In any case, the support of PPP allows for interaction between the two networks.

The main limitation of this packet data service is its data rate, limited to 9.6 kbps for IS-95-A or 14.4 kbps for TSB 174, significantly less than the 19.2 kbps of CDPD.

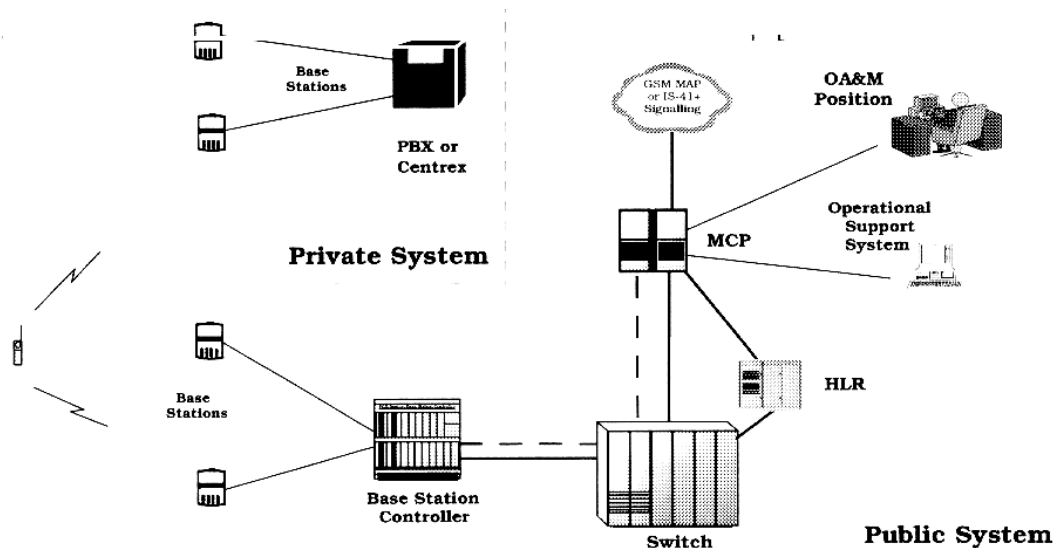
#### 7.5.1.1.2.2.4 High Speed Data Services over CDMA

The CDMA Development Group (CDG), an autonomous organization of CDMA manufacturers and future carriers, is already in the process of standardizing the future high speed data services, both circuit-switched and packet-switched, over CDMA. The goal is first to standardize the 64 kbps services, and then define multimedia data services at 500 kbps, and eventually at 1-2 Mbps. Unfortunately, any of these new data services will definitely require re-designing the CDMA physical layer, and thus imply still a long process.

#### 7.5.1.1.2.3 *Omnipoint's Hybrid CDMA/TDMA/FDMA System (IS-661)*

Omnipoint's PCS proposal is now an official industry standard under the designation IS-661.

Omnipoint's system can be integrated into either the GSM or AIN switching networks. It also allows for the use of IS-41 inter-operability for roaming and system interconnection. In addition, the handset can operate with both (GSM and AIN) networks, which enables easy roaming and inter-operability. The system also provides inter-operability with indoor, low-cost, privately owned systems that offer wireline quality voice and high data rates, while providing for full vehicle mobility (up to 65 mph) and ubiquitous coverage. A high level architecture for Omnipoint's system is depicted in Figure 7.5-8.



**Figure 7.5-8 Omnipoint's System Architecture and Public-Private Operation**

Omnipoint's system attempts to combine the major advantages of CDMA, TDMA, and FDMA in a hybrid solution. All signals employ a proprietary spread spectrum modulation waveform. Within a cell, multiple access at the data level is achieved through time division (TDMA). Either time-division duplexing (TDD) or frequency-division duplexing (FDD) can be used. In a standard configuration this technology provides 9.6 kbps full-duplex service to 16 simultaneous users in a single 1.875 MHz channel (or 32 users in 3.75 MHz). The 9.6 kbps reflect user throughput after all overhead for addressing, error checking, etc.

Adjacent cells are set to different frequency channels (FDMA) under a nominal N=3 frequency reuse architecture (like in GSM). Cells beyond those immediately adjacent use a variety of separation techniques, including different PN codes (CDMA), power control, directional antennas, and Time Slot Interchange (TSI) for additional inter-cell isolation. By utilizing a TDMA approach within a cell, and not relying solely on CDMA for separating multiple mobile signals at the base station, self-interference at the receiver is greatly reduced, permitting greater area coverage for a given mobile transmitter power.

Unlike CDMA-only architectures, cell sizes remain constant as a cell becomes loaded near capacity. CDMA is used in the Omnipoint system to mitigate multipath while providing high data rates, and to achieve better C/I ratios for inter-cell isolation.

Omnipoint's TDMA structure is based on a 20 ms polling loop for mobile access to the base station. In the 1.875 MHz per RF channel version, the system provides 32 simplex time slots, each of 9.6 kbps, or 16 paired, 9.6 kbps full-duplex time slots per RF channel. In the 3.75 MHz version, a single RF channel supports 64 simplex time slots or 32 full duplex users each at 9.6 kbps. There are provisions for each mobile to aggregate multiple time slots, giving users more bandwidth for higher data rates as required, to a maximum data rate of 153.6 kbps (higher than the 144 kbps of ISDN) full duplex per 1.875 MHz channel.

In fact, the Omnipoint system is reported to support data rates from Short Message Services to ISDN data rates and higher. In its 1.875 MHz version it can support over 144 kbps full duplex and over 256 kbps simplex. In the 3.75 MHz version it can support over 256 kbps full duplex or 512 kbps simplex. Note, however, that these higher data rates can only be achieved if the time slots are not in use by someone

else, which is not what the system is designed for. Moreover, no data protocol has been defined or selected for this variable rate data service.

In addition to the user voice/data channel, the system provides for a D channel that allows for continuous 400 bps data traffic for every user. This channel is separate from (but simultaneous with) the bearer channel for messaging even when the handset is in use. The D channel can carry information for applications such as paging, voice mail notification, and Short Message Service.

The Omnipoint system is frequency agile in the entire 1850-1990 MHz band, including the unlicensed band (1910-1930 MHz) recently allocated to PCS by the FCC. It can also make use of the unlicensed band at 2.4-2.483 GHz). This aspect enables the system to be simultaneously used as an outdoor mobile, with in-building PBX, key system, or Centrex, or as a residential cordless phone.

Omnipoint's base stations are very small (as small as 27"x15"x13"), and light (less than 100 pounds), enabling them to be pole-mounted on street lights, or telephone/utility poles, or attached to the sides of buildings. The cell radius varies from 100 feet to 10 miles, depending on the environment (urban, suburban, rural) and the height of the antennas used.

Omnipoint was granted a Pioneer's Preference 30 MHz PCS license to compete in the New York Major Trading Area (MTA). The IS-661 system will apparently be launched on top of a GSM (PCS 1900) system Omnipoint will deploy soon.

#### *7.5.1.1.2.4 PCS 1900 (GSM/DCS 1800)*

Another technology candidate that requires evaluation is GSM, the well established Pan-European cellular standard. Actually, the American version of its DCS 1800 incarnation, PCS 1900, is what is proposed for evaluation here. The recent PCS auction results make it essential to analyze the proposed GSM solution. Pacific Bell Mobile Services, Bell South Personal Communications, American Personal Communications (APC), Western Wireless Co., Intercel, American Portable Telecommunications, and Omnipoint recently formed the North American Interest Group of the GSM MoU, and are all adamant to deploy GSM as soon as possible. Together, this group holds licenses to cover over 125 million people, including 12 of the top 25 cities in the U.S. In fact, APC, teamed with the Sprint Telecommunications Venture (a partnership between Sprint and the nation's largest cable companies), recently deployed the first commercial PCS systems in Washington, DC, Maryland, and Virginia, with a population base of more than eight million people.

In addition to voice, GSM offers certain data capabilities under the form of short message services (SMS). Besides SMS, the recent availability of circuit-switched data equipment will also be analyzed for its suitability to ITS services.

Within the scope of GSM Phase 2+, still in progress and under no disclosure at ETSI (European Telecommunications Standards Institute), a true packet data service is being designed for use with GSM, namely GPRS, General Packet Radio Service. Similarly, a High Speed Circuit Switched Data (HSCSD) standard is in the works. Both will be briefly discussed below.

##### *7.5.1.1.2.4.1 GSM System Description*

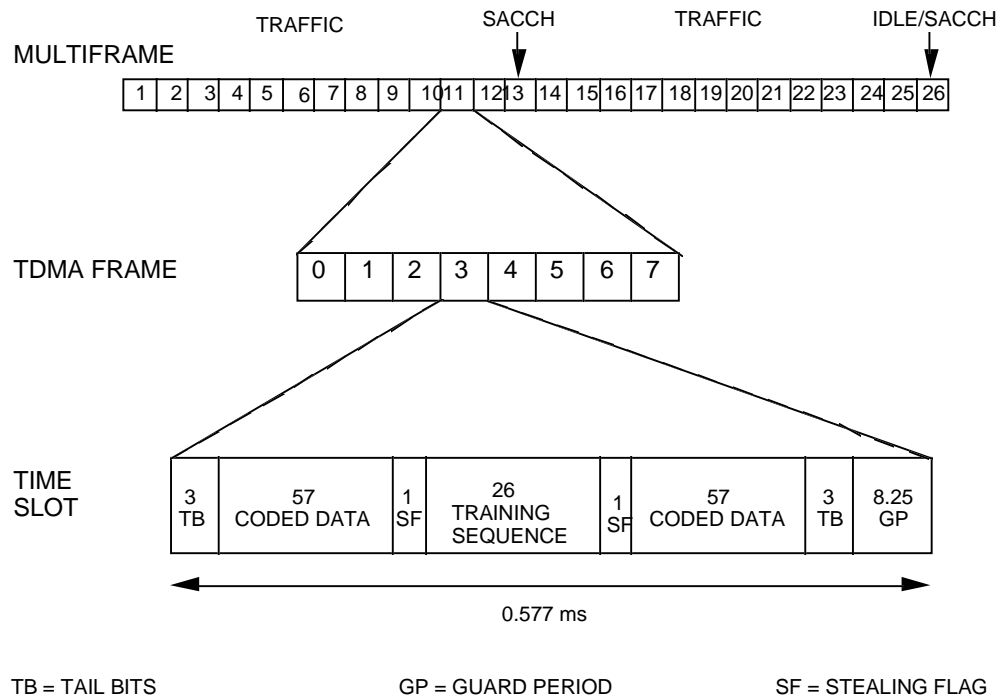
GSM (initially named after the standards body that conceived it, Groupe Speciale Mobile), now standing for Global System for Mobile Communications, refers to the Pan-European standard for digital cellular mobile telephone service. This system is being deployed throughout Western Europe, replacing first generation mobile systems conforming to five different incompatible standards, and has enjoyed considerable success in many countries (128 have already signed agreements to deploy GSM systems).

GSM, which operates in the 900 MHz frequency region, will not be deployed in the United States. However, in the form of PCS 1900, which is essentially GSM Phase 2 (or DCS 1800) re-configured to operate in the 1900 MHz band, it is a strong contender for future PCS service in the United States. There are a number of small differences between GSM and DCS 1800, the most important of which is that the transmitted power levels of DCS 1800 are lower to promote the deployment of smaller cells.

There are eight (full rate) voice channels per GSM carrier with the capability to introduce half-rate codecs in the future. The carrier spacing is 200 kHz. As deployed in Europe there is a total bandwidth of 25 MHz giving 125 radio channels or 1000 (one-way) traffic channels. (Spectral allocations in the United States for PCS will be 10, 20 and 30 MHz.)

The frame and slot structure of GSM is shown in Figure 7.5-9. A TDMA frame consists of eight time slots of length 0.577 ms. A multi-frame consists of 26 TDMA frames, 24 of which carry traffic. The gross bit rate is 270.8 kbps giving 33.85 kbps per user which is used as follows: (1) 13.00 kbps for Codec Voice; (2) 9.80 kbps for Error Protected Speech; (3) 0.95 kbps for SACCH gross rate; and (4) the equivalent to 10.10 kbps for Guard Time, Ramp Up, and Synchronization.

There are two control channels associated with the traffic channels. The fast associated control channel (FACCH) is a blank-and-burst channel and replaces a speech block whenever it is used. Two frames of the multi-frame are allocated to the slow associated control channel (SACCH). With full rate users the second SACCH frame is idle. In a SACCH frame the slots are assigned in the same way as for traffic frames. The gross bit rate on this channel is 950 bps and the net rate is 383 bps.



**Figure 7.5-9 GSM Frame and Slot Structure**

#### 7.5.1.1.2.4.2 GSM Short Message Services (SMS)

In addition to voice and circuit-switched data services, GSM will provide certain packet data capabilities known as short message services (SMS). There are three distinct services offered under SMS. Point-to-point short message service is divided into mobile-originated and mobile-terminated categories with a



service center being one of the endpoints in both cases. The two services can be combined to form a mobile-to-mobile service via the service center. The messages in these services are limited to 160 characters and are carried in control channels. The third category is cell broadcast SMS which allows messages to be broadcast on the control channel. Message length is limited to 93 characters. However, there is a provision to concatenate 15 such messages of 93 characters each. Unlike point-to-point SMS, a mobile may not be able to receive a message broadcast on the control channel if it is in the middle of a call. However, this service has not been fully defined or implemented yet.

The point-to-point short messages services described above are carried in what is known as the slow access control channel (SACCH) which occupies one frame out of the 26 in the GSM multi-frame structure. The SACCH frame, like traffic frames, is composed of eight time slots. In a SACCH frame the time slots are assigned in the same way as for traffic frames. That is, one is dedicated to each of the eight voice channels. Thus, a digital message can be transferred efficiently if a voice call is in progress. However, use of the short message service in the absence of an existing voice call is rather inefficient, since the time slots normally used by the voice call would be unused.

#### 7.5.1.1.2.4.3 Circuit-Switched Data

Unfortunately, only scant information is available. The manufacturers promote the equipment as *adapters* (no longer modems!) that allow the user to send faxes and data at up to 9.6 kbps over the GSM air-interface. The users can retrieve e-mail messages through a connection to their Internet service provider of choice, but do not have full IP capabilities -- the adapter does not have an IP address.

#### 7.5.1.1.2.4.4 High Speed Circuit Switched Data (HSCSD)

A High Speed Circuit Switched Data (HSCSD) transmission mode is currently being standardized at ETSI. HSCSD is a GSM bearer service intended to use multiple consecutive time-slots for increased data rate over the GSM air interface.

#### 7.5.1.1.2.4.5 General Packet Radio Service (GPRS)

A new packet-switched data service over GSM, General Packet Radio Service (GPRS), is in the workings at ETSI. The standardization process is still under way, and only preliminary, vague information is available. A comparative study of this new packet data system (and its associated network) with CDPD would be quite instructive. Two things, however, seem certain. First, each data channel cannot provide more than 9.6 kbps, and to get higher throughput two or more TDMA time slots within a GSM carrier frame have to be used. A similar concept is proposed in CDPDng, except that each CDPD channel has now 19.2 kbps, and each CDPDng channel will have 56/64 kbps.

#### 7.5.1.1.2.5 Private Mobile Data Networks

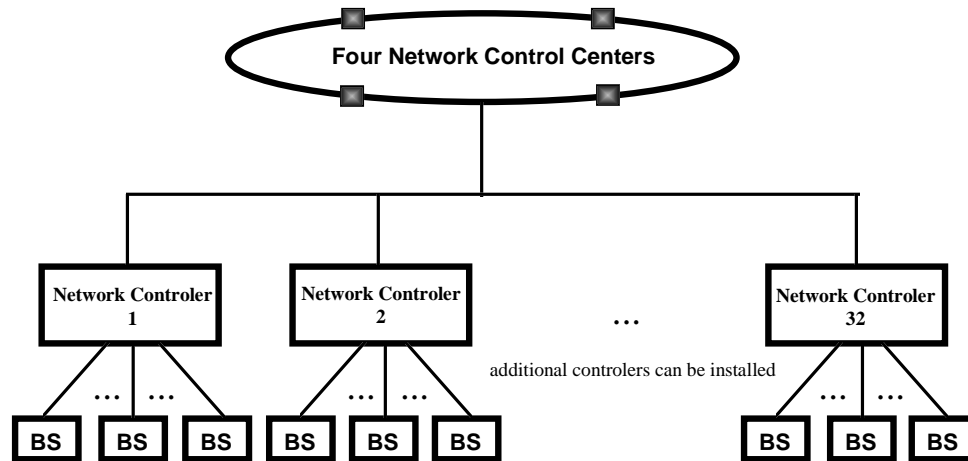
A few data systems exist in the land-mobile radio (LMR) 800-900 MHz band (in fact, part of this band is SMR), mostly of a proprietary nature. To the extent possible, these proprietary systems will be analyzed briefly, with emphasis on capacity, availability, and coverage. The most important ones, in terms of coverage, are ARDIS and RAM. (RAM effectively operates in the SMR band.)

#### 7.5.1.1.2.5.1 ARDIS

ARDIS (Advanced Radio Data Information System) is a two-way packet radio service. It was launched in 1983 as a joint venture between IBM and Motorola, and is now a wholly-owned subsidiary of Motorola. ARDIS is deployed in 400 metropolitan areas (see example of coverage in Figure 7.5-10), reaching over 90% of the urban business population, and 80% of the total U.S. population including Alaska, Hawaii, Puerto Rico, and the U.S. Virgin Islands. ARDIS has 45,000 users in the US, and another 7,500 in Canada, serviced by Bell-ARDIS, a subsidiary of Bell Mobility Canada. IBM is still ARDIS' largest customer, with more than 12,000 field engineers using the service.



The ARDIS network (Figure 7.5-11) consists of four network control centers with 32 network controllers presiding over 1250 base stations. Remote users access the system from laptop radio terminals that communicate with the base stations. The backbone of the network is implemented with leased lines. The four ARDIS hosts (Chicago, New York, Los Angeles, and Lexington, KY) serve as access points for a customer's mainframe computer, which can be linked to an ARDIS host via async, bisync, SNA or X.25 dedicated circuits.



**Figure 7.5-11 ARDIS Network Architecture**

The system architecture is cell-based, with cells overlapped to increase the probability that the signal transmission from a portable will reach at least one base station. The base station power is 40 W, and the cell radius extends to 10-15 miles. Portables operate with 4 W radiated power. The overlapping coverage, combined with error-correcting coding ensures that ARDIS can support portable communication from inside buildings, as well as on the street.

ARDIS uses a concept known as single frequency reuse, where all cells in a given area share a single frequency. While the use of overlapping coverage, and the same frequency, does provide for reliable radio connectivity, it raises the problem of interference when signals are transmitted simultaneously from adjacent base stations. To deal with this, ARDIS turns off neighboring transmitters for 0.5 to 1 second when a forward link transmission occurs. The system uses very little spectrum, but single frequency reuse significantly limits system capacity.

ARDIS operates in the 806-821 MHz (reverse link) and 851-866 MHz (forward link) bands, and the channel bandwidth is 25 kHz. The multiple access method is FDMA.

ARDIS has recently implemented nation-wide roaming and is in the process of raising the data rate in a few markets to 19.2 kbps (8 kbps of user information) from 4.8 kbps. Initially, ARDIS offered MDI's (Mobile Data International Inc.) proprietary MDC-4800 protocol that achieved only 4.8 kbps on the 25 kHz channel using FSK modulation. Recently, Motorola developed and began offering its proprietary RD-LAP protocol for ARDIS, offering 19.2 kbps on the same channel using QFSK – with significantly less overhead, nationwide roaming, more robust link layer protocols and coding schemes, and better overall message throughput. Today, the ARDIS network accepts both protocols and offers modems that can be configured for either of them.

The laptop terminals access the network using *digital-sense* multiple access (DSMA). Essentially, a remote terminal listens to the base station transmitter to determine if a "busy bit" is on or off. When it is off, the terminal is allowed to transmit (very much like in CDPD). However, if two remotes begin to

transmit at the same time, the packets may collide, and re-transmission will be attempted. Unlike CDPD, however, the system does not have Collision Detection. Therefore, the system has to reject the garbled packets and it will take a certain time for the remote terminals to realize that such an event took place. The busy bit only lets a remote terminal know when other terminals are transmitting, thus reducing the probability of packet collision, but does not allow the system to “immediately” react to collisions.

As a packet switched data network, ARDIS carries only data, and does not offer any voice integrated products. The packet length is 256 bytes. The service is suitable for transmission of files up to 10 kbytes long. ARDIS is used in support of computer-aided dispatching, such as is used by field service personnel, often when they are at a customer’s premises.

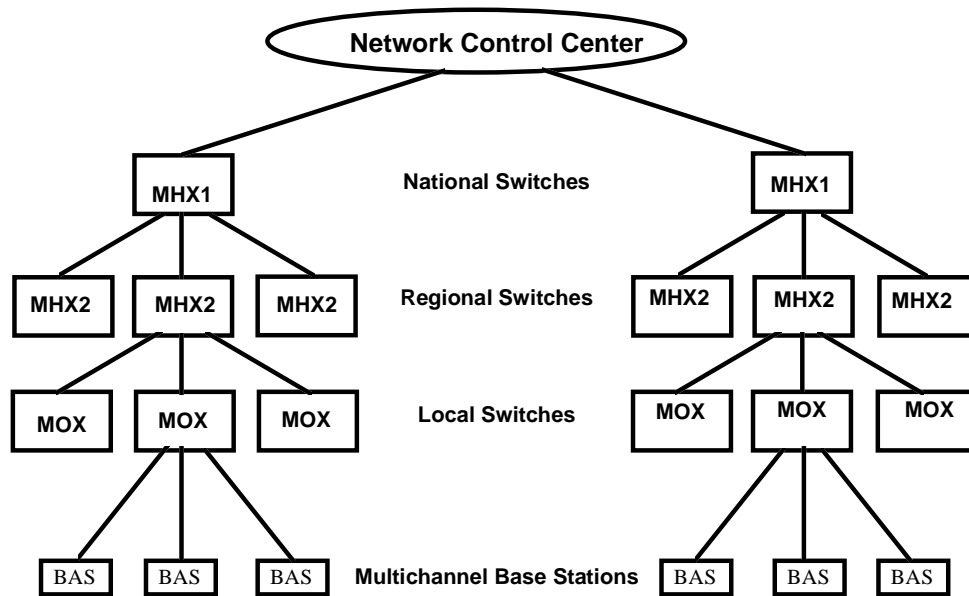
#### 7.5.1.1.2.5.2 RAM

RAM Mobile Data, a joint venture of Bell South and RAM Broadcasting Corporation, introduced the Mobitex system in 1991 in the U.S. Today, the network covers almost 100 metropolitan areas, and has around 30,000 users in the U.S., with another 2500 in Canada serviced by Cantel Data (Rogers Cantel). RAM plans to cover most of the U.S. business population, and is targeting the mobile professional.

The Mobitex system is a nationwide, interconnected trunked-radio network developed by Ericsson and Swedish Telecom. The first network that went into operation was in Sweden in 1986; other networks have been implemented in the meantime in a growing number of countries including Norway, Finland, Canada, UK, France, Germany, Netherlands, Belgium, Poland, Australia, Korea, Singapore, Chile, Nigeria, and recently Mexico. The Mobitex system specification is managed by the Mobitex Operators Association (MOA).

While the system was designed to carry both voice and data, the U.S. and Canadian networks are used to provide data only.

The Mobitex network architecture is hierarchical, as shown in Figure 7.5-12. At the top is the Network Control Center, from which the entire network is managed. The top level of switching is the national switch (MHX1) that routes traffic among service regions. The next level comprises regional switches (MHX2), and below that are local switches (MOX), each of which handles traffic within a given service area. Many reliability features are implemented, such as alternate network pathways, autonomous operation at each network level, multiple connections between nodes, and a backup network control center.



**Figure 7.5-12 MOBITEK Network Architecture**

Mobitex uses packet-switching techniques to allow multiple users to share channels. Message packets are switched at the lowest possible network level (only billing information is sent up to the network control channel).

The Mobitex system operates in much the same way as a cellular telephone system, except that hand-offs are not managed by the network. When a radio connection is to be changed from one base station to another, the decision is made by the mobile terminal, not by the network intelligence. To access the network, a mobile terminal finds the base station with the strongest signal and then registers with that base station. When the mobile terminal enters an adjacent service area, it automatically re-registers with the new base station, and the user's whereabouts are relayed to the higher-level network nodes, providing for the roaming capability. Other features include broadcast and store-and-forward messaging.

RAM operates in the SMR band (896-901 MHz for the reverse link; 935-940 MHz for the forward link), in 12.5 kHz channels. The system's transmission rate is 8 kbps half duplex, and the modulation is GMSK. Block interleaving, forward-error correction (FEC), as well as selective ARQ, are used to ensure the integrity of the delivered data packets. A reservation slotted-ALOHA-type scheme is used for channel access, providing a good balance between efficiency and responsiveness.

RAM supports existing standards such as X.25 and TCP/IP through gateways, since it is based upon proprietary protocols. Mobitex uses a proprietary network layer protocol (MPAK) with up to 512 bytes of user data per packet, and 24 bit addressing (Mobitex Access Number). A transport protocol, MTP/1, also proprietary and optimized for the mobile radio environment, was introduced by the MOA to facilitate development of multi-packet applications. The standard, proprietary Mobitex terminal interface, MASC (for Mobitex ASynchronous Communication), provides for reliable transfer of data to/from, and the control and status monitoring of the modem.

#### 7.5.1.1.2.6 ESMR

Specialized Mobile Radio (SMR), began as an analog system which is still used today mainly for dispatching of buses and taxis. Most SMR providers cover only a relatively small area, though many do offer some sort of networking and interconnection with the public telephone network. Roaming under SMR is less user friendly than under cellular, and though it is technically possible to send data over SMR, it is not practical; SMR mainly offers wide-area analog voice dispatch service.

Enhanced SMR (ESMR) uses digital technology to allow more users per channel and to increase the number of services available to a user. ESMR providers such as Nextel, Dial Page, and CenCall own licenses to SMR frequencies across the country.

Some of the services provided by ESMR are dispatching, cellular-like mobile phone service, alphanumeric paging and messaging, and eventually other data services. An (E)SMR cell is larger than a cellular telephone cell, meaning that it will be cheaper to cover a particular area, but the available capacity will be smaller. A disadvantage of ESMR is that the handsets are more expensive and bulkier than current cellular phones, because of the new technology involved and the integration of voice and data into one unit.

As with the mostly proprietary systems above, to the extent possible, the ESMR systems will be briefly analyzed, with emphasis on capacity, availability, and coverage. The main data entry is, at the moment, Geotek's, since Nextel has not yet clarified its data options.

##### 7.5.1.1.2.6.1 Nextel

Nextel Communications Inc., after completing the acquisition of Dial Call Communications Inc., OneComm Corp., and American Mobile Systems Inc., as well as Motorola's SMR licences, and after getting Geotek's network (in exchange for 900 MHz spectrum), owns FCC licenses to a potential customer base of 180 million people. Nextel, the only nationwide SMR provider, already has 916,000 subscribers (approximately 80% of the total). Their plan is to build a nationwide digital network to compete with cellular voice. No plans to provide *packet* data service have been announced yet, but they have circuit switched data and fax capabilities.

##### 7.5.1.1.2.6.2 Geotek

Geotek uses a proprietary Frequency-Hopping Spread Spectrum system to provide circuit-switched voice and data, as well as packet data services. The packet data service is TCP/IP based, and an option to provide CDPD compatibility is in preparation. Geotek's macro cellular system supports hand-off, and provides 9.6 kbps raw data rate.

Services offered are cellular-type voice, half-duplex dispatch, full-duplex private telephony, two-way messaging, and data dispatch. Geotek has already deployed its system in Philadelphia, New York, Baltimore, Washington, DC, and Boston, and is now deploying in Miami.

The network can provide information to mobile users through the Geotek Mobile Workstation and a top-of-the-line device that combines the functions of a cellular phone, two-way radio, pager, and PDA, or through a simple add-on to a cellular phone.

##### 7.5.1.1.2.7 220 MHz

The 220 MHz service is a land mobile radio service that may be used for either commercial or private purposes. The service consists of two hundred 5 kHz paired channels, some of which are licensed on a national basis and some on a "local" basis. One hundred of the two hundred channel pairs are licensed as

five-channel trunked systems on a local basis. There are few restrictions as to the type of service that may be provided by these systems. Some view this service as a potential competitor to PCS, cellular, or wide area SMRs, but the limited channel capacity will hinder its competitiveness unless license consolidations occur in the future.

#### 7.5.1.1.2.8 *Narrow-Band PCS*

Two-way paging or messaging systems are among the first services that will utilize the Narrow-band Personal Communication Services (PCS) frequency band. The Federal Communication Commission (FCC) defines Narrow-band Personal Communication Services (PCS) as a family of mobile services that includes advanced voice paging, acknowledged paging, data messaging and both one and two-way messaging on a nationwide, regional, major trading area, and basic trading area basis. The FCC has licensed Narrow-band PCS at 901-902 MHz, 930-931 MHz, and 940-941 MHz. Six companies have paid a total of \$617 million for 10 nation-wide, narrow-band PCS licenses for channels in the 930 MHz band. The Narrow-band PCS providers include: AirTouch Comm. Inc., Bell South Wireless Inc., Destine Corp. (in fact MTel), McCaw Cellular (now AT&T Wireless), Pagenet, and Pagemart.

##### 7.5.1.1.2.8.1 Two-Way Paging

SkyTel is presently offering the first two-way messaging service. This service uses Motorola's ReFLEX<sup>TM</sup>50 two-way transport protocol, and the Tango<sup>TM</sup> 2-way pager. SkyTel offers paging service in approximately 300 markets; two-way paging is being deployed nationwide, and is offered now in the top markets.

Fundamentally, a two-way messaging service is similar to the existing paging services with an addition of a response channel. Applications include: message reply, message initiation, and control actions such as automatic registration and acknowledgment.

A two-way paging/messaging system is not an interactive system. The messages are stored, queued, and then sent to the subscriber. Therefore, the system has an inherent delay that can be on the order of many seconds to a few minutes. Such a system is clearly not suitable for supporting ITS messages that require real-time response. However, 2-way messaging may suffice for personal access type messages that don't require immediate response and are not time critical.

The candidate ITS messages that could utilize two-way paging are those with the following attributes:

- Short (up to 500 characters)
- Messages that can be responded to using a set of canned responses
- Messages that can tolerate long delays and do not require real time response
- Messages that are not time critical

Tables 7.5-4 and 7.5-5 provide the specifications of SkyTel's paging/messaging service and Motorola's Tango<sup>TM</sup> 2-way paging unit.



**Table 7.5-4 SkyTel 2-Way Paging Service Specifications**

Features	Specifications
Message type	Text and binary
Maximum Message size	500 character per transmission
Broadcast Rate (update)	The message is transmitted once every 5 minutes for the 1 <sup>st</sup> hour, and once every hour for the next 72 hours
Coverage	Over 100 markets -coverage will be similar to regular paging
Hardware Cost	\$400 for the Motorola Tango™
Present Service Cost	\$40 to \$90 per month (wide area, regional and nationwide) 200 messages free (80 characters per message) \$.5 for each additional message
Capacity	Similar to paging
Interface Methods to a subscriber	Telephone keypad, Operator, computer interface (i.e. modem), alphanumeric pager, Tango messaging unit, Electronic mail, and Message Duet system
Subscriber Respond Methods	<ul style="list-style-type: none"> <li>• Selecting a response from a set of pre-programmed responses</li> <li>• Selecting a response from a set of multiple choice options that are included in the message</li> <li>• Using a palmtop to respond or initiate a message.</li> </ul>

**Table 7.5-5 Motorola's Tango™ Two-Way Messaging Unit Specifications**

Features	Specifications
Frequency Band	Receiver 940-941 MHz (Narrowband PCS) Transmitter 901-902 MHz
Channel Spacing	Receiver 25 kHz Transmitter 12.5 kHz
Bit rate	Receiver 6.4 kbps Transmitter 9.6 kbps
Signaling Format	QFSK
Received message type	Numeric (4 bit data), alphanumeric (7 bit data), or binary data (8 bit). 8 bit systems are used for transmission of long messages.
External interface	Serial RS 232 interface for initiating messages and sending long messages using a palmtop computer
Message Memory	100k bytes
Canned Messages	Up to 120 preprogrammed messages

#### 7.5.1.1.3 Satellite Systems – A Survey

During the next few years, many companies are planning to launch hundreds of satellites designed to provide wireless communications to mobile users virtually anywhere on the globe.

Proposed systems will offer voice and data, or data only. Most will also offer position determination. The different systems will determine the position of the user by various techniques, some more accurate than others. Even without a radio location service built into the system, the user terminal may be integrated with a GPS engine. It is important to assess those proposed systems in what they can offer for ITS users in remote or poorly-serviced areas.

This section first compares the advantages and disadvantages of satellite-based versus terrestrial-based mobile radio networks. Then, the different orbits and the different communication subsystem types are characterized.

The many proposed satellite systems are briefly analyzed, focusing mainly on their data capabilities. Currently operating satellite systems are also analyzed, including those providing positioning, like GPS and GLONASS.

#### *7.5.1.1.3.1 Terrestrial versus Satellite Mobile Radio Networks*

Terrestrial-based networks offer obvious, distinct advantages over satellite-based systems. These advantages stem from the much shorter distances between the mobile terminals and terrestrial base stations compared to distances in the order of 200 to 36,000 km, over which satellite mobile terminals must operate. Terrestrial base stations are easier and cheaper to plan, deploy, and integrate into the network than satellites. In comparison, a satellite system lacks the flexibility for adding more and more channels as a function of traffic increases.

The relative advantages that are likely to hold for terrestrial mobile networks include:

- Cheaper and smaller terminals and lower call charges
- Superior radio coverage in urban and in-building areas
- Minimal signal propagation delay
- Greater network capacity

However, satellite-based networks can exploit a few advantages, such as:

- Wide-area coverage
- Network flexibility
- Broadcast capability

Wide-area coverage enables satellite networks to offer services nationally to customers who operate in rural areas. This may be at the expense of greater call charges and more expensive radio equipment than conventional terrestrial services. However, it is possible to offer a diverse range of services using the inherent flexibility of satellite systems. By increasing the mobile terminal's usefulness, effectively one can expect user charges to be lowered. This enables the satellite service to not only complement, but also to compete against terrestrial mobile radio networks in certain market segments.

This is the bet on which all the proposed satellite systems are based. Industry analysts, however, think the market is not big enough to accommodate the proliferation of satellite offerings, and that in the end only a few will survive.

In any case, customers will naturally seek the cheapest, most reliable mobile communication system that meets their requirements. In high density population areas, terrestrial networks offer unbeatable advantages. Therefore, mobile satellite services can be expected to be complementary to terrestrial-based services, primarily in outlying areas.

#### *7.5.1.1.3.2 Orbits: Acronyms and Characteristics*

The most frequently chosen orbit for communication satellites has traditionally been the geostationary earth orbit (GEO), a unique circular orbit in the equatorial plane at an altitude of 35,786 km. Geostationary satellites can cover large areas of the globe and allow fixed pointing ground stations. Three such satellites would, in principle, be enough to cover the whole earth. However, they require high transmitter powers and large antenna apertures. They produce long communication delays, and require high cost and high risk satellite launches. Moreover, they do not properly cover high latitude regions of the earth. In fact, one deficiency of the GEO satellites is the low elevation look-up angle at higher latitudes, such as in Alaska and North Canada (and Northern Europe as well). These areas require link margins of 20-30 dB to overcome blockages. Also, most of the Arctic and Antarctic regions do not have any coverage from GEO satellites.

Looking at the link budget for a satellite link, four terms can be identified:

1. Transmitter EIRP
2. Path Loss
3. Fade Margin + required C/No + Boltzman constant
4. Receiver G/T

In essence, the design of any satellite link involves consideration of the division of relative performance requirements between the satellite repeater and the ground terminals. Given that path loss is practically a constant (or is upper bounded) for a given orbit and frequency band, the important design parameters are the G/T ratios and the EIRP values of the satellite and the earth terminals. These are determined by the antenna gains, receiver noise, and transmitter power, which then become the design variables.

Each communication satellite system design represents one solution to the cost/performance trade-off for the system – taking into account the postulated population of terminals. The history of satellite communications began with small, low performance satellites and a few very large earth stations. Over the years, satellites have grown in function and size. Earth terminals have decreased in size but increased in numbers. These trends are due to the fact that the savings made on a large population of terminals can offset the cost of satellite improvements.

The recent concept of Personal Communication Systems (PCS), however, requires a new approach to the equation. PCS terminals will be required to have small antennas, low output power, and high equivalent system noise temperature, i.e., they will be preferably hand-held terminals with very low EIRP and G/T ratio. Such a requirement presents a new challenge in system design.

There are three possible solutions to the problem of utilizing miniature terminals in satellite communications. The first is to further improve the performance of the satellite itself to compensate for small terminals. Some limitations exist to this approach, however. For instance, satellite receiver noise performance is limited by the noise temperature of the antenna looking at the “warm earth”. Moreover the satellite transmitter power is limited by the satellite power supply capability, a function of its mass. If a spot beam approach were used, increasing the satellite antenna gain (i.e., its size) would improve both G/T and EIRP. However, the antenna size is restricted by the launch vehicle cargo capability, and by the antenna mass, complexity, and cost. In summary, increasing the satellite G/T and EIRP, with the associated build-up in satellite mass and cost, may not be the most cost effective solution for the PCS design.

A second solution would be to use a frequency band at which even the small antennas would have high enough gains. For example, at the Ka-band (26-40 GHz), antenna gains of 20-25 dB can be achieved with small portable antennas. The use of such frequencies would also enable a GEO satellite cellular system to utilize a high number of cells with a satellite antenna array of moderate size and mass. The current availability of higher frequency bands mitigates in favor of this solution. However, several problems present serious impediments for such an approach. These include path loss increase with frequency, low power efficiency of Ka-band transmitters, dependence of link availability on weather, lack of technology, incompatibility with existing and projected terrestrial PCS systems (1900 MHz band).

A third, radically different solution is to decrease the path loss by bringing the satellite closer to earth, by placing the satellites in lower orbits. In return for the advantages of lower path loss and shorter communication delays, this technique unfortunately presents several disadvantages. Instead of the three satellite geo-stationary constellation, many such non-geo-stationary satellites are required in order to provide coverage equivalent to that of the geo-stationary system. The associated control telemetry and network management systems become quite complex. In addition, high Doppler frequency shifts are introduced into the satellite-terminal link, since the satellite is no longer fixed relative to the terminal.

Furthermore, inter-satellite cross links may be required for coverage extensions. Still, such a solution has potential for reducing the cost of a satellite-based PCS system, and it is, as shown later, the preferred choice within the proposed satellite systems.

The non-geostationary orbits are grouped as either low earth orbits (LEO), medium earth orbits (MEO), or highly elliptical orbits (HEO) as shown in Figure 7.5-13. LEO are those in the range 200-3000 km between the so called constant atmospheric density altitude and the Van Allen radiation belts. MEO start above 3,000 km, and extend up to GEO. Satellites in these orbits cross the radiation belts, and thus face high radiation levels.

Finally, HEO can put the satellite within several hundred kilometers of the earth's surface, during its inactive phase, and then take it even beyond the GEO, during its active phase. All elliptical orbits have two characteristic points: the perigee, point of closest approach to the earth, and the apogee, the point farthest from earth.

The choice of optimum satellite orbit is usually determined by the intended earth coverage. All stable orbits can be divided into four classes:

1. Inclined<sup>6</sup> Circular geosynchronous<sup>7</sup> orbits
2. Inclined Elliptical geosynchronous orbits
3. Non-synchronous orbits of the above two and the equatorial type
4. Geostationary<sup>8</sup> orbits

Not all orbits are suitable for communications. Non-synchronous orbits are seldom used for commercial communications, although they may be preferred for defense and scientific applications. Class 1 circular LEO and MEO orbits are particularly suited for cellular mobile communications, since the cell sizes remain constant throughout the orbit. Constellations of geosynchronous satellites in polar and/or inclined circular orbits can be combined to provide optimum continuous earth coverage.

Most of the LEO and MEO orbits are polar. A MEO system however exists that borrows the name of its orbit, ICO, Inclined Circular Orbit. This can cause some confusion, since an alternative, although less accurate acronym for MEO, more frequent in European literature, is Intermediate Circular Orbit (i.e., ICO). Here, the most usual MEO acronym is used, reserving ICO for the proposed system with that name.

A general problem with Class 2, low-perigee, inclined orbits is the rotation of the orbital plan due to the earth's oblateness. This rotation would constantly move the coverage area. The larger the eccentricity, the smaller the perigee height, the shorter the period, and the greater the instability of the orbit. The only way to stabilize such an orbit is to use a particular value of inclination, namely 63.435°. One such stable inclined elliptical geosynchronous orbit is the so called *Molnyia* orbit. It has a period of half a sidereal day, a perigee height of 500 km, and an apogee height of 39,800 km. The apogee of this orbit always remains at a constant geographic latitude. Another orbit from this class with lower eccentricity is called the Tundra orbit. Its period is a full sidereal day. In both cases, the most useful part of the orbit is the region of the apogee (active phase); there the satellite appears to move slowly, and stays close to the observer's zenith for a long time.

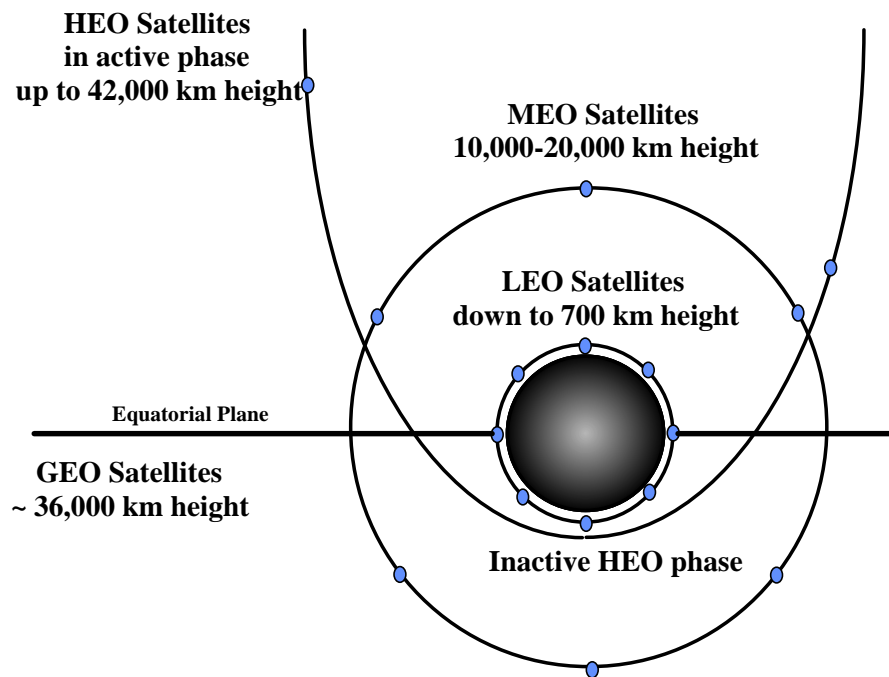
---

<sup>6</sup> Inclination is referred to the equatorial plane. Polar orbits are inclined 90°.

In a geo-synchronous orbit (classes 1 and 2), a satellite completes an integral number of orbits per day.

<sup>8</sup> Geostationary orbits are geosynchronous orbits with a period of one day, the result is the relative stationarity of the satellite in reference to a point on the earth's surface.

A final observation is that the higher the satellite orbit, the greater its coverage, the lower its relative velocity and thus the Doppler shift, and the longer it stays above the horizon. The advantages are balanced by the fact that the propagation delay worsens with increased satellite altitude.



**Figure 7.5-13 Satellite Orbits**

#### 7.5.1.1.3.3 Communication Subsystem Characterization

The communication subsystem on a communications satellite consists of a number of repeaters which amplify the signal received from the uplink, and condition them in preparation for transmission on the downlink. Each repeater belongs to one of the following types:

- Transparent, Non-Regenerative, or Bent-Pipe Repeater, referred to as Transponder -- they perform solely a frequency conversion from the uplink band to the downlink band (the conversion may be done in two or more steps);
- On-board Processing Repeater -- they first perform signal regeneration, and then they act as “switchboards in the sky”, circuit-switching between antennas, and possibly multiplexing the reconstructed received signal for transmission at a higher bit rate.

The advantage of the “transparent” repeater is that their transponders impose minimal constraints on the characteristics of the communication signals. For example, they are “transparent” to different modulation types, whether analog or digital. They therefore offer maximum flexibility for designers of large communication networks. However, there is the risk of increasing the bit error rate (BER) at each conversion.

#### 7.5.1.1.3.4 Proposed Satellite Systems

The panoply of proposed satellite systems ranges from the ambitious, 840-satellite LEO constellation advanced by Teledesic, to the “down-to-earth”, three-satellite GEO constellation of Skycell, including also the very vague, 12 satellites in the Ka-band for voice, data, and multimedia services proposal from

AT&T, an even more ambiguous 9-satellite proposal from Lockheed Martin for the same Ka-band, and the Picosats concept, which calls for literally a myriad of pico-satellites which one can virtually own (if one wishes to invest \$50,000). The three latter systems are not analyzed herein for lack of concrete information.

Most of the mobile satellite systems are low earth orbit (LEO) systems, which are much closer to the earth than the geostationary (GEO) satellites normally used for telecommunications thereby significantly reducing communications delay. Because of their proximity to earth, LEO systems accommodate low-powered and compact user terminals.

#### 7.5.1.1.3.4.1 Little LEO's

The little LEO's are low earth orbit satellite systems that operate in the VHF range and carry only data communications. They are not very complicated, and are therefore easier and less expensive to build and operate than a system that also carries voice communications, for example.

##### 7.5.1.1.3.4.1.1 ORBCOMM

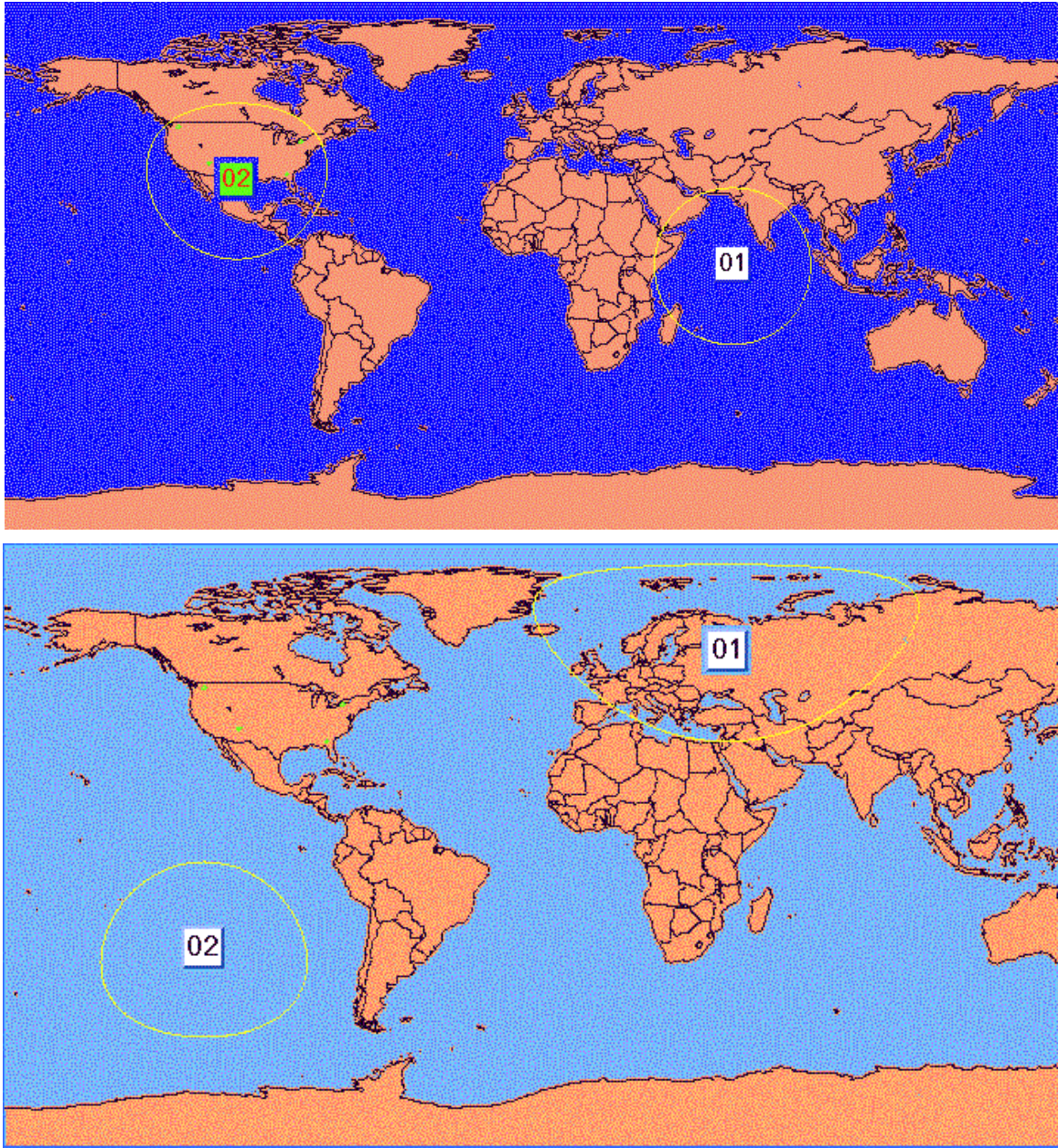
ORBCOMM plans a system of 20 LEO satellites costing less than \$150 million. The ORBCOMM system is a good example of a bent-pipe architecture, which all but two of the mobile satellite systems utilize. The mobile user sends a message to a satellite and that satellite routes the message to one of four gateway earth stations located in the four corners of the continental United States.

The four earth stations will be connected to the network hub in Virginia and will route the message there to determine where it should be sent. The messages can be sent from Virginia through the public and private e-mail networks, a leased line to a specific location, or back through the system to another mobile user.<sup>9</sup>

ORBCOMM began operation in February 1, 1996 after successfully launching in April 1995 the first two satellites of its intended 20/26/36 satellites constellation. (According to NASA, the two satellites had communication problems after launching, but are now operational. Coverage of the two satellites is shown in Figure 7.5-14.) ORBCOMM has become the world's first commercial satellite-based two-way messaging and positioning system. However, from **Error! Reference source not found.**, we can see that the first two satellites cannot offer more than sporadic coverage of the Continental U.S. This situation will obviously improve with the deployment of further satellites.

---

<sup>9</sup> It is not possible, in a bent-pipe architecture, to send a message from one satellite to another; the satellites basically link the user with the land-based network.



**Figure 7.5-14 Location of, and Coverage Provided by, the Two Already Deployed ORBCOMM Satellites at Two Instants in Time**

ORBCOMM has signed up 17 candidates to become international users. They plan to charge about \$1 per message (100 byte), plus a fixed monthly fee. The terminal will eventually cost between \$100 and \$400 dollars.

**7.5.1.1.3.4.1.2 STARSYS**

Starsys is a U.S. company that provides global positioning services. It plans to start initial service in 1996 with a data-only, two-way radio communications system with 24 satellites to connect remote users' portable terminals to a central ground station. Starsys claims it will be able to locate the terminal to

within 100 meters. The system is estimated to cost \$200 million. Subscriber terminal costs are estimated at \$75 to \$250 for the 3rd generation.

Like ORBCOMM, Starsys plans to offer emergency communication, stolen asset recovery, and hazardous materials tracking services.

#### 7.5.1.1.3.4.1.3 Comparative Analysis

Issues that need clarification include multiple access technique, dual-mode versus single mode user terminals (cellular and satellite), supported mobility, and most importantly, overall system cost. Table 7.5-6 provides the side-by-side comparison.

**Table 7.5-6 Little LEO's**

<b>SATELLITE SYSTEMS</b>	<b>ORBCOMM</b>	<b>STARSYS</b>	<b>VITASAT</b>
<b>PARTNERSHIP</b>	Orbital Sciences Corp., Teleglobe, TRW	North America Collection and Location by Satellite (NACLS), and ST System	Volunteers In Technical Assistance (VITA, VITACOMM)
<b>NUMBER OF SATELLITES</b>	20, 26, 36 depending on reference	24	2 satellites since 1984, 3rd added in 1995 (VITASAT-A, a.k.a. GEMSTAR-1)
<b>COVERAGE</b>	US now, Global future	Global	Global, designed for developing countries including South America, Africa
<b>SCHEDULED OPERATION</b>	Currently Operational in US; 1996 Canada and Mexico; 1997 Europe and Latin America	1996	End of 1995
<b>PERCENTAGE OF OBTAINED FINANCING</b>	"100%"	?	?
<b>FCC LICENSE</b>	late 1994	1992 Experimental License	?
<b>DATA RATE (kbps)</b>	2.4 uplink, 4.8 downlink	?	?
<b>HAND-HELD vs. PORTABLE USER TERMINALS</b>	Portable and Hand-held	?	Portable
<b>USER TERMINAL COST</b>	\$100 -\$400	?	\$3500
<b>DATA RATE COST (US Dollars per kilobyte)</b>	\$1.00 per 100 bytes	?	\$50/month for up to 100 kbytes
<b>SERVICES</b>	two-way messaging, RDSS	one-way data, two-way messaging	two-way messaging; store and forward with typically 90 minute and as much as 12 hour message delay.
<b>TARGETED APPLICATIONS</b>	emergency comm. 2 way-mail, remote resource monitoring	emergency comm. stolen asset recovery, hazardous material tracking	Store-and-forward data

#### 7.5.1.1.3.4.2 Big LEO Systems

The big LEO systems are distinguished from the little LEO's by their bandwidth. Big LEO's operate above 1 GHz and are able to carry voice as well as data. Most use more satellites for greater capacity and reliability. Because big LEO's are able to carry voice, many of the systems will be marketed and priced with voice service in mind, meaning that sending data might not be as cost effective as it would be using a little LEO system. Big LEO's are also much more expensive to build and operate.



#### *7.5.1.1.3.4.2.1 Constellation*

Formerly called Aries, the Constellation satellite system consists of 48 satellites, and plans to provide service for mobile phone users outside of cellular's coverage. Constellation Communications Inc. also expects their service to be used in rural areas of developing nations, where installing telephone switches and wires may not be cost-effective. The equatorial plane of the system, dubbed ECCO, will be deployed as a joint venture with Embratel, Brazil's government telecommunications holding company.

#### *7.5.1.1.3.4.2.2 GlobalStar*

GlobalStar plans to commence initial commercial operation via a 24-satellite LEO constellation in 1998 (full 48-satellites coverage is anticipated for 1999). The constellation will be deployed in a 1,410 km orbit (resulting in no perceptible voice delay), and provides multiple satellite coverage (2-4 satellites will usually be visible at any time). The satellites are of the "bent pipe" type for simplicity and reliability, as well as cost reasons. GlobalStar employs CDMA spread spectrum access techniques to provide full global services.

GlobalStar intends to provide high quality telephony, data transmission, paging, fax, and position location to areas currently poorly or not at all served by existing wireline and cellular systems. The service, however, has to be authorized by the local telecommunications regulatory authorities. Users of GlobalStar should expect to make and receive calls using hand-held or vehicle-mounted terminals similar to today's cellular telephones. Because the system will be fully integrated with existing fixed and cellular networks, GlobalStar's dual-mode handset units will be able to switch from conventional cellular telephony to satellite telephony as required. Calls will be routed to customers through existing public and private telephone companies. GlobalStar handsets will be able to be used as mobile phones anywhere in the world using an individual subscriber number accessing either the local network or the satellites directly.

The GlobalStar system consists of the same number of satellites as Constellation, though its expected capacity is much larger. The added complexity is reflected in the anticipated cost of \$2 billion. \$1.4 billion has already been raised. Anticipated average call prices range from 35¢ to 53¢ per minute although this may seem optimistic. No data pricing information is available.

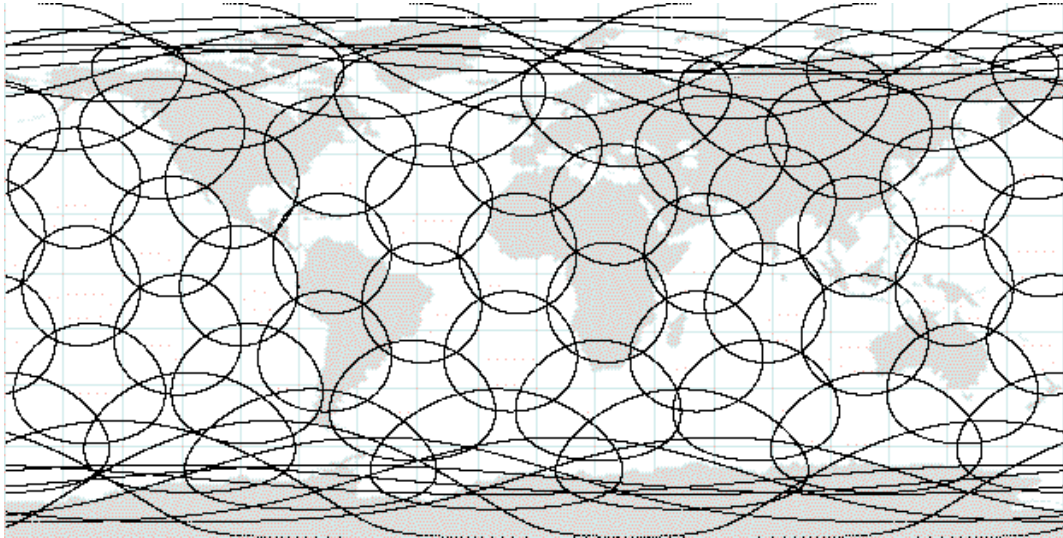
Leading an international coalition of companies teaming up to build the GlobalStar system are Loral and Qualcomm and Space Systems/Loral. Their strategic partners are Air Touch Communications, Italy's Alenia Spazio and Elsag Baley (Finmeccanica), France's Alcatel and France Telecom, Korea's Dacom Corporation and the Hyundai Electronics Group, UK's Vodafone Group, and Germany's DASA (formerly Deutsche Aerospace AG).

#### *7.5.1.1.3.4.2.3 Iridium*

Iridium plans to be operational in 1998 with a 66-satellite system for worldwide mobile communications services to provide direct-via-satellite global voice, data, paging, and radio-determination services to pocket terminals anywhere in the world. Total system cost is estimated at \$3.4 billion.

Iridium will use TDMA whereas others plan to use CDMA. Five experimental models have approval for 1996 to demonstrate system feasibility. The consortium includes Motorola, Sprint, Lockheed/Raytheon, Japan's Nippon Iridium, Saudi Arabia's Mawarid Corp., Canada's BCE Mobile, Venezuela's Muidiri Investments, Italy's STET, Korea's Hyundai Electronics, Thailand's United Communications, Russia's Krunichev Enterprises, China's China Great Wall Industry, Taiwan's Pacific Electric Wire & Cable Co., India's Infrastructure Leasing & Finance Services, Germany's Deutsche Aerospace, and UK's Vodafone Group.

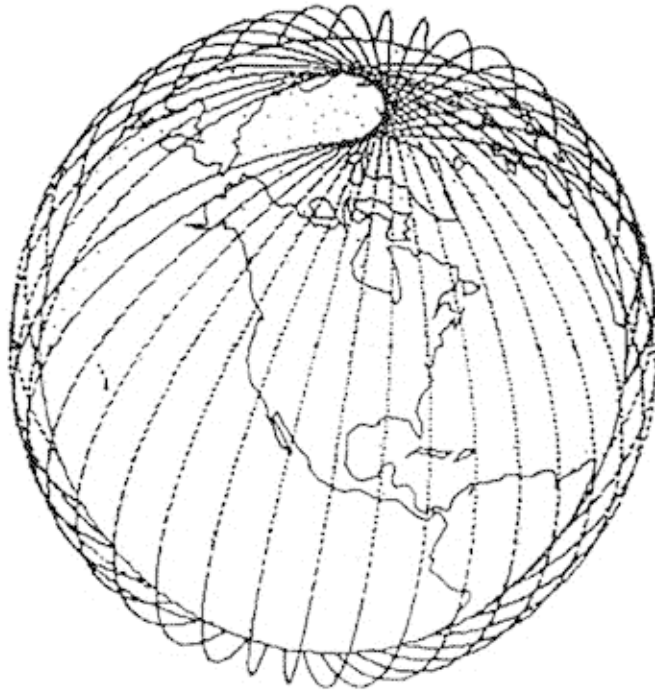
Motorola's ambitious Iridium system incorporates inter-satellite links (see Figure 7.5-15), which greatly raises the complexity of their satellites. A system with inter-satellite links, though, will be more robust and offer greater world-wide coverage than a comparable one without them. In an area without ground stations, a bent-pipe satellite would be unable to open a voice connection and could only store or send previously stored messages to a mobile unit.



**Figure 7.5-15 Iridium System Footprint at a Given Point in Time**

#### *7.5.1.1.3.4.2.4 Teledesic*

By far the most ambitious LEO is Teledesic, an 840 “refrigerator-sized” satellites system backed by Bill Gates and Craig McCaw. The satellite trajectories to cover the globe are shown in Figure 7.5-16. Teledesic plans to operate in the 20/30 GHz range. Teledesic Corp. anticipates a basic channel rate of 16 Kbps, and channels may be combined by fixed ground units up to a maximum of 50 Mbps. It also will incorporate inter-satellite links. Teledesic does not plan to be operational until 2001 and will cost at least \$9 billion. Teledesic is *not* intended for mobile terminals.



**Figure 7.5-16 Path Described by a Teledesic Satellite**

*7.5.1.1.3.4.2.5 Comparative Analysis*

Key issues in the success of any of these systems will be voice and data service costs, user terminal costs, system security, and supported mobility. All this, however, assumes the systems get deployed, which is not guaranteed given the huge costs involved. Obtaining the operating licences needed to provide service globally is certainly not an easy task and is another area of risk. Table 7.5-7 provides a comparative summary for the LEO satellite systems.

**Table 7.5-7 Comparative Analysis of Big LEO's**

<b>SATELLITE SYSTEMS</b>	<b>CONSTELLATION (formerly ARIES)</b>	<b>GLOBALSTAR</b>	<b>IRIDIUM</b>	<b>TELEDESIC</b>
<b>LEADERSHIP</b>	Constellation Communication	Loral, Qualcomm	Motorola	Bill Gates of Microsoft, and Craig McCaw founder of McCaw Cellular Communications, Inc. and chairman of Teledesic
<b>NUMBER OF SATELLITES</b>	48	48 plus 8 spare	66 plus 6 spare	840 plus up to 84 spare
<b>COVERAGE</b>	Global	within +/- 70 degrees latitude	Global	Global, except for 2 degree hole at poles; 95% of earth's surface
<b>SCHEDULED OPERATION</b>	1998	1998	1998	2001
<b>PERCENTAGE OF OBTAINED FINANCING</b>	~15%	~70%	~100%	?
<b>FCC LICENSE</b>	?	Jan. 1995	?	?
<b>MULTIPLE ACCESS TECHNIQUE</b>	CDMA	CDMA	FDMA/TDMA/TDD	TDMA, SDMA, FDMA, Advanced TDMA
<b>VOICE CIRCUITS PER SATELLITE</b>	?	2000-3000	1100 (power limited)	100,000 (16 kbps channels)
<b>VOICE RATE (kbps)</b>	4.8	adaptive 2.4/4.8/9.6	2.4/4.8	16
<b>DATA RATE(kbps)</b>	2.4	7.2 sustained throughput	2.4	16 to 2048
<b>MOBILITY</b>	?	?	?	Fixed
<b>DUAL-MODE vs. SINGLE MODE USER TERMINALS (land and satellite)</b>	?	DUAL	DUAL	SINGLE
<b>HAND-HELD vs. PORTABLE USER TERMINALS</b>	Hand-held	Hand-held	Hand-held	Portable
<b>SYSTEM SECURITY</b>	?	?	?	encryption
<b>SYSTEM COST (Million US Dollars)</b>	\$1,700	\$2,000	\$3,700	\$9,000
<b>USER TERMINAL COST</b>	?	~\$750/terminal; \$1000-\$1200 for telephone	\$2500-\$3000	?
<b>VOICE SERVICE COST (US Dollars per minute)</b>	?	\$0.35-\$0.55	\$3.00	?
<b>DATA SERVICE COST (US Dollars per kilobyte)</b>	?	?	?	?
<b>SERVICES</b>	voice, data, fax	Voice, data, fax, paging, short message service, RDSS	Voice, data, fax, paging, messaging, RDSS	Voice, data, fax, paging, video
<b>TARGETED APPLICATIONS</b>	extension of the cellular network	worldwide communication	worldwide communication	ISDN to rural businesses and remote terminals (fixed)

Note: The information in this table is based on inputs provided by the marketing organizations for the vendors and have not been validated by the Architecture team.

#### 7.5.1.1.3.4.3 Other Mobile Satellite Systems

A few companies believe LEO is not the best configuration for a mobile satellite system. Hence, they are proposing highly elliptical orbit (HEO), Medium Earth Orbit (MEO), and Geostationary (GEO) systems.

##### 7.5.1.1.3.4.3.1 *Ellipso*

Ellipso plans to be operational in 1997 and to provide combined position determination and mobile voice services using up to 24 satellites. Six experimental spacecraft have approval from the FCC. They will use FDMA and CDMA techniques.

Ellipso's unique elliptical orbit will provide more coverage to areas with high traffic at a certain times of the day. For example, if the time of maximum duration visibility over New York were selected to be mid-day, maximum duration visibility for Chicago, Denver, and Los Angeles would also be mid-day. To complement the elliptical orbit, the Ellipso system has a second component, MEO, providing additional coverage of intermediate latitudes.

Ellipso also plans to become an extension to the cellular network, providing service where cellular is not available. Costs to users will be comparable to those of cellular. Contracts exist with countries including Canada, Mexico, Israel, and Australia.

##### 7.5.1.1.3.4.3.2 *Odyssey*

Odyssey is a MEO system. Its higher orbits allow it to cover the globe with only 12 satellites. The smaller number of satellites makes Odyssey slightly cheaper than the big LEO's, but its capacity will be smaller, and user terminals will probably be more complicated and more expensive. Ground control stations will serve as gateways to local networks for voice and data communications to hand-held terminals worldwide.

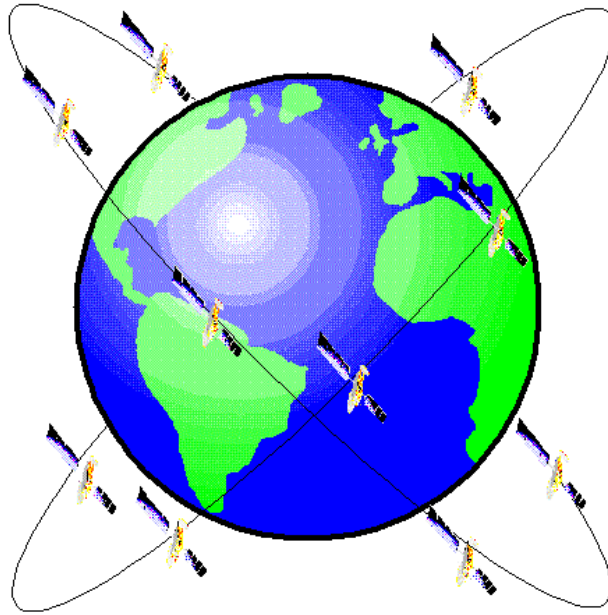
Odyssey's main partners are Teleglobe and TRW. Participants in the system design group include Harris Corporation, France's Thomson-CSF, Canada's Aerospace Ltd. and Northern Telecom, Germany's ANT Nachrichtentechnik GBH.

##### 7.5.1.1.3.4.3.3 *ICO Global Communications*

ICO Global communications, backed by 44 international investors, plans to have its 10-satellite MEO (or ICO), 10,400 km orbit system (see Figure 7.5-17) in service by the year 2000. When fully operational, the ICO system intends to provide a low-cost global satellite phone service, as well as data, fax, and paging, using hand-held pocket-sized terminals. It will be fully complementary with terrestrial cellular/PCS. ICO is already a member of the GSM MoU, but it will also support D-AMPS and other 2nd and 3rd generation digital cellular systems.

Two or more satellites will be usually visible to the users at relatively high angles of elevation to minimize blocking by terrain, buildings, and other obstacles. The satellites will relay calls between the user and a Satellite Access Node (SAN) within the satellite's view. SAN's are interconnected using terrestrial facilities to form a network, the ICO-Net, and are linked through gateways to the PSTN.

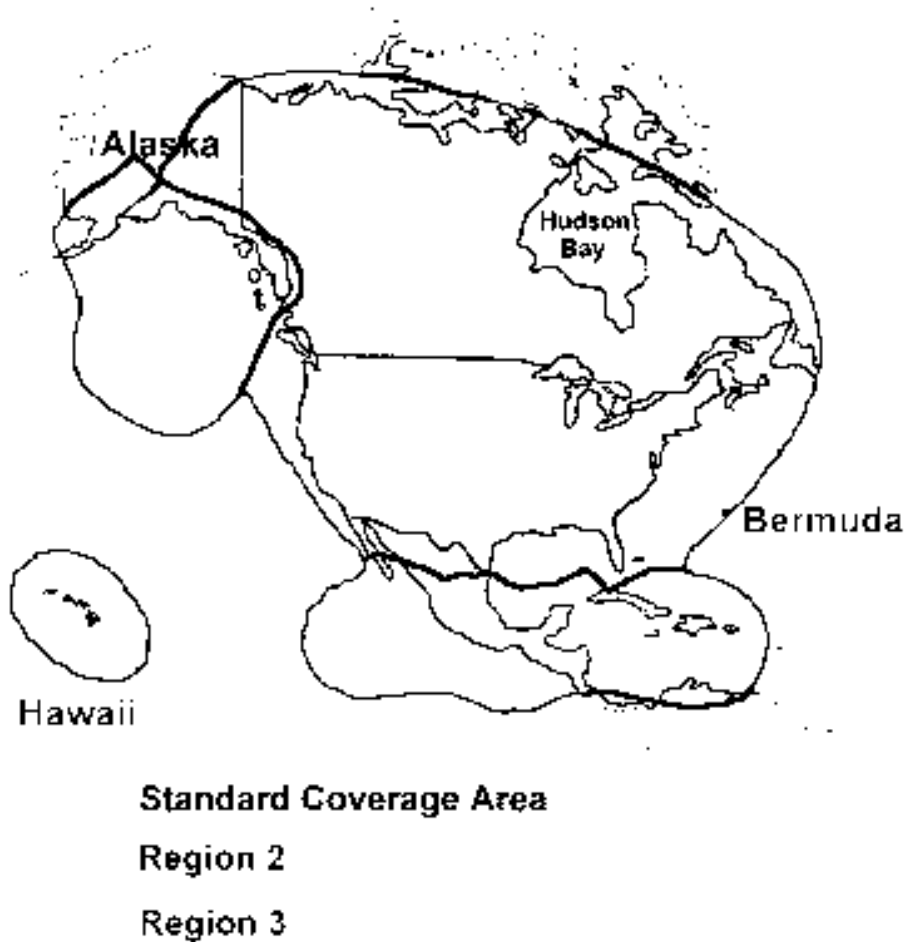
ICO began as Inmarsat P, or Project 21, later spinning into a separate commercial entity, since its scope expanded beyond coastal areas. The system cost is estimated at \$2.6 billion and \$1.5 billion have already been secured. Hughes is ICO's first strategic partner, and has invested an amount (\$94 million) equal to ICO's largest non-institutional investors (Inmarsat invested \$150 million, becoming the major investor).



**Figure 7.5-17 ICO's Satellite Orbits**

*7.5.1.1.3.4.3.4 Skycell*

The American Mobile Satellite Corp. (AMSC) plans to offer voice, data, and location service with its new Skycell system, a series of three GEO satellites. Figure 7.5-18 shows the planned coverage. Because of the much greater distance to the satellites compared to LEO, hand held terminals will not be offered. Vehicle mounted units are expected. Skycell has already obtained an FCC license.

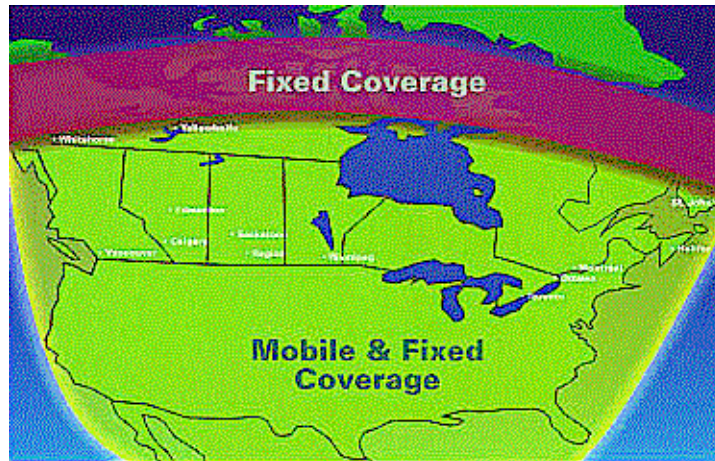


**Figure 7.5-18 SKYCELL Coverage**

*7.5.1.1.3.4.3.5 MSAT*

TMI and AMSC were the companies that initiated, funded, developed and launched the satellite that will be used to provide commercial mobile satellite service in North America. Commercial service is anticipated for early 1996. MSAT extends mobile and fixed telephone (6.4 kbps codec), fax, data (2.4 and 4.8 kbps), and dispatch radio communications to all of North America plus up to 400 km of coastal waters, the Caribbean, and Hawaii, as well as Mexico and Central America. The system is fully connected to the PSTN, and to public and private data networks.

Figure 7.5-19 shows the type of terminal supported. Mobile units use a small 7" dome antenna, and transportable units use a 30" flat antenna that can be easily set-up by the user. Call rates vary from \$1.55 to \$2.75 per minute, depending on the plan, and on the service modality, fixed or mobile.



**Figure 7.5-19 MSAT North American Coverage**

*7.5.1.1.3.4.3.6 Comparative Analysis*

Issues of mobility, service, and terminal cost will be determinant for the success of MEO/HEO systems. Tables 7.5-8 and 7.5-9 provide comparison summaries for the MEO/HEO and GEO satellite systems respectively.



**Table 7.5-8 Comparative Analysis of MEO and HEO Satellite Systems**

<b>SATELLITE SYSTEMS</b>	<b>ELLIPSO</b>	<b>ICO (formerly Inmarsat-P)</b>	<b>ODYSSEY</b>
<b>PARTNERSHIP</b>	Ellipso	Inmarsat, Multiple Government Agencies, and Hughes	Teleglobe, TRW
<b>ORBIT CLASS</b>	MEO and HEO	MEO (Intermediate Circular Orbits, ICO)	MEO
<b>NUMBER OF SATELLITES</b>	MEO is 6; HEO is 10	10 plus 3 spare	12 plus 3 spare
<b>COVERAGE</b>	North of 50° South	Global	major land masses
<b>SCHEDULED OPERATION</b>	1998	2000	2000
<b>SYSTEM COST (Million US Dollars)</b>	\$750	\$2,600	\$1,800
<b>PERCENTAGE OF OBTAINED FINANCING</b>	?	59%	?
<b>FCC LICENSE</b>	?	Aparently available	?
<b>MULTIPLE ACCESS TECHNIQUE</b>	CDMA	TDMA	CDMA
<b>VOICE CIRCUITS PER SATELLITE</b>	?	4500	2300
<b>VOICE RATE (kbps)</b>	4.15	4.8	4.8
<b>DATA RATE (kbps)</b>	0.3 to 9.6	2.4	9.6
<b>MOBILITY</b>	?	?	?
<b>DUAL-MODE vs. SINGLE MODE USER TERMINALS (land and satellite)</b>	Dual	Dual	Dual
<b>DUAL-MODE vs. SINGLE MODE USER TERMINALS (land and satellite)</b>	DUAL	DUAL	DUAL
<b>HAND-HELD vs. PORTABLE USER TERMINALS</b>	Hand-held	Hand-held	Hand-held
<b>USER TERMINAL COST</b>	~\$1000 or \$300 add-on to digital cellular unit	"Several Hundred"	~\$300
<b>VOICE SERVICE COST (US Dollars per minute)</b>	\$0.50	\$1-\$2	\$0.7 5 ; \$24 monthly charge
<b>DATA SERVICE COST (US Dollars per kilobyte)</b>	?	?	?
<b>SERVICES</b>	Voice, data, fax, paging, messaging, RDSS	Voice, data, fax, paging	Voice, data, fax, paging, messaging, RDSS
<b>TARGETED APPLICATIONS</b>	extension of cellular network	global phone integrated with cellular services	extension of cellular network

Note: The information in this table is based on inputs provided by the marketing organizations for the vendors and have not been validated by the Architecture team.

**Table 7.5-9 Comparative Analysis of GEO Satellite Systems**

<b>SATELLITE SYSTEMS</b>	<b>INMARSAT (A,B,C,M)</b>	<b>MSAT</b>	<b>SKYCELL</b>
PARTNERSHIP	Multiple Government Agencies (International Maritime Satellite Organization, consortium of 76 countries)	Mobile Satellite Corp., Glentel, Inc., BCE, Spar Aerospace, Hughes, Mitsubishi, Westinghouse	American Mobile Satellite Corp. (Hughes, AT&T, MTel, Singapore Telecom)
NUMBER OF SATELLITES	Inmarsat phase 2: 4 satellites (since 1992); Inmarsat phase 3: 5 satellites (projected for 1996)	2	?
COVERAGE	Global	North America, Hawaii, Caribbean	North America
SCHEDULED OPERATION	Operational since 1993	1996	?
SYSTEM COST (Million US Dollars)	?	?	?
PERCENTAGE OF OBTAINED FINANCING	?	?	?
FCC LICENSE	WARC, WRC	?	1989
MULTIPLE ACCESS TECHNIQUE	?	TDMA/TDD	FDMA
VOICE RATE (kbps)	6.4 to 16 depending on system	?	?
DATA RATE (kbps)	0.6, 2.4, 9.6, 64 depending on system	2.4	1.2-4.8
MOBILITY	Fixed to Aeronautical	Fixed (Canada and Alaska); Mobile (Contiguous 48 States)	Full mobility (vehicles, ships, and airplanes)
DUAL-MODE vs. SINGLE MODE USER TERMINALS (land and satellite)	Dual (drivers for ARDIS, CDPD, GSM)	Dual	?
HAND-HELD vs. PORTABLE USER TERMINALS	Portable	Portable	Portable
USER TERMINAL COST	\$5000-\$35,000 depending on system	\$5000-\$6000	?
VOICE SERVICE COST (US Dollars per minute)	\$2.00-\$8.00 depending on system	\$2.50	Standard : \$25/month, \$1.49/minute  Business:\$175/month, 200 minutes free, \$0.85/minute voice, data, fax
DATA RATE COST (US Dollars per kilobyte)	\$1.00-\$1.50	?	similar to voice service costs
SERVICES	Voice, data, fax, e-mail, store-and-forward, alerting, position determination	Voice, data, fax, dispatch radio	Voice, data, fax, location determination
TARGETED APPLICATIONS	Worldwide communications	Mobile office, position determination, e-mail, monitoring, voice dispatching (2-way), broadcast and multicast messaging	Transportation, maritime, aeronautical, remote site industries

Note: The information in this table is based on inputs provided by the marketing organizations for the vendors and have not been validated by the Architecture team.

### *7.5.1.1.3.5 Operating Mobile Satellite Systems of Interest*

#### 7.5.1.1.3.5.1 OmniTRACS

In the late 80's, QUALCOMM developed a geostationary (GEO) two-way Ku-band (11 and 13 GHz) data/messaging service called OmniTRACS. The system is spread-spectrum based, and is aimed at providing position reporting and messaging services for the trucking community. By early 1992 QUALCOMM had over 25,000 in use on trucks across North America and were successfully marketing their services world-wide. Today OmniTRACS claims more than 135,000 terminals all over the world, including its European counterpart, EutelTRACS, a joint venture of QUALCOMM and Alcatel QUALCOMM (established in 1990, 34% owned by QUALCOMM). Systems are currently operational in Mexico, Brazil (where it is known as OmniSAT), Japan, Russia, and Malaysia.

The OmniTRACS system is a low-rate interactive data communication tool that links fleet dispatch centers to their vehicles. This system uses QUALCOMM dedicated satellite systems, as well as commercially available satellite systems (i.e., transponders) as needed, for providing the interactive data services. For example, QUALCOMM has signed an agreement with ORBCOMM giving it the right to resell ORBCOMM's communication services with the OmniTRACS expanded trailer tracking and cargo monitoring applications.

The messaging and positioning information is sent, via satellite links, through the OmniTRACS Network Management Center to the fleet dispatch center. The mobile communication units provide the computing capability to send and receive text messages to and from the vehicles. The mobile units are also available with QUALCOMM's Automatic Satellite Position Reporting (QASPR). QASPR uses satellite triangulation to provide vehicle position to within 1/4 of a mile. The system also supports direct input from Global Positioning System (GPS) receivers. The system uses a proprietary Ku-band directional antenna that is encased in an aerodynamic dome. An electronically driven motor directs the antenna toward the satellite at all times. A new C-band system has been introduced for those regions where Ku-band is not readily available (e.g., Malaysia). In this case, vehicle tracking is made possible only through the use of a GPS receiver.

The OmniTRACS mobile terminal can be used for monitoring vehicle's status. The sensor information is made available to the driver using the onboard terminal, and is transmitted to the dispatchers. Because of the cost of the satellite terminal, this system is only suitable for long-haul truck operations that need very wide area coverage that includes remote areas.

#### 7.5.1.1.3.5.2 INMARSAT Satellite Systems

Inmarsat (International Maritime Satellite Organization) was formed by a consortium of 28 founding countries upon adoption of the Inmarsat Convention in September 1976. The corresponding operating agreement came into force in July, 1979. Today 76 countries are Inmarsat signatories.

Although its charter was to "make provisions for the space segment necessary for improving distress and safety of life at sea, communications, efficiency and management of ships, maritime public correspondence services, and radio determination capabilities", its scope has extended beyond coastal regions, encompassing today land mobile applications.

Before discussing the types of Inmarsat services which are operational, two terms must first be defined: 1) Mobile Earth Station (MES), which can also be a ship or even a plane, and, 2) Coastal Earth Station (CES). The services offered by Inmarsat are:

1. Inmarsat A (1980): Analog FM system offering telephone, telex, fax or data circuits between an MES and a CES with data rates up to 56 kbps. The MES's are relatively complex, and expensive

(\$25,000 to \$50,000 each), usually they are only present in the larger ocean-going vessels. Recently, “suitcase” Inmarsat terminals were introduced particularly for land mobile applications.

2. Inmarsat B (1993): Digital replacement for Inmarsat A. It utilizes a 16 kbps voice codec.
3. Inmarsat C (1991): Based on a low cost MES, it was designed to provide a two-way data messaging service. The objective was to reduce, besides the cost, the size and weight of the terminals. The MES uses a small, omnidirectional, low gain antenna, to support a 600 bps data channel. The smallest available MES weighs 4 kg. The terminals cost \$5,000- \$8,000.
4. Aeronautical System (1991): Designed to provide a digital voice and data service between jet aircraft and Land Earth Stations (LES). It provides voice and data services up to 9.6 kbps using high gain, steerable antennas on the aircraft. The use of a small, omnidirectional antenna supports a low bit rate (600 bps) data service.
5. Inmarsat M (Global beam, 1992; Spot beam, 1995): Provides low cost digital voice, fax, and data services for maritime and land mobile applications. A 6.4 kbps digital codec is used for voice transmission, and data is only supported up to 2400 bps. Terminal cost ranges between \$10,000 and \$15,000. For transportable applications, “briefcase” terminals weighing around 10 kg were introduced, offering far greater mobility than the current Inmarsat A “suitcase” units.

Another Inmarsat phase, Inmarsat P, evolved to become a separate program, dubbed ICO Global Communications, analyzed elsewhere in this document.

#### 7.5.1.1.3.5.3 VSAT

VSAT networks are networks of satellite earth terminals with antenna diameters in the region of 1 meter, and therefore said to have very small aperture (VSA Terminals). Such earth stations make inefficient use of the satellite power and bandwidth, but are attractive because they are relatively cheap. VSAT networks are usually arranged in a star configuration in which each terminal communicates via satellite with a large central earth station known as a hub station. In some cases, the terminal instead of being fixed at the user premises, can be mobile (then it would be called MSAT). Not to create any confusion with the system of the same name, the term VSAT will be used here.

Apart from providing telex-type low-rate data services, the VSAT systems are now planned to support voice calls as well as higher-rate data communications. A typical VSAT system is today expected to be able to provide at least three types of services to its users:

1. Continuous Voice Service
2. Continuous Data Service
3. Packet Data Service

The continuous services for voice and data are similar in that both are circuit-switched services. The difference between voice and data “calls” is that a mobile terminal participating in a voice call will use a voice activity switch to provide TASI (Time Assigned Speech Interpolation). The voice activity switch turns off the transmitted signal from the earth terminal during idle periods of voice, thus reducing the power required by the satellite repeater (only active voice sources will be broadcast).

The packet data service is expected to carry low-rate, low-volume data for applications like messaging, paging, or telex-type services.

Systems required to carry both data and voice often have somewhat conflicting requirements. Data can be sent with random and possibly large delays, but must be sent error-free. Systems carrying data must have built-in automatic repeat request (ARQ) techniques for the recovery through retransmission of packets in

error. In addition, buffering and sequencing may also be required to ensure that a receiver can properly reconstruct the transmitted data stream. On the other hand, because of its inherent redundancy, voice traffic can tolerate some errors without a significant loss in quality, but delay requirements are more stringent.

In order to be economically viable, satellite communication systems should make efficient use of the satellite's limited resources of bandwidth and power. This is especially important in VSAT systems where a large number of essentially uncoordinated and statistically bursty users are expected to share these resources in an efficient manner. The appropriate Multiple Access technique has to be selected.

Numerous multiple access algorithms are discussed in the literature. They can be divided into three basic types:

1. Fixed Assignment
2. Random Access
3. Controlled Access

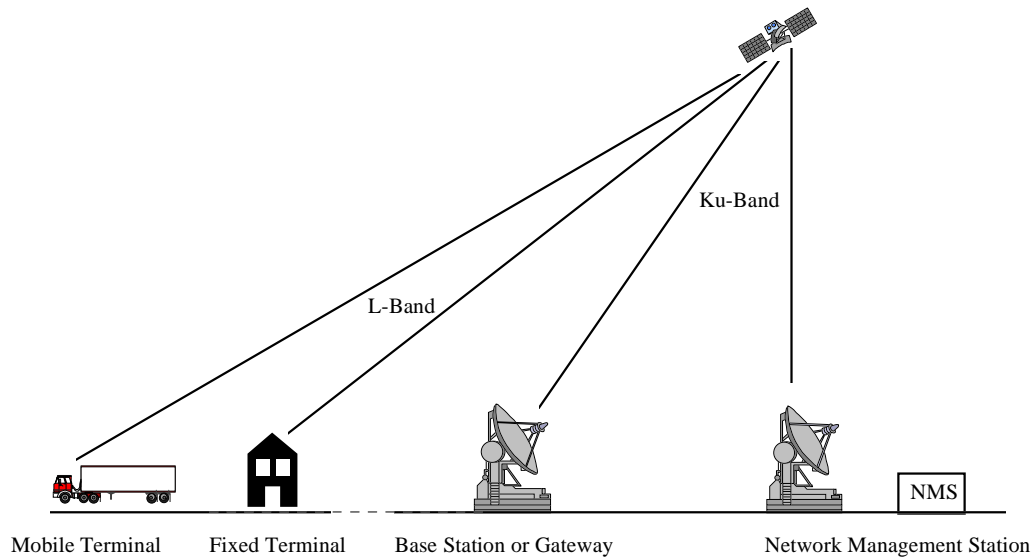
Fixed assignment schemes, such as those using FDMA, TDMA, or CDMA, permanently assign a "channel" to each (active) user. Such schemes are best suited to links carrying large quantities of steady traffic. For a VSAT system with a large population of bursty traffic sources, such a permanent assignment would be extremely inefficient.

Random Access techniques like pure or slotted ALOHA, would be better suited for the bursty traffic, despite the fact that they have to be operated at low efficiencies in order to avoid problems of instability.

For a system where the information generated by an active user tends to be long (voice calls and long data transfers), Controlled Access may be a better alternative. In such schemes, a fraction of the system's resources (bandwidth or time) is set aside to carry requests for resource assignment. For voice traffic, a demand assignment multiple access (DAMA) scheme is often preferred in which a circuit-switched channel is assigned to the user only for the period of the call for which it is needed.

From the above, and given the mix of traffic expected over such systems, a combination of the Random Access and Controlled access is warranted. DAMA schemes with Random Access are preferred. In these, short messages are transmitted directly on randomly chosen slots reserved for that purpose, instead of going through the reservation process. Using these advanced multiple access techniques, the VSAT system ends up performing efficiently and to everyone's satisfaction.

Figure 7.5-20 below presents the overall architecture of a typical VSAT satellite network. Apart from the mobile or fixed terminal, such systems rely upon one or more Network Management Stations (NMS), and other Base Stations or Gateway Stations. The NMS is responsible for the management of the overall system and provides appropriate control and signaling information to the other stations in the network. The Gateways are intended to be the primary interfaces to the PSTN. Direct communication between mobile/fixed terminals is not supported (in fact it is physically impossible due to the L/Ku-band mode of operation). If required, such communication will have to be carried out through an appropriate base station.



**Figure 7.5-20 VSAT Network Configuration**

#### 7.5.1.1.3.5.4 Positioning Satellites

Many of the ITS applications depend on, or can profit from, accurate knowledge of the user's whereabouts. Ignoring for the moment privacy concerns, it is important to discuss here available position determination systems. Briefly, the most commonly used satellite-based systems are discussed, GPS and Russia's GLONASS, as well as Differential GPS (DGPS), a hybrid satellite-terrestrial service the Coast Guard is developing for public use in coastal areas and in the Great Lakes.

Please note that there are quite a few terrestrial-based positioning systems. A few companies are already building equipment to provide DGPS using various correction signals. Most of these developments, however, are still cloaked in mystery, given that the techniques are proprietary, with patents pending, and most of the time still at the prototype stage. Thus, these proposals will not therefore be discussed, only their underlying principles.

##### 7.5.1.1.3.5.4.1 Satellite Navigation

The idea behind satellite navigation is both simple and ancient. The satellites, under control of precise and stable frequency references, transmit timing signals and data on their positions to the earth. A receiver measures the transit time of the signal, and deciphers the data. If the receiver clock were synchronized with the satellite clocks, measurements for range to three different satellites at known locations would allow a user to compute a 3-D position. The process is called *multilateration*. Since the receiver clock is not synchronized with that of the satellites, the transit time measurement has a common, unknown bias reflecting this difference. The biased range measurements are called *pseudoranges*. The measurement of transit time from a fourth satellite is then needed to solve the problem. Given four measurements, four unknowns can be solved, (x, y, z), and the receiver clock bias.

Having four satellites in view is only a necessary condition to compute a 3-D position estimate. The quality of that estimate depends upon two factors: 1) the spatial distribution of the satellites in view relative to the user, and 2) the quality of the pseudorange measurements. The first factor is referred to as *satellite geometry* and is characterized by a parameter called *dilution of precision (DOP)*. Basically, the more spread out the satellites, the lower the DOP, and the better the position estimate. The quality of the

pseudorange measurements is characterized by their rms error. Several sources of error affect the range measurements: errors in the predicted ephemeris of the satellites, instabilities in the satellite and receiver clocks, un-modeled ionospheric and tropospheric propagation delays, multipath, and receiver noise. The collective effect of these errors is referred to as *user range error* (URE). The rms of the position error is expressed simply as  $\sigma_{\text{Position Error}} = \text{DOP} * \sigma_{\text{URE}}$ .

For a satellite navigation system to be usable globally, all users must have in view at least four satellites with a good geometry, and the receiver URE must be such that the resulting position estimate meets the user's requirements.

#### 7.5.1.1.3.5.4.2 GPS

The planning of GPS began in the early seventies, and the first satellite was launched in 1978. The system is owned and operated by the DOD, but offers partial capabilities to the public.

GPS is a MEO system, at 26,560 km, consisting of 21 satellites, with 3 operational spares in 6 orbital planes (see Figure 7.5-21), and is fully operational. The system transmits at two frequencies in the L-band (L1, 1575.42 MHz; L2, 1227.6 MHz) using CDMA. Only the coarse acquisition (CA) code transmitted on L1 is available for civil use. In accordance with the current policy of the U.S. DoD, the signal available from GPS is actually a purposefully degraded version of the CA code. The signal degradation is achieved by dithering the satellite clock frequency, and by providing only a coarse description of the satellite ephemeris. This policy, known as *selective availability*, effectively raises the value of the URE by a factor of four or more ( $\sigma_{\text{URE}}$  is in the range 25 to 40 m when measured with selective availability, versus approximately 7 m without), and remains a source of controversy among the civil users. The Claimed Precision for civilian use at present is 100m Horizontal, 140m Vertical.

The U.S. has pledged to maintain the GPS Standard Positioning Service, when operational, for a period of ten years without any direct user fees. It has also been announced recently that selective availability (SA) will be discarded to permit higher accuracy civilian use at some time between the years 2000 and 2005.

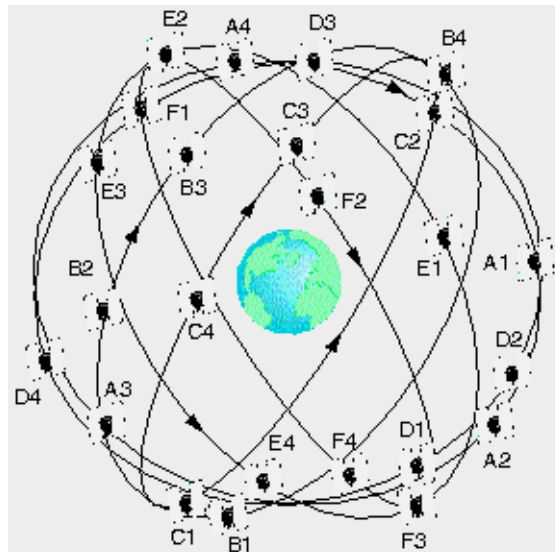
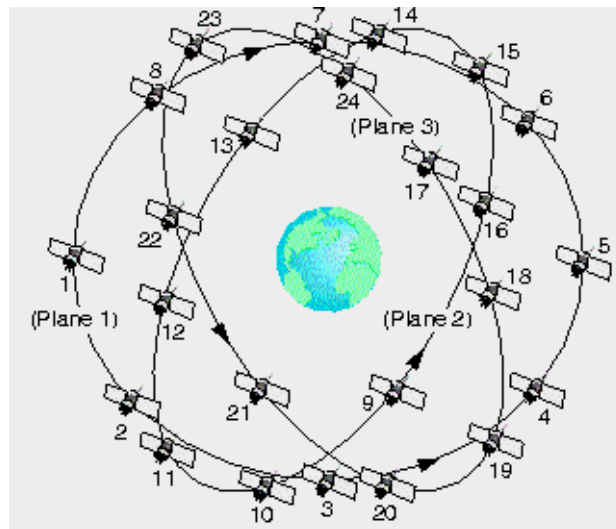


Figure 7.5-21 GPS Constellation

#### 7.5.1.1.3.5.4.3 GLONASS

Russia's GLONASS consists of a series of 24 MEO satellites in 3 orbital planes (see Figure 7.5-22) at 25,510 km providing navigational and accurate global positioning services (claimed precision: Horizontal = 100m; Vertical = 150m). The first GLONASS was launched in December 1980. The constellation remains sparsely populated (twelve active satellites on average for the past few years), and political and economic difficulties in Russia continue to be a source of uncertainty about its future.

GLONASS uses FDMA in the 1602 - 1615.5 MHz band. The service interferes with the radio astronomy band (1610.6-1613.8 MHz), and with the recently allocated mobile satellite service at 1610-1626.5 MHz. An L1 and L2 organization, with CA code for civilian use was adopted - similar to GPS. Although GLONASS officially disavowed a selective availability-like feature ( $\sigma_{\text{URE}} = 10 \text{ m}$ ), its positioning specifications are almost identical to those of GPS.



**Figure 7.5-22 GLONASS Constellation**

#### 7.5.1.1.3.5.4.4 Differential GPS

Differential GPS (DGPS) is the regular GPS with an additional correction (differential) signal added. This correction improves the accuracy of the GPS and can be broadcast over any authorized communication channel. DGPS receivers collect navigational information signals from all satellites in view, plus differential corrections from a DGPS station in the area. (Many DGPS receivers consist of two units: a GPS receiver, with a data port for DGPS corrections directly connected to a radio receiver.)

The Coast Guard is developing a DGPS service for public use in harbor and harbor approach areas, as well as in the Great Lakes, most of Alaska, Hawaii, and Puerto Rico. DGPS uses pseudorange corrections broadcast over the existing network of marine radio beacons. The Coast Guard plans to complete the system and declare it operational in 1996.

#### 7.5.1.1.3.6 Assessment for ITS

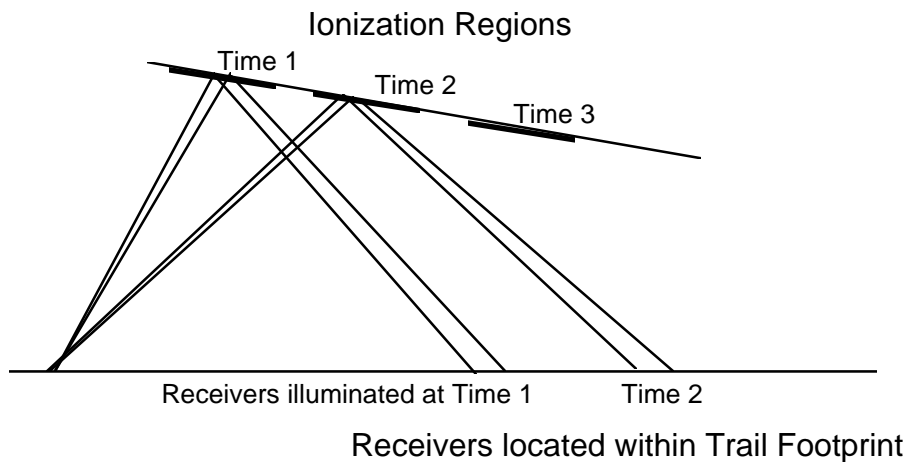
Summarizing now the technology assessment of satellite systems, it can be safely stated that the proposed and already deployed systems guarantee a wealth of choices for the provision of those ITS services that can not be provided by cheaper, more effective means, like two-way cellular. The user must moderate



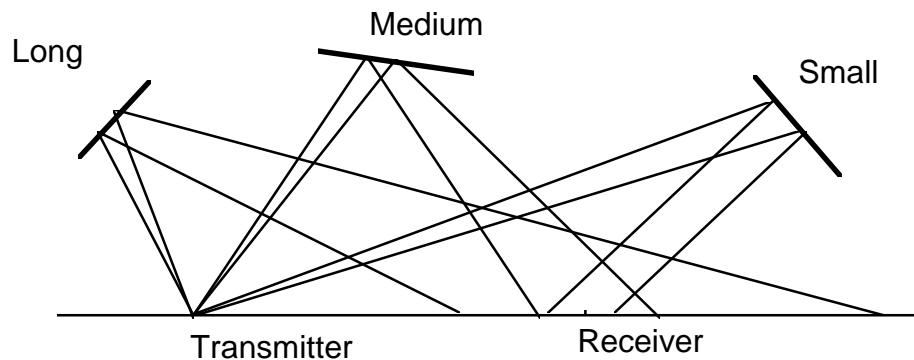
any optimistic expectations about service availability, given the huge investments required by most of the proposed systems in the face of market uncertainties, as well as their complexity and deployment risk.

#### 7.5.1.1.4 Meteor Burst Communications

The meteor burst (or meteor scatter) channel, known as the “poor man’s satellite channel”, relies on the ionized trails of meteors as reflectors to achieve long range packet data communications. It was found that useful ionized meteor trails occur at an altitude of about 80-120 km above the earth’s surface. Trails with useful electron densities for reflecting radio signals in the range of 40 to 50 MHz were found to be plentiful enough to provide communications over a range of roughly 2000 km. The minimum range limitation was found to be 400 km, as determined by the scattering geometry and electron density. The intermittent nature of the channel has to do with the random distribution of the meteors of interest which shows a strong diurnal variation (peaking at 6:00 local time, and with a distinct minimum at 18:00), and follows the Poisson law. Ionized trails were found to have a lifetime of only a few tenths of a second, creating the need for rapid exchange of information (thus the term “burst communications”). Due to the unique characteristics of the propagation mechanism (see Figures 7.5-23 and 7.5-24), Meteor Burst Communications relies on an inherent spatial multiplexing to reduce the contention in a network with potentially more than ten thousand units.



**Figure 7.5-23 Motion of Ground Illumination Region due to Trail Formation and Decay**



**Figure 7.5-24 Effect of Trail Location on Size of Footprint**

A system with the characteristics described above seems appropriate for communicating with remote, usually rural, sparsely populated areas, when there is no need for immediate, urgent communications. The coverage of conventional UHF cellular systems is too small for cost effective seamless coverage in very rural areas, especially away from major interstate highways. On the other hand, satellite service is very expensive to install and operate. Meteor Burst technology costs approximately 1/5 that of satellite systems, and the long term life cycle costs savings can not be underestimated (meteors are in essence free natural satellites, always available). Furthermore, since Meteor Burst operates in the low VHF band, the cost of the vehicle radio equipment is approximately half that of corresponding satellite equipment.

Examples of ITS services that a Meteor Burst system could potentially support are wide area Automatic Vehicle Location (AVL), and remote (long haul) Fleet Management. Surveys of potential users indicate that when out on the open road, position information every 10 to 15 minutes with short message capabilities is adequate for significant productivity enhancement. A Meteor Burst tracking system can fill the gap in the conventional cellular system where in remote areas the density of vehicles (and fixed users) cannot justify the base station infrastructure.

A Meteor Burst system could provide seamless coverage of the continental U.S. with as few as 100 base stations. However, noise levels in urban areas are too high for Meteor Burst usage. There, cellular coverage would have to be considered, pointing to the possibility of dual MB-cellular systems.

Several Meteor Burst systems have already been installed and proven effective:

- In the 1950's, Canada installed the JANET system between Toronto and Port Arthur for simple point to point teletype communications.
- Also in the 1950's, SRI, under contract from the U.S. Air Force, operated a test link from Palo Alto, CA to Bozeman, Montana, primarily for propagation research.
- The 60's saw the first operational military MB communication system deployed in Europe, called COMET, operated by the NATO SHAPE technical center, providing communication from The Hague, Netherlands, to southern France, again to transmit conventional teletype messages.
- In the late 70's, the Alaska SNOTEL (for SNOWpack TELemetry) system was installed to provide meteorological information from remote locations throughout Alaska.
- The Alaska National Guard recently installed a MB system that ties headquarters to remote locations throughout the state.
- A MB system has been installed between Sondstrom AB and Thole AB, Greenland.
- MB was selected for the Small Mobile ICBM (SICBM) program to provide primary communication under almost all conditions between mobile launch control centers and up to 1000 mobile launchers randomly dispersed over a wide area.
- Currently NORAD is testing a C<sup>3</sup> MB network that will connect the continental US, Alaska, and Canada.

As for commercial systems, a few experiments have been successful, namely one in the Portland, OR area where a long haul Fleet Management system has been deployed, taking advantage of the MB beyond line of sight communication capabilities.

As a conclusion, MB, although requiring a dedicated system, seems to be a cheap but still effective alternative to expensive satellite systems. In any circumstance, it cannot provide overall seamless coverage, thus requiring terrestrial cell-based coverage in urban and suburban areas in a dual MB-cellular system configuration.

#### 7.5.1.1.5 Broadcast Systems

In the area of ITS broadcasting there are presently as many as three different high data rate FM subcarrier systems in contention for national acceptance, while RBDS is already standardized (and available) for lower data rates.

Although we will focus primarily on FM subcarrier systems, other broadcast techniques will also be considered to determine their applicability to the ITS services. These technologies vary considerably from the simple, such as HAR, to the more advanced like DAB and transmission within the TV vertical blanking period, or to using a whole SAP sub-channel. We will address also the most promising of these other technologies.

The level of detail of the analysis will be determined by the anticipated ITS role. As applicable, the capacity of the above systems will be determined, as well as the information update rates allowed.

##### *7.5.1.1.5.1 Operational Environment*

The typical environments that broadcast systems will operate in include rural, urban, suburban and inter-urban areas. The received signal will experience propagation effects such as blockage and multipath, and the success of a broadcast system will depend on its effectiveness in defeating those effects.

The propagation anomalies are primarily dependent on the operational environment, such as the type of the natural and man made structures, e.g., hills and buildings. Furthermore, the climate, the vegetation, as well as the materials of the obstacles will also affect the propagation environment. The other variable that changes the propagation environment is the driving conditions. For example, when driving in the city there will be frequent blockage periods due to buildings, hence system performance will be a function of the driving speeds, and would be quite different for speeds that range from 0 to 70 mph.

Broadcast propagation environment, and the ability of the broadcast systems to mitigate its effects will be a key parameter in identifying the appropriate ITS services that can be supported using a particular communication technology. For example, there will be broadcast systems that will transmit messages at regular intervals, such as bus schedules and weather forecasts, and others that will transmit only at specific times (e.g. hourly news). Therefore, the loss of information due to blockage and multipath will be of a lesser significance for some services and of a greater significance for others.

By definition, broadcast systems are not suited for two-way communication. One can only envision their use in very specific applications of ITS (e.g., transmitting traffic status information both on the freeway system and on surface streets - a value added service that may be of interest to some broadcasters). This would require, however, coordination with (or by) the control centers, and the definition of strict receiver standards to minimize the cost associated with the display of information.

Moreover, as already stated, the most critical performance limitation of Subcarrier Authorization (SCA) arises from multipath, or fading in general. Unfortunately, in the ITS environment multipath is unavoidable if one wishes to employ simple, cheap antennas (e.g., whip or monopole antennas). Under mobile conditions, it is not possible, without incurring unacceptable receiver costs, to try to compensate for, or nullify, the multipath effects. Thus, the broadcast system must either be designed such that it accounts for the degradation caused by the multipath, or by explicitly taking into account that sometimes the receiver will not be able to properly receive the information.

A possible operational solution would be to continuously repeat the traffic status information, updating it on the run. If a vehicle is unable to receive traffic information for a while due to specific propagation conditions, it would rely on the last successfully received status report, which would be updated as soon as reliable reception resumes.

Another possible (possibly simultaneous) solution would be to provide alternative sources of information (other radio stations) providing the same traffic information, conveniently offset in time. This would necessitate a more complex (costly) receiver that would automatically switch from a “bad” to a “good” station.

#### *7.5.1.1.5.2 Evaluation Approach*

The goal of this technical evaluation is to analyze the capabilities of the existing and projected broadcast technologies in the context of the National ITS architecture. The analysis will utilize the requirements of the ITS services and communication links that are suited for one-way wireless dissemination, and their critical attributes, such as message sizes, information rates, frequency of use, etc. The results of the ITS broadcast data loading analysis of Section 5.2 will be applied in the evaluation.

The analysis will address the following issues and parameters:

1. Data rate for high and low data rate broadcast systems. Includes overhead for error correction and multipath mitigation (coding, interleaving, repeat broadcasting, etc.).
2. Message delivery delay.
3. Modulation techniques.
4. Coding and interleaving techniques for defeating channel errors.
5. Approach for mitigating mobile channel effects (e.g., multipath) These techniques include: (1) complex coding and interleaving, (2) combined modulation and coding, and (3) simple coding and interleaving with a repeated transmission algorithm.
6. The capacity of the broadcast system as a function of the message sizes and update frequency. The capacity and update frequency are inversely proportional, for a fixed information rate (i.e., as the requirement for the update frequency increases the effective capacity of the broadcast system decreases).
7. The data processing in the mobile units. It is an important consideration when evaluating the services that can be supported using broadcast techniques. This capability will allow broadcasting only the minimum amount of data (e.g., broadcasting compressed traffic information, instead of detailed information).
8. System coverage will be a function of the broadcast tower locations, and will also depend on the deployment strategy. The systems can use one or multiple frequencies for broadcasting. There are two options when using multiple stations (frequencies): (1) The stations can broadcast the same information with staggered repeat, which reduces message delivery delay at the cost of lost capacity; or (2) the stations can broadcast different information, therefore maximizing capacity.
9. System reliability. The effective broadcast data rate is reduced due to the reliability factor, as a result of system failures and propagation effects (e.g., blockage, multipath, etc.). A reliability factor of K% (e.g., 90% effective throughput) will be included in the analysis.
10. Addressing capabilities; the capability of addressing specific customers.
11. Interface issues: open versus proprietary interfaces.
12. Deployment cost.

In what follows the above issues will be addressed in some detail. Furthermore, the proposed and operating systems will be described and their specifications will be summarized. The analysis will

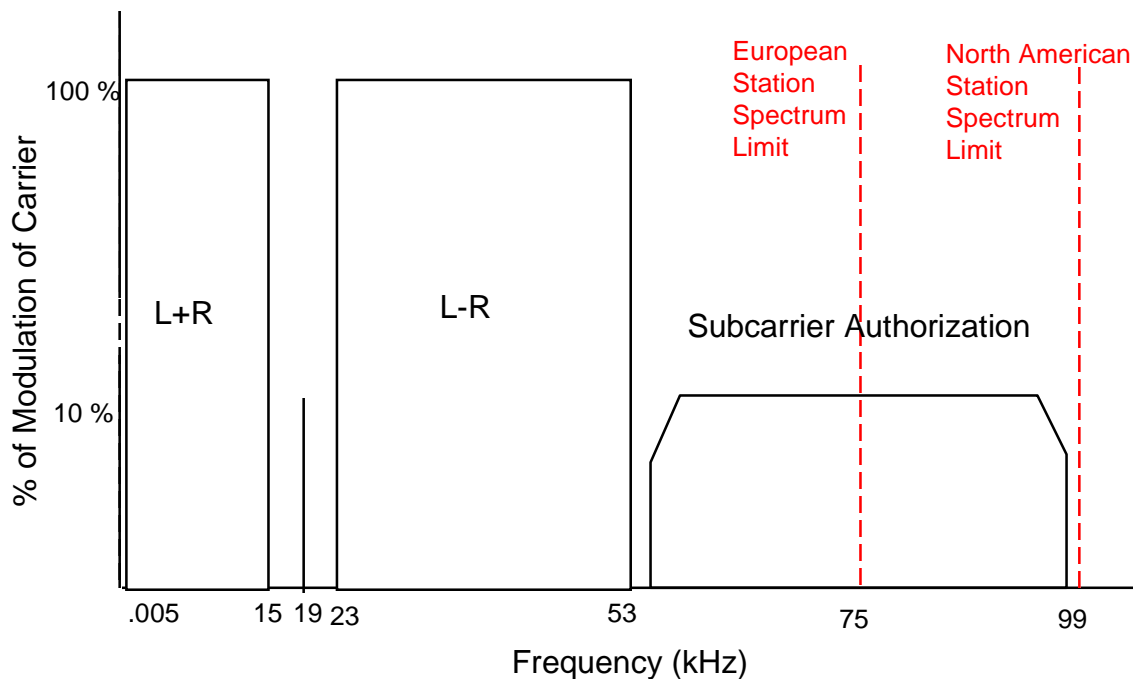
include field test results, when applicable. The field test results address issues related to deployment strategies, implementation, cost, candidate services, available hardware and terminals, and service provision.

### 7.5.1.1.5.3 FM Subcarrier

In Europe, the spectrum allocation for FM stations is 150 kHz, while in North America it is 200 kHz. The international CCIR standard allows a subcarrier frequency of 53 to 75 kHz, while the North American standard allows for 53 to 99 kHz.

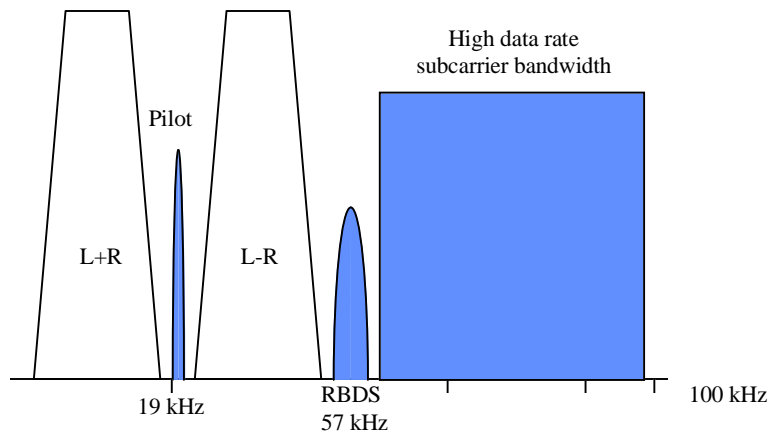
In recent years the FCC allowed for the opening of the FM baseband to 99 kHz, and relaxed the technical usage rules. This stirred up great interest in new services via SCA, e.g., teleprinter newscasting, computer data transmission, and paging. SCA allows for the use of the spectrum not occupied by the FM-stereo channel, provided certain conditions of non-interference with the audio channel are met. Deregulation has removed all restrictions on allowable modulations.

Figure 7.5-25 illustrates the FM baseband and subcarrier spectrum. Each FM station is allocated a 200 kHz bandwidth for transmitting the FM signal. In Figure 7.5-25, the baseband bandwidth between 53 and 100 kHz is not used for transmitting a stereo music signal, and can be used for broadcasting auxiliary programs and data. FM stations have the authority under their license to broadcast auxiliary programs and data without further permission from the FCC.



**Figure 7.5-25 FM Spectrum Allocation in North America and Europe**

The U.S. has adopted the international standard for transmitting low data rate using the FM subcarrier at the baseband frequency of 57 kHz (this is at three times the FM pilot of 19 kHz). This system is referred to as the Radio Broadcast Data System (RBDS). As a result, in order to insure co-existence of RBDS with high speed FM subcarrier systems, they are restricted to using the spectrum above 60 kHz (see Figure 7.5-26).



**Figure 7.5-26 FM Baseband Spectrum (Not to scale)**

The two most important problems inherent to FM subcarrier operation are *crossstalk* and the “birdies” effect. *Crossstalk* is the effect on the FM subcarrier channel of interference from the FM stereo channel, and it almost entirely determines the noise performance of the FM subcarrier. It is obviously determinant when operating a data FM subcarrier channel. The so called “birdies” which appear in the main FM stereo channel are interference caused by the FM subcarrier channel(s). They consist of high frequency audio whistles, typically 5–10 kHz, that are frequency modulated by the FM subcarrier material. This problem is solved in practice by the use of a PLL FM receiver for the case of a standard FM subcarrier channel side by side with the main FM stereo channel.

Any proposed system must prove non-interference with the main FM stereo channel, as well as other FM subcarrier channels.

#### 7.5.1.1.5.3.1 Proposed and Existing FM Subcarrier Systems

There are a number of broadcast systems that are operational or have been proposed. The main difference between these systems is in their modulation techniques and the approach for mitigating the multipath and other mobile propagation problems, such as multipath and blockage. These systems use two distinct techniques for combating the propagation impairments. In the first approach, complex coding and modulation formats are used, as in MITRE’s STIC and NHK’s DARC system. The second approach uses time and frequency diversity, for example multiple FM stations are used for frequently (e.g. twice every few minutes) broadcasting the same message. In the second approach the terminal captures the signal from the strongest broadcast station; SEIKO’s HSDS uses this scheme. These high data rate systems are described in greater detail in the subsections to follow.

We begin with RBDS, the U.S. version of the European RDS standard. R(B)DS provides low data rate service and is used, especially in Europe, to transmit traffic information without affecting the FM stereo signal.

##### 7.5.1.1.5.3.1.1 RBDS and RDS-TMC

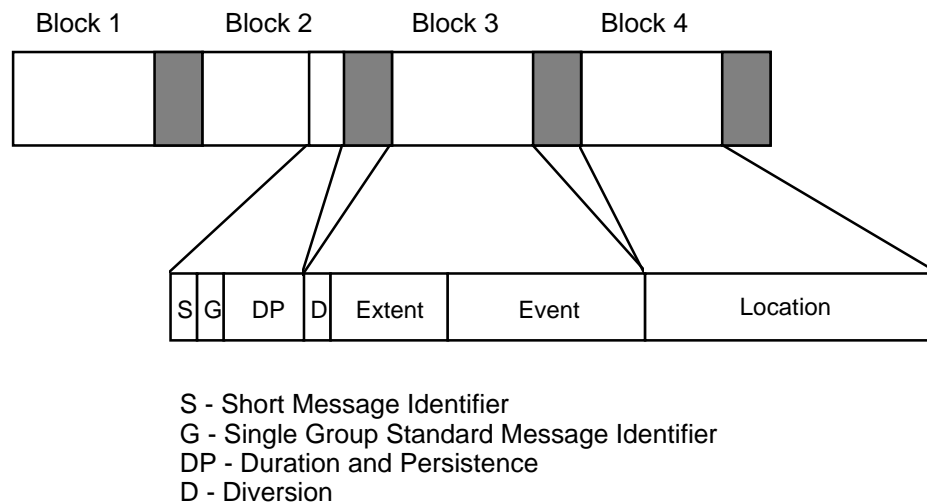
The Radio Data System (RDS) is an FM subcarrier standard first available in Europe and now gaining acceptance in the US under the acronym RBDS. RBDS uses bi-phase shift keying (BPSK) modulation format for transmitting at a data rate of 1187.2 bps, occupying the bandwidth from 53.5 to 59.4 kHz. The effective information rate for RBDS is about 300 bps, considering the overhead of coding and interleaving.

Broadcast traffic messages already provide a valuable information service to motorists throughout Europe. RDS enables traffic messages to be carried digitally and silently by a Traffic Message Channel (TMC), without necessarily interrupting/affecting the audio program.

The ALERT (Advice and Problem Location for European Road Traffic) C message coding protocol was a major product of DRIVE, the European R&D Road Transport Informatics (RTI, European version of ITS) program, and defines the standard for RDS-TMC throughout Europe. TMC messages are language-independent, and can be presented in the language of the user's choice. ALERT adopts a standard European list of traffic events (including weather) descriptions.

The ALERT protocol covers event-oriented driver information messages. Provision has been made for the subsequent definition of other applications, such as status-oriented route guidance and public transport information, as well as for alternative communications media such as AM broadcast data systems, GSM, and digital audio broadcast (DAB).

RDS-TMC information is conveyed in Type 8A RDS data groups (see Figure 7.5-27). Each standard message, as well as all system messages comprise only one group. (One Type 8A RDS data group carries 35 bits of information. Each block carries 16 bits of information, plus a check word and offset information.) Optional information can be added to standard messages up to a maximum length of five RDS data groups. Short messages have also been allowed using a half-group message sequence (in general, two distinct short messages, or the same repeated, are transmitted in one RDS data group). Standard RDS-TMC messages provide the following five basic items of explicit broadcast information: event description, location, extent, duration, and diversion advice.



**Figure 7.5-27 Single Group Standard RDS Message**

ALERT C uses location coding strategies which adopt hierarchical principles of structuring the location database in accordance with the European Broadcast Union (EBU) Broadcast for Motorists functional recommendations – the international, national, regional, and local levels are considered.

RDS-TMC messages are transmitted in a cycle whose duration is dynamically adjustable in steps of one minute from 1 to 15 minutes, or in a continuously varying “cycle” length manner. A new cycle information message must be broadcast whenever the cycle parameters change. Messages may be inserted several times into each cycle. This serves to reduce “acquisition” time, and improve the reception reliability of urgent messages.

Message priority was another issue where the EBU Guidelines on Broadcasts for Motorists have been followed, distinguishing mainly between strategic and tactical information. By definition, strategic information is of value for trip planning and route selection in the medium term, and tactical information is likely to be of relevance for immediate local diversions around current traffic problems. The following range of broadcast message priorities are considered:

- Highest Priority -- for immediate broadcast, interrupting ongoing RDS-TMC message cycles, and being repeated frequently;
- Tactical Information -- for non-delayed broadcast through early insertion into RDS-TMC message cycles, with frequent repeats;
- Strategic Information -- broadcast at fixed intervals according to RDS-TMC channel capacity; and
- Background Information -- broadcast less frequently, when channel capacity permits.

From the above, necessarily brief description of the RDS-TMC system, we see that it is a very versatile, well thought of broadcasting protocol, whose limitations are its inherent one-way characteristics, and the low data rate of 1187.5 bps.

#### *7.5.1.1.5.3.1.2 Modulation Sciences' SCA*

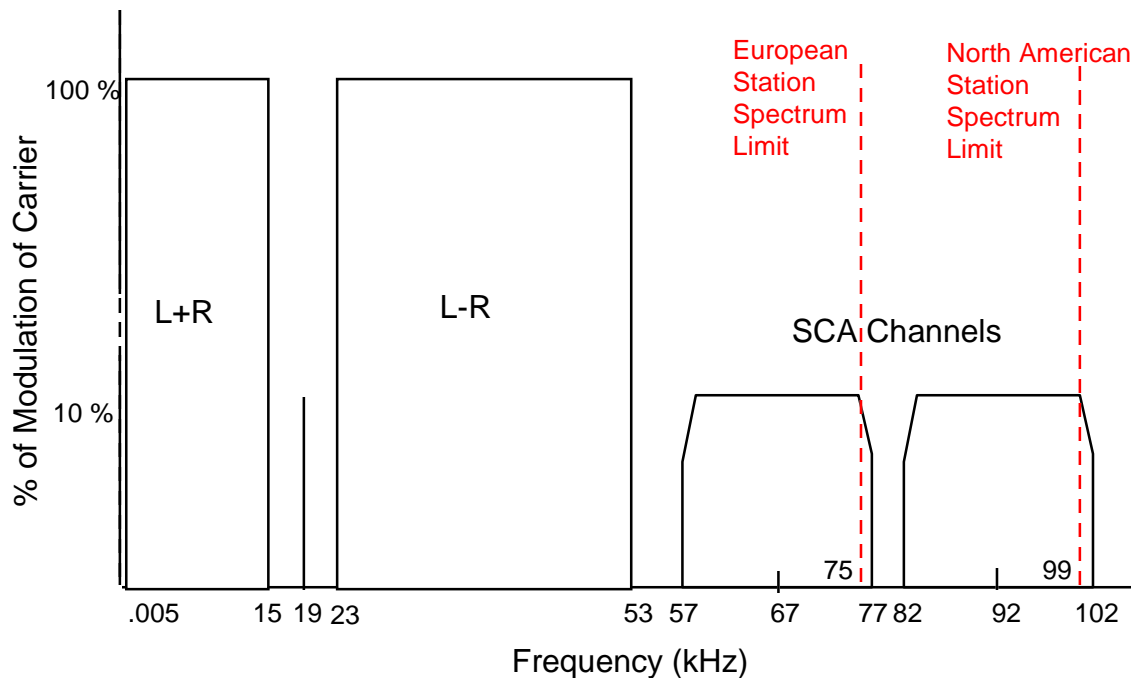
In this section, we analyze the system proposed by Modulation Sciences, Inc.<sup>10</sup>, one of the companies involved in FM subcarrier. **Error! Reference source not found.** shows the proposed use of spectrum. The basic SCA channel audio response is 50 Hz to 5 kHz, with 0-20 Hz sometimes available for low speed telemetry applications. Restricting the maximum modulation frequency to 5 kHz guarantees a bandwidth of 20 kHz for the SCA channel (in fact, the SCA channel bandwidth is only 14 kHz since the outer 3 kHz fall below the -25 dB threshold established by the FCC — that is why the upper SCA channel could be centered about 92 kHz). The lower SCA channel is compatible with the European standards, while the upper SCA channel can only be used in North America. (The two-SCA channel structure shown does not necessarily imply that one could not use the whole 53-99 kHz band to transmit data.)

The established use of SCA has been in stationary applications. The problems identified in this section limit SCA performance even in the stationary environment. Under mobile conditions, where the propagation conditions are significantly more severe, more problems and limitations will certainly develop.

---

<sup>10</sup>Eric Small, "Data SCA: Some Real World Experiences"; Eric Small, "Making SCA work in the Real World", Modulation Sciences, Inc.





**Figure 7.5-28 SCA FM Spectrum**

#### 7.5.1.1.5.3.1.2.1 Data SCA

Two types of data modulation have been considered for data SCA transmission, namely Direct and Indirect Data Modulation. In Indirect Data Modulation, also known as Compatible Modulation, the signal that goes into the SCA generator is a sequence of audio tones (AFSK). The advantage of this type of modulation is that standard (i.e., no-data) SCA generators can be used unmodified; thus cheap and easy to use generators are available. Disadvantages are the slow data rates that can be accommodated (less than 1200 bps), and the relatively expensive demodulator required to turn the audio back into data.

By switching the phase of an audio tone instead of its frequency, higher data rates can be achieved, but the cost of the receiver demodulator rises very rapidly with data rate, and, conversely, the tolerance of the system to interference (crosstalk) drops quickly. The advantage of this technique is that it employs the same technology used to send data via the telephone network; thus hardware is generally available, and is well understood. Usually data rates are below 9.6 kbps.

Direct Data Modulation takes advantage of something available to the FM subcarrier user, namely the subcarrier itself. The SCA subcarrier (at 67 or 92 kHz) is available for direct manipulation by the broadcaster. Instead of varying the frequency of an audio tone that in turn modulates the SCA subcarrier, the carrier itself is modulated. Higher data rates can be achieved with less bandwidth, and the receiver demodulators are cheap too.

Direct Data Modulation uses either MFSK, varying the frequency of the carrier itself, or MPSK, varying the carrier's phase. MPSK, however, requires a phase reference. Luckily, in FM stereo, an ideal external phase reference already exists: the 19 kHz pilot. A data rate of up to 46 kbps can be achieved with MPSK, occupying the entire SCA portion of the FM channel, from 53 to 99 kHz, but requiring a relatively expensive receiver. As a comparison, Modulation Sciences' Data Sidekick system achieves 4800 bps at a measured BER of  $10^{-7}$  for fixed links under "good" weather conditions.

In fact, the first and foremost problem of SCA, the one that limits the data rate, is multipath. Under fixed conditions, using appropriate antennas allows mitigation of the multipath to assure almost always a given BER. The biggest problem, even then, remains that of “equalizing” or “zeroing” late/undesirable reflections. (Especially in urban environments, the reflection coefficient in masonry varies widely, as much as 25 dB, depending upon its surface being wet or dry.)

7.5.1.1.5.3.1.3 SEIKO's High Speed FM Subcarrier Data System (HSDS)

SEIKO® Telecommunication Systems, Inc. (STS) has developed a flexible High Speed FM subcarrier Data System, known as HSDS, with a capability for world wide operation. HSDS is a fully developed one-way system providing messaging and information services (e.g., personal messaging, traffic information, time of day, news, weather, sports, business, and emergency information). The system has been deployed by STS under the Receptor™ trade mark in a number of cities (Portland, OR in 1990; Seattle-Tacoma, WA in 1992; Los Angeles, San Francisco, CA in 1995; a few East Coast cities in 1996). Coverage maps for some of these areas are shown in Figures 7.5-29 and 7.5-30.

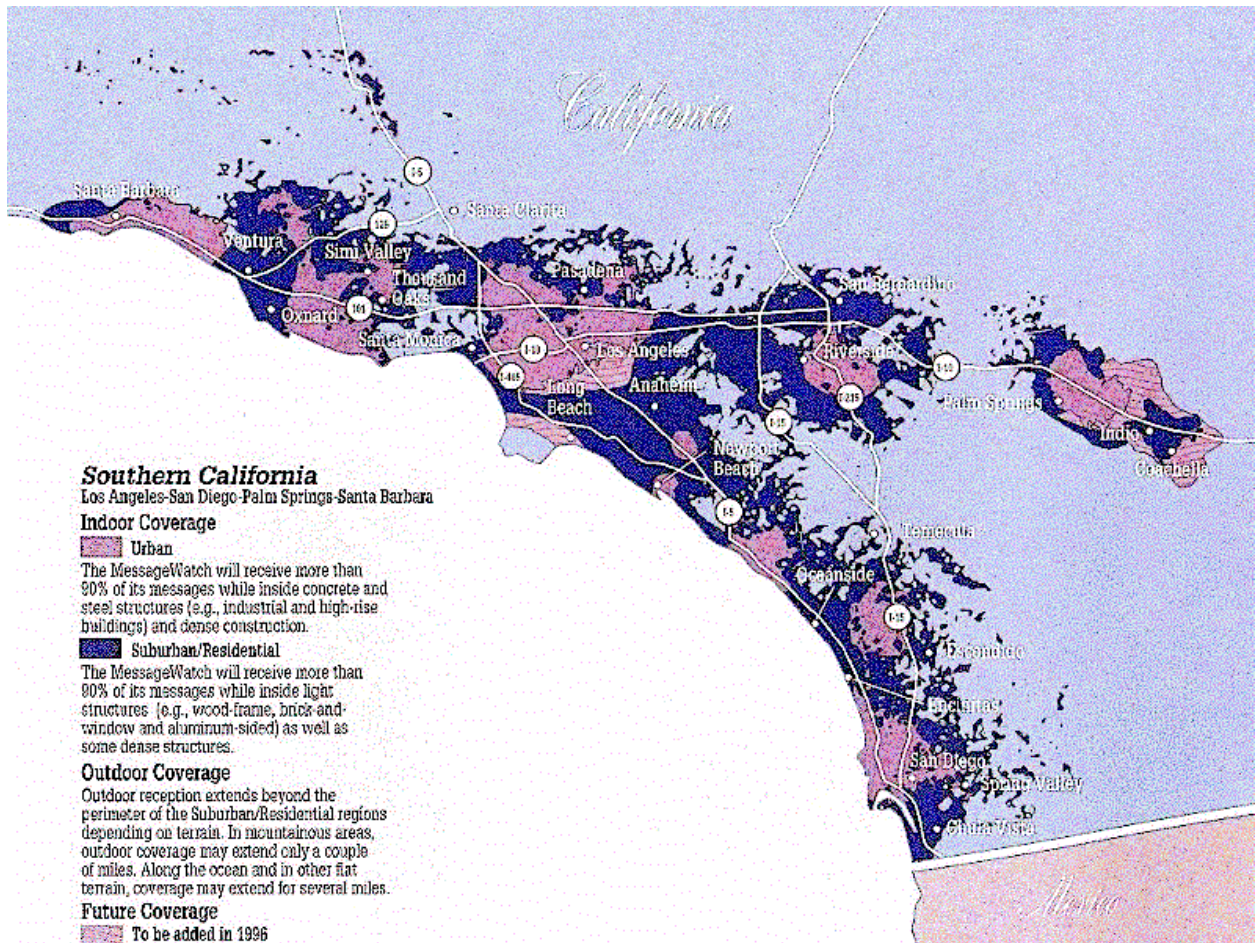


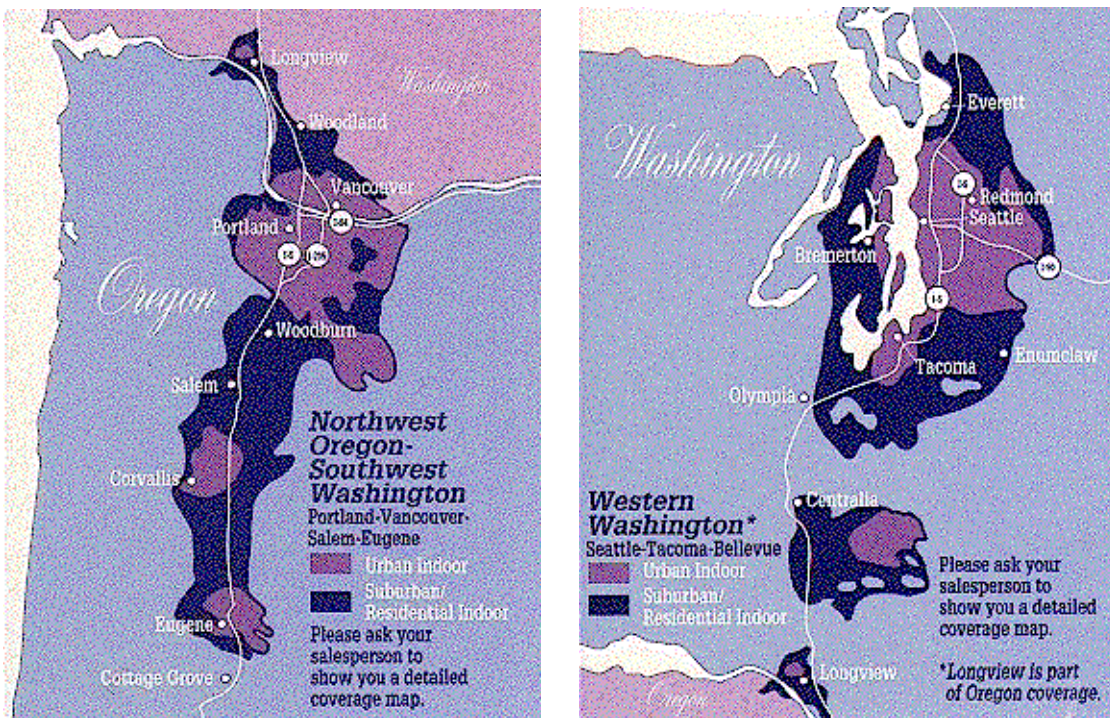
Figure 7.5-29 HSDS Coverage in the Southern California Area for Wrist-Watch Receiver (-29 dBi antenna)

The philosophy of the system design and operations is:

- The information is cyclically repeated at a rate of a few transmissions every 2-3 minutes. Therefore, if a user misses the information the first time due to blockage or error he/she will eventually receive it on the succeeding transmissions.
- The complexity of the handset is low. This has been achieved by using simple modulation and coding schemes, and using space, time and frequency diversity for mitigating multipath.

The HSDS utilizes existing FM radio broadcasting infrastructure, currently available IC's and transmission equipment, making it relatively inexpensive to deploy. By design it permits very small receivers: alphanumeric display wrist-watch receivers (SEIKO® Receptor™ MessageWatch™ which sells for \$75-150), and pocket pagers. Receivers with duty cycles varying from 100% to less than 0.01% provide flexibility to select message delay, data throughput, and battery life.

The HSDS can operate as a stand alone single station system, or as multiple systems operating independently in a geographical area with each system including multiple stations. Multiple stations are accommodated by frequency agile receivers, time offset message transmission in each station, and transmitted lists of stations surrounding each station (three FM stations provide coverage for 1.2 million people in Portland, OR; seven FM stations provide a coverage area with 2.6 million people in Seattle-Tacoma, WA).



**Figure 7.5-30 HSDS Coverage in the Portland, OR, and Seattle, WA, Areas for Wrist-Watch Receiver (-29 dBi antenna)**

#### 7.5.1.1.5.3.1.3.1 HSDS Technical Specifications

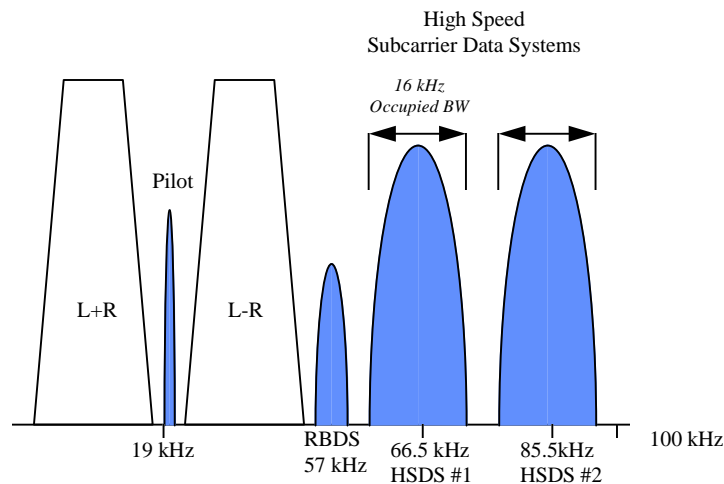
The HSDS system is time division multiplexed. Time is subdivided into a system of master frames, sub-frames and time slots. Each slot contains a packet of information. In multiple station systems, each

station's transmissions are synchronized to UTC ensuring synchronization between stations. The synchronized and time offset stations provide an opportunity to change the tuned frequency and make subsequent attempts to receive packets on other available frequencies.

Each receiver is assigned a set of slots as times for monitoring transmissions. (Multiple receivers may share time slots, due to the random nature of expected communications.) Each slot is numbered and each packet contains the slot number to permit rapid location of assigned time slots.

The error correction scheme is flexible, the methods used varying with the application. The method used for wrist-watch reception is designed to correct a short burst of errors associated with random noise or automotive ignition noise. The standard CCITT 16 bit CRC is typically added as a component of each packet, and minimizes the chances of "missed" packets.

HSDS' modulation/encoding provides high data rate, narrow bandwidth with high spectral efficiency (1 bit/s/Hz), and negligible impact on the main audio channel, or on any existing RBDS subcarrier. The HSDS modulation is DSB SC AM with duobinary encoding<sup>11</sup>; the data rate is 19 kbps in a 19 kHz bandwidth centered at 66.5 (=3.5 x 19) kHz. The HSDS signal is modulated as a subcarrier ranging from 5% to 20% -- typically at 10% on commercial FM radio stations. Sharp transmission filter skirts cause extremely little impact on the main audio channel in no multipath conditions; generation of a randomized data stream reduces the impact of multipath. The narrow bandwidth of HSDS allows for compatibility with RDS operation world wide. Furthermore, from Figure 7.5-31, HSDS allows for use of subcarriers above 76 kHz in the US, and compatibility with European spectral allocation.



**Figure 7.5-31 FM Baseband Spectrum usage for Seiko's HSDS System**

The effective information rate for HSDS system is 7500 bps (considering coding and repeat transmission overhead). The HSDS system transmits 72 packets of data per second, where each packet of data contains 104 bits of information. To reduce the impact (interference) on the audio channel, HSDS uses sharp skirt filters in addition to randomizing the data using PN sequences. As a result the data looks like random noise. A typical packet of data is first Encoded, then Randomized, and finally Interleaved .

SEIKO's HSDS system multiplexes data streams of varying bandwidths. As the transmission begins, bandwidth is dynamically assigned and subscribing receivers are alerted to the service. This bandwidth is

<sup>11</sup> A. Lender, "The Duobinary Technique for High Speed Data Transmission", AIEE Trans. Commun. Electronics, 1963.

then freed at the conclusion of the data stream transmission. Multiple data streams may be carried concurrently with small packet-oriented transmissions (such as paging and messaging).

**7.5.1.1.5.3.1.3.2 *Multipath and Shadowing Mitigation Strategy***

Robust wireless systems require methods to address multipath and shadowing. Some systems attempt to address these issues with extensive error correcting schemes. While these techniques are useful for the moving receiver, they become ineffective when the receiver is stopped in an extremely low signal strength area, or moving very slowly through multipath nulls. Diversity techniques are frequently used to combat fading effects.

HSDS addresses multipath and shadowing with a combination of frequency, space, and time diversity, and message numbering. Frequency diversity is achieved through frequency agile receivers (87.5-108 MHz). Space diversity (multiple station systems) provides paths from two or more directions reducing the size of shadowed areas, and the possibility of missed messages.

Time diversity can be provided in two ways: multiple transmissions on the same station, and delayed transmission between stations. Duplicated messages are rejected via comparison with the transmitted message number. Multiple transmissions of information several minutes apart are utilized for wrist mobile applications.

**7.5.1.1.5.3.1.3.3 *HSDS versus RDS-TMC***

A comparison with RDS-TMC, in particular with the RDS-ALERT C protocol, is warranted. From Table 7.5-10, we see that there is indeed a big difference in data rate in favor of HSDS. On the other hand, the cycle length is fixed for HSDS, although as we have seen, messages can be repeated within a cycle. In any case, HSDS seems to be a promising alternative to RDS-TMC.

**Table 7.5-10 Comparison of HSDS and RDS-TMC**

	<b>Center Frequency (kHz)</b>	<b>Bandwidth (kHz)</b>	<b>Raw Data Rate (bps)</b>	<b>Cycle Length</b>
<b>RDS-ALERT</b>	57	4.8	1187.5	<b>Variable</b>
<b>HSDS</b>	66.5	19	19000	<b>Fixed</b>

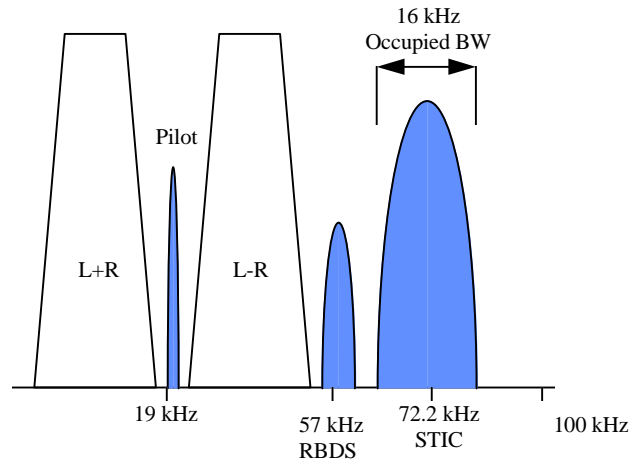
Although HSDS requires a reasonably inexpensive infrastructure, and relatively inexpensive, small receivers, it is still a proprietary one-way system. Nevertheless, it appears to be a promising substitute for lower rate R(B)DS systems.

**7.5.1.1.5.3.1.4 *MITRE's Subcarrier Traffic Information Channel (STIC)***

In early 1992 FHWA sponsored a research and development project for developing a high data rate subcarrier technology. MITRE/FHWA developed a high data rate subcarrier data system, and implemented a proof-of-concept prototype. The system is called Subcarrier Traffic Information system (STIC). STIC uses a complex data, and modulation format for defeating the multipath and other propagation effects. The prototype of the STIC receiver was tested in the Fayetteville, NC. The results of this trial were not available at the time of this writing.

#### 7.5.1.1.5.3.1.4.1 Technical Specifications

Figure 7.5-32 illustrates STIC's baseband spectrum.



**Figure 7.5-32 FM Baseband Spectrum Usage for MITRE's STIC System**

The STIC data format first uses convolutional encoding, and interleaving. The interleaved data blocks are further processed by appending to each block 4 channel state estimation bits. This data is then BCH encoded and followed by the  $\pi/4$  DQPSK modulator. The modulated signal is further filtered using the square root raised cosine filter with a roll-off factor of 0.68.

The parameters of the interleaver and coding are designed based on the propagation data in the FM band (100 MHz). The achievable information rate is 8 kbps, this is for a typical BER of  $10^{-5}$ . The raw symbol rate for STIC is 18.8 kbps.

The propagation parameters are a key element in selecting the parameters of the STIC waveform, such as the interleaver size, number of channel state bits, and encoding techniques. The typical values that have been considered for the evaluation phase are:

- Delay =  $3 \times 10^{-6}$  sec.
- Doppler spread of 8 Hz (at 55 mph for the 100 MHz band)

The complexity of the receiver will depend on the above parameters. STIC mitigates the propagation effects by using the channel state information to estimate the quality of the received data, thereby enhancing the decoding algorithm.

#### 7.5.1.1.5.3.1.5 NHK's Data Radio Channel (DARC) System

The Digital DJ Inc. and NHK of Japan are partners in developing the FM Subcarrier Information Services (FMSIS) for US applications. This system uses the data radio channel (DARC) technology developed by NHK Laboratories for broadcasting 16 kbps data using the FM subcarrier. DARC uses the level controlled minimum shift keying (L-MSK) modulation format, which is a variation of MSK. This modulation format has proven to be robust in a multi-path environment.

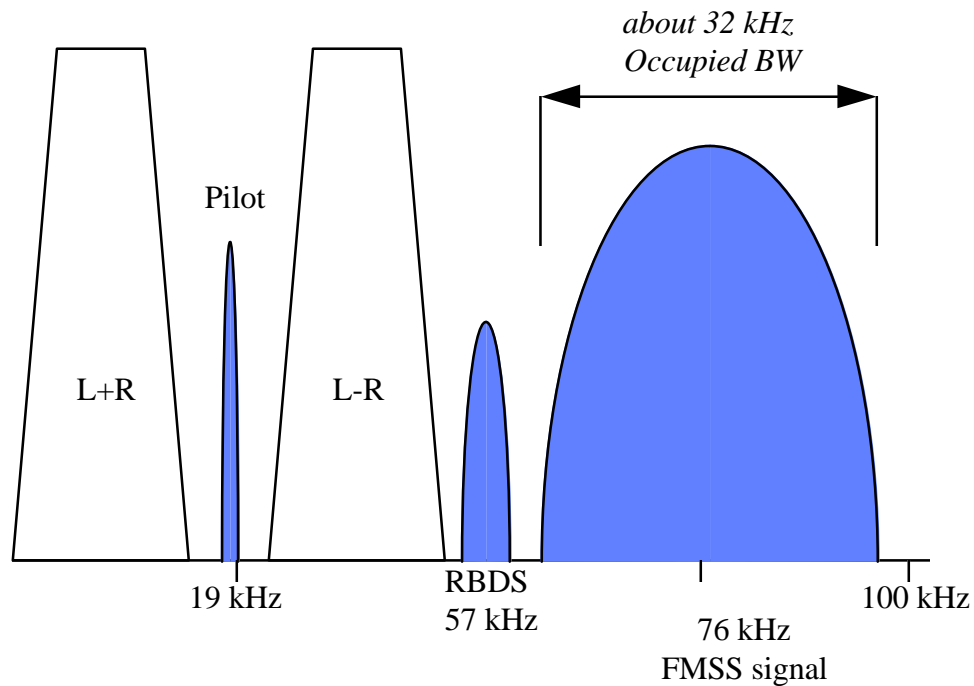
The level of the multipath in an FM subcarrier digital data system is related to the magnitude of the stereo sound level. At low stereo sound signal levels the multipath levels will be negligible when using low injection levels for the data signal. However, in the presence of higher stereo sound levels, injection

levels of 10% are required. By using L-MSK, which increases the injection level only during an increase in the sound level, the digital signals are transmitted efficiently under multipath conditions. Furthermore, DARC employs two dimensional CRC coding to correct channel and burst errors.

#### 7.5.1.1.5.3.1.5.1 DARC Technical Specifications

The FMSIS, using the DARC modulation format, places the digital data at 76 kHz baseband frequency, at a data rate of 16 kbps. This results in an occupied bandwidth of about 32 kHz. DARC's effective information rate, after error correction, is about 8 kbps or about 1,000 alphanumeric characters per second. The system is designed to co-exist with the low data rate RBDS system (Figure 7.5-33). The reliability of the system (% of correct reception) is improved by repeat broadcasting at a rate of 2 to 3 times every few minutes.

The receiver for the DARC system uses a chip set, developed by SANYO, for (1) filtering, (2) L-MSK demodulation, and (3) synchronization and decoding. The receivers will incorporate the chip sets to decode the received data and display the information using LCD panels.



**Figure 7.5-33 FM Baseband Spectrum Usage for NHK's DARC System**

#### 7.5.1.1.5.3.1.5.2 Field Test Results

In September of 1993 the DARC system was tested in Tokyo, using first generation receivers. The participants included both auto and radio receiver manufacturers. The trial included propagation test under (1) multipath conditions, (2) normal road, and (3) highway conditions. The results of this test presented the system bit-error-rate, and were used to estimate the system reliability (% of correct reception), under various conditions. The reported results claim reliability of 90 to 95% that can be obtained when using multiple repeat techniques.

In summary, DARC resorts to a more complex mobile unit, and lower per transmitter capacity to provide gains in reliability.

7.5.1.1.5.3.2 Evaluation Results and Conclusions

7.5.1.1.5.3.2.1 Capacity Analysis Results

The capacity of the broadcast systems is analyzed in the context of the ITS Architecture using the data loading analysis in Chapter 6 supported by Appendix F. The summary of these results is depicted in Table 7.5-10. The results present the aggregate information rate for traffic information services, travel information services and transit information services. The aggregate information rate is further evaluated for a growth rate of 10, 20 and 30 percent. The growth rate includes the increase in the number of links and the increase in the required update rates.

Table 7.5-10 presents the capacity of the high data rate FM subcarrier systems, viz., HSDS, DARC, and STIC, using a single and dual broadcasting channel. The capacity for these systems is evaluated at the three reliability factors of 100, 90, and 70 percent. The reliability factor accounts for the propagation impairments, such as holes in the coverage, multipath, blockage, etc. These results are presented assuming a single station operation, i.e., that if more than one station is used they do not supplement each other to increase reliability.

From Table 7.5-10, it is observed that the high data rate FM broadcast systems can meet the capacity requirements of the proposed ITS services which are presented in Section 6. Since the RBDS system and high data rate systems can co-exist, if desired, the RBDS system can also be used to support either a limited number of services or lower information update rates.

**Table 7.5-10 ITS Required Information Rates and Broadcast Systems Capacity**

ITS Services	Information rate per ITS service (bps)	Increase in information rate due to demand			High data rate broadcast system capacity effective information rate					
		10%	20%	30%	single channel at a reliability factor of			dual channel at a reliability factor of		
					100%	90%	70%	100%	90%	70%
Traffic information services	1,366	1,502	1,639	1,775						
Transit services	1,536	1,690	1,843	1,997						
Traveler Information Services	2,750	3,025	3,300	3,575						
<b>Total Broadcast Information Rate</b>	5,651	6,217	6,782	7,347	7,500	6,750	5,250	15,000	13,500	10,500

7.5.1.1.5.3.2.2 Coverage and Deployment Issues

The first approach to propagation mitigation uses multiple broadcast stations (i.e., multiple frequency bands), for transmitting the same information. Evidently the location of the FM towers in this case is of primary importance in optimizing the coverage area. The potential increase in the coverage area will result in an effective lower system capacity, since the same message will be broadcast from multiple stations. In this approach, the receivers will have the capability of tuning to multiple stations and selecting the strongest signal.

In the second approach, the broadcast system uses coding and modulation techniques for multipath rejection (STIC, DARC). Therefore, in general one FM station will be utilized per geographic area, to offer a certain set of services. However, these systems require receivers of higher complexity, compared to the first approach. In the complex mobile receiver approach the broadcast coverage could possibly be less than the first case, depending on the operational environment.



From the above discussion, the coverage and deployment, which are interrelated, depend on:

- The propagation environment – is one or multiple stations needed to meet the coverage requirements?
- The required capacity – are multiple stations needed to meet the capacity requirements?
- Available broadcast systems (number of the available FM subcarrier systems).

The coverage area can be determined and optimized by selecting the broadcast technology (i.e., RBDS, HSDS, STIC or DARC) that will best meet the capacity requirements and best fit urban propagation conditions.

#### 7.5.1.1.5.3.2.3 Interface Issues

The core of the FM subcarrier broadcast systems is the algorithm required for demodulation, encoding and multipath mitigation, and the hardware/firmware that it requires. The broadcast system developers have been integrating the receivers into a set of LSI chips for compact implementation. The issues that are involved in using broadcast systems include: (1) interface standards for inter-operability and nationwide compatibility, (2) licensing agreements for using the specific broadcast technology i.e., hardware and software, and (3) system integration, i.e., hardware interface with ITS user terminals

With the exception of the low data rate RBDS system that has an open and standard interface, all high data rate systems have proprietary interfaces (Table 7.5-11)

#### 7.5.1.1.5.3.2.4 Conclusions

Table 7.5-11 outlines the broadcast technologies' attributes. The high data rate FM subcarrier technologies that were analyzed in this document will meet the capacity requirements of the ITS data flows proposed for broadcast communication services.

The above analysis has also discussed the issues related to the coverage, interfaces, and national inter-operability. All high data rate systems that are discussed in this document (HSDS, STIC, and DARC) use proprietary hardware and interfaces, whereas RBDS uses a standard open interface. Using a system with a proprietary interface will impact the national inter-operability for the ITS services. The main issue in using a proprietary system will be the licensing agreements for the specific technology and hardware.

**Table 7.5-11 Summary of the Broadcast System Specifications**

Broadcast System	Status / Technology Maturity	Interface issues	Implementation	Special Features & Tech. for combating channels effects (e.g., multipath)	Data Rate	Inf. Rate
RBDS	Operational / Commercial	Open	Commercial		1187 bps	300 bps
STIC	Prototype/ Ready for deployment	Proprietary, licenced for free in U.S.	Prototype	Uses coding, interleaving & correlation techniques.	18.8 kbps	7.6 kbps
DARC	Operational / Commercial	Proprietary	Commercial		19 kbps	8 kbps
SEIKO, HSDS	Operational / Commercial (Oregon, LA, Seattle)	Proprietary	Commercial	Freq. and time diversity: scans for 7 Station, multiple transmission of the message, time offset between stations	19 kbps	7.5 kbps

Note: RBDS can co-exist with High Speed FM subcarrier systems.

The main issue in deploying FM subcarrier systems will be the need for standardizing the interface with ITS and achieving inter-operability between competing proprietary systems. Work is ongoing to standardize the high speed FM subcarrier systems. The work involves independent assessment of the three high speed systems, STIC, HSDS, and DARC, including their protocols and interfaces, by EIA at the NASA Lewis Research Center.

A subset of the ITS services that will not require high data rate can be broadcast using RBDS. Since RBDS has been standardized, those ITS services could easily achieve national inter-operability.

#### *7.5.1.1.5.4 Digital Radio Broadcasting (DRB)*

The 1992 World Administrative Radio Conference (WARC-92) decided the world-wide allocation for Digital Radio Broadcasting (DRB) in L-Band.

DRB will replace both FM and AM stations. For FM stations, the plan should accommodate DRB facilities which will provide for replacement of their existing coverage and have the potential to expand to the highest class of FM station. For wide-coverage AM stations, the objective is to accommodate stereophonic DRB facilities equivalent to the highest class of FM station. For limited coverage AM stations, the objective is initially to replace existing coverage, with potential to expand to the highest class FM station. (Coverage should be based on service in more than 90% of locations, 90% of the time for mobile reception.)

Industry Canada already announced the publication of a Draft Allotment Plan for Terrestrial Digital Radio Broadcasting (DRB) for stations operating within the 1452 to 1492 MHz frequency band (L-band) using the EUREKA 147 (DAB) system, following WARC-92's allocation of that band to DRB. (Canada introduced that proposal at WARC-92.) The 40 MHz of available spectrum was divided into 23 DRB channels. Each DRB channel can accommodate up to five CD-quality stereophonic programs and ancillary data. Up to five existing AM and/or FM broadcasters are grouped together to share the same transmitting facility.

A future DRB satellite component was also considered, and is anticipated for 2003-2005. In contrast, neither FM, at 88-108 M, nor AM, at 0.525-1.705 MHz are suitable for satellite signals.

#### *7.5.1.1.5.4.1 Digital Audio Broadcasting (DAB)*

Digital Audio Broadcasting (DAB), sometimes also called Data and Audio Broadcasting, uses innovative digital signal processing techniques for channel coding and modulation (COFDM) and audio compression (ISO/MPEG Layer 2). These techniques were chosen to ensure superb reception of CD-quality sound and various data services with mobile, fixed and portable receivers. Extensive tests have proven the validity of the DAB system, even under the most difficult reception conditions, e.g. in urban or mountainous areas with significant multipath effects and doppler shifts.

The DAB system is a wide-band digital transmission technology developed by the Eureka-147 DAB consortium. In cooperation with the EBU and ETSI, the standard of this new system has been finalized and recently accepted. This standard is now officially available and is known as ETS 300 401.

DAB offers the following features:

- mobile reception of audio in CD quality
- insensitivity to interference
- ease of operation
- efficient use of bandwidth

- low transmitter power
- opportunities for data, video and multimedia
- pay radio (Addressable radio)
- picture radio
- teletext, newsletters, narrowcasting

The DAB system has been proposed for adoption in Canada as an eventual replacement for existing AM and FM analog sound broadcasting.

Limited licenses have been issued in both Canada and Europe to broadcasters who wish to experiment using the digital transmission system by simulcasting their AM or FM broadcasts. The age of digital radio started with the launch of regular DAB services by Danmarks Radio (DR) in Denmark on 1 September 1995, followed by the BBC in the UK and by the SR in Sweden, both on 27 September 1995. DAB-based radio broadcasting will officially start in the year 1997 in Germany and Belgium; France, The Netherlands, and Australia are also planning their migration.

Satellite provisioning of DAB is under consideration in Europe and in Canada. Recently, BBC Research and Development, in collaboration with Telecomunicaciones de Mexico and the Instituto Mexicano de Comunicaciones, carried out successful satellite reception tests on Eureka DAB in the suburbs of Mexico City, using channels in the L-band provided by the Solidaridad 2 satellite. High-quality audio transmissions were successfully received from the satellite by both a fixed receiver and in a moving vehicle. This was the first test of mobile satellite reception using the Eureka 147 system.

Digital Radio Research Inc. (DRRI), a non-profit, research and development joint initiative of the Canadian Broadcasting Corporation and leading private broadcasting organizations, with financial support from the Canadian government, is conducting technical feasibility studies on the Archimedes mediaStar project, a satellite-based communication system using DAB technology. The proposed system, described as an "electronic multi-media kiosk", will use six HEO satellites in highly elliptical polar orbits to transmit wide-area audio and data services to mobile and fixed receivers in Europe, North America and East Asia.

#### *7.5.1.1.5.4.1.1 DAB versus RDS*

RDS, as we discussed before, is capable of offering some very useful features. However, there are two major differences between RDS and DAB which are important. Firstly, when compared with DAB, there is a very tight limit on the capacity offered by RDS. In France, for example, where TDF operates a paging service via RDS, Radio France is already unable to transmit the basic RDS features in conformity with the RDS specification guidelines, simply because so much capacity is used for the paging service. TDF already uses 70 % of the total capacity for paging alone. DAB, on the other hand, offers a much greater capacity for data services, and greater flexibility to trade off one application against another, not only data versus data, but also data versus audio. Secondly, only DAB can provide durability and reliability of transmission and can eliminate the multipath problems that plague FM reception in the car. This is the main advantage of DAB.

#### *7.5.1.1.5.4.1.2 Deploying DAB in the U.S.*

A note of caution is needed concerning the deployment of DAB in the U.S. At present in the U.S., L-band is used by licensed aeronautical telemetry and not available even for testing, let alone the establishment of a permanent set of frequencies for DAB. Even though spectrum is available in the U.S.

in S-band (2,300 MHz), if the U.S. established a Eureka system<sup>12</sup>, the standard would likely be out of step with the rest of the world. How this would affect the tuner manufacturers of the world is difficult to judge. It could mean that a separate band be installed in each tuner destined for the U.S. market, without the usual transportability between Europe and U.S. that exists with standard AM/FM.

#### 7.5.1.1.5.4.2 *In-Band, On-Channel (IBOC) System*

Since the Eureka concept was first introduced, alternatives have been suggested. The U.S. has fought against the use of L-band -- it was recognized that the inception of DAB on L-band would mean that 500 million radios would instantly become obsolete. In the view of many, the establishment of L-Band digital radio stations would result in the creation of a third radio band (in addition to AM and FM), a new band whose better-sounding stations would attract revenue away from conventional AM and FM broadcasters, which are already having problems generating sufficient profits in the crowded U.S. radio market. (This possibility is completely avoided by the Canadian government-industry plan to move all Canadian AM and FM stations to the L-Band.)

Competitors of DAB are basically six In-Band, On-Channel (IBOC) proposals whose objective is to produce cost effective, backward-compatible systems that can return the investment in the existing structure.

IBOC DRB has, however, not proven to be a solid competitor to DAB. In fact, in the U.S., DAB underwent testing by the Electronic Industries Association (EIA) and the National Radio Systems Committee (NRSC), and was declared a clear winner. Independent laboratory tests have confirmed that Eureka 147/DAB is the only digital radio technology capable of delivering CD-quality audio without interference to other stations. Test results indicate that proposed IBOC systems cause unacceptable degradation of AM and FM signals on adjacent frequencies as well as the host frequency. IBOC systems also experienced problems with adjacent digital signals interfering with each other in the crowded bands.

AM offers DRB the often overlooked advantage of favorable and extensive radio propagation characteristics. AM also offers DRB a readily available network of broadcasting facilities, including directional and nondirectional antenna towers and arrays, in place and operational at this time. The potential for delivering IBOC DRB in the AM band is too often dismissed due to potential technical challenges such as limited allocation bandwidth, interference due to market saturation and antenna pattern bandwidth considerations. However, USA Digital Radio, a company founded by U.S. broadcasters, has taken the position that both the infrastructure and the heritage of the AM broadcast industry are of a value that justifies meeting the technical challenges necessary to make AM IBOC DRB practical and realizable.

#### 7.5.1.1.6 Wide Area Beacon "Solution" to Wide Area Wireless

While it is true that beacons are more oriented towards short-range types of services and applications, the partition of ITS user services between wide-area and short-range wireless communication is not uniquely determined by (technical) system requirements. The purpose of this section is to discuss an alternative architecture in which some or all of the services in the first category are provided by short-range wireless communication between vehicles and roadside beacons (i.e., wide area coverage by means of widespread deployment of roadside beacons). The analysis is primarily from a technical and feasibility standpoint. The salient findings are discussed here and further details are provided in Appendix G.

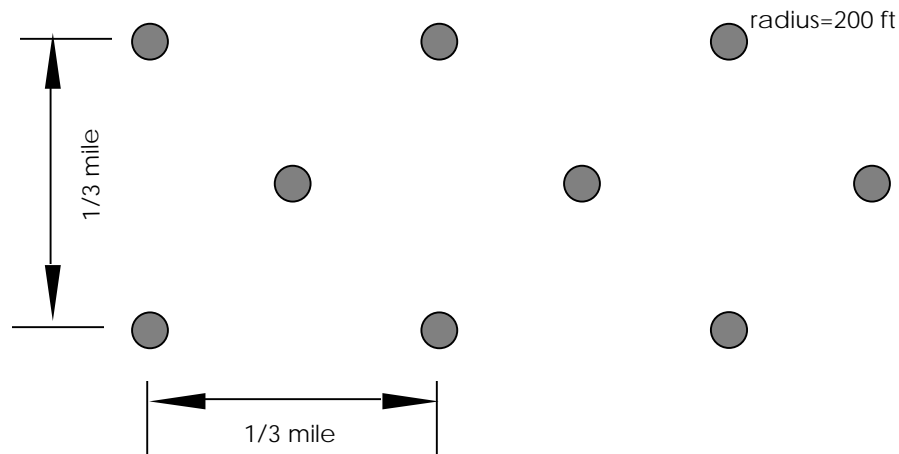
---

<sup>12</sup> DAB can function anywhere in the 30-3,000 MHz band.

#### 7.5.1.1.6.1 Coverage, Availability, Delay

Since all beacons in a given area use the same frequency, siting is constrained by the need to eliminate interference. For example, in Hughes' VRC system, receiver sensitivity is set to limit the effective range to about 200 feet. For acceptable interference levels, the minimum separation between beacons in the absence of obstructions is about 1/3 mile. This leads to the deployment shown below using cross-hatched circles. In an urban or suburban setting, however, the obstruction caused by buildings located on a rectangular street grid allows the siting of additional beacons without interference. Typically, the number of beacons can be doubled by locating the additional beacons (shown as dotted circles) equidistant from the original ones. We are thus led to postulate the idealized full deployment shown in Figure 7.5-34.

This coverage could be increased if frequency reuse were implemented, since beacons operating at different frequencies could be interspersed among those shown above. Such a system would then be no different from a full fledged micro-cellular system-- and would be prohibitively expensive for any dedicated set of users. Such a hypothetical situation, however, would defeat the essence of DSRC, which is based on very simple, inexpensive user equipment without sophisticated frequency agility. Thus, it will not be considered.



**Figure 7.5-34 Full Deployment of a Beacon System**

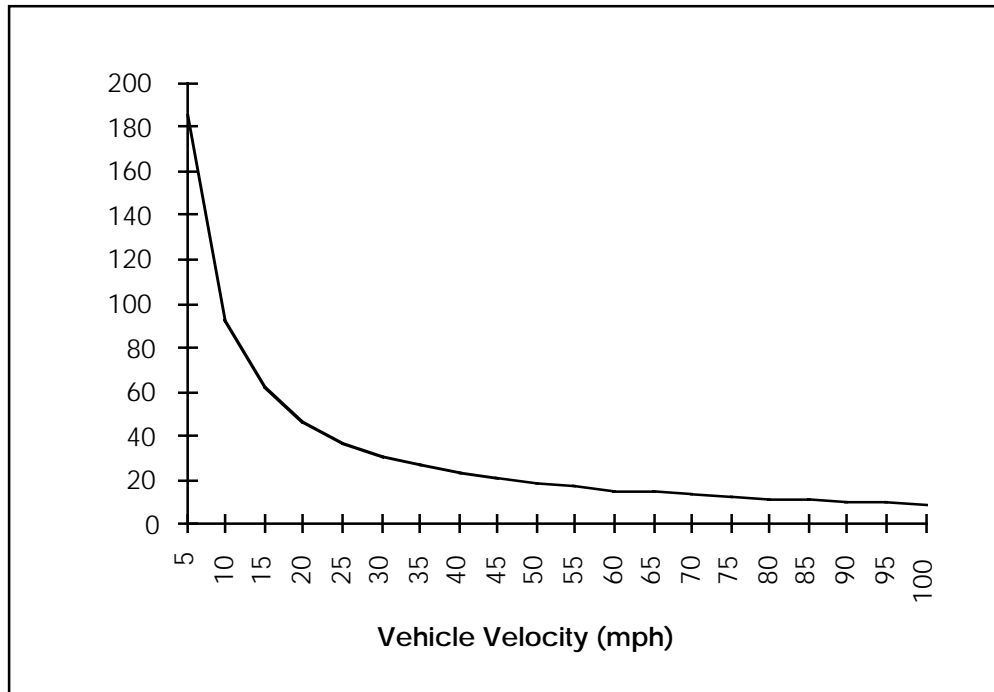
In the deployment shown in Figure 7.5-34, there are eighteen beacons per square mile, implying that literally tens of beacons will have to be deployed in the area covered by only one cellular base station. The postulated full deployment would greatly increase the number of devices which must be installed along roadways and connected via wired communication networks relative to a cellular-type solution, thus increasing the initial cost of such a system as well its maintenance.

For illustration purposes, the Urbansville scenario is examined. The Urbansville region covers 800 square miles. The postulated deployment requires a total of 14,400 readers. For comparison, 2560 intersection controllers and 111 ramp meter controllers are thought to be necessary.

Another key aspect of the indicated deployment is the small fraction of the total area actually within communication range of a beacon, which can be appreciated from Figure 7.5-34. That fraction is just  $18\pi(200)^2 / 5280^2 = 0.081$  (= 8.1%). However, given that the vehicles move essentially on surface streets and highways, it is more meaningful to compute the percentage of "linear" coverage, i.e., the fraction of the roadway length covered by the beacons. The fraction is slightly higher at  $(200 * 0.3) / (1609.3/3) = 0.112$

(= 11.2%). This immediately points out to the fact that only a small, similar percentage of the vehicles will be within range of such a fully deployed system. These small coverage factors also mean that time-constrained wide area ITS applications cannot be accommodated with such a system.

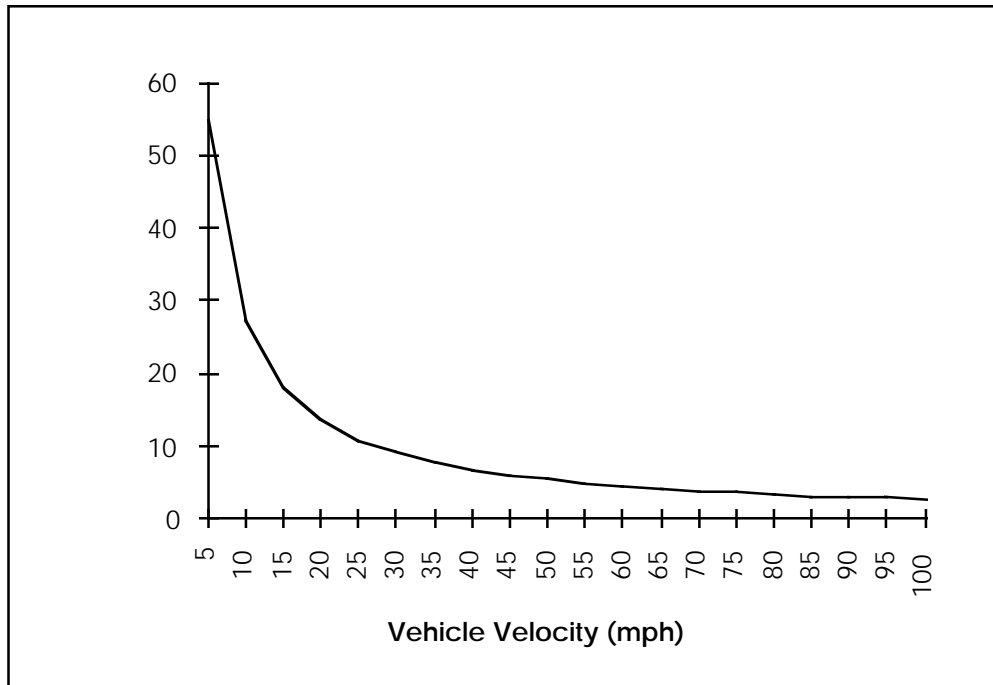
One of the serious drawbacks of wide area wireless communication using beacons is transmission delays which occur while a vehicle is located in a dead zone between beacons. This is, of course, most significant for vehicles which are traveling slowly or are stationary for some period of time as illustrated in Figure 7.5-35.



**Figure 7.5-35 Dead Zone Crossing Times**

For example, a vehicle traveling 10 mph requires 93 seconds to traverse the 1360 foot dead zone between beacons. Another more impressive result is that at 19 mph, the average freeway speed in the LA area during rush hour, the time to traverse the dead zone is still around 50 seconds. It is clear that such a beacon system cannot meet transmission time requirements for many ITS services.

Another drawback of a beacon system is the complexity required to carry out two-way communications between the TMC and vehicles which move from one beacon to another during the exchange. The time a moving vehicle will remain in the coverage area of a beacon is plotted in Figure 7.5-36.



**Figure 7.5-36 Beacon Coverage Crossing Time**

For example, a vehicle traveling at 60 mph will traverse beacon coverage (400 feet) in 4.6 seconds. For many traffic types, a query from the vehicle will elicit a response from either the TMC or a third-party provider. In many cases, the response will not be available until after the vehicle has left the coverage range of the beacon. Therefore, the TMC must direct its response to multiple neighboring beacons (see Appendix G). Compensating for location uncertainty will increase processing at the TMC or service provider and message storage at the beacons. In order to minimize wireless traffic, the beacon-to-vehicle communication protocol should restrict transmission of such responses to the first reader which establishes contact with the vehicle and transmits the response.

#### 7.5.1.1.6.2 Deployment Issues

A wide area beacon solution would imply extending the role of beacons from that of providing roadside-to-vehicle communications to that of providing wide-area communications.

Discussions of beacon system installation by government agencies versus using private cellular systems implicitly commingle two issues which in fact are quite distinct. The first issue is to compare the cost and technical merits of a “cellular” versus a “beacon” solution. The second issue is whether government agencies should allocate spectrum and fund the deployment of equipment to meet the needs of ITS for wireless data communications.

The fact that, currently, private operators are using “cellular” and that the government is focusing on “beacons” is not the result of an indissoluble link between these institutions and the methods they are using. It merely reflects the fact that engineers and planners on both sides have been solving different problems. Cellular operators have to serve high volume paying customers everywhere using crowded spectrum, while current beacon systems serve low volume, typically non-paying customers in sporadic spots. The different solutions adopted by each side reflect perfectly rational responses to different constraints, rather than any deep rooted differences in design methods. If beacons were economical for

providing universal wireless coverage, there is little doubt that the private sector would have deployed them. Conversely, if elevated antennas covering large areas were the best way to operate toll systems today, it would be surprising if this was not indeed the approach taken by the government.

An examination that separates the merits of government support of ITS communications from the merits of beacons provides the following conclusions:

- 1) Government support does not appear needed to stimulate wireless data provision. The government may help wireless in general by allowing use of its property to install antennas. Private sector participants are the most likely to bring to end users the benefits of the lowest cost approaches through technological innovation spurred by competition.
- 2) Beacons are not appropriate for high volume, continuous coverage service such as the wireless data services required by ITS. The beacon's disadvantages in such applications are their inefficient use of bandwidth (with current modulation technologies), the high number needed for deployment to match low U.S. population densities, the gaps in coverage due to simplistic frequency reuse, and finally the need to start from ground zero compared to installed cellular systems whose costs are shared by many users.
- 3) Using beacons for wide area coverage does not appear economic now. If using beacons later becomes the most economic approach to providing wide area wireless data, then the private sector can be expected to provide that solution too. There does not appear to be a need for the government to fund wide scale installation of beacons at this point.

### **7.5.1.2 Short Range ITS Communications**

#### **7.5.1.2.1 Communications Between Vehicle and Roadside**

There are three candidate technologies for the short range wireless communication link between the vehicle and the roadside, i.e., v2 links. These are active RF, passive (modulated backscatter) RF, and infrared. This section presents some of the technical features of these technologies. Although each of the underlying technologies is capable of a wide range of technical performance, this comparison will be restricted to the specific features which have been commercially implemented, and to varying degrees, incorporated into standards for each technology. This is consistent with the Joint Team's approach to standardization which is to emphasize adoption of standards for existing technologies rather than introduce new infrastructure.

A number of vendors have produced or are proposing active RF DSRC equipment. These systems are generally proprietary and not inter-operable. Of these, the Hughes' VRC system seems to be among the most advanced technically and also seems to be the subject of a well-advanced standardization process. Among the applicable standards are a draft version of the *Electronic Toll and Traffic Management (ETTM) User Requirements for Future National Inter-operability* prepared by the ETTM User Group of the Standards and Protocols Committee of ITS America, and a draft *Standard for Dedicated, Short Range Two-Way Vehicle to Roadside Communications Equipment* being prepared by the ASTM. The Hughes' VRC system is described, and some aspects of its performance are analyzed in the beacon analysis presented in Appendix G. Some specifications for this system are listed in Table 7.5-12 for comparison with the other beacon technologies.



**Table 7.5-12 Beacon Systems Specifications**

<b>System</b>	<b>Maximum Range</b>	<b>Data Rate</b>	<b>Transmit Block Size</b>	<b>Tag Data Storage</b>
Active RF	200 ft	550 kbps	512 bits	not known
Passive RF	75 to 100 ft (with extended range reader)*	300 kbps (600 kbps optional)	128 bits	20 frames of 128 bits
Infrared	not known	125 kbps	256 bytes (forward), 128 bytes (reverse)	not known

\* exact range depends on antenna gain and power setting

Passive RF beacon systems produced by Amtech have achieved a significant number of permanent installations in the U.S. and worldwide, primarily for toll collection. Recently, a partnership named Intellitag Products, jointly owned by Amtech and Motorola, has introduced an upgraded product line which is claimed to be compatible with the previous Amtech products. It is also claimed that operation is compliant with the open protocol detailed in the *AVI Compatibility Specifications* in Title 21 of the California State Code of Regulations. Some specifications for this product line are also listed in Table 7.5-13 for comparison with the other beacon technologies. Some other features are of interest. Transmit frequency is programmable in 1 MHz steps from 902 to 928 MHz. This feature aids non-interfering operation of readers in adjacent lanes, since they can transmit at different frequencies. In addition, external synchronization signals can be supplied to the readers so that they transmit at different times. Note however, that this reduces overall throughput. Transmit power level is programmable in 1 dB increments from 50 to 500 mW.

Infrared beacons developed by Siemens form part of the ALI-SCOUT dynamic route guidance and interactive transport management system. This system has undergone trials in Europe (the LISB project in Berlin) and is currently being tested in Michigan (the FAST-TRAC project). The beacons transmit a sequence of up to 40 blocks of data of duration 17.5 ms, each containing 256 bytes of data. The beacon is “silent” for an interval of 11 ms following each data block to allow vehicle tags to respond with a single block of data. The vehicle tag’s data block is 8.5 ms in duration and contains only 128 bytes. Although the vehicle tags implement a simple randomization mechanism to select which interval to respond in, destructive collisions will occur when multiple vehicles are within range of the reader. When the reader successfully receives a data block from a tag, it acknowledges reception in its next data block.

From a purely technical standpoint active RF beacons have a number of advantages over passive RF beacons. Among these are:

- The use of an active tag inherently gives greater range for the same reader transmit power and antenna gain. This facilitates covering traffic in multiple lanes with a single reader.
- The use of TDMA with reservation slotted-Aloha access protocol allows simultaneous handling of a larger population of vehicle tags. This also facilitates covering traffic in multiple lanes with a single reader.
- The larger packets (512 bits versus 128 bits) used in active RF give more flexibility for applications which may require greater data transfer than electronic toll collection.

On the other hand, passive RF systems offer the advantage of lower cost tags. In fact, tags are available which obtain all of their power from the received RF signal and hence require neither a self-contained battery or connection to the vehicle electrical system.

At this point in time, limited data is available on the performance of infrared beacons, therefore it is difficult to compare them with either of the RF technologies.

The foregoing technical comparison suggests that active beacons are superior to passive beacons. However, in comparing beacon technologies for use in the ITS communication architecture we must keep in mind the particular functions which have been allocated to the u2 communications link. The proper basis for comparison is the degree to which the beacon technologies fulfill the requirements of these functions.

In the Joint Team architecture, the applications served by the u2 interface are toll collection, parking fee collection, CVO in-motion inspection, and pre-clearance and in-vehicle signing. All of the technologies should be capable of successful deployment in situations where vehicles are restricted to lanes and one reader is deployed per lane. This will certainly be the case for parking fee collection and will probably be the case for toll collection due to the need to handle both equipped and non-equipped vehicles. For these applications there is no basis for prescribing one technology over another, so the architecture should start by accommodating all emerging standards and allow the marketplace to drive deployment. Since passive RF systems already have many proven installations, and also offer lowest cost tags, it is likely that they will capture a significant share of the market. Hence, they cannot be dismissed in favor of higher performance beacons.

In the remaining applications, CVO in-motion inspection and pre-clearance and in-vehicle signing, it may not be desirable to restrict vehicles to particular lanes. In these cases it appears that the technical advantages of active RF technology will provide superior performance. In this case it seems likely that they will capture a significant share of the market. Again, the architecture should accommodate the emerging standards for active RF technology.

In the scenario described above, both passive and active RF beacons are seen to capture somewhat distinct market segments. The role of infra-red beacons is harder to predict. In one sense this is not ideal, since two standards must be supported. On the other hand, the existence of only two standards would be a great improvement over the current situation in which many vendors provide non-inter-operable systems. To eventually achieve national interoperability, which would be very advantageous for the set of services considered here, a single common standard will need to emerge, perhaps spurred along with encouragement from the FHWA.

#### 7.5.1.2.2 Vehicle-to-Vehicle Communications

VtoVC requires a high data rate, and a bursty, usually line-of-sight transmission with high reliability between vehicles. It is still in the research stage, both in the U.S. and in Europe. Solutions in the U.S. tend to stay in the low GHz bands (e.g., 1 and 2 GHz band spread spectrum systems, and some 5 GHz band TDMA systems). The European solution of choice seems to be the 60 GHz band, where the H<sub>2</sub>O absorption phenomenon does not affect, and on the contrary facilitates, the short range communications involved.

It is in the AVSS and AHS areas that V2VC plays an important role, although the feasibility and practicality of using VtoVC for AVSS purposes has been questioned by many. The clearest example is Intersection Collision Avoidance, one of the 29 user services. It does not easily lend itself to VtoVC implementation-- reasons are the interaction with pedestrians, and the need to set the detection threshold to keep the number of false alarms within an acceptable range (and this is a theoretical, fundamental limit that has to be dealt with).

The most ambitious ideas, however, have to do with an intrinsically European concept of "co-operative driving". Essentially, the vehicles would broadcast to their neighborhood their status, any upstream information of interest such as, road conditions, incident reports, etc. How this information would be obtained is another question. (Perhaps from the involved vehicles.) Mainly, vehicles would broadcast information regarding their intentions (e.g., passing, veering right/left). The essential questions, that fortunately we do not have to answer (that is left in the capable hands of the AHS Consortium), are: how

will the vehicles make sense of the barrage of information impinging on them? How to prioritize them? How to make sure they get any information deemed important, especially if they come to rely on it?

In order for these external warnings to be effective, the target vehicles have to be properly equipped (which raises the issue of compatibility at a national level), and a minimum penetration realized before any benefits will be observed. That threshold is obviously very difficult to predict.

In AHS, Vehicle-to-Vehicle communications are essential to the concept of platoons, groups of vehicles on the same highway traveling in the same direction in near proximity, where the stability of the platoons is conditioned on all the vehicles knowing exactly what all other elements of the platoon, and especially the leading vehicle, are doing (speed, acceleration). Vehicle-to-Vehicle communications are even more important to enable the formation and break-up of platoons. So, AHS is not likely without Vehicle-to-Vehicle communications, and will only be possible for so equipped vehicles.

In spite of the fact that through ISTEA Congress has mandated the US DoT to develop an operational AHS test track by 1997, little has been done in the area concerning Vehicle-to-Vehicle communications. To the Team's knowledge, only one trial has been performed in the U.S. involving Vehicle-to-Vehicle communications. The test was performed by PATH (U.C. Berkeley) involving four vehicles provided by Ford Motor Company, each equipped with an Integrated Platoon Control System (IPCS) unit consisting of (off-the-shelf) model 386 PC, a spread spectrum communication system, radar system, sensors, and actuators. The radar system was provided by VORAD Safety Systems, Inc., San Diego, CA.

The control algorithm running on the PC requires data to be transmitted from one vehicle to another. A communication system was designed consisting of a roof-mounted antenna, a PROXIM digital transceiver, and a Metacomp communication interface board. The communication was half-duplex at the rate of 122 kbps in synchronous mode. The frequency used was in the 902-928 MHz band, approved by the FCC for unlicensed low-power use. Using the radio link, the speed and acceleration measurements of the lead vehicle were transmitted to the following vehicle(s) every 55 ms (18 Hz update rate). The controller in the following vehicle used these measurements to calculate the proper action to keep constant headway depending on the lead vehicle's motion.

The small size of the trial, and the fact that the communication between vehicles occurred without interferers (some kind of round-robin method was used to time the transmission of the different vehicles so that each was appropriately staggered, never to coincide with another vehicle transmission), makes this too ideal a trial even to be a proof of concept. However, the experience demonstrated that constant-spacing vehicle-follower longitudinal control can be implemented on a small group of vehicles with reasonable accuracy and ride quality, by using a combination of ranging sensors and vehicle-to-vehicle communication, together with a sophisticated non-linear control law.

In parallel, PATH (U.C. Berkeley) is working to define the communication requirements for AVCS, involving both vehicle-to-vehicle and vehicle-to-roadside links. Under consideration is the information needed for vehicle control, the reliability requirements, and the physical means for implementing the communication links, with particular attention to narrowband radio communication approaches that make efficient use of spectrum. On the other hand, PATH (USC) has investigated an integrated spread spectrum communication system combining vehicle-to-vehicle and vehicle-to-roadside communications. PATH is also involved in a comparative evaluation study of the performance of vehicle-to-vehicle communication systems, based on a technical performance specification under development.

In Europe, and under the aegis of the RACE Program, theoretical work has been proceeding in the area of vehicle-to-vehicle communications in the 6 and 60 GHz bands<sup>13</sup>. Pure TDMA schemes are under investigation for this application; this in spite of the fact that a common slot synchronization is a major problem since there is no master station providing synchronization information. However, local

synchronization may be sufficient given that there is no reason why far away (few miles) vehicles must be synchronized — this implies the capability of mutual synchronization between vehicles.

In Japan no work is being done, to the Team's knowledge, in the vehicle-to-vehicle communication area, the effort being concentrated in the vehicle-to-roadside area. In fact, some analysts reason that given dense enough a coverage (which, as observed in the Beacon analysis, is not possible without some kind of frequency reuse or without some kind of multiple access mechanism like CDMA or TDMA), vehicle-to-vehicle communication could be accomplished through the infrastructure (*i.e.*, vehicle-to-vehicle-via-infrastructure or vehicle-to-infrastructure-to-vehicle).

In summary, for systems to be deployed well into the 21st century (possibly late 2020's), little has been done, and even less can be guessed at what will be available for deployment at that time. Never the less, it is essential to probe into the problems likely to arise in the complex environments of surface streets and highways of the future and the future technologies required for automated highways.

Quoting Prof. Shladover<sup>14</sup>, much of the most research-intensive effort needed to bring AVCS to deployment will have to be in the development of enabling technologies. These have to do with the subsystems or components that need to be combined to produce fully functional systems. In most cases, the enabling technologies are applicable across a range of functional areas, and are certainly not exclusive to AVCS. However, in many cases the performance and reliability requirements for AVCS exceed those for other functions (wide emphasis on safety in AVSS). Below is a list, by no means exhaustive, of technologies where some progress is being done.

- Ranging Systems
- Other Sensors
- Integrated Computer Control and Data Acquisition Systems

## 7.5.2 Wireline Communications

Wireline network options include the use of private networks, public shared networks, or a mixture of the two. Examples of private network technologies are twisted pair cables, FDDI over fiber optic rings, SONET fiber optic networks, and ATM over SONET networks. Examples of public shared network options are the leasing of telco-offered services such as leased analog lines, frame relay, ISDN, metropolitan ethernet, and Internet. A third wireline network option is that of a mixed network, where existing communications infrastructure can be utilized to the greatest extent possible, and possibly upgraded to carry any increased data load. The addition of CCTV in particular can overload the backbone of an existing network.

The decision to specify a private network is probably not motivated by technological reasons because the desired data bandwidth can be supplied through the use of public shared networks. Much as the choice of technologies like CDPD for the wide-area u1 interface has many advantages such as cost sharing and risk reduction, shared wireline links have many similar advantages. It is certain that in the time frames studied that one or more local carriers can provide a network connectivity to fulfill the ITS requirements.

The reasons for building a private network have more to do with requirements/preference for a network built to the exact specifications of the user, and with matching the funding mechanism. If one-time capital funding is more easily obtained than monthly lease fees, then a private network appears as the best choice. In any case, there will still be an ongoing maintenance cost.

The active participation of the owners of the roadway right of ways in partnership with one or more commercial carriers may be a means of having a private network built for the ITS infrastructure at little or no cost to the local agency. In exchange for the use of the rights of way, the carriers would provide a portion of the network capacity for ITS use, and much of the maintenance cost.

For the purposes of the communication analysis, the owner of the network is not an issue, nor is the exact technology used on each link an issue. The goal was to demonstrate that the wireline data loads derived in the data loading models, both between the fixed entities in the Urbansville infrastructure model presented, and between the fixed and the mobile entities, can be carried comfortably using link technologies currently available or expected to be deployable in the time frames of interest. The candidate network technologies studied included those that are standardized (or will be in the time frames of interest) and are available in commercial quantities. To reach that goal, several network technologies were studied, and then a subset of those network technologies were incorporated into communications simulations models and performance results were determined.

The choice of a network technology for a deployed network must be based on the specific details of the infrastructure assets deployed in the specific metropolitan area. Any conclusions drawn in this analysis should not be generalized to every deployment area.

### ***7.5.2.1 Candidate Wireline Technologies***

The candidate network technologies discussed below are chosen from standardized network technologies because they consist of components available from multiple vendors. There are no added development costs, they are compatible with public shared networks, and they have been tested in various environmental conditions. The candidate private network technologies studied here include Ethernet, Fiber Distributed Data Interface (FDDI), Synchronous Optical NETwork (SONET), and Asynchronous Transfer Mode (ATM).

In addition to the network technologies listed above, the use of twisted-pair copper lines for the lowest level in a network is considered as a cost saving means of transmission. This allows the reuse of existing twisted-pair infrastructure. For new construction, the cost of fiber with optical transceivers is close to the cost of twisted pairs with modems.

Ethernet is a network technology based on a bus, primarily used in local area networks. The data rate is typically 10 Mbps, and the transmission media is coaxial cable. Access is controlled by a media access protocol (MAC) incorporating a Carrier Sensing Multiple Access with Collision Detection (CSMA/CD) scheme. The access protocols cannot accommodate networks covering a large area efficiently. To cover a metropolitan area the network must be broken down into many smaller LAN areas, which are then linked together using high-speed links. The CCTV camera load in any reasonable area would probably exceed the data capacity of ethernet, so a separate network would be required to carry the video data.

FDDI is a LAN-based network technology using a fiber optic transmission medium. It can support a data rate of 100 Mbps, and a total network cable length of 100 km. Up to 500 stations can be linked on a single network. Although a logical ring network topology is required, FDDI can support both star and ring physical topologies. Access to the ring is controlled by a token-passing scheme: A station must wait for a token before transmitting, each station repeats any frames received downstream to the next station, and if the destination address on a frame matches the station address, it is copied into the station's buffer and a reception indicator is set in the frame status field of the message which continues downstream. The message continues downstream through the network to the originating station which then removes the message from the network. An enhancement to FDDI was standardized as FDDI II, which provides a circuit mode of operation. It allocates time slots of FDDI to isochronous channels. Up to sixteen, 1.144 Mbps channels can be allocated, with a 1 Mbps channel remaining for a token channel. Using this standard would allow constant-rate data from CCTV cameras to be transmitted on the isochronous channels with the remaining time slots available for the asynchronous (packet) data from intersection controllers and sensors.

SONET is an optical interface standard for networks that allows inter-operability between equipment manufactured by different vendors. It defines the physical interface, optical line rates, frame format, and operations, maintenance, and provisioning overhead protocol. The base rate of transmission is 51.84 Mbps, and higher rates are allowed as multiples of the base rate. At the base rate, data are transmitted in frames of 90 by 9 bytes every 125 microseconds. Higher rates are achieved by transmitting a multiple number of these frames every 125 microseconds. The first three “columns” of the 90 by 9 byte frame are reserved for overhead data, and the rest constitute the “payload” of 50.11 Mbps. The synchronous structure and byte-interleaved structure of SONET allows easy access to lower-order signals, which allows the use of lower- cost hardware to perform add/drop, cross-connect, and other bandwidth allocation techniques, eliminating the need for back-to-back multiplexing/demultiplexing. The overhead allows remote network monitoring for fault detection, remote provisioning and reconfiguration of circuits, reducing network maintenance costs. SONET networks can be configured as point-to-point or ring networks. For fault redundancy, SONET rings are frequently configured as bi-directional rings with one-half of the network capacity reserved for transmission during a fault. In the case of a cut in the two fibers (one for each direction) between two adjacent nodes on the ring, traffic is rerouted by the nodes on either side of the break, in the direction away from the break, using the reserved excess capacity of the ring.

ATM is a packet-switching technology that routes traffic based on an address contained in the packet. Packets are statistically multiplexed through a store-and-forward network, allowing multiple data streams of various data rates to flow through the network with greater instantaneous link efficiency. The technology uses short, 53-byte fixed-length packets, called cells, allowing the integration of data streams of various rates. The short cell length limits the length of time that another cell must wait before given access to the link. Cells containing video data can be given a priority over data cells, so that continuous video streams will not be interrupted. The 53-byte cell consists of a 5-byte header and 48 bytes of user data. ATM is connection oriented, and every cell travels through the network over the same path, which is specified during call setup. The cell header then contains only the information the network nodes need to relay the cell from one node to the next through the network. ATM connections exist only as sets of routing tables stored in each switch node, based on the cell header. Each ATM switch along the route rewrites the cell header with address information to be used by the next switch node along the route. Each switch node needs to do very little to route the cell through it, reducing switching delay. ATM can be used on a variety of links, and particularly SONET links for the medium-haul lengths required in a metropolitan-area deployment. The ATM concept, being based on switches routing packets, tends to favor a star configuration with a dedicated line to each user. ATM is still in the development phase, but should be considered as one of the strongest network technology candidates for the deployment time frames being considered.

### **7.5.2.2 Candidate Wireline Topologies**

Network topologies were studied in Phase I of the National Architecture Program by the Rockwell Team (section 6.3.2.2 of *IVHS Communications Network Requirements Document*) for purposes of making preliminary determinations of the total physical length of links and data rates required on links given topological assumptions. Communications simulations were run on several fundamental candidate network designs to provide throughput and delay statistics. The goal at this point was to demonstrate that the data can be carried on the candidate networks, and to provide a rough cost for such a network.

The network connecting the sensors and intersection controllers to the TMS will be at least a two-level network, with the first network level connecting the sensors and intersection controllers to a hub in the center of each section, and the second network level connecting each of the section's hubs to the TMS. An additional network level may be added as a set of concentrators deployed throughout the sections to concentrate data over higher-rate lines to the hub. This was contained in the type-C section by clustering

the intersection controllers into groups of eight, with a single connection to the hub. Concentrators were applied in the network where they can be used to decrease the overall network cost.

The use of star connectivity was studied for both levels of the network. The selection of a ring or star network configuration is largely determined by the link transmission technology selected, such as private FDDI networks, and public leased twisted pairs. Examples of some of the connectivity options and their effect on the total length of links was analyzed. The results of the simulations showed clearly that the delay on any reasonably designed wireline network was completely negligible.

### 7.5.2.3 Public Network Usage

The candidate shared public network technologies include leased analog lines, digital leased lines, frame relay, Integrated Services Digital Network (ISDN), metropolitan ethernet, Switched Multimegabit Data Service (SMDS), and Internet.

Portions, or all, of the communications links for the architecture can be provided by shared public network technologies. The public network technologies that can be considered to fill a large subset of communications requirements, and are available in most jurisdictions are detailed in Table 7.5-13.

**Table 7.5-13 Widely Available Public Network Technologies**

<b>Link Technology</b>	<b>Analog leased lines</b>	<b>Digital leased lines</b>	<b>Frame Relay</b>	<b>ISDN</b>	<b>SMDS</b>
<b>Type of service</b>	Dedicated circuit	Dedicated circuit	Packet switched	Circuit switched and packet	Packet switched
<b>Transmission medium</b>	Standard telephone line	Digital facilities	standard telephone line to four-wire T1 technology	basic rate ISDN - standard telephone lines; primary rate ISDN - four-wire T1 technology	four-wire T1, and fiber optics
<b>Data rate</b>	up to 28.8	2.4 Kbps, 64 Kbps, fractional T1, T1 (1.5 Mbps), T3 (4.5 Mbps), DS3 (45 Mbps)	56 Kbps up to T1	Circuit switched B channel 64 Kbps, packet D channel 16 Kbps; basic rate ISDN=2B+D, primary rate ISDN = 23B+D	T1, T3, SONET to 155 Mbps
<b>Capabilities</b>	point-to-point and multipoint	point-to-point and multipoint	Suitable for data only.	B channel well suited for CCTV which can be used intermittently, D channel for simultaneous data	Suitable for data only.
<b>Comments</b>	Universally available	High reliability	Fixed monthly charge based on data rate	Cost is usage dependent	Cost is usage dependent
<b>Cost/month (rough estimate, based on undiscounted tariffs )</b>		56 Kbps: \$300/month; T1: \$3.50/month/mile + \$2500/month; DS3: \$45/mile/month+ \$16000/month	56 kbps: \$175/month T1: \$435/month	basic rate ISDN: \$25/month + \$0.57/kilopacket for data and \$0.016/minute for B channel	

Metropolitan ethernet may be available in some jurisdictions as a service provided by CATV companies. This shared network is currently found in only a few metropolitan areas, but could be offered in many more in the future as CATV systems are upgraded with fiber-optic technology. This network technology is only applicable to the controller data, and cannot handle the CCTV data load.

Many jurisdictions will already have some form of communications network in place for the centralized control of intersection controllers. The architecture will allow the continued use of these networks if desired, with the lower-level twisted-pair links used for the intersection controller data. The addition of CCTV cameras brings the data rate requirement of the network up so that a high-speed network backbone is required. Concentrators can be placed in the network to multiplex the intersection controller links onto the high-speed backbone network, along with the CCTV data links.

#### ***7.5.2.4 Localized Use of Internet***

The Internet could also potentially provide data communications, but there are security issues in its use for many of the ITS network applications.

The Internet is a collection of networks using TCP/IP protocol (Transmission Control Protocol--TCP, and the Internet Protocol--IP). Since its introduction by the Inter Networking Working Group in 1982, it has gained tremendous attention in the network communities. (The average time between new networks connecting to the Internet was ten minutes as early as July, 1993.)

In this section, we investigate the feasibility of using Internet as a communication network between the TMC and other transportation fixed entities like PS's and FMC's. In particular, we focus on the average access delay and gather packet loss statistics from the Internet.

##### **7.5.2.4.1 Approach**

The PING command was used to investigate round-trip propagation times over the Internet by sending Internet Control Message Protocol (ICMP) echo-request packets. Two series of measurements were performed, one in the LA area in February-March 1994, and a new one in the Boston area in February 1995.

The results from the LA measurements were found to be lacking since they corresponded only to periodic samples of the Internet delay, instead of registering its behavior over time (important if one wants to detect worst-case conditions). Therefore the analysis here will focus mainly on the most recent results obtained in the Boston area.

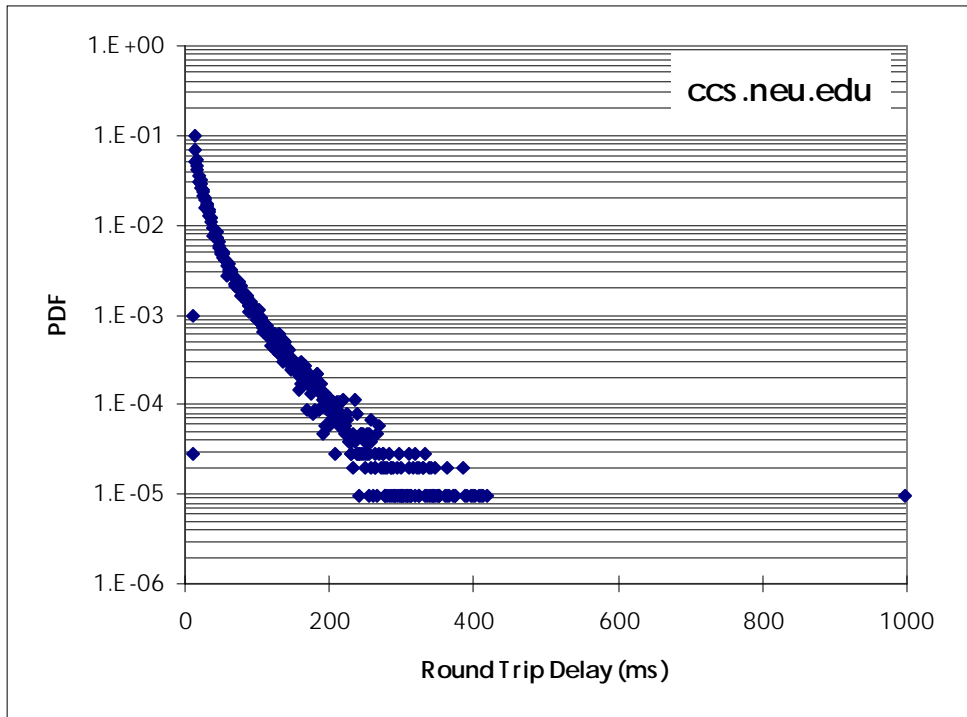
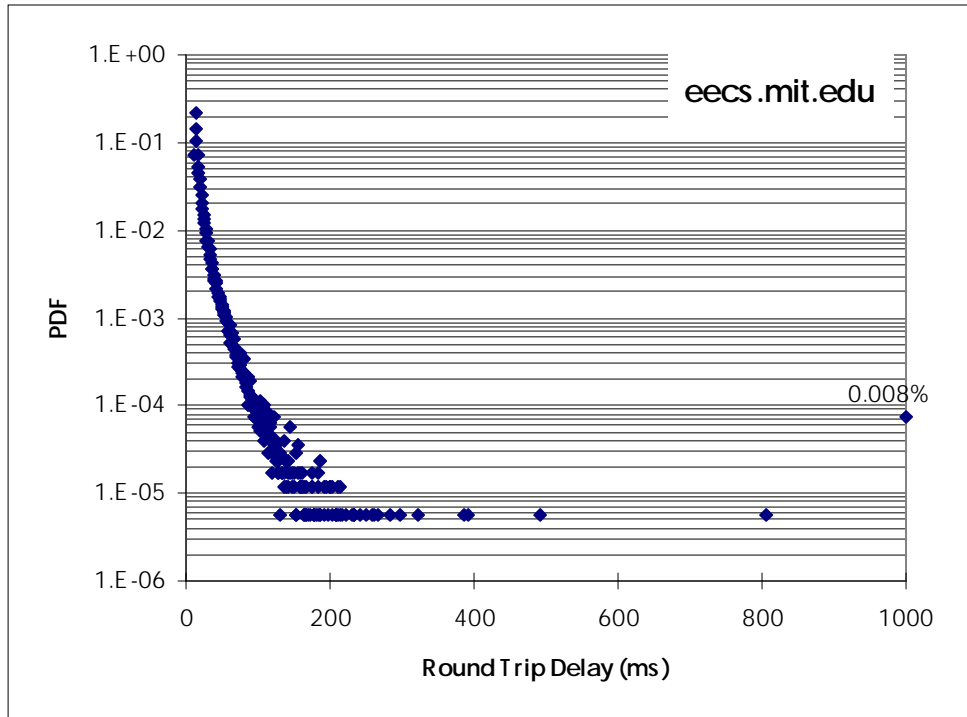
##### **7.5.2.4.2 Internet Round-Trip Measurements**

A set of seven Universities in the great Boston area, were PING'ed first for a period of 48 hours, and then for a whole week to collect round-trip information. Also selected was a small Boston organization, City Year, selected at random to "represent" organizations that in principle cannot afford, or cannot justify having dedicated high speed connections, and Digital Equipment Corporation, because although local it is located far from GTE Laboratories, and is expected to have high traffic.

Probability Density Functions (PDF's) of the observed round-trip delay were computed. All of them show considerable tails that extend to 200-400 ms, with occasional round-trip delays exceeding one second. Figure 7-5-37 shows three examples.

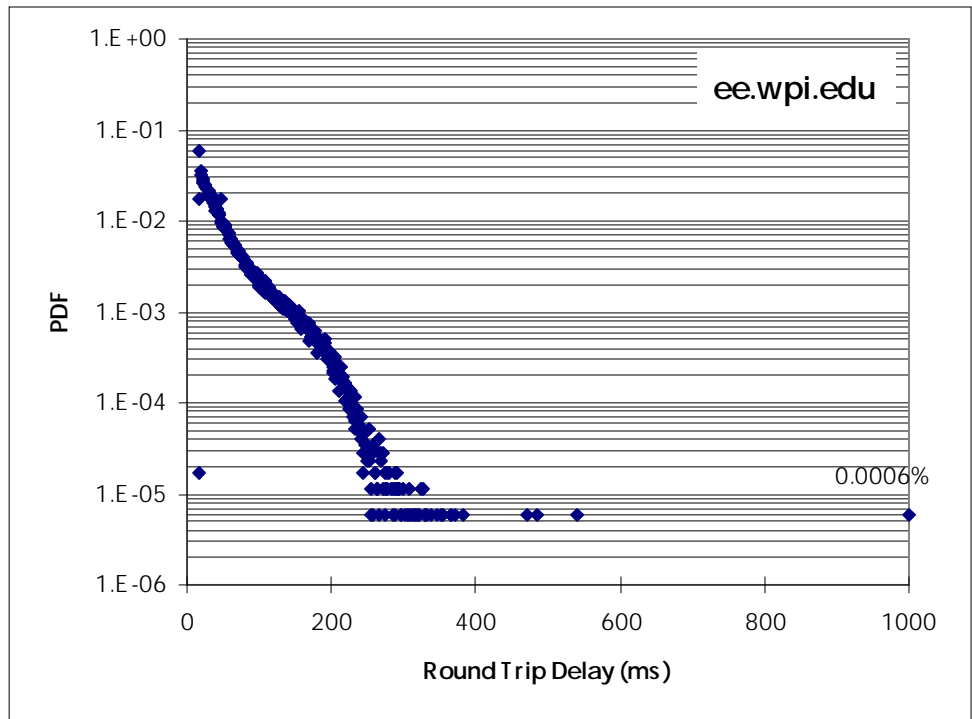
The worst PDF (i.e., highest average delay) will be used in Section 8 in the end-to-end delay simulation to arrive at the delay distribution for the traffic that crosses the Internet. The round-trip delay will be evenly split between the reverse and forward directions.





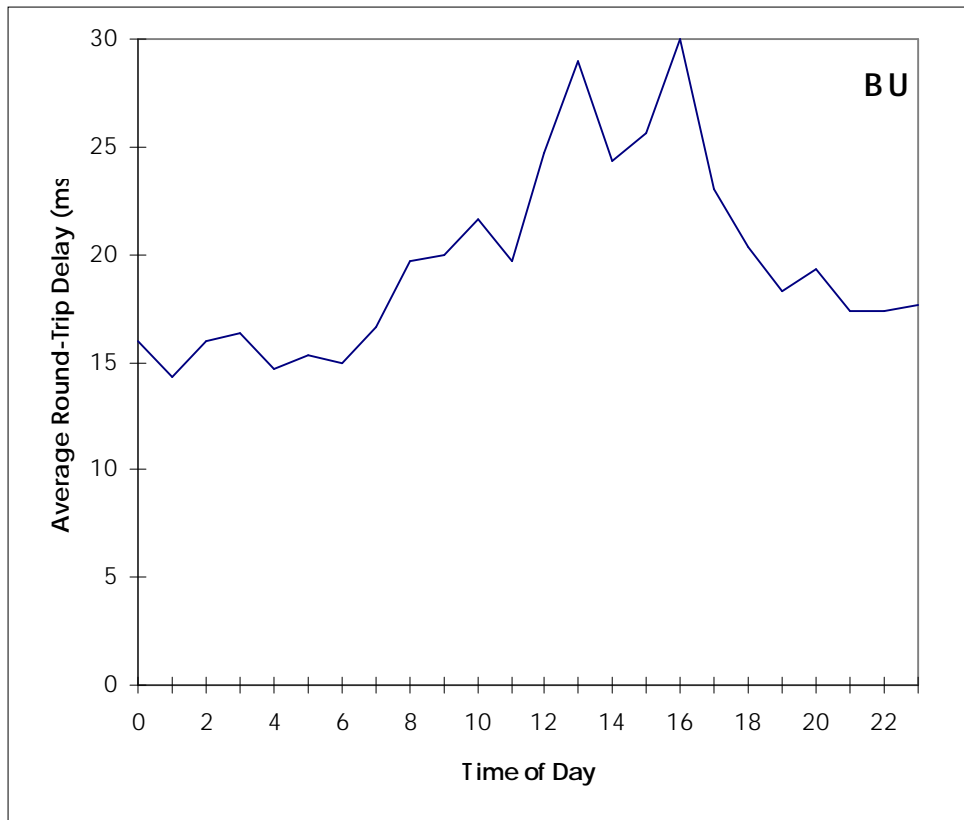
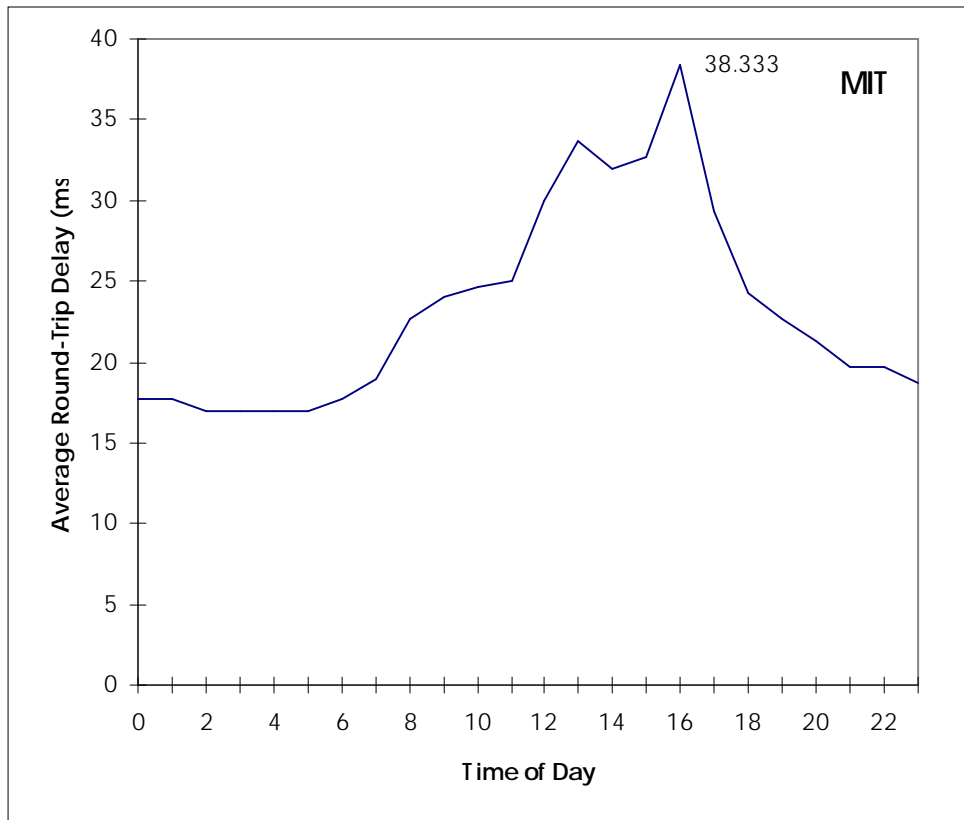
**Figure 7.5-37 PDF's of the Round-Trip Delay**

(Node not available 19 hours out of the 48 hours observation period)

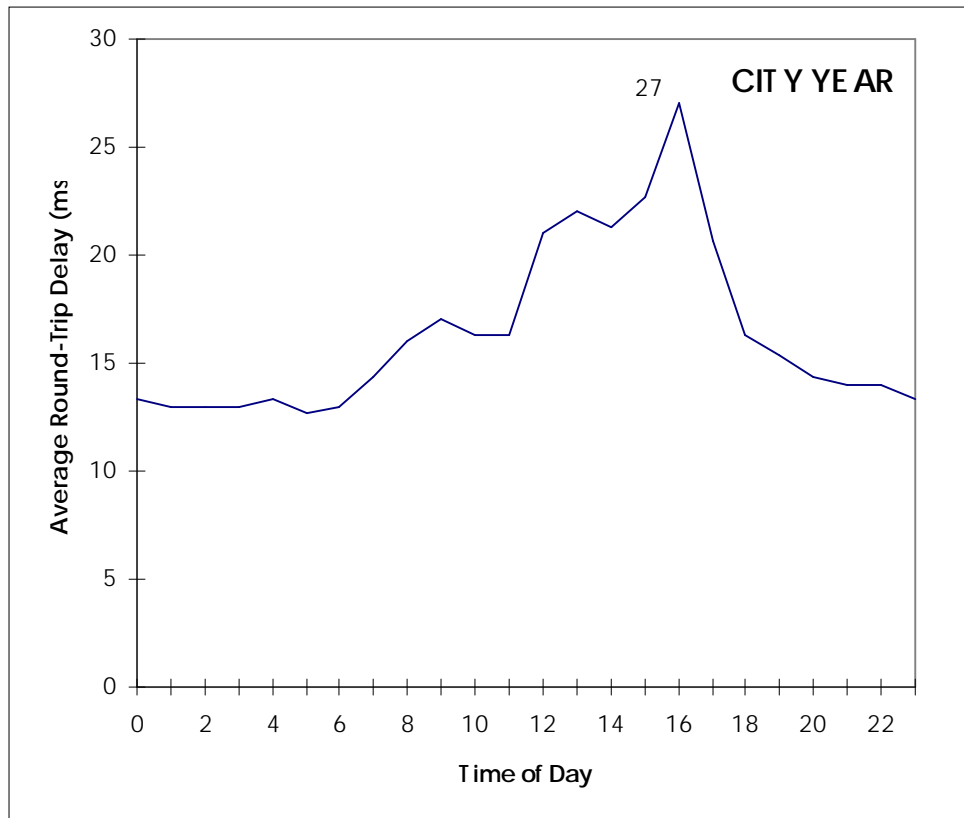
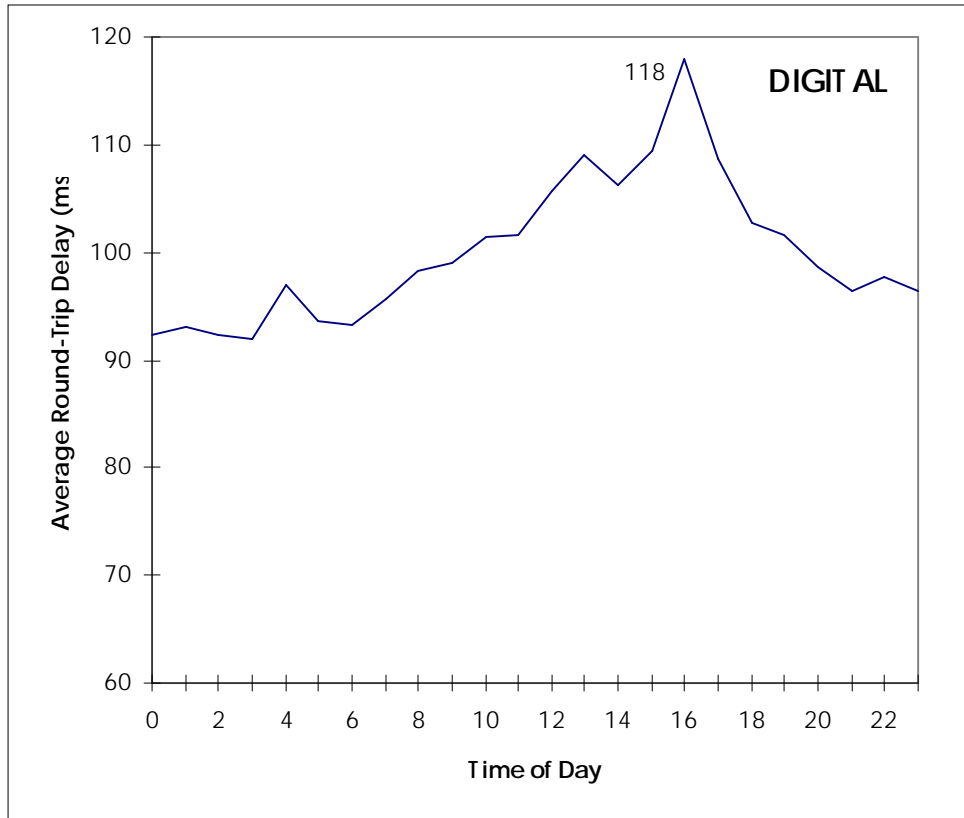


**Figure 7.5-37 PDF's of the Round-Trip Delay (Cont.)**

The average round-trip delay as a function of the time of day is shown in Figure 7.5-38. As expected, from GTE Laboratories to these Internet sites, two peaks are observed corresponding to the peak periods noticed in the E-mail and Internet Access characterizations: higher loads correspond to more congestion at the intermediate routers, and thus higher delays.



**Figure 7.5-38 Average Round-Trip Delay (Period March 5-7, 1996)**



**Figure 7.5-38 Average Round-Trip Delay (Period March 5-7, 1996) (Cont.)**

Also instructive is the delay range. From Figure 7.5-39, it is observed that while the minimum delay stays more or less the same, the maximum hourly delay suffers large increases during the peak periods. (Long delays occur also outside these periods, but since they do not affect the average delay they must be sporadic and of short duration.)

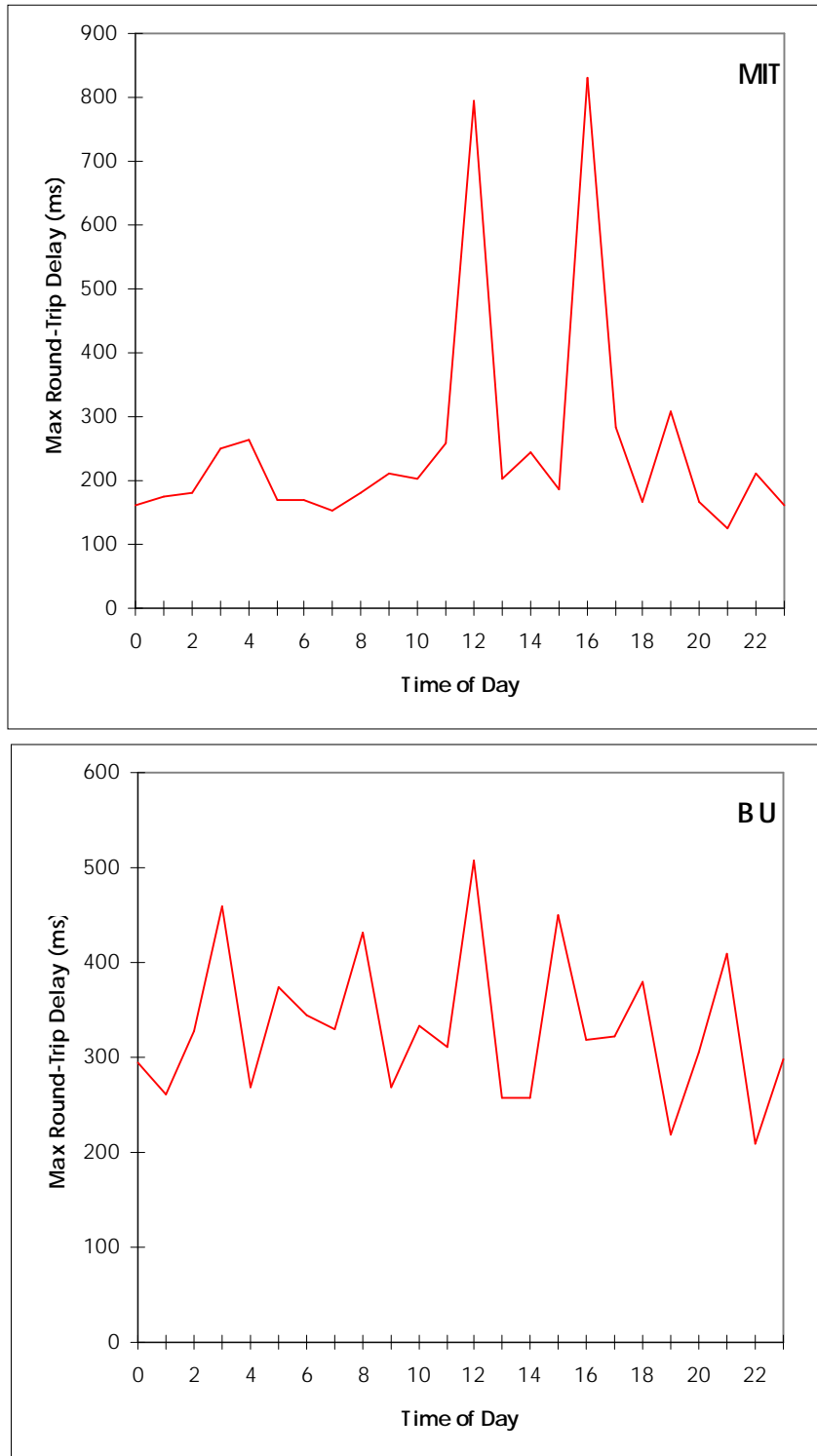
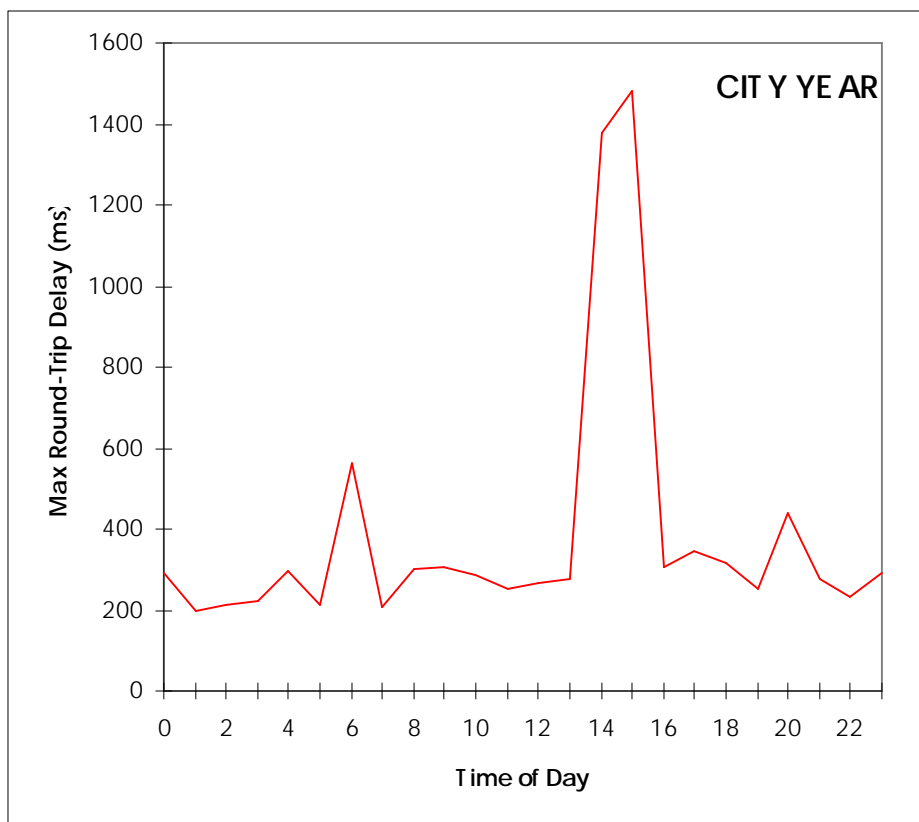
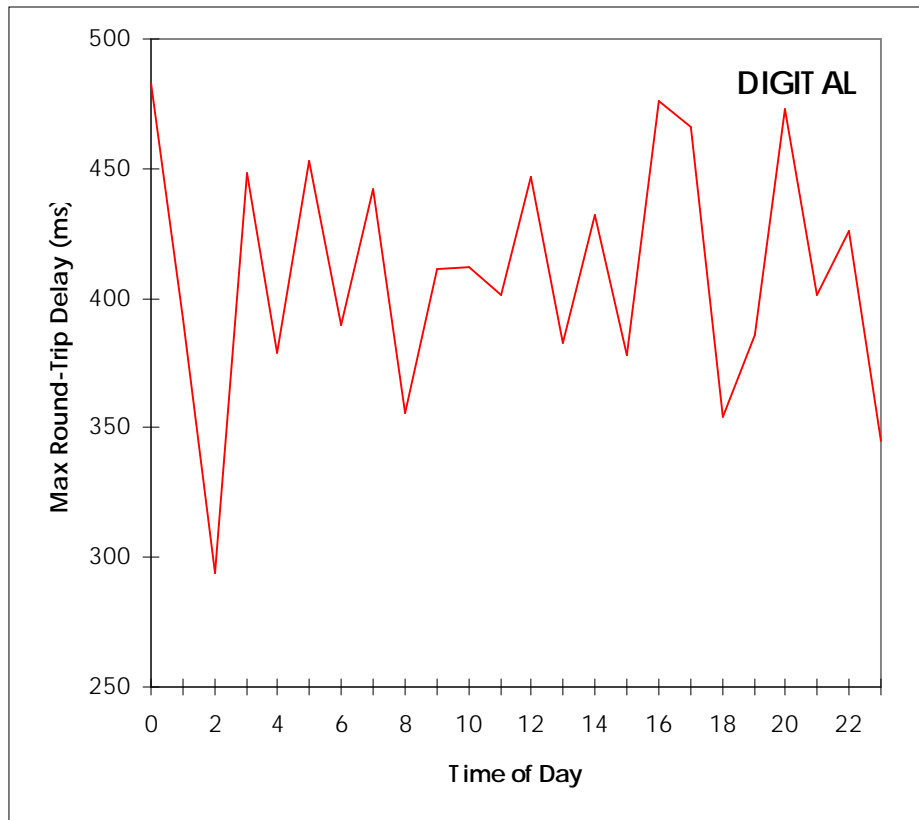


Figure 7.5-39 Example of the Range of Round-Trip Delays (Boston, March 5-7, 1996)



**Figure 7.5-39 Example of the Range of Round-Trip Delays (Boston, March 5-7, 1996) (Cont'd)**

### 7.5.2.4.3 Packet Loss

Equally important, from the point of view of information delivery, is packet loss. The co-operative workings of the Internet subject each packet to the perspective of being dropped at each router if the load exceeds the queues or the processing capabilities of the router (many are not dedicated routers).

During the same period March 5-7, 1996, information was collected on packet loss for the same organizations as above. The samples are shown in Figure 7.5-40. The conclusion is that the packet loss peaks in general with the round-trip delay.

The higher loads in the network imply higher loads in the routers, more difficult routing, and more likely overload of the routers. When overloaded, the routers implement a non-discriminating rejection of incoming packets to keep their load within reason, and not overflow.

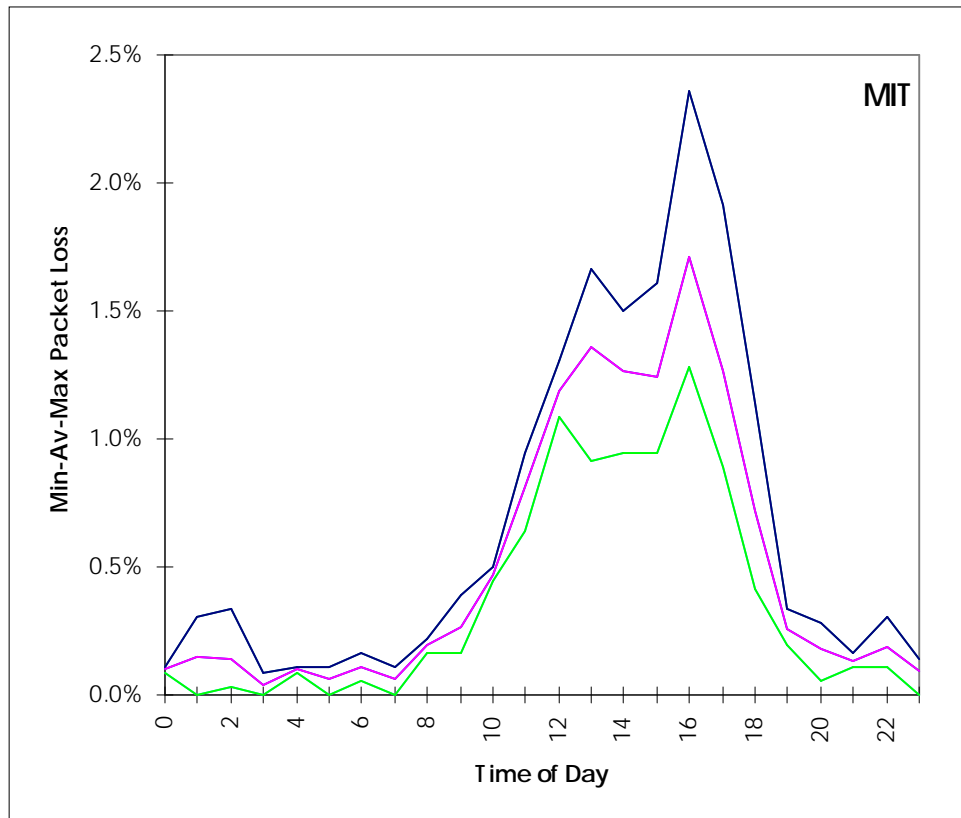
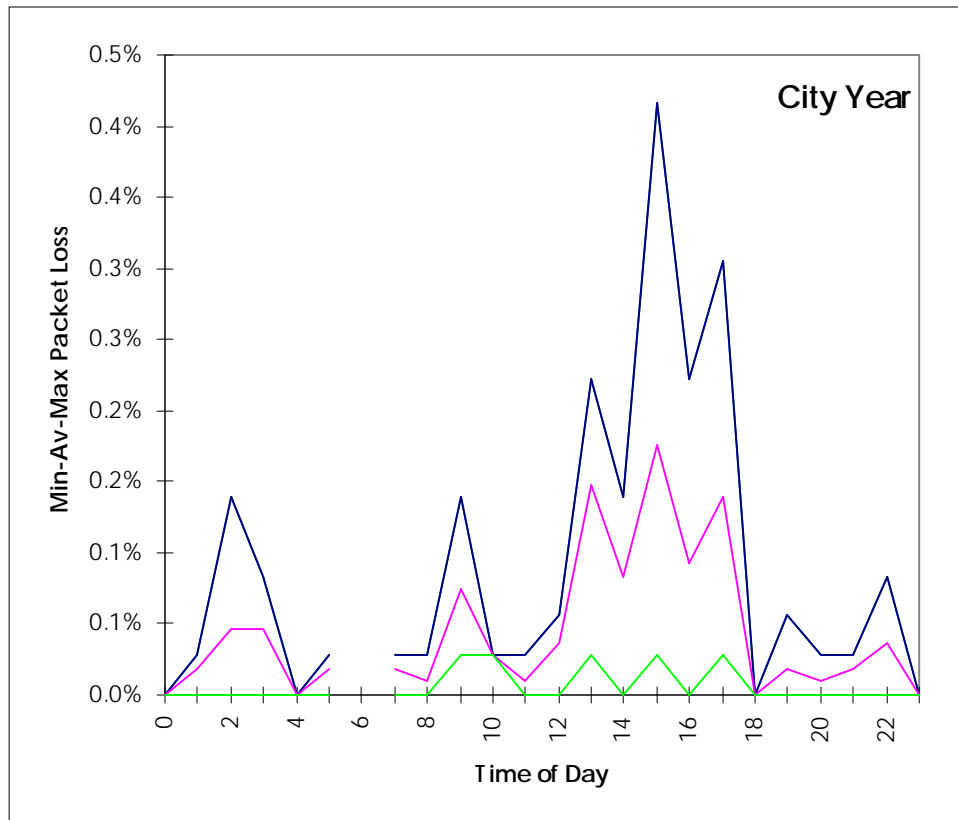


Figure 7.5-40 Minimum-Average-Maximum Packet Loss (Boston, March 5-7, 1996)



**Figure 7.5-40 Minimum-Average-Maximum Packet Loss (Boston, March 5-7, 1996) (Cont'd)**

#### 7.5.2.4.4 Conclusions

Besides the privacy and security issues of communicating over the Internet, which are still far from resolved, the stochastic nature of the traffic on the Internet must be considered. The variance of the round-trip delay, as well as its average and the percentage of packet loss vary significantly over time. Thus, all those ITS applications requiring timely, consistent delivery of information should not use the Internet as a means of transferring information.

The occurrence of packet losses points also to the need of using a guaranteed delivery protocol like TCP, and restrict the use of non-guaranteed delivery protocols (like UDP) to non-essential, mostly repetitive transactions (e.g., vehicle location, and normal, i.e., non-emergency, vehicle status reports).



## 7.6 Technology Survey and Assessment Summary

Section 7.5 presented a very broad survey and assessment of the telecommunications technologies applicable to the ITS Architecture. The key differentiating features of these technologies are summarized in this section, as a quick reference for the convenience for the reader. Table 7.6-1 provides an easy to read compilation of the terms and definitions used in the summary (and earlier in Section 7.5). Table 7.6-2 provides the summary comparison for terrestrial wireless data systems. Table 7.6-3 provides the summary comparison for satellite systems. A fraction of the table entries contain a “?” indicating the unavailability of information at the time of writing this proprietary information. It should be kept in mind that advanced technology evolves rapidly, so the information in the tables will need to be kept up to date in the future.

**Table 7.6-1 Definition of the Entries in the Summary Tables**

<b>TERM</b>	<b>DESCRIPTION</b>
<b>SATELLITE SYSTEMS</b>	Name of the satellite system
<b>PARTNERSHIP</b>	List of the companies, organizations, or individuals who are the principals and/or contributors of capital
<b>SPECIFIC CHARACTERISTICS</b>	
<b>ORBIT CLASS</b>	<p><b>Classification of the satellite orbit</b></p> <p><b>LEO</b> - Low Earth Orbit. Altitude is typically below 10,000 km.</p> <p><b>Big LEO</b> - The term "Big" refers to the fact that the system is designed for voice and data services. The operating frequency is above 1 GHz.</p> <p><b>Little LEO</b> - Little LEO's operate below 1 GHz, typically in the VHF band. Designed for data services only.</p> <p><b>GEO</b> - Geosynchronous Earth Orbit. Altitude is approximately 36,000 km. Geostationary satellites having this orbit remain stationary over the same earth location.</p> <p><b>HEO</b> - Highly Elliptical Orbit. Orbit has large eccentricity (continuously changing altitude)</p> <p><b>MEO</b> - Medium Earth Orbit. Altitudes ranging from 3,000 km to 20,000 km.</p> <p><b>ICO</b> - Intermediate Circular Orbit, as termed by the European satellite community. Same as MEO.</p>
<b>ALTITUDE (km)</b>	Orbital altitude in kilometers over the surface of the earth.
<b>NUMBER OF SATELLITES</b>	Total number of satellites in the specified satellite system.
<b>NUMBER OF PLANES</b>	Number of planes used in the satellite system
<b>ORBITAL PERIOD (minutes)</b>	Orbital period in minutes
<b>AVERAGE SATELLITE VISIBILITY TIME (minutes)</b>	Average time that a satellite is visible to the user's communication equipment on earth in minutes.
<b>MULTIPLE SATELLITE VISIBILITY</b>	<p><b>yes</b> - indicates that more than one satellite is visible to the user's communication equipment on earth.</p> <p><b>no</b> - indicates that only one satellites is visible to the user's communication equipment on earth.</p>
<b>SATELLITE DIVERSITY</b>	<p><b>yes</b> - indicates that signals (carrying identical information) from two or more satellites are combined using a technique so as to improve reception for the land user.</p> <p><b>no</b> - indicates that satellite diversity is not used.</p>
<b>MULTIPLE ACCESS TECHNIQUE</b>	<p>Schemes used to provide multiple users access to the network in order to minimize transmission overhead and maximize overall throughput.</p> <p><b>Fixed-assignment channel-access:</b></p> <p><b>CDMA</b> - Code Division Multiple Access.</p> <p><b>DS-SS</b> - Direct Sequence Spread Spectrum</p> <p><b>FDMA</b> - Frequency Division Multiple Access.</p> <p><b>FH-SS</b> - Frequency Hopped Spread Spectrum</p> <p><b>SDMA</b> - Spatial Division Multiple Access.</p>

TERM	DESCRIPTION
	<p><b>TDMA</b> - Time Division Multiple Access.  <b>TDD</b> - Time Division Duplexing (a form of TDMA)  <b>Multiplexing technique:</b>  <b>FDM</b> - Frequency Division Multiplexing  <b>TDM</b> - Time Division Multiplexing  <b>Random-Access Methods:</b>  <b>Dynamic Slotted ALOHA protocol</b>  <b>DSMA/CD</b> - Digital Sense Multiple Access/ Collision Detection  <b>Data Sense Multiple Access</b></p>
MODULATION	<p><b>BPSK or PSK</b> - Binary Phase Shift Keying  <b>QFSK or 4-ary FSK</b>- Frequency Shift Keying with four orthogonal signals  <b>GMSK</b> - Gaussian Filtered Minimum Shift Keying  <b>QPSK</b> - Quadrature Phase Shift Keying  <b>O-QPSK</b> - Offset Quadrature Phase Shift Keying</p>
FREQUENCY BAND	<p><b>VHF</b> - Very High Frequency, 30 to 300 MHz  <b>UHF</b> - Ultra High Frequency, 300 to 3000 MHz  <b>SHF</b> - Super High Frequency, 3 to 30 GHz  <b>L-band</b> - 390 MHz to 1.55 GHz  <b>S-band</b> - 1.55 GHz to 5.2 GHz  <b>Ka-band</b> - 33 GHz to 36 GHz  <b>SMR band</b> - 896-901 MHz, 935- 940 MHz  <b>Cellular band</b> - 824-849 MHz, 869-894 MHz  <b>ISM</b> - 902-928 MHz  <b>Narrowband PCS</b> – 901 to 902 Mhz, 930 to 931MHz, 940- to 941MHz  <b>Paging</b> - 929-932 MHz</p>
UPLINK FREQUENCY BAND	Allocated frequency band for transmission use from the earth user to the satellite.
DOWNLINK FREQ. BAND	Allocated frequency band for transmission use from the satellite to the earth user
DELAY CHARACTERISTICS	
Minimum mobile link one-way propagation time (ms)	Minimum one-way propagation time between mobile user and satellite in milliseconds.
Maximum mobile link one-way propagation time (ms)	Maximum one-way propagation time between mobile user and satellite in milliseconds.
SATELLITE ON-BOARD PROCESSING	<p><b>no</b> - indicates a "bent-pipe" or transparent transponder  <b>yes</b> - indicates on-board signal regeneration before retransmission</p>
HAND-OFF	<p><b>no</b> - indicates that a terminal's call within one cell area or satellite can not be handed off to another cell or satellite as the terminal moves into this new area.  <b>yes</b> - indicates that a terminal's call can be handed off to an adjacent cell or satellite</p>
VOICE CIRCUITS PER SATELLITE	Number of voice channels that a satellite can accommodate
COVERAGE	Geographic region in which service is provided by the system
<b>MATURITY/ FEASIBILITY</b>	
SCHEDULED OPERATION	Estimated date of initial service of system
PERCENTAGE OF OBTAINED FINANCE	Estimated percentage of obtained finance for the system
FCC LICENSE	<b>Date</b> indicates the estimation of when the system obtained an FCC license.
<b>CAPABILITIES</b>	
VOICE RATE (kbps)	Bit rate of digitized voice in kilobits per second.
DATA RATE(kbps)	Bit rate of data information. Units given in kilobits per second.
MOBILITY	
DUAL-MODE versus SINGLE MODE USER TERMINALS (land and satellite)	<p><b>Dual</b> - indicates that the terminal provides operating modes for both satellite and terrestrial communications.  <b>Single</b> - indicates that the terminal provides only one operating mode.</p>
HAND-HELD versus PORTABLE USER TERMINALS	<b>Portable</b> - indicates that the user terminal is a briefcase- or bag-sized self-contained unit combining antenna, battery,

<b>TERM</b>	<b>DESCRIPTION</b>
	transceiver and handset. <b>Hand-Held</b> - indicates that the user terminal is sized to a human's palm.
<b>SYSTEM SECURITY</b>	<b>Confidential Service</b> - a service for which the content of the user's data, traffic volumes and identities is kept confidential or private. This service prevents unwarranted extraction of information from the communication channel. <b>Authentication Service</b> - a service which ensures that the content of the user's data and any other information is genuine, unaltered, and complete. This service also ensures that the information is not an unlawful replay of information. This service prevents someone from injecting false data into the communication channel. <b>Encryption</b> - security mechanism which converts plaintext into cyphertext. Cyphertext is unintelligible except to those individuals/systems that know the secret of the decryption algorithm. An encryption service enables both confidential and authentication services.
<b>COSTS</b>	
SYSTEM (Million US Dollars)	Estimated cost of the full deployment of the system in Millions of US Dollars.
USER TERMINAL (US Dollars)	Estimated cost of the terminal in US Dollars.
VOICE RATE (US Dollars per minute)	Estimated cost of voice service in US Dollars per minute.
DATA RATE (US Dollars per kbyte)	Estimated cost of data service in US Dollars per kilobyte.
<b>SERVICES</b>	List of services made available by the system.
<b>TARGETED APPLICATIONS</b>	Applications for which the system was designed.

**Table 7.6-2 Summary Comparison of Wireless MAN and Cell-based Land Mobile Systems**

	RAM Mobile Data USA	ARDIS	GEOTEK	CDPD	"CDPDng"	SKYTEL	METRICOM	TAL
<b>PARTNERSHIPS</b>	RAM Broadcasting Corporation, BellSouth (originally developed by Ericsson and Swedish Telecom)	Motorola and IBM	Geotek	CDPD Forum (150 companies including cellular service providers, equipment manufacturers, software developers)	CDMA Data Group	Mobile Telecommunications Technology, Inc.	Metricom	Tetherless Access LTD.
<b>System Characteristics</b>								
<b>COMMUNICATIONS TECHNOLOGY</b>	SMR	SMR	ESMR	Cellular	Cellular	2-way paging	MAN	?
<b>SWITCHING</b>	packet	packet	packet	packet and circuit	packet and circuit	n/a	packet	
<b>OPEN STANDARD</b>	Although promoted as an open architecture and a defacto standard, uses proprietary network layer protocol called MPAK.	proprietary	proprietary	yes	yes	proprietary (Motorola's ReFLEX 500 protocol)	proprietary	proprietary ?
<b>RADIO CHANNEL ACCESS TECHNIQUE</b>	proprietary, TDMA	proprietary, FDMA	proprietary, FHSS	Open, FDMA (packet radio overlay on AMPS)	will be open, (packet radio overlay on CDMA)	proprietary	proprietary, FHSS	proprietary, CDMA ?
<b>MULTI-USER ACCESS TECHNIQUE</b>	Data Sense Multiple Access	Dynamic-Slotted ALOHA	?	Broadcast in Forward direction; Digital-Sense Multiple Access/Collision Detection (DSMA/CM) in Reverse direction (packet radio overlay on AMPS)	CDMA-SS	?	?	?
<b>MODULATION</b>	GMSK	4-ary FSK	?	GMSK	?	BPSK/QPSK	wide ?	?
<b>BANDWIDTH</b>	12.5 kHz	25 kHz	?	30 kHz	?	25 kHz	wide ?	?
<b>FREQUENCY BAND</b>	SMR	SMR	ESMR	Cellular	Cellular	Narrowband PCS	ISM	?
<b>LICENSED SPECTRUM</b>	yes	yes	yes	yes	yes	yes	no	no
<b>NETWORK ARCHITECTURE</b>	macro cellular	macro cellular	macro cellular	cellular	cellular	macro cellular	micro cellular with no handoffs, multihop	micro cellular, multihop
<b>MOBILITY</b>	vehicle speeds	vehicle speeds	??	highway speeds	highway speeds	low vehicle speeds	pedestrian speeds	pedestrian speeds
<b>SYSTEM SECURITY</b>	no (user provided encryption)	no (user provided encryption)	Medium (use of spread spectrum)	high (encryption algorithms)	high (encryption algorithms)	no (user provided encryption)	Medium (use of spread spectrum)	??
<b>MATURITY OF SYSTEM</b>	mature	mature	new	mature	future	new	new	?
<b>SERVICES</b>								
<b>IP TRANSPORT</b>	no	no	future	yes	yes	n/a	yes	yes
<b>IP TRANSPARENCY (use of gateways)</b>	yes	yes	future	yes	yes	n/a	no	?

**Table 7.6-3 Summary Comparison of Proposed Satellite Systems**

<b>SATELLITE SYSTEMS</b>	<b>ORBCOMM</b>	<b>STARSYS</b>	<b>VITASAT</b>	<b>CONSTELLATION (formerly ARIES)</b>	<b>GLOBALSTAR</b>	<b>IRIDIUM</b>	<b>TELEDESIC</b>	<b>ELLIPSO</b>	<b>ICO (formerly Inmarsat-P)</b>	<b>ODYSSEY</b>	<b>INMARSAT (A,B,C,M)</b>	<b>MSAT</b>	<b>SKYCELL</b>
<b>PARTNERSHIP</b>	Orbital Sciences Corp., Teleglobe, TRW	North America Collection and Location by Satellite (NACLS), ST System	Volunteers In Technical Assistance (VITA, VITACOMM)	Constellation Communication  Joint venture with TELEBRAS for the equatorial plane (ECCO)	Loral, Qualcomm	Motorola	Bill Gates of Microsoft, and Craig McCaw founder of McCaw Cellular Communications, Inc. and chairman of Teledesic	Ellipso	Multiple Government Agencies, Hughes	Teleglobe, TRW	Multiple Government Agencies (International Maritime Satellite Organization, consortium of 60 countries)	American Mobile Satellite Corp., Gentel, Inc., BCE, Spar Aerospace, Hughes, Mitsubishi, Westinghouse	American Mobile Satellite Corp. (Hughes, AT&T, MTel, Singapore Telecom)
<b>Specific Characteristics</b>													
ORBIT CLASS	Little LEO	Little LEO	Little LEO	Big LEO	Big LEO	Big LEO	Big LEO	MEO and HEO	MEO (Intermediate Circular Orbits, ICO)	MEO	GEO	GEO	GEO
ALTITUDE (km)	775, 950-1150 depending on reference	1288	800	1018	1400	780	695-705	MEO is 8040; HEO is 7846x520	10355	10354	35786	35786	35786
NUMBER OF SATELLITES	20, 26, 36 depending on reference	24	2 to 3	48	48 plus 8 spare	66 plus 6 spare	840 plus up to 84 spare	MEO is 6; HEO is 10	10 plus 3 spare	12 plus 3 spare	Inmarsat phase 2 uses 4 satellites (since 1992) Inmarsat phase 3 uses 5 satellites (projected 1996)	2	?
NUMBER OF PLANES	3	?	?	4	8	6	21	2	2	3	?	?	?
ORBITAL PERIOD (minutes)	104.1-108.3	?	?	105	114	100	99	MEO is 280; HEO is 180	359	360	N/A	N/A	N/A
AVERAGE SATELLITE VISIBILITY TIME (minutes)	95% of time	?	?	?	8.21	5.54	1.74	?	57.8	47.27	always	always	always
DUAL SATELLITE VISIBILITY	?	?	?	?	3 or more	at poles	>= 2 most of the time	>= 2 North of 40° South	usually >= 2	>= 2	?	?	?
SATELLITE DIVERSITY	?	?	?	?	yes	no	no	yes	yes	no	?	?	?
MULTIPLE ACCESS TECHNIQUE	?	?	?	CDMA	CDMA	FDMA/ TDMA/ TDD	TDMA, SDMA, FDMA, Advanced TDMA	CDMA	TDMA	CDMA	mostly FDMA	TDMA/TDD	FDMA
MODULATION	PSK	?	?	?	QPSK	QPSK	?	C-QPSK	QPSK	QPSK	?	?	?
JPLINK FREQUENCY BAND	VHF	?	?	L-band	L-band	L-band	Ka-band	L-band	S-band	L-band	?	L-band	L-band
DOWNLINK FREQ. BAND	VHF	?	?	S-band	S-band	L-band	Ka-band	S-band	S-band	S-band	?	L-band	L-band
Delay Characteristics													
Minimum mobile link one-way	?	?	?	3.39	4.63	2.6	2.32	?	34.5	34.6	238	238	238

**Table 7.6-3 Summary Comparison of Proposed Satellite Systems**

<b>SATELLITE SYSTEMS</b>	<b>ORBCOMM</b>	<b>STARSYS</b>	<b>VITASAT</b>	<b>CONSTELLATION (formerly ARIES)</b>	<b>GLOBALSTAR</b>	<b>IRIDIUM</b>	<b>TELEDESIC</b>	<b>ELLIPSO</b>	<b>ICO (formerly Inmarsat-P)</b>	<b>ODYSSEY</b>	<b>INMARSAT (A,B,C,M)</b>	<b>MSAT</b>	<b>SKYCELL</b>
propagation time (ms)													
Maximum mobile link one-way propagation time (ms)	5 sec	?	?	?	11.5	8.2	3.4	38.7	48	44.3	275	?	?
SATELLITE ON-BOARD PROCESSING	?	?	?	?	no	yes	yes	?	?	no	no	no	no
HAND-OFF	?	?	?	?	yes	yes	yes	yes, terminal not involved	yes	yes	?	?	?
VOICE CIRCUITS PER SATELLITE	?	?	?	?	2000-3000	1100 (power limited)	100,000 (16 kbps channels)	?	4500	2300	?	?	?
COVERAGE	US now, Global future	Global	Global, designed for developing countries including South America, Africa	Global	within +/- 70° latitude	Global	Global, except for 2° hole at poles; 95% of earth's surface	North of 50° South	Global	major land masses	Global	North America, Hawaii, Caribbean	North America
<b>MATURITY/ FEASIBILITY</b>													
SCHEDULED OPERATION	Currently Operational in US; 1996 Canada and Mexico; 1997 Europe and Latin America	1996	1996	1998	1998	1998	2001	1998	2000	2000	Operational since 1993	1996	?
PERCENTAGE OF FINANCE OBTAINED THUS FAR	~100%	?	?	~15%	~70%	~30%	?	?	58%	?	?	?	?
FCC LICENSE	late 1994	Experimental License in 1992	?	?	Jan. 1995	?	?	?	?	?	WARC '92 and WRC '95	?	1989
<b>CAPABILITIES</b>													
VOICE RATE (kbps)	?	?	?	4.8	adaptive 2.4/4.8/9.6	2.4/4.8	16	4.15	4.8	4.8	6.4 to 16 depending on system	?	?
DATA RATE(kbps)	2.4 uplink, 4.8 downlink	?	?	2.4	7.2 sustained throughput	2.4	16 to 2048	0.3 to 9.6	2.4	9.6	0.6, 2.4, 9.6, 64 depending on system	2.4	1.2-4.8
MOBILITY	?	?	?	?	?	?	Fixed	?	?	?	Fixed and Mobile	Fixed (Canada and Alaska); Mobile (Contiguous 48 States)	Full mobility (vehicles, ships, and airplanes)
DUAL-MODE vs. SINGLE MODE USER TERMINALS (land and satellite)	?	?	?	?	DUAL	DUAL	SINGLE	DUAL	DUAL	DUAL	DUAL (drivers for ARDIS, CDPD, GSM)	DUAL	?
HAND-HELD vs. PORTABLE USER TERMINALS	Portable and Hand-held	?	Portable	Hand-held	Hand-held	Hand-held	Portable	Hand-held	Hand-held	Hand-held	Portable	Portable	Portable

**Table 7.6-3 Summary Comparison of Proposed Satellite Systems**

<b>SATELLITE SYSTEMS</b>	<b>ORBCOMM</b>	<b>STARSYS</b>	<b>VITASAT</b>	<b>CONSTELLATION (formerly ARIES)</b>	<b>GLOBALSTAR</b>	<b>IRIDIUM</b>	<b>TELEDESIC</b>	<b>ELLIPSO</b>	<b>ICO (formerly Inmarsat-P)</b>	<b>ODYSSEY</b>	<b>INMARSAT (A,B,C,M)</b>	<b>MSAT</b>	<b>SKYCELL</b>
<b>SYSTEM SECURITY</b>	?	?	?	?	?	?	encryption	?	?	?	?	?	authentication only
<b>COSTS</b>													
SYSTEM (Million J.S. Dollars)	?	?	?	\$1,700	\$2,000	\$3,700	\$9,000	\$750	\$2,600	\$1,800	?	?	?
JSER TERMINAL	\$100-\$400	?	\$3500	?	\$750/terminal; \$1000-\$1200 for telephone	\$2500-\$3000	?	~\$1000; \$300 add-on to digital cellular unit	"Several Hundred"	~\$300	\$5000-\$35,000 depending on system	\$5000-\$6000	?
VOICE RATE (US Dollars per minute)	?	?	?	?	\$0.35-\$0.55	\$3.00	?	\$0.50	\$1-\$2	\$0.75 ; \$24 monthly charge	\$2.00-\$8.00 depending on system	\$2.50	Standard, \$25/month, \$1.49/minute Business, \$175/month 200 minutes free, \$0.85/minute voice, data, fax
DATA RATE (US Dollars per kbyte)	\$1.00 per 100 bytes	?	\$50/month for up to 100 kbytes	?	?	?	?	?	?	?	\$1.00-\$1.50	?	similar to voice service costs
<b>SERVICES</b>	two-way messaging, RDSS	one-way data, two-way messaging	two-way messaging; store and forward with typically 90 minute message delay and as much as 12 hour delay.	voice, data, fax	Voice, data, fax, paging, short message service, RDSS	Voice, data, fax, paging, messaging, RDSS	Voice, data, fax, paging, video	Voice, data, fax, paging, messaging, RDSS	Voice, data, fax, paging	Voice, data, fax, paging, messaging, radio determination satellite services (RDSS)	voice, data, fax, e-mail, store-and-forward, alerting, position determination	voice, data, fax, dispatch radio	Voice, data, fax, location determination
<b>TARGETED APPLICATIONS</b>	emergency comm., 2 way-mail, remote resource monitoring	emergency comm. stolen asset recovery, hazardous material tracking	Store-and-forward data	extension of the cellular network	worldwide communication	worldwide communication	ISDN to rural businesses and remote terminals (fixed)	extension of cellular network	global phone through integration with cellular services	extension of cellular network	worldwide communication	mobile office, position determination, e-mail, monitoring, voice dispatching (2-way), broadcast and multicast messaging	transportation, maritime, aeronautical remote site industries

## 8. COMMUNICATION SYSTEMS PERFORMANCE – A CASE STUDY

This section presents an important thrust in the ITS Architecture development effort. The use of existing (i.e., commercially available) and emerging telecommunication infrastructures is integral to the ITS Architecture and corner stone to its feasibility. In this section detailed, in-depth analyses and simulations are performed to support this architecture development philosophy. Through the results of the simulations in a specific case study, it will be demonstrated that the ITS data loads, particularly for wide area communications, can be handled by existing, i.e., commercially deployed and available systems.

For wide area communications in particular, the ITS Architecture leverages the communication infrastructures put in place by the very broad telecommunication industry (see Sections 3 and 7 for the technologies applicable to the myriad ITS data flows). Correspondingly, the evaluation strategy in this section utilizes the expertise that has been developed in the telecommunications industry in planning, deploying and operating these infrastructures. More specifically, the evaluation uses and builds upon simulation tools that have been developed for real systems, i.e., which have been and continue to be deployed commercially. The simulation tools and various of their results have been validated over time by a cross-section of leading industry partners. These partners include GTE, AT&T/McCaw, Bell Atlantic, NYNEX, and others in the CDPD Forum for Cellular Digital Packet Data (CDPD), and Qualcomm, GTE, Nokia, and others in the CDMA Development Group (CDG) for CDMA. In addition to the established tools, the use of existing and emerging standards (e.g., CDPD in wireless communication) simplifies the evaluation process through a structured, well accepted, and reliable definition of the key simulation parameters. This, in turn, aids the Independent Verification and Validation (IV&V) process sought by the Government.

The ITS communication systems simulation is configured into two segments – wireless and wireline – reflecting the nature of the modern communication infrastructure. Although the wireless segment typically limits performance, the performance of both segments is required for a complete and thorough characterization of the communication layer of the ITS system architecture.

Significant resources were dedicated to analyzing, simulating, and evaluating a specific wireless infrastructure that can accommodate the wide area ITS services. For practical reasons, the wireless simulation effort had to be constrained to open, already standardized systems. Thus, given that Cellular Digital Packet Data (CDPD) is the only fully standardized, open-system for data communications over cellular (in the U.S. or abroad), with the advantage of being in an advanced deployment stage, CDPD is used as a case study to show the feasibility of a wide-area ITS cellular solution. This does not imply, however, any *a priori* commitment to CDPD as *the* ITS wide-area delivery platform. Rather, it serves to demonstrate the feasibility of the architecture in that commercially available wireless systems do indeed exist that can handle the ITS data load requirements into the foreseeable future.

Meanwhile, wireline simulation is not neglected, it is used to aid in designing a candidate backbone network to provide connectivity and access to the wireless assets and to tie together the fixed transportation entities.

End-to-end communication system performance will be obtained by integrating the simulation efforts in these two areas. Performance results for the overall communication system associated with given users and/or user services will be obtained. Naturally, the end-to-end communication system performance



should be tied to the corresponding latencies identified in the *Mission Definition* document for the ITS services (whose offering involves both communication and transportation subsystems). The selection of the best communication architecture and technologies can then be pursued to meet the broad objectives of sufficiency, cost effectiveness, and risk mitigation through proper utilization of existing and emerging wireless and wireline technologies.

With the objective of promoting user acceptance for each medium, and especially for those that involve air-time charges (e.g., wireless data systems like CDPD), care is taken to utilize a message structure that minimizes user cost by reducing overhead (transmitting the required information, and not requiring unnecessary padding to fit fixed message sizes). Simultaneously, but secondarily, this approach optimizes system performance by increasing throughput for a given infrastructure, or improving performance for the same effective user load.

## **8.1 Wireless Systems Performance**

The objective of this section is to determine whether the communications element or "layer" of the system architecture is both sufficient and efficient at all stages of deployment, especially for the 1997, 2002, and 2012 time frames.

The analysis of the 2012 time frame was performed at earlier stages of the National ITS Architecture Study (Phase I), and is reported herein, even though the loads date back to the Phase II IPR2 submission (Logical and Physical Architecture data flows of August 1995). The objective of presenting these results is to show system performance with the highest ITS only loads anticipated for that time frame.

The 2002 time frame was selected for complete evaluation upon discussions with the Government and the Technical Review Team. We will analyze the performance of the CDPD system for the cases of ITS only, ITS plus Non-ITS, and ITS plus Non-ITS in case of Incident. These simulations will use worst case loads for the most recent (January 1996) Logical and Physical Architecture data flows.

### **8.1.1 Scope of Performance Analysis**

The peak period scenario to be analyzed is obtained from the actual cellular deployment for each Government chosen scenario (which we assume not to expand with time thereby implying worst case performance results). The peak voice load was computed for each sector from the Erlang-B formula for 2% blocking probability. For the ITS data load, proportionality to the voice load (i.e., to the number of cellular users) was assumed. The underlying implication is that there is a proportionality between the number of cellular voice users and the number of ITS users (i.e., the concept of a "wireless" use pattern is assumed for the lack of better information). Thus, the overall ITS data load was divided proportionally by the sectors as a function of their voice load.

CDPD performance was simulated for two of the three scenarios defined by the Government, namely Urbansville, and Thruville. Mountainville was analyzed from the point of view of cellular coverage, but CDPD was not exercised because it is very unlikely that CDPD will be deployed in Lincoln County, MT at that time, given the small population density, and the foreseeable loads. That, however, does not mean that users in those regions would be left out of data coverage. Indeed, through Circuit-Switched CDPD, everyone could piggyback on that infrastructure to exchange data wherever cellular coverage reaches.

#### **8.1.1.1 Urbansville 2002 and 2012**

In Phase I, we analyzed the case of one reserved CDPD channel plus another one dynamically assigned as a function of availability and demand. In Phase II, we considered the case of one reserved CDPD

channel without any additional dynamically assigned channels, as well as a totally dynamic solution for the CDPD problem, with no reserved channels.

#### 8.1.1.1.1 Cellular Deployment in the Detroit MSA

The CDPD deployment under consideration will be analyzed as an overlay onto the real cellular infrastructure deployed in the Detroit area (up-to-date as of November 1993). The definition of this realistic deployment required the compilation of a very large set of detailed infrastructure parameters from the FCC filings of the Detroit Cellular Telephone Company (DCTC).

The DCTC FCC filing information is summarized in Table 8.1-1. An example of base station (BS) characterization thus obtained is provided in Table 8.1-2 for DCTC Site #25. Each antenna was characterized based, whenever possible, on manufacturer provided information, and otherwise by reading from polar plots filed with the site authorization requests. An example is shown in Table 8.1-3.

The area analyzed in this case study corresponds to the total area of the three counties that make up Urbansville. In Figure 8.1-1, we schematically present the distribution of the BSs read from the FCC filings. Note that it was not possible to include the boundaries of Urbansville since they were not provided by the Government to the Teams. Figure 8.1-2 (obtained using GRANET) presents the best server map for the three counties encompassing Urbansville (in the Detroit area). The ragged boundaries of the cells reflect actual propagation conditions, thus showing how topography, topology, and land use affect conditions.

In this realistic test case, the uniformity assumption that had been used early in Phase I has been removed (the number of channels in a given sector varies from 8 to 37). The peak voice was computed for each sector from the Erlang-B formula for 2% blocking probability. For the IVHS data load, the same assumption was made of proportionality to the voice load (i.e., to the number of cellular users). Thus, the overall Urbansville IVHS data load was divided proportionally by the sectors.

**Table 8.1-1 Summary of DCTC FCC Filings (Nov. 1993)**

<b>DCTC Location Number</b>	<b>Location Code Name</b>	<b>N Latitude</b>	<b>W Longitude</b>	<b>Sector Number</b>	<b>Number of Channels</b>	<b>Antenna Type</b>	<b>ERP (W)</b>
3	Proud Lake	42-33-40	83-34-20	1	16	DB874H83	100
3	Proud Lake	42-33-40	83-34-20	2	24	DB874H83	20
3	Proud Lake	42-33-40	83-34-20	3	15	DB874H83	100
4	Novi	42-28-47	83-27-40	1	20	ALP8013-N	35
4	Novi	42-28-47	83-27-40	2	28	ALP8013-N	36
4	Novi	42-28-47	83-27-40	3	31	ALP8013-N	50
7	Mt. Clemens	42-32-26	82-53-25	1	20	ALP8013-N	75
7	Mt. Clemens	42-32-26	82-53-25	2	16	ALP8013-N	25
7	Mt. Clemens	42-32-26	82-53-25	3	31	ALP8013-N	27
8	Anchorville	42-45-25	82-44-25	1	12	ALP11011-N	86
8	Anchorville	42-45-25	82-44-25	2	19	ALP11011-N	60
8	Anchorville	42-45-25	82-44-25	3	12	ALP11011-N	89
9	Holly	42-47-02	83-32-05	1	16	PD-1136	83.2
9	Holly	42-47-02	83-32-05	2	15	PD-1136	83.2
12	WDIV Tower	42-28-58	83-12-19	1	16	ALP8010	12.5
12	WDIV Tower	42-28-58	83-12-19	2	24	ALP8010	50
12	WDIV Tower	42-28-58	83-12-19	3	24	ALP8010	50
14	Lake Angelous	42-41-25	83-17-50	1	24	DB-564	75
14	Lake Angelous	42-41-25	83-17-50	2	16	ALP8013-N	25
14	Lake Angelous	42-41-25	83-17-50	3	20	ALP8013-N	50
15	Rochester	42-40-42	83-07-27	1	24	DB-564	75
15	Rochester	42-40-42	83-07-27	2	22	DB-834	40
15	Rochester	42-40-42	83-07-27	3	28	DB874H83	75
16	Livonia	42-19-35	83-25-42	1	16	ALP8010	50
16	Livonia	42-19-35	83-25-42	2	19	ALP8010	75
16	Livonia	42-19-35	83-25-42	3	35	DB874H83	50
17	Walled Lake	42-34-09	83-26-30	1	20	DB874H83	50
17	Walled Lake	42-34-09	83-26-30	2	16	DB874H83	25
17	Walled Lake	42-34-09	83-26-30	3	19	DB874H83	50
18	Warren	42-36-27	83-02-33	1	28	DB874H83	100
18	Warren	42-36-27	83-02-33	2	24	DB874H83	50
18	Warren	42-36-27	83-02-33	3	19	DB874H83	25
19	Dearborn	42-18-52	83-09-07	1	16	ALP8013-N	73
19	Dearborn	42-18-52	83-09-07	2	24	DB882H60	64
19	Dearborn	42-18-52	83-09-07	3	27	DB874H83	64
21	Bloomfield Hills	42-36-32	83-17-35	1	20	DB872H83	25
21	Bloomfield Hills	42-36-32	83-17-35	2	28	ALP8013-N	30
21	Bloomfield Hills	42-36-32	83-17-35	3	26	DB874H83	25
22	Franklin	42-30-07	83-18-33	1	20	ALP8013-N	10
22	Franklin	42-30-07	83-18-33	2	32	ALP8013-N	6

22	Franklin	42-30-07	83-18-33	3	36	ALP8013-N	27
23	Redford	42-24-07	83-16-29	1	16	DB882H60	25
23	Redford	42-24-07	83-16-29	2	20	DB872H83	43
23	Redford	42-24-07	83-16-29	3	20	ALP8013-N	50
24	Strohs	42-20-12	83-01-03	1	20	DB883H60	75
24	Strohs	42-20-12	83-01-03	2	16	PD-1132	50
25	Detroit West	42-23-13	83-10-50	1	16	ALP8010-N	57
25	Detroit West	42-23-13	83-10-50	2	16	ALP8010-N	50
25	Detroit West	42-23-13	83-10-50	3	23	ALP8010-N	30
26	Detroit Baltimore	42-22-13	83-04-06	1	24	DB872H83	20
26	Detroit Baltimore	42-22-13	83-04-06	2	24	DB882H60	20
26	Detroit Baltimore	42-22-13	83-04-06	3	23	DB872H83	18
27	Grosse Pointe	42-24-11	82-58-08	1	20	ALP8010	50
27	Grosse Pointe	42-24-11	82-58-08	2	16	ALP8010	50
27	Grosse Pointe	42-24-11	82-58-08	3	19	ALP8010	50
28	Dearborn West	42-19-51	83-13-13	1	16	DB-834	100
28	Dearborn West	42-19-51	83-13-13	2	16	DB-834	100
28	Dearborn West	42-19-51	83-13-13	3	15	DB-834	100
29	East Detroit	42-29-28	83-02-32	1	16	DB-564S	100
29	East Detroit	42-29-28	83-02-32	2	16	DB-564S	100
29	East Detroit	42-29-28	83-02-32	3	15	DB-564S	100
30	Clawson	42-32-29	83-07-58	1	24	DB874H83	50
30	Clawson	42-32-29	83-07-58	2	24	DB874H83	50
30	Clawson	42-32-29	83-07-58	3	20	DB874H83	50
31	Bloomfield Hills	42-32-26	83-17-03	1	18	DB-834	100
31	Bloomfield Hills	42-32-26	83-17-03	2	15	DB-834	66
31	Bloomfield Hills	42-32-26	83-17-03	3	12	DB-834	66
32	Inkster	42-17-43	83-17-42	1	24	ALP8013-N	12.5
32	Inkster	42-17-43	83-17-42	2	24	ALP8013-N	50
32	Inkster	42-17-43	83-17-42	3	16	ALP8013-N	50
33	Hazel Park	42-27-55	83-05-01	1	16	DB-834	100
33	Hazel Park	42-27-55	83-05-01	2	16	DB-834	100
33	Hazel Park	42-27-55	83-05-01	3	16	DB-834	100
34	Pleasant Ridge	42-28-53	83-08-22	1	16	DB-834	50
34	Pleasant Ridge	42-28-53	83-08-22	2	24	DB874H83	50
34	Pleasant Ridge	42-28-53	83-08-22	3	23	ALP8007-N	12.5
35	Birmingham	42-32-43	83-11-37	1	24	ALP8010	50
35	Birmingham	42-32-43	83-11-37	2	16	ALP8010	25
35	Birmingham	42-32-43	83-11-37	3	19	ALP8010	50
36	Northville	42-23-50	83-26-11	1	20	ALP8010-N	35
36	Northville	42-23-50	83-26-11	2	24	ALP8010-N	67
36	Northville	42-23-50	83-26-11	3	16	ALP8013-N	100
37	Farmington Hills	42-29-52	83-22-45	1	12	LPD-7907	58
37	Farmington Hills	42-29-52	83-22-45	2	16	LPD-7907	58
37	Farmington Hills	42-29-52	83-22-45	3	13	LPD-7907	58
38	Auburn Hills	42-38-03	83-12-58	1	14	DB874H83	100

38	Auburn Hills	42-38-03	83-12-58	2	12	DB874H83	50
38	Auburn Hills	42-38-03	83-12-58	3	19	DB874H83	75
39	Sterling Heights	42-33-01	83-00-03	1	14	DB-834	80
39	Sterling Heights	42-33-01	83-00-03	2	12	DB-834	80
39	Sterling Heights	42-33-01	83-00-03	3	16	DB-834	80
40	Southfield	42-27-00	83-16-57	1	16	DB-834	75
40	Southfield	42-27-00	83-16-57	2	16	DB-834	75
40	Southfield	42-27-00	83-16-57	3	15	DB-834	75
42	Detroit N.	42-27-18	83-00-28	1	16	DB-834	100
42	Detroit N.	42-27-18	83-00-28	2	16	DB-834	100
42	Detroit N.	42-27-18	83-00-28	3	16	DB-834	100
43	Big Beaver	42-34-35	83-07-37	1	16	DB-834	100
43	Big Beaver	42-34-35	83-07-37	2	16	DB-834	100
43	Big Beaver	42-34-35	83-07-37	3	16	DB-834	100
44	Highland Park	42-24-07	83-07-29	1	16	DB-834	100
44	Highland Park	42-24-07	83-07-29	2	16	DB-834	100
44	Highland Park	42-24-07	83-07-29	3	15	DB-834	100
45	Oak Park	42-26-20	83-11-41	1	16	DB-834	100
45	Oak Park	42-26-20	83-11-41	2	16	DB-834	100
45	Oak Park	42-26-20	83-11-41	3	15	DB-834	100
46	Taylor	42-13-34	83-14-08	1	16	DB-834	100
46	Taylor	42-13-34	83-14-08	2	16	DB-834	100
46	Taylor	42-13-34	83-14-08	3	16	DB-834	100
47	Farmington	42-26-26	83-21-52	1	20	DB-834	30
47	Farmington	42-26-26	83-21-52	2	11	DB874H83	50
47	Farmington	42-26-26	83-21-52	3	16	DB-834	63
48	East Livonia	42-22-24	83-22-13	1	20	ALP8010-N	67
48	East Livonia	42-22-24	83-22-13	2	16	ALP8013-N	30
48	East Livonia	42-22-24	83-22-13	3	14	ALP8013-N	13
49	Minnow Lake	42-34-44	83-16-54	1	19	ALP8013-N	100
49	Minnow Lake	42-34-44	83-16-54	2	16	ALP8013-N	50
49	Minnow Lake	42-34-44	83-16-54	3	16	ALP8013-N	100
50	Lathrup	42-29-12	83-16-10	1	20	ALP8010	80
50	Lathrup	42-29-12	83-16-10	2	20	ALP8010	40
50	Lathrup	42-29-12	83-16-10	3	15	ALP8010	25
51	Harper Woods	42-28-05	82-55-14	1	20	ALP8013-N	79
51	Harper Woods	42-28-05	82-55-14	2	20	ALP8010-N	30
51	Harper Woods	42-28-05	82-55-14	3	14	ALP8013-N	79
52	Orchard Lake	42-33-35	83-22-20	1	19	ALP8010-N	25
52	Orchard Lake	42-33-35	83-22-20	2	20	ALP8010-N	25
52	Orchard Lake	42-33-35	83-22-20	3	10	ALP8013-N	100
53	Troy	42-36-13	83-10-05	1	16	DB-834	100
53	Troy	42-36-13	83-10-05	2	16	DB-834	100
53	Troy	42-36-13	83-10-05	3	16	DB-834	100
54	Elizabeth Lake	42-38-21	83-22-52	1	16	DB-834	100
54	Elizabeth Lake	42-38-21	83-22-52	2	16	DB-834	100

54	Elizabeth Lake	42-38-21	83-22-52	3	16	DB-834	100
55	Knollwood	42-32-39	83-19-46	1	16	DB-834	100
55	Knollwood	42-32-39	83-19-46	2	16	DB-834	100
55	Knollwood	42-32-39	83-19-46	3	16	DB-834	100
56	Cranbrook	42-35-05	83-14-44	1	10	LPD7907	100
56	Cranbrook	42-35-05	83-14-44	2	12	LPD7907	100
56	Cranbrook	42-35-05	83-14-44	3	8	LPD7907	100
57	Tally Hall	42-31-41	83-21-34	1	20	DB882H60	50
57	Tally Hall	42-31-41	83-21-34	2	24	DB882H60	50
57	Tally Hall	42-31-41	83-21-34	3	19	DB872H83	100
58	Airport	42-13-25	83-23-28	1	32	DB874H83	67.6
58	Airport	42-13-25	83-23-28	2	16	DB874H83	100
58	Airport	42-13-25	83-23-28	3	20	DB874H83	200
59	Mt. Clemens North	42-36-47	82-52-57	1	24	DB-834	100
59	Mt. Clemens North	42-36-47	82-52-57	2	20	DB-834	61
59	Mt. Clemens North	42-36-47	82-52-57	3	16	DB-834	40
60	Royal Oak	42-30-54	83-11-03	1	20	DB882H60	50
60	Royal Oak	42-30-54	83-11-03	2	20	DB882H60	50
60	Royal Oak	42-30-54	83-11-03	3	19	DB882H60	50
61	Madisson Heights	42-30-51	83-05-08	1	16	DB-834	100
61	Madisson Heights	42-30-51	83-05-08	2	16	DB-834	100
61	Madisson Heights	42-30-51	83-05-08	3	15	DB-834	100
62	Beverly Hills	42-30-51	83-13-28	1	16	ALP8010	50
62	Beverly Hills	42-30-51	83-13-28	2	16	ALP8010	50
62	Beverly Hills	42-30-51	83-13-28	3	16	ALP8010	50
64	Hamtramck	42-24-34	83-02-18	1	16	DB-834	75
64	Hamtramck	42-24-34	83-02-18	2	16	DB-834	55
64	Hamtramck	42-24-34	83-02-18	3	16	DB-834	75
67	Murray Lake	42-38-17	83-39-25	1	8	DB872H83	100
67	Murray Lake	42-38-17	83-39-25	2	8	DB872H83	50
67	Murray Lake	42-38-17	83-39-25	3	12	DB872H83	100
68	Oakwood	42-47-14	83-18-20	1	16	DB-560	100
69	Romeo	42-50-03	83-00-44	1	16	DB-560	100
72	Tiger Stadium	42-20-08	83-05-55	1	16	DB-834	67
72	Tiger Stadium	42-20-08	83-05-55	2	16	DB-834	30
72	Tiger Stadium	42-20-08	83-05-55	3	12	DB-834	67
73	Roseville	42-29-28	82-58-53	1	16	DB872H83	50
73	Roseville	42-29-28	82-58-53	2	16	DB872H83	50
73	Roseville	42-29-28	82-58-53	3	16	DB872H83	50
75	Orion Township	42-43-07	83-14-09	1	16	ALP8013-N	100
75	Orion Township	42-43-07	83-14-09	2	16	ALP8013-N	75
75	Orion Township	42-43-07	83-14-09	3	11	ALP8013-N	12.5
76	Ferndale	42-26-19	83-06-25	1	20	DB874H83	50
76	Ferndale	42-26-19	83-06-25	2	20	DB874H83	50
76	Ferndale	42-26-19	83-06-25	3	19	DB874H83	50
77	Northville North	42-26-27	83-26-17	1	12	DB882H60	50

77	Northville North	42-26-27	83-26-17	2	12	DB882H60	25
77	Northville North	42-26-27	83-26-17	3	8	DB872H83	100
79	Clarkston	42-43-54	83-22-28	1	16	DB874H83	100
79	Clarkston	42-43-54	83-22-28	2	16	DB874H83	100
79	Clarkston	42-43-54	83-22-28	3	16	DB874H83	100
83	Pontiac South	42-38-53	83-16-09	1	16	DB874H83	50
83	Pontiac South	42-38-53	83-16-09	2	16	DB874H83	50
83	Pontiac South	42-38-53	83-16-09	3	16	DB874H83	50
84	Downtown Detroit	42-19-37	83-02-44	1	16	DB882H60	50
84	Downtown Detroit	42-19-37	83-02-44	2	15	DB874H83	50
85	Mound	42-33-09	83-02-42	1	16	DB874H83	25
85	Mound	42-33-09	83-02-42	2	12	DB874H83	50
85	Mound	42-33-09	83-02-42	3	12	DB874H83	50
86	Canton	42-16-38	83-27-04	1	16	DB874H83	50
86	Canton	42-16-38	83-27-04	2	16	DB874H83	50
86	Canton	42-16-38	83-27-04	3	16	DB874H83	100
87	Detroit West II	42-24-07	83-13-13	1	12	DB874H83	50
87	Detroit West II	42-24-07	83-13-13	2	12	DB874H83	50
87	Detroit West II	42-24-07	83-13-13	3	12	DB874H83	50
89	Livonia Mall	42-24-49	83-20-11	1	12	DB874H83	50
89	Livonia Mall	42-24-49	83-20-11	2	12	DB874H83	50
89	Livonia Mall	42-24-49	83-20-11	3	12	DB874H83	50
90	Northwestern Hwy	42-27-56	83-14-00	1	16	DB874H83	14
90	Northwestern Hwy	42-27-56	83-14-00	2	16	DB874H83	50
90	Northwestern Hwy	42-27-56	83-14-00	3	16	DB874H83	25
92	Rochester South	42-39-26	83-09-19	1	12	ALP8013-N	50
92	Rochester South	42-39-26	83-09-19	2	12	ALP8013-N	50
92	Rochester South	42-39-26	83-09-19	3	12	ALP8013-N	50
94	Grosse Pointe Park	42-22-16	82-57-06	1	12	ALP4014-N	100
94	Grosse Pointe Park	42-22-16	82-57-06	2	12	ALP6011-N	50
95	Airport North	42-14-44	83-18-25	1	12	ALP8010	50
95	Airport North	42-14-44	83-18-25	2	12	ALP8010	50
95	Airport North	42-14-44	83-18-25	3	16	ALP8010	100
96	Dearborn Heights	42-20-59	83-16-32	1	16	DB874H83	50
96	Dearborn Heights	42-20-59	83-16-32	2	16	DB874H83	25
96	Dearborn Heights	42-20-59	83-16-32	3	16	DB874H83	50
99	Grosse Pointe Yacht Club	42-26-04	82-52-21	1	8	LPD-7907	5
99	Grosse Pointe Yacht Club	42-26-04	82-52-21	2	8	LPD-7907	100
114	White Lake	42-39-29	83-32-45	1	8	ALP8013-N	50
114	White Lake	42-39-29	83-32-45	2	8	ALP8013-N	50
114	White Lake	42-39-29	83-32-45	3	12	ALP8013-N	50
115	Keego Harbor	42-36-42	83-19-47	1	16	ALP8010	25
115	Keego Harbor	42-36-42	83-19-47	2	12	ALP8010	25
115	Keego Harbor	42-36-42	83-19-47	3	12	ALP8010	25
116	Garfield	42-36-22	82-57-04	1	16	ALP8010	100
116	Garfield	42-36-22	82-57-04	2	12	ALP8010	50

116	Garfield	42-36-22	82-57-04	3	16	ALP8010	50
120	Halstead	42-29-35	83-25-18	1	16	DB874H83	25
120	Halstead	42-29-35	83-25-18	2	16	DB874H83	25
120	Halstead	42-29-35	83-25-18	3	16	DB874H83	50
124	Stephenson Hwy	42-30-37	83-06-58	1	16	ALP8010	50
124	Stephenson Hwy	42-30-37	83-06-58	2	16	ALP8010	25
124	Stephenson Hwy	42-30-37	83-06-58	3	12	ALP8010	23.3
132	Troy South	42-33-47	83-09-03	1	16	DB874H83	25
132	Troy South	42-33-47	83-09-03	2	16	DB874H83	25
132	Troy South	42-33-47	83-09-03	3	16	DB874H83	25
133	Birmingham Downtown	42-32-44	83-12-51	1	20	DB872H83	100
133	Birmingham Downtown	42-32-44	83-12-51	2	20	DB872H83	50
133	Birmingham Downtown	42-32-44	83-12-51	3	20	DB872H83	50
150	Allen Park	42-16-19	83-12-04	1	16	DB874H83	25
150	Allen Park	42-16-19	83-12-04	2	16	DB874H83	50
150	Allen Park	42-16-19	83-12-04	3	16	DB874H83	25
155	Haggerty x 14 Mile Road	42-31-42	83-26-28	1	16	ALP8010	50
155	Haggerty x 14 Mile Road	42-31-42	83-26-28	2	16	ALP8010	50
155	Haggerty x 14 Mile Road	42-31-42	83-26-28	3	16	ALP8010	100

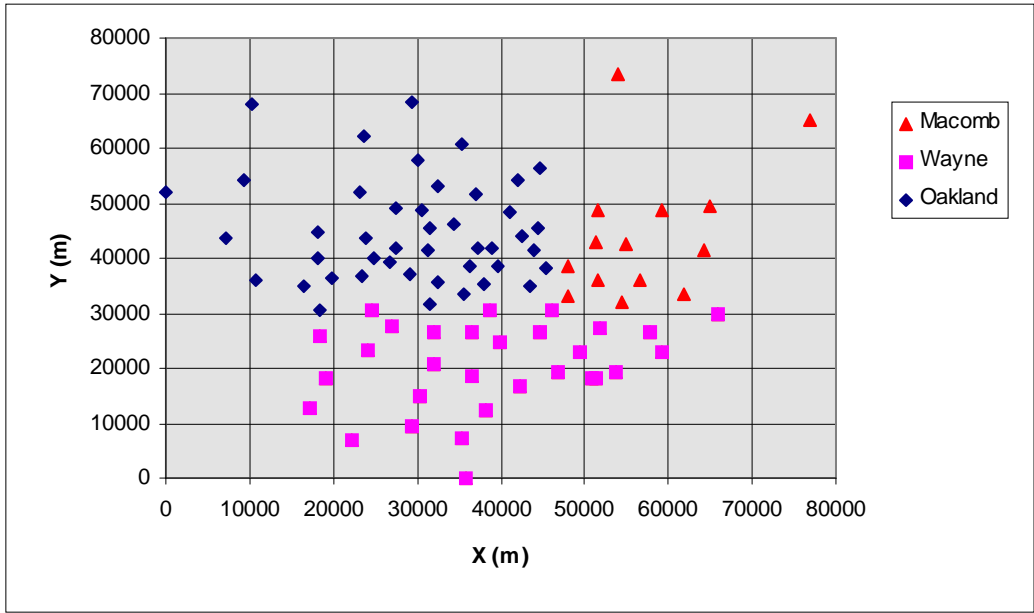
**Table 8.1-2 Characterization of the DCTC Site #25**

SITE_NAME	Detroit West
SITE_ID	DCTC-025
LATITUDE	42 23 13 N
LONGITUDE	83 10 50 E
FREQUENCY	860 MHz
<b>VOICE_CHANNEL_DATA</b>	
NUMBER_OF_SECTORS	3
FOR_SECTOR	1
ANTENNA_HEIGHT	159 FT
ANTENNA_MODEL_NUMBER	ALP8010-N
ANTENNA_MAIN_LOBE	30 degrees
ERP	57 W
NUMBER_OF_CHANNELS	16
CONTROL_CHANNEL	333
<b>VOICE_CHANNELS 270 250 228 207 186 165 144 123 102 81 60 39 18</b>	
FOR_SECTOR	2
ANTENNA_HEIGHT	159 FT
ANTENNA_MODEL_NUMBER	ALP8010-N
ANTENNA_MAIN_LOBE	150 degrees
ERP	50 W
NUMBER_OF_CHANNELS	16
CONTROL_CHANNEL	321
<b>VOICE_CHANNELS 258 237 216 195 174 153 132 111 90 69 48 27 6</b>	
FOR_SECTOR	3
ANTENNA_HEIGHT	159 FT
ANTENNA_MODEL_NUMBER	ALP8010-N
ANTENNA_MAIN_LOBE	270 degrees
ERP	30 W
NUMBER_OF_CHANNELS	23
CONTROL_CHANNEL	316
<b>VOICE_CHANNELS 708 690 687 669 666 295 274 253 232 211 190 169 148 127 106 85 64 43 22 1</b>	



**Table 8.1-3 Manufacturer-Provided Pattern for DB874H83 Antenna**

Gain (dB)	11.8					(Continued)	
Manufacturer	Decibel	Products				Angle	dBi
Sectored						-9.1	7.6
						-7.9	8.9
Horizontal Pattern						-5.4	10.5
Symmetric						-2.6	11.4
Equally Spaced						-0.3	11.8
From/To/Step	0	180	5			0	11.8
	11.8	11.7	11.5	11.3	11.1	1	11.6
	10.8	10.4	9.1	8.7	8	1.8	11.5
	7.4	6.5	5.7	4.9	4.1	3.3	11.1
	1.9	0.8	-0.4	-1.3	-2.1	4.9	10.4
	-3.3	-4.3	-7.6	-9.3	-10.9	6.2	9.5
	-12.2	-13.1	-12.1	-10.9	-8.5	6.8	9.1
						8.3	7.8
Vertical Pattern						9.9	6.1
Asymmetric						10.4	5.2
Unequally Spaced						11	4
Angle	dBi					12.5	2
	-83.1	-21.7				13.2	0.7
	-74.3	-17.4				13.7	-0.7
	-71.8	-17.1				14.1	-4.3
	-67.2	-18.9				14.6	-5.4
	-66.7	-17.6				14.9	-12.4
	-57.1	-14.2				15.2	-11.9
	-56.7	-19.3				15.7	-14
	-56.3	-20.4				17.4	-14
	-55.9	-12.9				18.8	-6.9
	-52.9	-9.3				19	-8.6
	-46.4	-6.9				19.1	-9.7
	-43.3	-7.5				19.4	-5.2
	-41.3	-8.2				20.8	-2.3
	-39.6	-11.1				22.8	-0.8
	-38.4	-13.9				24.6	-0.2
	-35.4	-16				29.5	-1.7
	-34.5	-15.8				32.5	-5.1
	-33.3	-13.9				34.1	-9.9
	-32.7	-10.8				34.6	-14.6
	-31.1	-7.4				37.9	-16.6
	-28.5	-4.8				41	-13.7
	-24.5	-3.4				42.3	-10.6
	-22.9	-4.2				44.5	-8.5
	-21.6	-5.7				46.5	-7.3
	-21.3	-7.3				51.5	-7.8
	-20.3	-8.8				55	-10.8
	-19.6	-9.5				57.9	-15.2
	-18.7	-10.5				60.5	-17.7
	-17.2	-8.2				62.2	-17.8
	-16.5	-6.1				66.3	-15.7
	-16.4	-4.2				72.8	-12.5
	-14.9	-2				78	-12.3
	-14.4	0.2				83.9	-14.9
	-13.4	2.2				87	-16
	-12.2	4				89.2	-16.9
	-10.9	5.6				90	-21.7



**Figure 8.1-1 Base Station Locations in the Detroit Area**

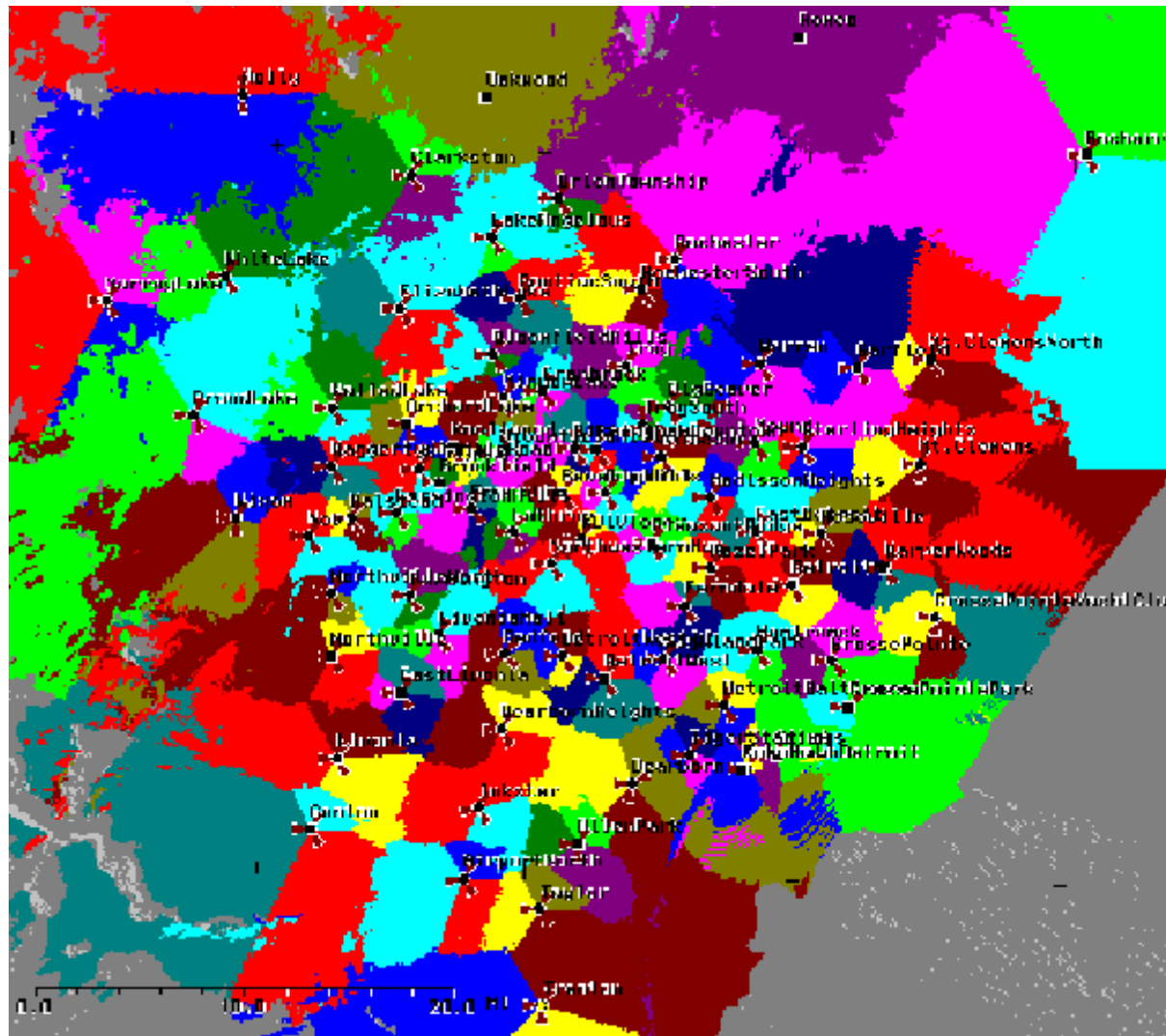


Figure 8.1-2 Best Server Map of the Detroit Area obtained using GRANET

#### 8.1.1.1.2 2012 (Phase I) Data Loads

The performance study of a CDPD system began in Phase I by establishing the capacity of what was called a minimal CDPD deployment, which was one reserved CDPD channel per sector.

The analysis performed in Phase I for the data loads anticipated for 2012 was for one reserved CDPD channel plus one dynamically assigned channel. This analysis is reported herein, even though the loads have since changed. The purpose of this is to illustrate system performance when the data loads are much higher than those considered in the 2002 time frame.

#### 8.1.1.1.3 2002 (Phase II) Data Loads

Three case studies of CDPD overlaid on cellular AMPS voice will be presented for Urbansville for the 2002 time frame. A minimal CDPD deployment (defined as one CDPD channel per sector) was initially considered, with the channel reserved for exclusive use of CDPD and no additional dynamically assigned channel. Later, a totally dynamic solution was also considered with three dynamically assigned CDPD channels but with no channels reserved for CDPD. The results from both cases will be reported in detail in the sections that will follow.

##### *8.1.1.1.3.1 Deployment 1: One Reserved CDPD Channel (No Dynamic)*

MOSS, the GTE Laboratories (GTEL) proprietary mobile radio simulation package (see Appendix I), was exercised first to determine the performance of a mix of voice and data from ITS users only for that minimal CDPD deployment, based upon coverage information obtained with another GTEL's proprietary package, GRANET. The same system was also simulated for the case of a mix of voice and data from ITS and Non-ITS users. Finally, an incident was considered, based upon information obtained from MITRE (February 1, 1996) taken from their vehicular traffic simulations, on top of the above mix of voice and data from ITS and non-ITS users.

##### *8.1.1.1.3.2 Deployment 2: Three Dynamically Assigned CDPD Channels (No Reserved)*

Given that CDPD was in fact designed to operate in a dynamic mode (making use of the idle periods between calls) another solution was also analyzed. Three CDPD channels are dynamically assigned to CDPD traffic as a function of availability and demand. That number corresponds to an optimal use of the available idle moments during the peak period. A fourth one would provide minimal improvement (diminishing returns). The data loads considered here correspond to the mix of voice and data from ITS and non-ITS users.

#### **8.1.1.2 Thruville 2002**

In the case of Thruville, based upon the Philadelphia-Trenton Corridor, getting cellular deployment information was much more difficult. The information obtained from the FCC filings was of much poorer quality than that of Detroit, with only incomplete information available for many cells. The reasons for this shortcoming are two fold: 1) the filing rules give some latitude to the cellular companies as to the detail of what is reported, and 2) the rules have been changed in the interim, reducing the requirements for information (presently only information concerning the sites that affect surrounding markets needs to be provided).

As a consequence, some radio planning had to be performed to complete the information obtained from the FCC. The quality of the complete deployment, especially in terms of interference, had to be tested to guarantee acceptable performance before CDPD simulations could begin.

Two scenarios were simulated for the case of one reserved CDPD channel and no additional dynamically assigned channel: ITS only, and ITS plus non-ITS. The case of ITS plus non-ITS with Incident, could not be analyzed in time (priority was given to simulating the n-dynamic CDPD channels deployment). The incident data was obtained from MITRE, taken from their vehicular traffic simulations using Integration. The fact that the simulated roadway links, represented by link numbers, had no obvious correspondence to actual roadway segments made the mapping extremely difficult.

### **8.1.1.3 Mountainville**

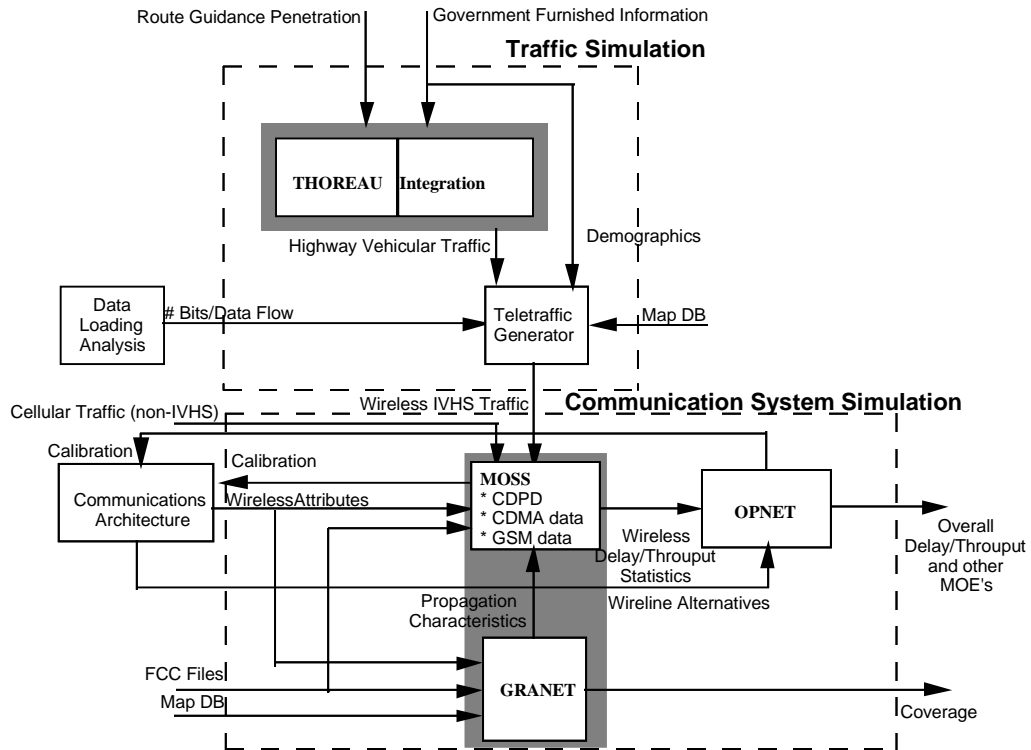
The cellular deployment information for Mountainville was not much better than that of Philadelphia. However, having decided that CDPD would not be exercised for the scenario for the 2002 time frame, the task became much simpler. The only concern became the coverage provided by the present cellular deployment, rather than its frequency plan.

GRANET was used to calculate the coverage for the hilly terrain of Lincoln County, Montana. Only this coverage result is provided for this scenario.

### **8.1.2 Simulation Strategy**

The relationship between the communication simulation, traffic simulation and other architecture development tasks is shown in Figure 8.1-3. Teletraffic information is derived by the Teletraffic Generator from the traffic simulation packages (Integration and THOREAU), and from demographic data, independently obtained, on the government-selected scenarios. Market penetration plays a key role.

The market penetration drives the teletraffic figures, and through that strongly impacts the configuration and technology selection for the communication architecture. It is, therefore, critical to arrive at realistic projections. It is also obvious that the Phase I definition by MITRE of “market penetration” as route guidance penetration left out most of the services and, as is shown in great detail in the Data Loading analysis, most of the teletraffic as well.



**Figure 8.1-3 Communication System Simulation/Evaluation Methodology**

Preliminary market studies indicate that market penetration will vary significantly by type of service, as it will vary within a type of service by application or group of applications. The penetration is anticipated to be high for Commercial Vehicle Operation (CVO), Advanced Public Transit Systems (APTS), and Emergency Vehicle Management (EVM), but significantly smaller for ATIS, even in the 20 year time frame. This information is covered extensively in the Data Loading section (Section 5), and is summarized for the reader's convenience in Table 8.1-4 for the 2002 time frame. The ranges shown correspond to the penetrations for the different applications within a type of service and/or group of users.

**Table 8.1-4 Market Penetration Figures Derived from Preliminary Market Studies**

<b>2002</b>	<b>Penetration</b>
Personal Information Access	7 - 10%
Transit Vehicles	10 - 100%
Traffic Management	100%
Private Vehicle	7 - 100%
Emergency Vehicles	100%
CVO Local	7 - 50%
CVO Long Haul	7 - 100%

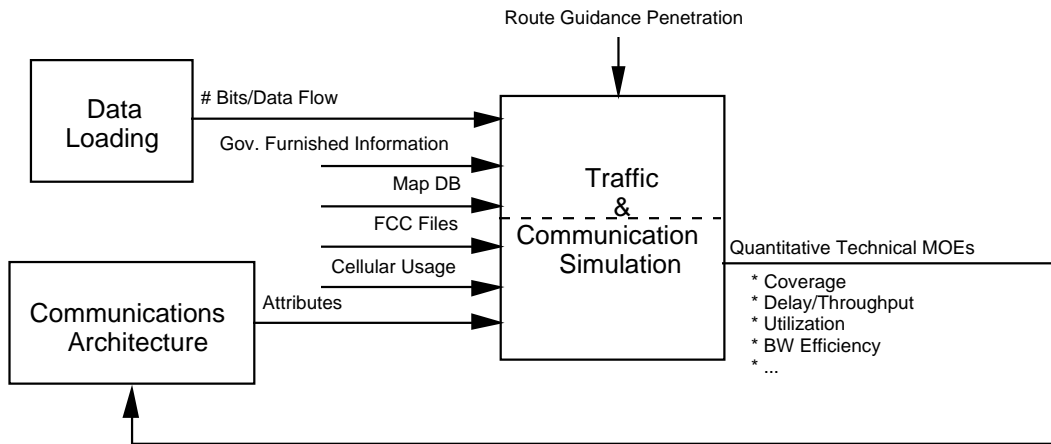
MOSS was used extensively to simulate CDPD systems using actual cellular deployment information obtained from FCC filings. At least one CDPD channel per sector was assumed in the urban scenario (i.e., "fully deployed", in a regional, geographic sense). Note that there is no incompatibility between the use of the term "minimal deployment" (channel-wise) for the case of one reserved CDPD channel per sector, and the full geographic deployment nomenclature above.

MOSS uses the ITS teletraffic information from the Teletraffic Generator, as well as cellular non-ITS traffic information (initially voice only, later also non-ITS data), in combination with the wireless attributes from the Communication Architecture to compute, using the propagation characteristics obtained from GRANET, delay/throughput statistics for the wireless portion of the communication system.

Besides propagation information, GRANET also provides coverage, C/I, and best server information based upon deployment information. This information includes characteristics of the base stations, their locations, and the underlying terrain topography, morphology, and land-use/land-cover (partially derived from the latest commercially available GIS data bases).

The reverse link delay characterization obtained from MOSS is then fed into the OPNET protocol simulation, and also into the wireline simulations. OPNET was already used in Phase I to simulate the wireline network (in fact, the fixed, point-to-point network, since it can also analyze the microwave links between any two nodes), and to perform the comparison of a few technological and topological wireline alternatives.

To conclude, the outputs of the Communication System Simulation (Figure 8.1-4) are, among others, the quantitative technical MOE's – Coverage, Delay, Throughput, and information on a link by link level about utilization and bandwidth efficiency.



**Figure 8.1-4 Quantitative Technical MOE's**

As in Phase I, system performance is studied during the peak period, and in the case of an incident. For the latter, the same approach of analyzing the worst-case incident during the rush hour is followed, now in with the incident locations chosen by the Government Team. Information on the effect of the incidents was recently obtained from MITRE (February 1, 1996).

### 8.1.3 CDPD Protocol Overhead

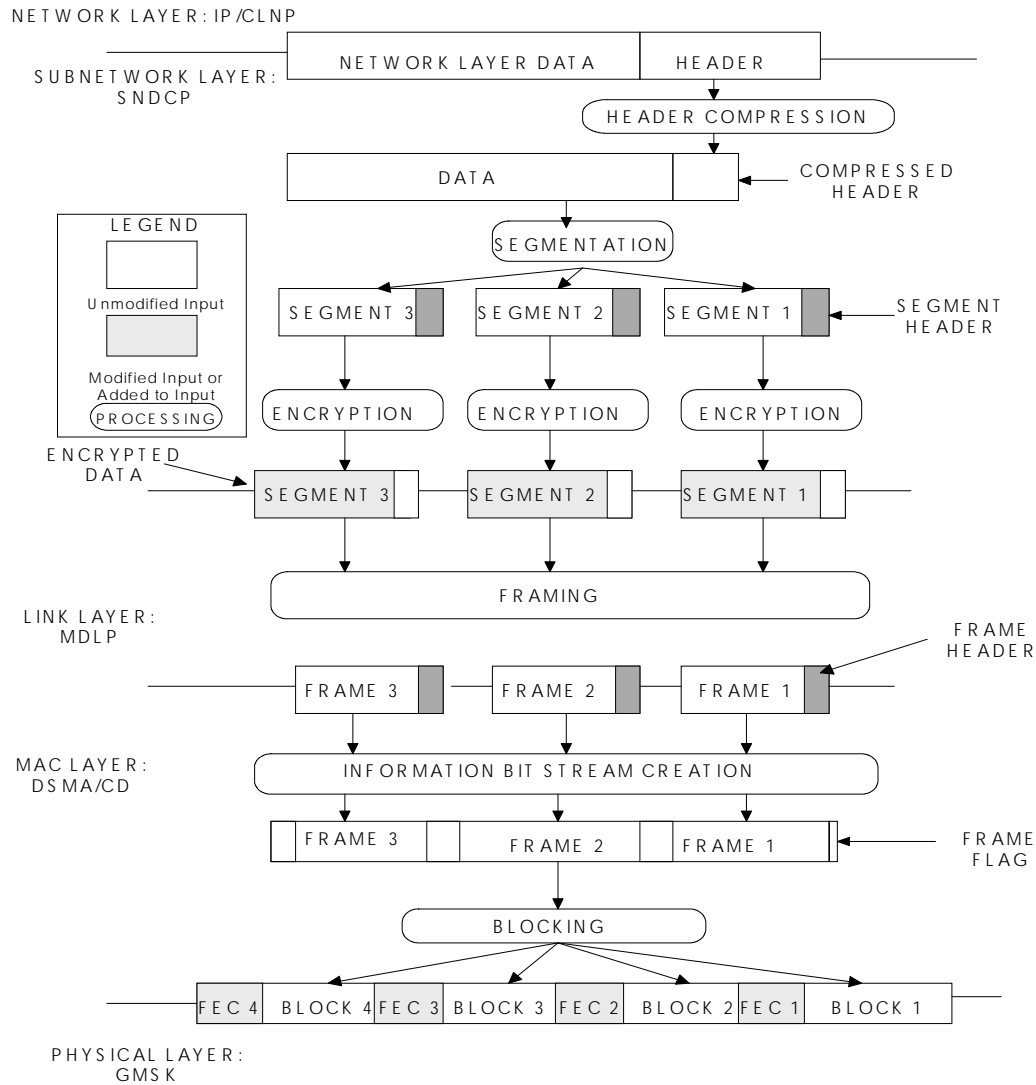
For convenience, Figure 8.1-5 reproduces the CDPD protocol stack<sup>1</sup>, since it will enable us to identify all the steps that introduce overhead. We can begin from the top. Even if outside of the picture, we have the layers of the protocol above IP, namely TCP (or, better, the transport family of protocols, including in particular UDP), and the remaining upper layers that we conveniently group as the Application layer. Here we do not account for Application overhead, since it can be included in the message that is passed to the Transport layer (TCP or UDP) which is considered below. In practice, the applications' developer will have to address all the details of their overhead to arrive at a successful product.

At the Transport layer, TCP will add 20 bytes of overhead. Note that the TCP payload has to be an integer number of bytes long – this is the first level that must be quantified, although most applications, especially those generating textual data, already do that. UDP, the other Transport protocol alternative would only add 8 bytes. Its behavior, however, is quite different from that of TCP. TCP guarantees delivery of the messages to the destination, UDP doesn't.

The reason to maintain TCP here is two-fold: (1) it is our observation that, at the infancy of any service, developers tend to seek the advantage of an application that works as soon as possible – only later, with experience, will they worry about making it “slick and slim”; (2) by using the larger overhead we are “stretching” as much as possible the communication system under analysis, to obtain conservative assessments.

<sup>1</sup> *TCP/IP Illustrated - Vol. I: The Protocols*, W. Richard Stevens, Addison-Wesley, 1994.





**Figure 8.1-5 CDPD Protocol Stack (Cellular Digital Packet Data System Specification, Release 1.0)**

At the Network layer, IP adds another 20 bytes of overhead. Then, at the sub-network layer, SNDP performs TCP/IP header compression<sup>2</sup>. If more than one packet is required in a given transaction, significant header compression gain can be achieved (from 40 to 3 on average). In the case of the wide area ITS applications, almost all the transactions identified thus far require only one packet in each direction. No significant gain is thus to be expected from that step.

Next we have the Segmentation and Framing steps. One or two (1-2) additional bytes are added at segmentation time, and two to six (2-6) additional bytes are added at MDLP framing. Due to system settings, 2 bytes are added during segmentation (for non-guaranteed delivery), and we opted to average the number of bytes added by MDLP. Hence, we have added a total of 6 bytes during Segmentation and Framing.

<sup>2</sup> "Compressing TCP/IP Headers for Low-Speed Serial Links", V. Jacobson, Network Working Group Request for Comments 1144, Feb. 1990

Finally, at the MAC layer, during the process of bit stream creation, additional zeros have to be intercalated in the approximately random (due to the previous encryption step) stream of framed data bits to avoid the accidental occurrence of the Flag or Abort sequence [01111110]. No more than five consecutive 1's can thus be allowed, which implies that zeros have to be padded as soon as five consecutive 1's are detected.

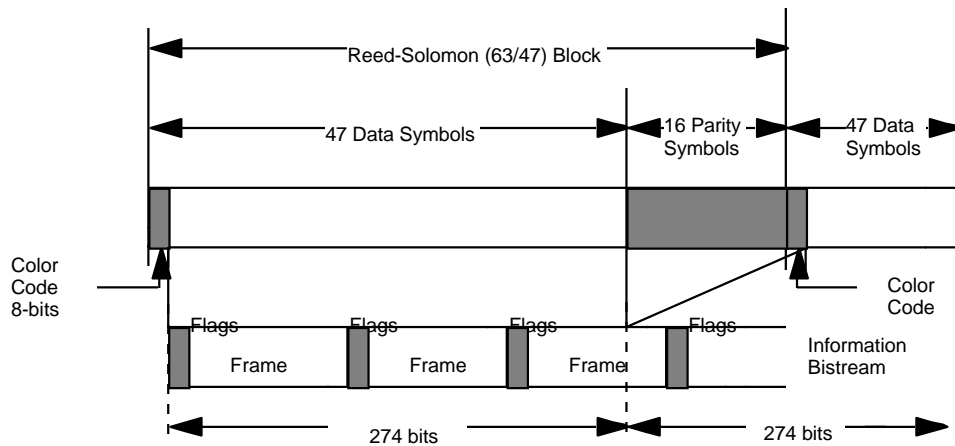
The number of zeros thus added to the frame is a random number with a mean that is close to 1.6% of the length of the message<sup>3</sup>, although its distribution has a considerable positive tail that can have some impact, as we will see. It is easy to see that a simple zero added at the wrong time can make it necessary to use an additional RS-block to carry the message.

When the zero padded bit stream is finally available, different color coding is added for each link (see Figure 8.1-6), and the bits are prepared to be sent over the mobile link by using a 63/47 Reed-Solomon (RS) error correcting code. The CDPD specification establishes the Reed-Solomon (RS)-block as the "quantum of information" transmitted over the CDPD wireless channel. All messages are carried in an integer number of RS-blocks, even if they do not fill the "envelope". This final quantization step has the most significance, since it determines the characteristics of the CDPD traffic (in terms of the proportion of messages being transmitted in a given number of RS-blocks).

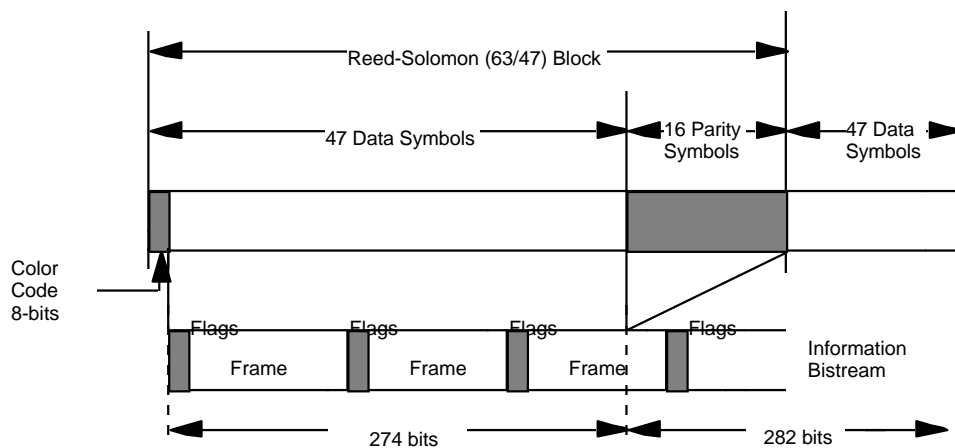
---

<sup>3</sup> "The Effects of Zero Padding on the CDPD Wide-Area IVHS Data Load", Jorge M. Pereira, Personal, Indoors, and Mobile Communications Conference, PIMRC '95, Toronto, Canada, September 26-29, 1995.

### Forward Channel Framing and Block Structure



### Reverse Channel Framing and Block Structure



**Figure 8.1-6 Framing and Block Structure Showing the Color Code**

It is important to point out that from a service and billing perspective, the customer pays per byte and is not responsible for any network overhead at the IP (network) layer or below. Whatever takes place in the process of segmentation, framing, zero padding, or blocking, is completely transparent to the user and has no impact on the cost of the service. Also, any re-transmissions at any of these lower layers are not the responsibility of the customer. (These overheads have, nevertheless, an impact on network performance, and that is why they are analyzed here.) The lower layers of the protocol guarantee the error-free delivery of the message to the MDBS or the M-ES. If that is not possible due to congestion, or repeated occurrence of errors during the transmission (39 unsuccessful lower-layer re-transmissions are tried before the system quits and warns the upper-layers), then the user does not pay for the undelivered (but later) delivered bytes.

However, any re-transmissions generated at the higher layers of the protocol, namely by TCP (due to time-outs and lost packets elsewhere in the network), will be of the responsibility of the user, i.e., the user will have to pay again for the transmitted bytes.

For the purpose of computing and characterizing the CDPD traffic resulting from the wide area wireless ITS data loading, all the above overhead, and mainly the quantization steps were taken into account. The results are presented in the following sections for the two scenarios analyzed for the 2002 time frame.

#### 8.1.4 Non-ITS Applications CDPD Data Loads

In Section 7.3, we concluded that, as a result of the decision to share deployed infrastructure with other users, the traffic generated by non-ITS users will have an impact on ITS performance. In that section, we analyzed in detail the different types of non-ITS traffic to be expected, and came to the conclusion that E-mail and Internet access, the latter dominated by WWW access, would clearly dominate the non-ITS traffic.

The message sizes associated with those two applications were studied in detail, and are reproduced here for the reader's convenience. Figure 8.1-7 shows the message distribution for Wireless E-mail Access. E-mail, even if wireless, is a two-way application, so the same distribution applies both in the forward and in the reverse directions. Figure 8.1-8 shows, lacking any more detailed information, the average file transfer size in bytes, as a function of the time of the day, from a typical WWW server to the user, i.e., in the forward direction. The reverse direction traffic for Internet access is much smaller, consisting mainly of transmission of URL's. Any other traffic is mainly of the E-mail type, especially since e-mail messages can be sent from the most popular WWW browsers.

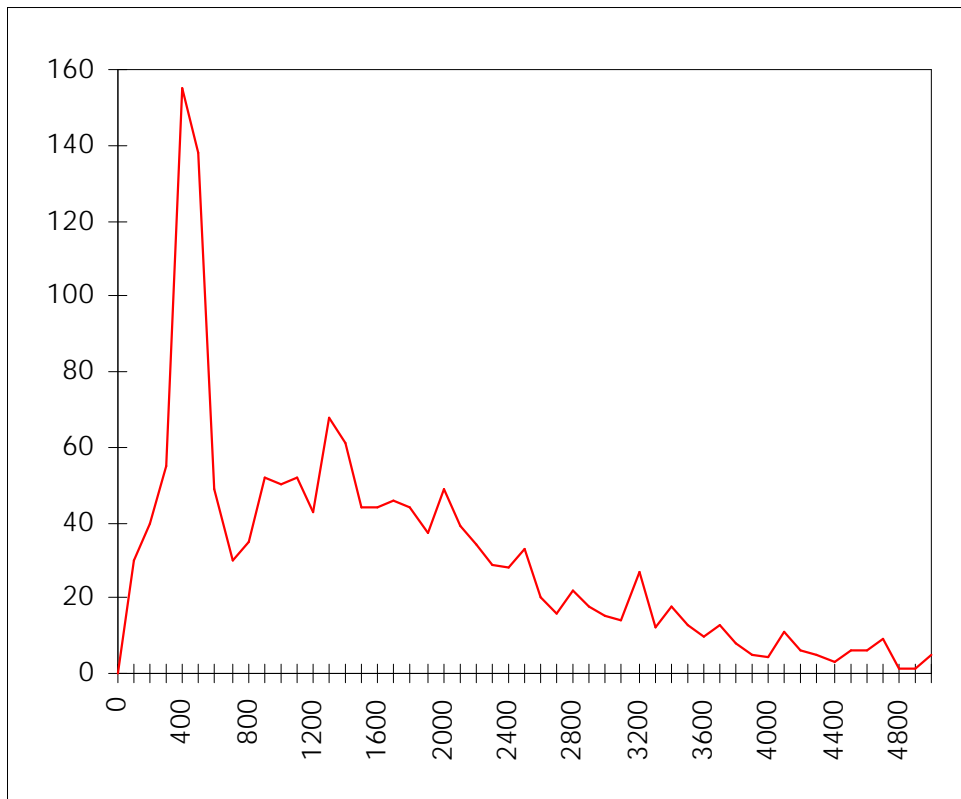
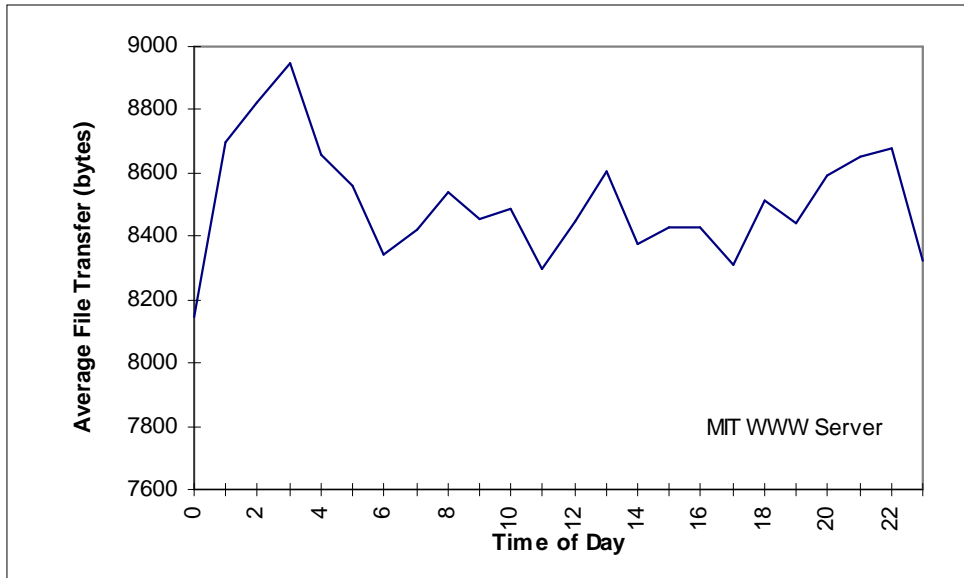


Figure 8.1-7 Histogram of Wireless E-mail Message Sizes (up to 5 kbytes)



**Figure 8.1-8 Average File Transfer Size for the MIT WWW Server (All day Average: 8490 bytes)**

In order to approximate the non-ITS traffic, we used the above information to compute the distribution of the CDPD packet lengths (in RS-blocks) for the corresponding CDPD traffic. This distribution is irrespective of the total volume, since it relates only to the message sizes involved.

The resulting distribution is shown in Table 8.1-5, independent of the direction.

**Table 8.1-5 CDPD Packet Length Distribution for Non-ITS Data**

Packet Length (RS-blocks)	1	2	3	4	5
Distribution	58.848%	19.616%	13.077%	5.517%	2.942%

We must note here that whereas the distribution may be the same, the actual traffic (volume) in each direction will not be. This will be discussed in detail for each scenario under consideration.

## 8.1.5 CDPD Data Loads

### 8.1.5.1 Urbansville

#### 8.1.5.1.1 2012 Time Frame, ITS Only, Phase I Data Loads

As discussed in Section 8.1.3, the CDPD specification establishes the Reed-Solomon (RS)-block as the quantum of information transmitted in the radio channel. Thus, for the purposes of network performance simulation, the transaction lengths determined during the Data Loading analysis in Phase I had to be converted to the corresponding number of RS-blocks, taking into account the total CDPD protocol overhead.

Tables 8.1-6 through 8.1-13 summarize the data load figures for the 2012 time frame, documenting the required number of RS-blocks per message. The ITS load thus obtained takes into account demographic information on Detroit, Michigan DoT information and GTE Mobilnet market analysis. Note that in Table 8.1-9, corresponding to the ITS traffic associated with emergency vehicles, messages with length greater than 6 blocks were split into packets of at most 4 blocks, the industry consensus for optimum (in terms of delay/throughput performance) number of blocks per packet.

From Table 8.1-13, it is clear that most of the data load is generated by Local Fleet Commercial Vehicles, Private Vehicles, and Probe Vehicles. As expected, the forward link has a somewhat larger data load than the reverse link. Note that on the forward link, where there is no contention for channel access, there is no problem in accommodating the data load – the average channel occupancy is only 34.8%, i.e., the forward channel will operate far below capacity. This fact allows for reducing, as a first-cut, the delay in the forward link to queuing delay. As for the reverse channel, due to the inherent contention mechanism, only simulation can provide the necessary delay/throughput information.

It is noteworthy that the penetration values used in Tables 8.1-6 through 8.1-13 are different (i.e., higher) than those defined in the *Market Bundles/Packages Description* Blue Book. These “optimistic” values result obviously in upper-bound, worst case data loads relative to what is realistic to expect. However, this margin can compensate both for the anticipated inclusion of additional messages resulting from the refinement of the services definition, and any unanticipated acceptance “take-off” for the 20-year time frame.

**Table 8.1-6 Private Vehicles Data Load for the Year 2012—Projected Penetration**

Private Vehicles - Peak period, 20 year time frame														
Number of potential users:	575654	Peak Period: 6-9am & 4-7pm												
Penetration:	20%	21600	Forward		Reverse		Forward Link				Reverse Link			
name	fbits	rbits	# blocks	# blocks	freq	Forward	Reverse	2	3	4	2	3	4	
Estimate Absolute Position	80	16	2	2	1.4	2.8	2.8	2.8	0	0	2.8	0	0	
Provide Current Position	112	48	2	2	0.0038	0.0076	0.0076	0.0076	0	0	0.0076	0	0	
Generate Route Plan	144	112	2	2	1.4	2.8	2.8	2.8	0	0	2.8	0	0	
Generate Route Plan	260	80	3	2	1.4	4.2	2.8	0	4.2	0	2.8	0	0	
Generate Route Plan	354		3	2	1.4	4.2	2.8	0	4.2	0	2.8	0	0	
Generate Route Plan	454	48	3	2	0.2	0.6	0.4	0	0.6	0	0.4	0	0	
Generate Route Plan		128	2	2	1.4	2.8	2.8	2.8	0	0	2.8	0	0	
Generate Route Plan		146	2	2	0.2	0.4	0.4	0.4	0	0	0.4	0	0	
Generate Route Plan	392		3	2	1.4	4.2	2.8	0	4.2	0	2.8	0	0	
Generate Route Plan	392		3	2	1.4	4.2	2.8	0	4.2	0	2.8	0	0	
Generate Route Plan	368		3	2	1.4	4.2	2.8	0	4.2	0	2.8	0	0	
Generate Route Plan		212	2	2	1.4	2.8	2.8	2.8	0	0	2.8	0	0	
Select Potential Routes	656	128	4	2	0.2	0.8	0.4	0	0	0.8	0.4	0	0	
Access Congestion Data and A	392		3	2	2	6	4	0	6	0	4	0	0	
Log Route Plan		390	2	3	0.6	1.2	1.8	1.2	0	0	0	1.8	0	
Log Route Plan	312		3	2	0.6	1.8	1.2	0	1.8	0	1.2	0	0	
Service Driver Requests		144	2	2	4	8	8	8	0	0	8	0	0	
Service Driver Requests	160		2	2	2	4	4	4	0	0	4	0	0	
Service Driver Requests	240		3	2	2	6	4	0	6	0	4	0	0	
Service Driver Requests	88		2	2	2	4	4	4	0	0	4	0	0	
Service Driver Requests	122	128	2	2	0.2	0.4	0.4	0.4	0	0	0.4	0	0	
Service Driver Requests	160	208	2	2	0.2	0.4	0.4	0.4	0	0	0.4	0	0	
Service Driver Requests	656	128	4	2	0.2	0.8	0.4	0	0	0.8	0.4	0	0	
Service Driver Requests	146	112	2	2	2	4	4	4	0	0	4	0	0	
Service Driver Requests	392	112	3	2	2	6	4	0	6	0	4	0	0	
Service Driver Requests	464	146	3	2	0.2	0.6	0.4	0	0.6	0	0.4	0	0	
Improve Driver Roadway Perce	80		2	2	4	8	8	8	0	0	8	0	0	
Collect Roadway Conditions	48	48	2	2	4	8	8	8	0	0	8	0	0	
Perform Vehicle Check In		576	2	4	2	4	8	4	0	0	0	0	8	
Support Manually Initiated Assistance Rec		294	2	3	0.0057	0.0114	0.0171	0.0114	0	0	0	0.0171	0	
Formulate MAYDAY Message		216	2	2	0.00285	0.0057	0.0057	0.0057	0	0	0.0057	0	0	
Generate Toll Billing Request	56	48	2	2	0.0038	0.0076	0.0076	0.0076	0	0	0.0076	0	0	
Generate Parking Billing Reque	52	48	2	2	0.2	0.4	0.4	0.4	0	0	0.4	0	0	
Generate Parking Billing Request		256	2	3	0.2	0.4	0.6	0.4	0	0	0	0.6	0	
			Total # Blocks/User during Peak Period			98.0323	88.038	54.4323	42	1.6	77.6209	2.4171	8	
			Total # Blocks during Peak Period			11286537	10135885	6266834	4835494	184209.3	8936556	278282.7	921046.4	
			Total # Blocks/s during Peak Period			522.5249	469.254	290.1312	223.8654	8.528207	413.7295	12.88346	42.64104	

**Table 8.1-7 Long-Haul Freight and Fleet Vehicles Data Load for the Year 2012**

<b>Commercial Vehicle - Long Haul, peak period, 20 year time frame</b>													
Number of potential users:	7802 Peak Period: 6am-6pm												
Penetration:	100%	43200	Forward	Reverse									
name	fbits	rbits	# blocks	# blocks	freq	Forward	Reverse	Forward Link			Reverse Link		
								2	3	4	2	3	4
Disseminate On Board Safety Status		544	2	4	1	2	4	2	0	0	0	0	4
Disseminate On Board Safety Status		240	2	3	0.668	1.336	2.004	1.336	0	0	0	2.004	0
Disseminate On Board Safety Status		146	2	2	36	72	72	72	0	0	72	0	0
Disseminate On Board Safety Status		322	2	3	0.268	0.536	0.804	0.536	0	0	0	0.804	0
Disseminate On Board Safety Status		146	2	2	0.167	0.334	0.334	0.334	0	0	0.334	0	0
Detect Border Crossing	48		2	2	4	8	8	8	0	0	8	0	0
Automatically Log Mileage and Fuel Use		96	2	2	4	8	8	8	0	0	8	0	0
Estimate Absolute Position	80	16	2	2	12	24	24	24	0	0	24	0	0
Provide Current Position	112	48	2	2	4	8	8	8	0	0	8	0	0
Generate Route Plan	144	112	2	2	1.8	3.6	3.6	3.6	0	0	3.6	0	0
Generate Route Plan	260	80	3	2	1.8	5.4	3.6	0	5.4	0	3.6	0	0
Generate Route Plan	354		3	2	4.2	12.6	8.4	0	12.6	0	8.4	0	0
Generate Route Plan		128	2	2	4.2	8.4	8.4	8.4	0	0	8.4	0	0
Generate Route Plan	352		3	2	4.2	12.6	8.4	0	12.6	0	8.4	0	0
Generate Route Plan	392		3	2	4.2	12.6	8.4	0	12.6	0	8.4	0	0
Generate Route Plan	392		3	2	4.2	12.6	8.4	0	12.6	0	8.4	0	0
Generate Route Plan	368		3	2	4.2	12.6	8.4	0	12.6	0	8.4	0	0
Select Potential Routes		216	2	2	4.2	8.4	8.4	8.4	0	0	8.4	0	0
Select Potential Routes	656	128	4	2	0.15	0.6	0.3	0	0	0.6	0.3	0	0
Access Congestion Data and A	392		3	2	3	9	6	0	9	0	6	0	0
Log Route Plan		390	2	3	0.9	1.8	2.7	1.8	0	0	0	2.7	0
Log Route Plan	312		3	2	0.9	2.7	1.8	0	2.7	0	1.8	0	0
Formulate Route Guidance	392		3	2	3	9	6	0	9	0	6	0	0
Service Driver Requests		144	2	2	16	32	32	32	0	0	32	0	0
Service Driver Requests	160		2	2	6	12	12	12	0	0	12	0	0
Service Driver Requests	392		3	2	2.1	6.3	4.2	0	6.3	0	4.2	0	0
Service Driver Requests	88		2	2	12	24	24	24	0	0	24	0	0
Service Driver Requests	160	208	2	2	3	6	6	6	0	0	6	0	0
Service Driver Requests	146	112	2	2	4	8	8	8	0	0	8	0	0
Service Driver Requests	392	112	3	2	6	18	12	0	18	0	12	0	0
Service Driver Requests		128	2	2	0.9	1.8	1.8	1.8	0	0	1.8	0	0
Disseminate On Board Safety Status		240	2	3	0.668	1.336	2.004	1.336	0	0	0	2.004	0
Improve Driver Roadway Perce	80		2	2	6	12	12	12	0	0	12	0	0
Collect Roadway Conditions	48	48	2	2	6	12	12	12	0	0	12	0	0
Support Manually Initiated Assistance Req	294		2	3	0.045	0.09	0.135	0.09	0	0	0	0.135	0
Formulate MAYDAY Message		216	2	2	0.023	0.046	0.046	0.046	0	0	0.046	0	0
Generate Toll Billing Request	56	48	2	2	1	2	2	2	0	0	2	0	0
			Total # Blocks/User during Peak Period			369.542	335.946	255.542	113.4	0.6	324.434	7.512	4
			Total # Blocks during Peak Period			2883167	2621051	1993739	884746.8	4681.2	2531234	58608.62	31208
			Total # Blocks/s during Peak Period			66.73997	60.67247	46.15136	20.48025	0.108361	58.59338	1.356681	0.722407



**Table 8.1-8 Local Freight and Fleet Vehicles Data Load for the Year 2012**

Commercial Vehicle - Local, peak period, 20 year time frame													
Number of potential users:	109182	Peak Period: 6am-6pm											
Penetration:	60%	43200	Forward	Reverse								Forward Link	Reverse Link
name	fbits	rbits	# blocks	# blocks	freq	Forward	Reverse	2	3	4	2	3	4
Disseminate On Board Safety Status	544		2	4	1	2	4	2	0	0	0	0	4
Disseminate On Board Safety Status	240		2	3	0.668	1.336	2.004	1.336	0	0	0	2.004	0
Disseminate On Board Safety Status	146		2	2	36	72	72	72	0	0	72	0	0
Disseminate On Board Safety Status	322		2	3	0.268	0.536	0.804	0.536	0	0	0	0.804	0
Disseminate On Board Safety Status	146		2	2	0.167	0.334	0.334	0.334	0	0	0.334	0	0
Detect Border Crossing	48		2	2	1	2	2	2	0	0	2	0	0
Automatically Log Mileage and Fuel Use	96		2	2	1	2	2	2	0	0	2	0	0
Estimate Absolute Position	80	16	2	2	12	24	24	24	0	0	24	0	0
Provide Current Position	112	48	2	2	0.804	1.608	1.608	1.608	0	0	1.608	0	0
Generate Route Plan	144	112	2	2	3.6	7.2	7.2	7.2	0	0	7.2	0	0
Generate Route Plan	260	80	3	2	3.6	10.8	7.2	0	10.8	0	7.2	0	0
Generate Route Plan	354		3	2	8.4	25.2	16.8	0	25.2	0	16.8	0	0
Generate Route Plan		128	2	2	8.4	16.8	16.8	16.8	0	0	16.8	0	0
Generate Route Plan	352		3	2	8.4	25.2	16.8	0	25.2	0	16.8	0	0
Generate Route Plan	392		3	2	8.4	25.2	16.8	0	25.2	0	16.8	0	0
Generate Route Plan	392		3	2	8.4	25.2	16.8	0	25.2	0	16.8	0	0
Generate Route Plan	368		3	2	8.4	25.2	16.8	0	25.2	0	16.8	0	0
Select Potential Routes		216	2	2	8.4	16.8	16.8	16.8	0	0	16.8	0	0
Select Potential Routes	656	128	4	2	0.3	1.2	0.6	0	0	1.2	0.6	0	0
Access Congestion Data and A	392		3	2	6	18	12	0	18	0	12	0	0
Log Route Plan		390	2	3	3.6	7.2	10.8	7.2	0	0	0	10.8	0
Log Route Plan	312		3	2	3.6	10.8	7.2	0	10.8	0	7.2	0	0
Service Driver Requests		144	2	2	39	78	78	78	0	0	78	0	0
Service Driver Requests	160		2	2	12	24	24	24	0	0	24	0	0
Service Driver Requests	392		3	2	4.2	12.6	8.4	0	12.6	0	8.4	0	0
Service Driver Requests	88		2	2	12	24	24	24	0	0	24	0	0
Service Driver Requests	122	128	2	2	1	2	2	2	0	0	2	0	0
Service Driver Requests	160	208	2	2	6	12	12	12	0	0	12	0	0
Service Driver Requests	656	128	4	2	1	4	2	0	0	4	2	0	0
Service Driver Requests	146	112	2	2	2	4	4	4	0	0	4	0	0
Service Driver Requests	392	112	3	2	12	36	24	0	36	0	24	0	0
Service Driver Requests		128	2	2	6	12	12	12	0	0	12	0	0
Disseminate On Board Safety Status		240	2	3	2.4	4.8	7.2	4.8	0	0	0	7.2	0
Improve Driver Roadway Perce	80		2	2	4	8	8	8	0	0	8	0	0
Collect Roadway Conditions	48	48	2	2	6	12	12	12	0	0	12	0	0
Support Manually Initiated Assistance Req	294		2	3	0.045	0.09	0.135	0.09	0	0	0	0.135	0
Formulate MAYDAY Message	216		2	2	0.023	0.046	0.046	0.046	0	0	0.046	0	0
Generate Toll Billing Request	56	48	2	2	0.0038	0.0076	0.0076	0.0076	0	0	0.0076	0	0
Generate Parking Billing Reque	52	48	2	2	0.1	0.2	0.2	0.2	0	0	0.2	0	0
Generate Parking Billing Request		256	2	3	0.2	0.4	0.6	0.4	0	0	0	0.6	0
			Total # Blocks/User during Peak Period			542.014	476.95	322.614	214.2	5.2	452.142	20.808	4
			Total # Blocks during Peak Period			35506904	31244613	21134185	14032071	340647.8	29619461	1363115	262036.8
			Total # Blocks/s during Peak Period			821.9191	723.2549	489.2172	324.8165	7.885367	685.6357	31.5536	6.065667

**Table 8.1-9 Emergency Vehicles Data Load for the Year 2012**

Emergency Vehicle, peak period, 20 year time frame														
Number of potential users:	3305	Peak Period: 6am-7pm												
Penetration:	100%	46800	Forward	Reverse					Forward Link			Reverse Link		
name	fbits	rbits	# blocks	# blocks	freq	Forward	Reverse	2	3	4	2	3	4	
Present Dispatch Instructions T	2708		12	2	26		52				52	0	0	
			4		78	312		0	0	312				
Estimate Absolute Position	80	16	2	2	13	26	26	26	0	0	26	0	0	
Generate Route Plan	160	112	2	2	2	4	4	4	0	0	4	0	0	
Generate Route Plan	260	80	3	2	2	6	4	0	6	0	4	0	0	
Select Potential Routes	656	128	4	2	0.045	0.18	0.09	0	0	0.18	0.09	0	0	
Access Congestion Data and A	392		3	2	2	6	4	0	6	0	4	0	0	
Log Route Plan	312		3	2	2	6	4	0	6	0	4	0	0	
Service Driver Requests		144	2	2	6.2	12.4	12.4	12.4	0	0	12.4	0	0	
Service Driver Requests	160		2	2	2	4	4	4	0	0	4	0	0	
Service Driver Requests	88		2	2	12	24	24	24	0	0	24	0	0	
Service Driver Requests	160	208	2	2	0.2	0.4	0.4	0.4	0	0	0.4	0	0	
Service Driver Requests	146	112	2	2	2	4	4	4	0	0	4	0	0	
Service Driver Requests	392	112	3	2	2	6	4	0	6	0	4	0	0	
Disseminate Vehicle and Driver Safety Sta		112	2	2	4	8	8	8	0	0	8	0	0	
Improve Driver Roadway Percd	80	40	2	2	4	8	8	8	0	0	8	0	0	
Support Manually Initiated Assistance Req		294	2	3	0.0019	0.0038	0.0057	0.0038	0	0	0	0.0057	0	
Formulate MAYDAY Message		216	2	2	0.0019	0.0038	0.0038	0.0038	0	0	0.0038	0	0	
Communicate Emergency Status		374	2	3	52	104	156	104	0	0	0	156	0	
Maintain Emergency Vehicle Status		208	2	2	2	4	4	4	0	0	4	0	0	
Maintain Emergency Vehicle Status		274	2	3	26	52	78	52	0	0	0	78	0	
Maintain Emergency Vehicle Status		216	2	2	52	104	104	104	0	0	104	0	0	
Determine Best Vehicle Routes		392	2	3	13	26	39	26	0	0	0	39	0	
Monitor Emergency Status		1376	2	7	7	14		14	0	0	0	0	0	
				4	7		28				0	0	28	
				3	7		21				0	21	0	
Manage Vehicle Dispatch		2708	2	12	6	12		12	0	0	0	0	0	
				4	18		72	0	0	0	0	0	72	
			Total # Blocks/User during Peak Period			742.9876	660.8995	406.8076	24	312.18	266.8938	294.0057	100	
			Total # Blocks during Peak Period			2455574	2184273	1344499	79320	1031755	882084	971688.8	330500	
			Total # Blocks/s during Peak Period			52.46953	46.6725	28.72861	1.694872	22.04604	18.84795	20.76258	7.061966	

**Table 8.1-10 Public Transportation Services Data Load for the Year 2012**

Transit Vehicle, peak period, 20 year time frame															
Number of potential users:	1789	Peak Period: 6am-7pm													
Penetration:	100%	46800	Forward	Reverse											
name	fbits	rbits	# blocks	# blocks	freq	Forward	Reverse	Forward Link					Reverse Link		
								2	3	4	5	2	3	4	
Real Time Information Dissemi	656		4	2	26	104	52	0	0	104	0	52	0	0	
Real Time Information Dissemi	200		2	2	52	104	104	104	0	0	0	104	0	0	
Real Time Information Dissemi	392		3	2	52	156	104	0	156	0	0	104	0	0	
Real Time Information Dissemi	656		4	2	52	208	104	0	0	208	0	104	0	0	
Real Time Information Dissemi	144		2	2	13	26	26	26	0	0	0	26	0	0	
Report Traffic Information	392		3	2	13	39	26	0	39	0	0	26	0	0	
Report Traffic Information		272	2	3	13	26	39	26	0	0	0	0	39	0	
Report Traffic Information	1000		5	2	7	35	14	0	0	0	35	14	0	0	
Report Vehicle Position Information		48	2	2	78	156	156	156	0	0	0	156	0	0	
Report Transit Request Information		160	2	2	13	26	26	26	0	0	0	26	0	0	
Report Transit Request Informa	122		2	2	13	26	26	26	0	0	0	26	0	0	
Report Transit Request Informa	160		2	2	13	26	26	26	0	0	0	26	0	0	
Monitor Transit Schedule Adhe	24		2	2	13	26	26	26	0	0	0	26	0	0	
Assess Driver Performance		528	2	4	2	4	8	4	0	0	0	0	0	8	
Monitor Transit Vehicle Condition		400	2	3	6.24	12.48	18.72	12.48	0	0	0	0	18.72	0	
Monitor Transit Vehicle Condition		48	2	2	6.24	12.48	12.48	12.48	0	0	0	12.48	0	0	
Report Passenger Information		160	2	2	26	52	52	52	0	0	0	52	0	0	
Report Passenger Information	1016		5	2	26	130	52	0	0	0	130	52	0	0	
Generate Passenger Fare And Loading Sta	160		2	2	78	156	156	156	0	0	0	156	0	0	
Generate Transit Fare Billing Request	176		2	2	13	26	26	26	0	0	0	26	0	0	
Generate Transit Fare Billing Request		260	2	3	100	200	300	200	0	0	0	0	300	0	
Control Passenger Access	88		2	2	100	200	200	200	0	0	0	200	0	0	
Log Route Plan	312		3	2	26	78	52	0	78	0	0	52	0	0	
Service Driver Requests		146	2	2	65	130	130	130	0	0	0	130	0	0	
Service Driver Requests	336		3	2	52	156	104	0	156	0	0	104	0	0	
Service Driver Requests	88		2	2	13	26	26	26	0	0	0	26	0	0	
Service Driver Requests	122	128	2	2	13	26	26	26	0	0	0	26	0	0	
Service Driver Requests	160	208	2	2	13	26	26	26	0	0	0	26	0	0	
Service Driver Requests		176	2	2	2	4	4	4	0	0	0	4	0	0	
Improve Driver Roadway Perce	80		2	2	4	8	8	8	0	0	0	8	0	0	
Determine Longitudinal Collisio	48		2	2	2	4	4	4	0	0	0	4	0	0	
Collect Roadway Conditions	48	48	2	2	4	8	8	8	0	0	0	8	0	0	
Regulate Lateral Vehicle Contr	18	20	2	2	4	8	8	8	0	0	0	8	0	0	
Support Manually Initiated Assistance Req		294	2	3	0.2	0.4	0.6	0.4	0	0	0	0	0.6	0	
Formulate MAYDAY Message		216	2	2	0.1	0.2	0.2	0.2	0	0	0	0.2	0	0	
Generate Toll Billing Request	56	48	2	2	0.0038	0.0076	0.0076	0.0076	0	0	0	0.0076	0	0	
			Total # Blocks/User during Peak Period			2225.568	1951.008	1319.568	429	312	165	1584.688	358.32	8	
			Total # Blocks during Peak Period			3981540	3490353	2360706	767481	558168	295185	2835006	641034.5	14312	
			Total # Blocks/s during Peak Period			85.07565	74.58018	50.44245	16.39917	11.92667	6.307372	60.57705	13.69732	0.305812	

**Table 8.1-11 Traveler Information Services Data Load for the Year 2012**

<b>Traveler Information, peak period, 20 year time frame</b>													
Number of potential users:	57858		Peak Period: 6-9am & 4-7pm										
Penetration:	20%	21600	Forward	Reverse					Forward Link			Reverse Link	
<b>name</b>	<b>fbits</b>	<b>rbits</b>	<b># blocks</b>	<b># blocks</b>	<b>freq</b>	<b>Forward</b>	<b>Reverse</b>		<b>2</b>	<b>3</b>	<b>4</b>	<b>2</b>	<b>3</b>
Reconcile Estimated Position w	24		2	2	0.045	0.09	0.09		0.09	0	0	0.09	0
Reconcile Estimated Position w	48		2	2	0.045	0.09	0.09		0.09	0	0	0.09	0
Select Potential Routes		216	2	2	2.2	4.4	4.4		4.4	0	0	4.4	0
Select Potential Routes	656		4	2	2	8	4		0	0	8	4	0
Select Potential Routes	352		3	2	0.2	0.6	0.4		0	0.6	0	0.4	0
Access Congestion Data and A	392		3	2	1	3	2		0	3	0	2	0
Access Congestion Data and A	160		2	2	2	4	4		4	0	0	4	0
Access Congestion Data and A	240		3	2	1	3	2		0	3	0	2	0
Access Congestion Data and A	392		3	2	0.1	0.3	0.2		0	0.3	0	0.2	0
Access Congestion Data and A	392		3	2	0.2	0.6	0.4		0	0.6	0	0.4	0
Format Traveler Information Request		228	2	2	4.3	8.6	8.6		8.6	0	0	8.6	0
Support Manually Initiated Assistance Req		296	2	3	0.0057	0.0114	0.0171		0.0114	0	0	0	0.0171
Transmit MAYDAY Message		216	2	2	0.0057	0.0114	0.0114		0.0114	0	0	0.0114	0
			<b>Total # Blocks/User during Peak Period</b>			<b>32.7028</b>	<b>26.2085</b>		<b>17.2028</b>	<b>7.5</b>	<b>8</b>	<b>26.1914</b>	<b>0.0171</b>
			<b>Total # Blocks during Peak Period</b>			<b>378423.7</b>	<b>303274.3</b>		<b>199063.9</b>	<b>86787</b>	<b>92572.8</b>	<b>303076.4</b>	<b>197.8744</b>
			<b>Total # Blocks/s during Peak Period</b>			<b>17.51962</b>	<b>14.04048</b>		<b>9.215922</b>	<b>4.017917</b>	<b>4.285778</b>	<b>14.03132</b>	<b>0.009161</b>

**Table 8.1-12 Probe Vehicles Data Load for the Year 2012**

<b>Traffic Management: Probes, peak period, 20 year time frame</b>										
Number of potential users:	7704	Peak Period: 6-9am & 4-7pm								
Penetration:	100%	21600	Forward	Reverse				Forward	Reverse	
<b>name</b>	<b>fbits</b>	<b>rbits</b>	<b># blocks</b>	<b># blocks</b>	<b>freq</b>	Forward	Reverse	<b>2</b>	<b>2</b>	<b>3</b>
Probe Trip Notice		464	2	3	2	4	6	4	0	6
Probe Trip Accept	64		2	2	2	4	4	4	4	0
Probe Report		106	2	2	360	720	720	720	720	0
		<b>Total # Blocks/User during Peak Period</b>				<b>728</b>	<b>730</b>	<b>728</b>	<b>724</b>	<b>6</b>
		<b>Total # Blocks during Peak Period</b>				<b>5608512</b>	<b>5623920</b>	<b>5608512</b>	<b>5577696</b>	<b>46224</b>
		<b>Total # Blocks/s during Peak Period</b>				<b>259.6533</b>	<b>260.3667</b>	<b>259.6533</b>	<b>258.2267</b>	<b>2.14</b>

**Table 8.1-13 Overall ITS Data Load Summary for the Year 2012**

Peak period, 20 year time frame			Forward Link				Reverse Link		
<b>Services/Users Groupings</b>	Forward	Reverse	<b>2</b>	<b>3</b>	<b>4</b>	<b>5</b>	<b>2</b>	<b>3</b>	<b>4</b>
<b>Transit Vehicles</b>	85.08	74.58	50.44	16.40	11.93	6.31	60.58	13.70	0.31
<b>Traveler Information</b>	17.52	14.04	9.22	4.02	4.29		14.03	0.01	
<b>Traffic Management: Probes</b>	259.65	260.37	259.65				258.23	2.14	
<b>Private Vehicles</b>	522.52	469.25	290.13	223.87	8.53		413.73	12.88	42.64
<b>Emergency Vehicles</b>	52.47	46.67	28.73	1.69	22.05		18.85	20.76	7.06
<b>Commercial Vehicles - Long Haul</b>	66.74	60.67	46.15	20.48	0.11		58.59	1.36	0.72
<b>Commercial Vehicles - Local</b>	821.92	723.25	489.22	324.82	7.89		685.64	31.55	6.07
TOTAL # Blocks/s	1825.90	1648.84	1173.54	591.27	54.78	6.31	1509.64	82.40	56.80
TOTAL # Blocks/s/sector	16.01668	14.46352							
Channel Utilization	34.8%	31.4%							
Packet Length Distribution			64.3%	32.4%	3.0%	0.3%	91.6%	5.0%	3.4%

### 8.1.5.1.2 2002 Time Frame, Phase II Data Loads

#### 8.1.5.1.2.1 ITS Only

Table 8.1-14 through Table 8.1-21 summarize the data load figures for the 2002 time frame, and document the required number of RS-blocks per message.

Two facts should be noted. First, the penetration values used in Table 8.1-14 through Table 8.1-21 are those defined in the *Evaluatory Design* document. However, in order to upper-bound, and thus get a worst case CDPD traffic, we assumed that even if there is a competing technology to carry a given message, all the load would be carried over CDPD. As an example, for the traffic between the PIAS and the ISP, which can either be wireless or wireline, as a worst case assumption, we assumed all of it going over CDPD. Again, we think this margin is necessary to compensate both for the anticipated inclusion of additional messages resulting from the refinement of the services definition, and any unanticipated acceptance “take-off.”

Second, in spite of the use of worst case traffic, the overall data loads shown in summary Table 8.1-21 are still lower than the ones of Phase I, corresponding to Urbansville 2012. This reflects not only a more conservative approach to ITS service acceptance and adoption rates, but mainly the fact that we are now looking at the 2002 time frame instead, where the penetration figures are naturally lower.

Table 8.1-14 Private Vehicles CDPD Traffic for the Year 2002														Table 8.1-14 Private Vehicles CDPD Traffic for the Year 2002				
<b>Private Vehicle</b>																		
Number of users:		828,947																
Peak Period: 6-9am & 4-7pm		21600 seconds																
PA Source	PA Sink	Penetration	Frequency	Forward bits	Reverse bits	Forward bytes	Reverse bytes	Forward # blocks	Reverse # blocks	Frequency* Penetration	Forward blocks	Reverse blocks	Forward Link	1	2	3	4	
EM	VS	10%	0.0001	26	0	6	0	2	0	0.0001	0.0002	0	0	0.0002	0	0	0	
EM	VS	10%	0.0001	26	0	6	0	2	0	0.0001	0.0002	0	0	0.0002	0	0	0	
ISP	VS	10%	0.0001	234	0	32	0	3	0	0.0001	0.0003	0	0	0	0.0003	0	0	
ISP	VS	10%	0.0001	234	0	32	0	3	0	0.0001	0.0003	0	0	0	0.0003	0	0	
ISP	VS	10%	0.1	6146	0	771	0	24	0	0.1	2.4	0	0	0	0	0	0	
ISP	VS							<34333+22222>						1	1.2	0.4		
ISP	VS	10%	0.01	10802	0	1353	0	41	0	0.01	0.41	0	0	0	0	0	0	
ISP	VS							<2*34333+4332>						0.02	0.3	0.12		
LocData	VS	7%	0.007	146	0	21	0	2	0	0.007	0.014	0	0	0.014	0	0	0	
PayInstr	VS	10%	0.0001	178	0	25	0	3	0	0.0001	0.0003	0	0	0	0.0003	0	0	
PayInstr	VS	100%	0.0001	178	0	25	0	3	0	0.0001	0.0003	0	0	0	0.0003	0	0	
VS	EM	10%	0.0001	0	282	0	38	0	3	0.0001	0	0.0003	0	0	0	0	0	
VS	EM	10%	0.0001	0	3354	0	422	0	14	0.0001	0	0.0014	0	0	0	0	0	
VS	EM							<333222>										
VS	ISP	10%	0.0001	0	632.4	0	82	0	4	0.0001	0	0.0004	0	0	0	0	0	
VS	ISP	10%	0.0001	0	642	0	83	0	4	0.0001	0	0.0004	0	0	0	0	0	
VS	ISP	10%	0.1	0	290	0	39	0	3	0.1	0	0.3	0	0	0	0	0	
VS	ISP	7%	0.14	0	34	0	7	0	2	0.035	0	0.07	0	0	0	0	0	
VS	ISP	10%	0.01	0	674	0	87	0	4	0.01	0	0.04	0	0	0	0	0	
VS	PayInstr	10%	0.0001	0	50	0	9	0	2	0.0001	0	0.0002	0	0	0	0	0	
VS	PMS	10%	0.00005	0	514	0	67	0	4	0.0001	0	0.0004	0	0	0	0	0	
VS	PMS	10%	0.00005	0	26	0	6	0	2	0.0001	0	0.0002	0	0	0	0	0	
Total # blocks/User during peak period													0	1.0344	1.5012	0.52		
*Population													0	857463	1244416	431052.6		
/peak period duration													0	39.69736	57.61183	19.95614		
/per sector													0	0.172597	0.250486	0.086766		
packets/s													44.042	5.611	0.00000	19.84868	19.20394	4.98903
													0.0%	45.1%	43.6%	11.3%		

Table 8.1-14 Private Vehicles CDPD Traffic for the Year 2002



Table 8.1-15 Long-Haul Freight and Fleet Vehicles CDPD Traffic for the Year 2002														Table 8.1-15 Long-Haul Freight and Fleet Ve			
CVO Long Haul																	
Number of users:		6,397															
Peak Period: 6am-6pm		43200 seconds															
PA Source	PA Sink	Penetration	Frequency	Forward bits	Reverse bits	Forward bytes	Reverse bytes	Forward # blocks	Reverse # blocks	Frequency*	Forward blocks	Reverse blocks	Forward Link	1	2	3	4
CVAS	CVCS	50%	5E-05	482	0	63	0	4	0	0.0005	0.002	0	0	0	0	0	0.002
CVAS	CVCS	50%	0.005	410	0	54	0	3	0	0.05	0.15	0	0	0	0	0.15	0
CVAS	CVCS	100%	0.001	410	0	54	0	3	0	0.01	0.03	0	0	0	0	0.03	0
CVAS	CVCS	100%	0.001	410	0	54	0	3	0	0.01	0.03	0	0	0	0	0.03	0
CVAS	FMS	50%	0.05	26	0	6	0	2	0	0.5	1	0	0	1	0	0	0
CVAS	FMS	50%	0.025	3818	0	480	0	16	0	0.25	4	0	0	0	0	0	0
CVAS	FMS							<34333+2>							0.5	3	1
CVAS	FMS	50%	0.05	170	0	24	0	3	0	0.5	1.5	0	0	0	0	1.5	0
CVAS	FMS	50%	0.025	3818	0	480	0	16	0	0.25	4	0	0	0	0	0	0
CVAS	FMS							<34333+2>							0.5	3	1
CVAS	FMS	50%	0.05	346	0	46	0	3	0	0.5	1.5	0	0	0	0	1.5	0
CVCS	CVAS	50%	0.005	0	554	0	72	0	4	0.05	0	0.2	0	0	0	0	0
CVCS	CVAS	50%	0.0005	0	3362	0	423	0	14	0.005	0	0.07	0	0	0	0	0
CVCS	CVAS							<33322>									
CVCS	CVAS	100%	0.01	0	554	0	72	0	4	0.1	0	0.4	0	0	0	0	0
CVCS	CVAS	100%	0.001	0	538	0	70	0	4	0.01	0	0.04	0	0	0	0	0
CVS	FMS	50%	0.5	0	154	0	22	0	2	0.5	0	1	0	0	0	0	0
CVS	FMS	50%	0.5	0	330	0	44	0	3	0.5	0	1.5	0	0	0	0	0
CVS	FMS	50%	0.5	0	98	0	15	0	2	0.5	0	1	0	0	0	0	0
CVS	FMS	50%	1	0	1234	0	157	0	6	1	0	6	0	0	0	0	0
CVS	FMS							<22111>									
CVS	FMS	50%	0.05	0	26	0	6	0	2	0.05	0	0.1	0	0	0	0	0
CVS	FMS	50%	1	0	2066	0	261	0	9	1	0	9	0	0	0	0	0
CVS	FMS							<22222>									
EM	FMS	10%	1E-05	146	0	21	0	2	0	0.0001	0.0002	0	0	0	0.0002	0	0
EM	VS	10%	0.0001	26	0	6	0	2	0	0.0001	0.0002	0	0	0	0.0002	0	0
EM	VS	10%	0.0001	26	0	6	0	2	0	0.0001	0.0002	0	0	0	0.0002	0	0
FMS	CVAS	50%	0.05	0	402	0	53	0	3	0.5	0	1.5	0	0	0	0	0
FMS	CVAS	50%	0.05	0	414	0	54	0	3	0.5	0	1.5	0	0	0	0	0
FMS	CVAS	50%	0.05	0	3498	0	440	0	15	0.5	0	7.5	0	0	0	0	0
FMS	CVAS							<4443>									
FMS	CVAS	50%	0.05	0	414	0	54	0	3	0.5	0	1.5	0	0	0	0	0
FMS	CVAS	50%	0.05	0	3498	0	440	0	15	0.5	0	7.5	0	0	0	0	0
FMS	CVAS							<4443>									
FMS	CVS	50%	0.5	5082	0	638	0	20	0	0.5	10	0	0	0	0	0	0
FMS	CVS							<34333+2211>						1	2	6	2
FMS	CVS	50%	0.25	82	0	13	0	2	0	0.25	0.5	0	0	0	0.5	0	0
FMS	CVS	50%	0.5	346	0	46	0	3	0	0.5	1.5	0	0	0	0	1.5	0
FMS	CVS	50%	1	3042	0	383	0	13	0	1	13	0	0	0	0	0	0
FMS	CVS							<1/2*355+1/2*522221>						0.5	4	1.5	
FMS	CVS	50%	1	1226	0	156	0	6	0	1	6	0	0	0	0	0	0
FMS	CVS							<1/2*33+1/2*22111>						1.5	2	3	
FMS	EM	10%	1E-05	0	3754	0	472	0	16	0.0001	0	0.0016	0	0	0	0	0
FMS	EM							<34333+2>									
FMS	EM	10%	1E-05	0	242	0	33	0	3	0.0001	0	0.0003	0	0	0	0	0
FMS	ImFrghD	50%	0.005	0	530	0	69	0	4	0.05	0	0.2	0	0	0	0	0
FMS	ImFrghS	50%	0.005	0	530	0	69	0	4	0.05	0	0.2	0	0	0	0	0
FMS	ISP	50%	0.05	0	1234	0	157	0	6	0.5	0	3	0	0	0	0	0
FMS	ISP							<22111>									
FMS	ISP	50%	0.1	0	1354	0	172	0	7	1	0	7	0	0	0	0	0
FMS	ISP							<421>									
FMS	PayInstr	50%	0.05	0	50	0	9	0	2	0.5	0	1	0	0	0	0	0
ImFrghD	FMS	50%	0.005	530	0	69	0	4	0	0.05	0.2	0	0	0	0	0	0.2
ImFrghS	FMS	50%	0.005	530	0	69	0	4	0	0.05	0.2	0	0	0	0	0	0.2
ISP	FMS	50%	0.05	3034	0	382	0	13	0	0.5	6.5	0	0	0	0	0	0
ISP	FMS							<522221>						0.5	4		
ISP	FMS	50%	0.1	3154	0	397	0	13	0	1	13	0	0	0	0	0	0
ISP	FMS							<43322>								6	4
ISP	VS	10%	0.0001	234	0	32	0	3	0	0.0001	0.0003	0	0	0	0	0.0003	0
ISP	VS	10%	0.0001	234	0	32	0	3	0	0.0001	0.0003	0	0	0	0	0.0003	0
ISP	VS	10%	0.1	6146	0	771	0	24	0	0.1	2.4	0	0	0	0	0	0
ISP	VS							<34333+22222>							1	1.2	0.4
ISP	VS	10%	0.01	10802	0	1353	0	41	0	0.01	0.41	0	0	0	0	0	0
ISP	VS							<2*34333+1/2*5322+1/2*4332>							0.03	0.285	0.1
LocData	VS	7%	0.007	146	0	21	0	2	0	0.007	0.014	0	0	0	0.014	0	0
PayInstr	FMS	50%	0.05	114	0	17	0	2	0	0.5	1	0	0	0	1	0	0
PayInstr	VS	10%	0.0001	178	0	25	0	3	0	0.0001	0.0003	0	0	0	0	0.0003	0

Table 8.1-15 Long-Haul Freight and Fleet Vehicles CDPD Traffic for the Year 2002

Table 8.1-16 Local Freight and Fleet Vehicles CDPD Traffic for the Year 2002											Table 8.1-16 Local Freight and Fleet Vehicle						
CVO Local																	
Number of users:		89,565															
Peak Period: 6am-6pm		43200 seconds															
PA Source	PA Sink	Penetration	Frequency	Forward bits	Reverse bits	Forward bytes	Reverse bytes	Forward # blocks	Reverse # blocks	Frequency*	Forward blocks	Reverse blocks	Forward Link	1	2	3	4
CVS	FMS	50%	1	0	154	0	22	0	2	1	0	2	0	0	0	0	0
CVS	FMS	50%	2	0	1234	0	157	0	6	1.5	0	9	0	0	0	0	0
CVS	FMS								<22111>								
CVS	FMS	50%	0.05	0	26	0	6	0	2	0.05	0	0.1	0	0	0	0	0
CVS	FMS	50%	2	0	2066	0	261	0	9	2	0	18	0	0	0	0	0
CVS	FMS								<22222>								
EM	FMS	10%	1E-05	146	0	21	0	2	0	0.0001	0.0002	0	0	0.0002	0	0	0
EM	VS	10%	0.0001	26	0	6	0	2	0	0.0001	0.0002	0	0	0.0002	0	0	0
EM	VS	10%	0.0001	26	0	6	0	2	0	0.0001	0.0002	0	0	0.0002	0	0	0
FMS	CVS	50%	1	5082	0	638	0	20	0	1	20	0	0	0	0	0	0
FMS	CVS								<34333+2211>								
FMS	CVS	50%	2	3042	0	383	0	13	0	2	26	0	0	0	0	0	0
FMS	CVS								<355>								
FMS	CVS	50%	2	1226	0	156	0	6	0	2	12	0	0	0	0	0	0
FMS	CVS								<22111>								
FMS	EM	10%	1E-05	0	3754	0	472	0	16	0.0001	0	0.0016	0	0	0	0	0
FMS	EM								<34333+2>								
FMS	EM	10%	1E-05	0	242	0	33	0	3	0.0001	0	0.0003	0	0	0	0	0
FMS	ImFrghT	50%	0.005	0	530	0	69	0	4	0.05	0	0.2	0	0	0	0	0
FMS	ImFrghS	50%	0.005	0	530	0	69	0	4	0.05	0	0.2	0	0	0	0	0
FMS	ISP	50%	0.1	0	1234	0	157	0	6	1	0	6	0	0	0	0	0
FMS	ISP								<22111>								
FMS	ISP	50%	0.2	0	1354	0	172	0	7	2	0	14	0	0	0	0	0
FMS	ISP								<421>								
ImFrghT	FMS	50%	0.005	530	0	69	0	4	0	0.05	0.2	0	0	0	0	0	0.2
ImFrghS	FMS	50%	0.005	530	0	69	0	4	0	0.05	0.2	0	0	0	0	0	0.2
ISP	FMS	50%	0.1	3034	0	382	0	13	0	1	13	0	0	0	0	0	0
ISP	FMS								<522221>								
ISP	FMS	50%	0.2	3154	0	397	0	13	0	2	26	0	0	0	0	0	0
ISP	FMS								<1/2*43322+1/2*24422>								
ISP	VS	10%	0.0001	234	0	32	0	3	0	0.0001	0.0003	0	0	0	0.0003	0	0
ISP	VS	10%	0.0001	234	0	32	0	3	0	0.0001	0.0003	0	0	0	0.0003	0	0
ISP	VS	10%	0.2	6146	0	771	0	24	0	0.2	4.8	0	0	0	0	0	0
ISP	VS								<34333+22222>								
ISP	VS	10%	0.01	10802	0	1353	0	41	0	0.01	0.41	0	0	0	0	0	0
ISP	VS								<2*34333+5322>								
LocData	VS	7%	0.007	146	0	21	0	2	0	0.007	0.014	0	0	0.014	0	0	0
PayInstr	VS	10%	0.0001	178	0	25	0	3	0	0.0001	0.0003	0	0	0	0.0003	0	0
VS	EM	10%	0.0001	0	282	0	38	0	3	0.0001	0	0.0003	0	0	0	0	0
VS	EM	10%	0.0001	0	3354	0	422	0	14	0.0001	0	0.0014	0	0	0	0	0
VS	EM								<333222>								
VS	ISP	10%	0.0001	0	632.4	0	82	0	4	0.0001	0	0.0004	0	0	0	0	0
VS	ISP	10%	0.0001	0	642	0	83	0	4	0.0001	0	0.0004	0	0	0	0	0
VS	ISP	10%	0.2	0	290	0	39	0	3	0.2	0	0.6	0	0	0	0	0
VS	ISP	10%	0.01	0	674	0	87	0	4	0.01	0	0.04	0	0	0	0	0
VS	PayInstr	10%	0.0001	0	50	0	9	0	2	0.0001	0	0.0002	0	0	0	0	0
VS	PMS	10%	0.00005	0	514	0	67	0	4	0.0001	0	0.0004	0	0	0	0	0
VS	PMS	10%	0.00005	0	26	0	6	0	2	0.0001	0	0.0002	0	0	0	0	0
Total # blocks/User during peak period											9	32.0546	26.6709	17.28			
*Population											806084.1749	2870967	2388777	1547682			
/peak period duration											18.6593559	66.45758	55.29576	35.82596			
/per sector											0.081127634	0.288946	0.240416	0.155765			
packets/s											89.664	61.912	18.65936	33.22879	18.43192	8.95649	
											20.8%	37.1%	20.6%	10.0%			

Table 8.1-16 Local Freight and Fleet Vehicles CDPD Traffic for the Year 2002

Table 8.1-17 Emergency Vehicles CDPD Traffic for the Year 2002											Table 8.1-17 Emergency Vehicles CDPD Traf						
Emergency Vehicle																	
Number of users:		4,850															
Peak Period: 6am-7pm		46800 seconds															
PA Source	PA Sink	Penetration	Frequency	Forward bits	Reverse bits	Forward bytes	Reverse bytes	Forward # blocks	Reverse # blocks	Frequency* Penetration	Forward blocks	Reverse blocks	Forward Link	1	2	3	4
EM	EVS	100%	13	1042	0	133	0	6	0	13	78	0	0	0	0	0	0
EM	EVS							<411>					26				52
EVS	EM	100%	26	0	26	0	6	0	2	26	0	52	0	0	0	0	0
EVS	EM	100%	26	0	146	0	21	0	2	26	0	52	0	0	0	0	0
EVS	EM	100%	13	0	530	0	69	0	4	13	0	52	0	0	0	0	0
Total # blocks/User during peak period											26	0	0	52			
*Population											126093.5221	0	0	252187			
/peak period duration											2.694306027	0	0	5.388612			
/per sector											0.011714374	0	0	0.023429			
packets/s											4.041	6.736	2.69431	0.00000	0.00000	1.34715	
											66.7%	0.0%	0.0%	33.3%			

**Table 8.1-17 Emergency Vehicles CDPD Traffic for the Year 2002**

Table 8.1-18 Transit Vehicles CDPD Traffic for the Year 2002														Table 8.1-18 Transit Vehicles CDPD Traffic			
Transit Vehicles																	
Public_Transit_Vehicles		1466	Peak Period: 6am-7pm		46800	seconds											
ParaTransit_Vehicles		367															
Transit Customers		47,440															
PA Source	PA Sink	Penetration	Frequency	bits	Reverse	bytes	Reverse	# blocks	# blocks	Frequency*	Forward	Reverse	Forward Link	1	2	3	4
ISP	RTS	10%	0.00032	426	0	56	0	3	0	0.003236016	0.00971	0	0	0	0	0.009708	0
ISP	RTS	10%	0.00032	666	0	86	0	4	0	0.003236016	0.01294	0	0	0	0	0.012944	0
ISP	RTS	10%	0.00032	498	0	65	0	4	0	0.003236016	0.01294	0	0	0	0	0.012944	0
ISP	RTS	10%	0.00032	987.68	0	126	0	5	0	0.003236016	0.01618	0	0	0	0	0	0
PayInstr	RTS	10%	0.064	26	0	6	0	2	0	0.647203274	1.29441	0	0	1.294407	0	0	0
PayInstr	RTS	10%	0.00032	178	0	25	0	3	0	0.003236016	0.00971	0	0	0	0	0.009708	0
PayInstr	RTS	10%	0.00032	178	0	25	0	3	0	0.003236016	0.00971	0	0	0	0	0.009708	0
PayInstr	RTS	10%	0.00032	178	0	25	0	3	0	0.003236016	0.00971	0	0	0	0	0.009708	0
PayInstr	TRVS	100%	0.32	26	0	6	0	2	0	32.36016371	64.7203	0	0	64.72033	0	0	0
PayInstr	TRVS	100%	0.032	178	0	25	0	3	0	0.032360164	0.09708	0	0	0	0	0.09708	0
RTS	EM	100%	0.0032	0	370	0	49	0	3	0.032360164	0	0.09708	0	0	0	0	0
RTS	ISP	10%	0.00032	0	738	0	95	0	5	0.003236016	0	0.01618	0	0	0	0	0
RTS	ISP	10%	0.320000005	0	98	0	15	0	2	3.236016371	0	6.47203	0	0	0	0	0
RTS	ISP	10%	0.064000001	0	66	0	11	0	2	0.647203274	0	1.29441	0	0	0	0	0
RTS	ISP	10%	0.320000005	0	58	0	10	0	2	3.236016371	0	6.47203	0	0	0	0	0
RTS	ISP	10%	0.00032	0	978	0	125	0	5	0.003236016	0	0.01618	0	0	0	0	0
RTS	ISP	10%	0.00032	0	402	0	53	0	3	0.003236016	0	0.00971	0	0	0	0	0
RTS	ISP	10%	0.00032	0	858	0	110	0	5	0.003236016	0	0.01618	0	0	0	0	0
RTS	ISP	10%	0.00032	0	1434	0	182	0	7	0.003236016	0	0.02265	0	0	0	0	0
RTS	ISP									<34>							
RTS	ISP	10%	0.00032	0	26	0	6	0	2	0.003236016	0	0.00647	0	0	0	0	0
RTS	PayInstr	10%	0.064000001	0	50	0	9	0	2	0.647203274	0	1.29441	0	0	0	0	0
RTS	PayInstr	10%	0.032	0	50	0	9	0	2	0.323601637	0	0.6472	0	0	0	0	0
RTS	PayInstr	10%	0.00032	0	50	0	9	0	2	0.003236016	0	0.00647	0	0	0	0	0
RTS	PayInstr	10%	0.00032	0	34	0	7	0	2	0.003236016	0	0.00647	0	0	0	0	0
TRMS	TRVS	100%	0.1	8210	0	1029	0	32	0	0.1	3.2	0	0	0	0	0	0
TRMS	TRVS									<2*34333+2>				0.2	2.4	0.8	
TRMS	TRVS	100%	0.32	26	0	6	0	2	0	32.36016371	64.7203	0	0	64.72033	0	0	0
TRMS	TRVS	10%	0.0032	2418	0	305	0	11	0	0.003236016	0.0356	0	0	0	0	0	0
TRMS	TRVS									<3332>				0.006472	0.029124		
TRMS	TRVS	100%	13	1042	0	133	0	6	0	13.01773533	78.1064	0	0	0	0	0	0
TRMS	TRVS									<411>			26.03547067			52.07094	
TRMS	TRVS	100%	0.032	82	0	13	0	2	0	0.032360164	0.06472	0	0	0.06472	0	0	0
TRMS	TRVS	100%	0.032	34	0	7	0	2	0	0.032360164	0.06472	0	0	0.06472	0	0	0
TRMS	TRVS	100%	13	17260	0	2160	0	65	0	13	845	0	0	0	0	0	0
TRMS	TRVS									<4*34333+5>				624.00	208.00		
TRMS	TRVS	100%	52	7786	0	976	0	30	0	52	1560	0	0	0	0	0	0
TRMS	TRVS									<34333+43333>					1248	416	
TRMS	TRVS	100%	1	16826	0	2106	0	63	0	0.541666667	34.125	0	0	0	0	0	0
TRMS	TRVS									<4*34333+5>				26.00	8.67		
TRMS	TRVS	100%	0.032	554	0	72	0	4	0	0.032360164	0.12944	0	0	0	0	0.129441	
TRMS	TRVS	100%	1	922	0	118	0	5	0	1	5	0	0	0	0	0	0
TRMS	TRVS	100%	32	26	0	6	0	2	0	32.36016371	64.7203	0	0	64.72033	0	0	0
TRMS	TRVS	100%	32	34	0	7	0	2	0	32.36016371	64.7203	0	0	64.72033	0	0	0
TRVS	PayInstr	100%	32	0	50	0	9	0	2	32.36016371	0	64.7203	0	0	0	0	0
TRVS	PayInstr	100%	32	0	34	0	7	0	2	32.36016371	0	64.7203	0	0	0	0	0
TRVS	TRMS	10%	0.0032	0	2418	0	305	0	11	0.003236016	0	0.0356	0	0	0	0	0
TRVS	TRMS									<3332>							
TRVS	TRMS	100%	13	0	26	0	6	0	2	52	0	104	0	0	0	0	0
TRVS	TRMS	100%	32	0	466	0	61	0	4	32.36016371	0	129.441	0	0	0	0	0
TRVS	TRMS	100%	0.1	0	34	0	7	0	2	0.1	0	0.2	0	0	0	0	0
TRVS	TRMS	100%	0.0032	0	282	0	38	0	3	0.003236016	0	0.00971	0	0	0	0	0
TRVS	TRMS	100%	0.0032	0	282	0	38	0	3	0.003236016	0	0.00971	0	0	0	0	0
TRVS	TRMS	100%	0.0032	0	1042	0	133	0	6	0.003236016	0	0.01942	0	0	0	0	0
TRVS	TRMS									<411>							
TRVS	TRMS	100%	3.2	0	186	0	26	0	3	3.236016371	0	9.70805	0	0	0	0	0
TRVS	TRMS	100%	0.011	0	73746	0	9221	0	271	0.013642565	0	3.69714	0	0	0	0	0
TRVS	TRMS									<18*34333+3>							
TRVS	TRMS	10%	0.0032	0	1450	0	184	0	7	0.003236016	0	0.02265	0	0	0	0	0
TRVS	TRMS									<34>							
TRVS	TRMS	100%	13	0	1042	0	133	0	6	13	0	78	0	0	0	0	0
TRVS	TRMS									<411>							
TRVS	TRMS	100%	13	0	1826	0	231	0	9	13	0	117	0	0	0	0	0
TRVS	TRMS									<4221>							
TRVS	TRMS	100%	52	0	274	0	37	0	3	52	0	156	0	0	0	0	0
TRVS	TRMS	100%	156	0	234	0	32	0	3	156	0	468	0	0	0	0	0
TRVS	TRMS	100%	32	0	26	0	6	0	2	32.36016371	0	64.7203	0	0	0	0	0

Table 8.1-18 Transit Vehicles CDPD Traffic for the Year 2002

Table 8.1-19 Personal Information Access CDPD Traffic for the Year 2002														Table 8.1-19 Personal Information Access C							
Personal Information Access			Peak Period: 6-9am & 4-7pm				21600		seconds												
Universe		876,390		Remote Access Users				87,639													
Mobile (Professional) Penetration			10%		Forward		Reverse		Forward		Reverse		Frequency*		Forward		Reverse		Forward Link		
PA Source	PA Sink	Penetration	Frequency	bits	bits	bytes	bytes	# blocks	# blocks	Penetration	blocks	blocks	blocks	blocks	blocks	blocks	blocks	blocks	blocks	blocks	
EM	PIAS	10%	0.000025	26	0	6	0	2	0	0.00005	0.0001	0	0	0	0.0001	0	0	0	0	0	
ISP	PIAS	10%	0.00025	3578	0	450	0	15	0	0.005	0.075	0	0	0	0	0	0	0	0	0	
ISP	PIAS										<532222>			0.04	0.015						
ISP	PIAS	7%	0.0035	18306	0	2291	0	69	0	0.07	4.83	0	0	0	0	0	0	0	0	0	
ISP	PIAS										<4x43333 + 45>			3.36	1.4						
ISP	PIAS	10%	0.005	818	0	105	0	5	0	0.01	0.05	0	0	0	0	0	0	0	0	0	
ISP	PIAS	10%	0.005	650	0	84	0	4	0	0.01	0.04	0	0	0	0	0	0	0	0	0.04	
ISP	PIAS	10%	0.05	1139.7	0	145	0	6	0	0.1	0.6	0	0	0	0	0	0	0	0	0	
ISP	PIAS										<51>			0.1							
LocData	PIAS	7%	0.007	146	0	21	0	2	0	0.007	0.014	0	0	0.014	0	0	0	0	0	0	
PayInstr	PIAS	10%	0.005	178	0	25	0	3	0	0.01	0.03	0	0	0	0	0	0	0	0.03	0	
PIAS	EM	10%	0.000025	0	370	0	49	0	3	0.00005	0	0.00015	0	0	0	0	0	0	0	0	
PIAS	ISP	10%	0.05	0	250	0	34	0	3	0.1	0	0.3	0	0	0	0	0	0	0	0	
PIAS	ISP	10%	0.0025	0	250	0	34	0	3	0.005	0	0.015	0	0	0	0	0	0	0	0	
PIAS	ISP	10%	0.05	0	210	0	29	0	3	0.1	0	0.3	0	0	0	0	0	0	0	0	
PIAS	ISP	10%	0.005	0	1130	0	144	0	6	0.01	0	0.06	0	0	0	0	0	0	0	0	
PIAS	ISP											<51>									
PIAS	ISP	10%	0.005	0	402	0	53	0	3	0.01	0	0.03	0	0	0	0	0	0	0	0	
PIAS	ISP	10%	0.05	0	26	0	6	0	2	0.1	0	0.2	0	0	0	0	0	0	0	0	
PIAS	PayInstr	10%	0.005	0	50	0	9	0	2	0.01	0	0.02	0	0	0	0	0	0	0	0	
PIAS	TRMS	10%	0.005	0	466	0	61	0	4	0.01	0	0.04	0	0	0	0	0	0	0	0	
TRMS	PIAS	10%	0.00165	2530	0	319	0	11	0	0.005	0.055	0	0	0	0	0	0	0	0	0	
TRMS	PIAS										<222222>			0.06							
														Total # blocks/User during peak period		0.1	0.1141	3.405	1.44		
														*Population		8763.9	9999.61	298410.8	126200.2		
														/peak period duration		0.405736111	0.462945	13.81531	5.8426		
														/per sector		0.00176407	0.002013	0.060067	0.025403		
														packets/s		7.454	1.441	0.40574	0.23147	4.60510	1.46065
																5.4%	3.1%	61.8%	19.6%		

Table 8.1-19 Personal Information Access CDPD Traffic for the Year 2002

Table 8.1-20 Probe Vehicles CDPD Traffic for the Year 2002											Table 8.1-20 Probe Vehicles CDPD Traffic fo						
<b>Traffic Management = Probes</b>																	
Number of users:		7,704															
Peak Period: 6-9am & 4-7pm		21600 seconds															
PA Source	PA Sink	Penetration	Frequency	Forward bits	Reverse bits	Forward bytes	Reverse bytes	Forward # blocks	Reverse # blocks	Frequency* Penetration	Forward blocks	Reverse blocks	Forward Link	1	2	3	4
VS	ISP	100%	12	0	314	0	42	0	3	12	0	36					
Total # blocks/User during peak period											0						
*Population											0						
/peak period duration											0						
/per sector											0						
packets/s											0.000 4.280 0.00000 0.00000 0.00000 0.00000						

**Table 8.1-20 Probe Vehicles CDPD Traffic for the Year 2002, Urbansville**

**Table 8.1-21 ITS CDPD Traffic Summary for the Year 2002**

**(a) ITS CDPD Traffic**

	Forward	1	2	3	4	5
Traveller Information	24.27965	0.405736	0.462945	13.81531	5.8426	3.753059
Transit	92.26808	0.815556	8.160471	59.53479	21.47918	2.27808
Probe Vehicles	0	0	0	0	0	0
Private Vehicles	117.2653	0	39.69736	57.61183	19.95614	0
Emergency Vehicles	8.082918	2.694306	0	0	5.388612	0
CVO Local	228.1739	18.65936	66.45758	55.29576	35.82596	51.93521
CVO Long	10.61325	0.518315	3.042452	4.249579	1.318298	1.484604
RS-Blocks/s		23.09327	117.8208	190.5073	89.8108	59.45095
Packets/s		23.09327	58.9104	63.50243	22.4527	11.89019
Packets/s per Sector		0.100406	0.256132	0.276098	0.09762	0.051696

**Total Forward Link CDPD Traffic: 0.295 Erlang**

	Reverse	1	2	3	4	5
Traveller Information	3.915962	0.040574	0.892619	2.617607	0.162294	0.202868
Transit	63.49485	1.221869	11.48263	42.91129	7.877541	0.001521
Probe Vehicles	12.84	0	0	12.84	0	0
Private Vehicles	15.86513	0	2.72478	11.55921	1.58114	0
Emergency Vehicles	16.16584	0	10.77722	0	5.388612	0
CVO Local	113.2944	19.69599	74.84724	1.249555	17.50165	0
CVO Long	7.943628	0.814496	3.170787	1.428729	2.529616	0
RS-Blocks/s		21.77293	103.8953	72.60639	35.04085	0.204389
Packets/s		21.77293	51.94764	24.20213	8.760213	0.040878
Packets/s per Sector		0.094665	0.225859	0.105227	0.038088	0.000178

**Total Reverse Link CDPD Traffic: 0.265 Erlang**

**(b) CDPD Traffic Packet Distribution**

Distribution	1	2	3	4	5
Forward	12.840%	32.755%	35.309%	12.484%	6.611%
Reverse	20.401%	48.675%	22.677%	8.208%	0.038%

It is clear from Table 8.1-21 that most of the traffic is generated by and directed to CVO Local, and Private Vehicles, although Transit Vehicles receive a lot of traffic.

The forward channel operates obviously far below capacity. This fact allows for reducing, as a first-cut, the delay in the forward link to queuing delay. As for the reverse channel, due to the inherent contention mechanism, only simulation can provide the necessary delay/throughput information.

**8.1.5.1.2.2 Non-ITS Data Load**

Trying to conservatively estimate the Non-ITS data loads, we projected that the non-ITS data load would be **2.5** times that of ITS in the reverse direction (from the user to the F-ES's), and that it would be 4 times higher than that (i.e., **10** times the ITS traffic in the reverse direction) in the forward direction. The

reason for this different treatment is that, as we have already discussed, the reverse direction traffic is mostly due to E-mail, while the forward traffic consists mainly of E-mail and WWW Access, with its associated downloads, and is therefore expected to be much larger.

The resulting traffic for Urbansville 2002 is, therefore, as shown in Table 8.1-22.

**Table 8.1-22 Non-ITS CDPD Traffic**

Non-ITS Traffic	Forward	1	2	3	4	5
RS-Blocks/s per Sector		3.3724	2.248267	2.248267	1.26465	0.8431
Packets/s per Sector		3.3724	1.124133	0.749422	0.316163	0.16862
	Reverse	1	2	3	4	5
RS-Blocks/s per Sector		0.8431	0.562067	0.562067	0.316163	0.210775
Packets/s per Sector		0.8431	0.281033	0.187356	0.079041	0.042155

The distribution, as was discussed before, is taken to be the same in both directions. The resulting overall traffic follows in Table 8.1-23.

**Table 8.1-23 Overall ITS plus Non-ITS CDPD Traffic**

Total Traffic	Forward	1	2	3	4	5
RS-Blocks/s per Sector		3.472806	2.760531	3.076559	1.655132	1.101582
Packets/s per Sector		3.472806	1.380266	1.02552	0.413783	0.220316
Distribution		53.324%	21.193%	15.746%	6.353%	3.383%
	Reverse	1	2	3	4	5
RS-Blocks/s per Sector		0.937765	1.013785	0.877747	0.468514	0.211664
Packets/s per Sector		0.937765	0.506893	0.292582	0.117129	0.042333
Distribution		49.442%	26.725%	15.426%	6.175%	2.232%

**8.1.5.1.2.3 Incident Case**

The incident case for Urbansville was defined by MITRE. Unfortunately, at the time when the information was requested, all the simulation files obtained from Integration had already been erased. Given time constraints, it was not possible to re-run Integration for the Urbansville scenario, and the information provided to the Joint Team (February 1, 1996) was the following:

1. Incident occurring at the intersection of Ford and Lodge freeways in downtown Detroit, in the direction E-W, affecting approximately 2.5 miles of freeway. This information was used to conclude that two sectors would be affected by the incident, namely Tiger Stadium #1, and Baltimore #3. Furthermore, most of the congestion occurs within the Tiger Stadium #1 sector.
  - a) Number of vehicles in the most affected sector under normal peak period traffic conditions: 4905.
  - b) Number of vehicles in the most affected sector immediately before the incident began to clear: 7256.



In order to analyze a worst case scenario, we assumed that all the vehicles identified as being in the most affected sector were in the affected link of freeway. Furthermore, we assumed that all those vehicles, independent of their direction, would be affected. (In reality, assuming equilibrium during the peak period, only approximately 4800 [ $\sim 7256 - (4905/2)$ ] vehicles are affected by the incident). As such, we have maximized the CDPD traffic increase due to the incident, i.e., its impact on CDPD performance (see Figure 8.1-9).

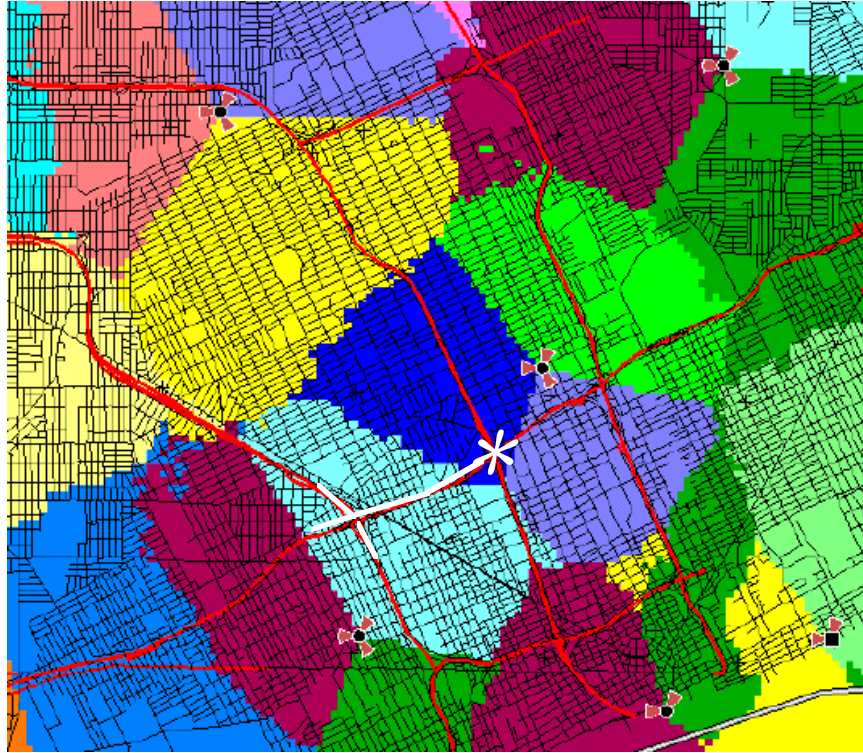


Figure 8.1-9 Location of the Incident showing the Sectors Involved, as well as the Sectors and Roadway Segments Affected by the Incident

### **8.1.5.2 Thruville 2002**

It should be noted that the Data Loading analysis in this document, as well as the *Evaluatory Design* document, looked at only the New Jersey side of Thruville. Given that our cellular deployment extended into the Pennsylvania side, where Philadelphia is located, we had to extend the population figures considered therein to account for the whole scenario.

In any case, as it is very easy to observe, the ITS traffic considered for Thruville is quite different from that analyzed for Urbansville. This stems, as explained in the *Evaluatory Design* document, from the different set of ITS services scheduled for deployment in this inter-urban scenario.

#### **8.1.5.2.1 ITS only**

Table 8.1-24 through Table 8.1-31 summarize the data load for the 2002 time frame for Thruville (Philadelphia-Trenton corridor). As shown in Table 8.1-31, the data loads are now significantly smaller than those in Detroit, given that a smaller set of ITS services will be deployed at that time.

Table 8.1-24 Private Vehicles CDPD Traffic for the Year 2002

Private Vehicle

1.086276259 Factor due to through traffic

Number of users: 3,202,686

Peak Period: 6-9am/4-7pm

21600 s

Penetration

7%

100%

(DL Freq) \*

PA Source	PA Sink	Physical Data Flow	Penetration	Penetration	1/(DL Freq)	Explanation	Number
EM	VS	emergency_request_driver_acknowledge	10%	0.0001	1000	one emergency per 1000 vehicles	1000
EM	VS	emergency_request_vehicle_acknowledge	10%	0.0001	1000	one emergency per 1000 vehicles	1000
LocData	VS	From_Location_Data_Source	7%	0.007	10	one in 10 vs	10
PayInstr	VS	fpi_transit_user_vehicle_input_credit_identity	100%	0.0001	10000	one in 10000 vehicles this flow	10000
VS	EM	emergency_request_driver_details	10%	0.0001	1000	one emergency per 1000 vehicles	1000
VS	EM	emergency_request_vehicle_details	10%	0.0001	1000	one emergency per 1000 vehicles	1000
VS	ISP	advisory_data_request	10%	0.1	1	one request per vehicle	1
VS	ISP	vehicle_guidance_route_accepted	7%	0.14	1/2	two acceptances	1/2

W.C. Factor	Forward		Reverse		Forward		Reverse		Frequency Penetration	Forward		Forward Link					Reverse Link		
	bits	bits	bytes	bytes	# blocks	# blocks	blocks	blocks		1	2	3	4	5	1	2	3		
1	26	0	6	0	2	0	0.0001	0.0002	0	0.0002	0	0	0	0	0	0	0	0	
1	26	0	6	0	2	0	0.0001	0.0002	0	0.0002	0	0	0	0	0	0	0	0	
1	146	0	21	0	2	0	0.007	0.014	0	0.014	0	0	0	0	0	0	0	0	
1	178	0	25	0	3	0	0.0001	0.0003	0	0	0.0003	0	0	0	0	0	0	0	
1	0	282	0	38	0	3	0.0001	0	0.0003	0	0	0	0	0	0	0	0	0.0003	
1	0	3354	0	422	0	14	0.0001	0	0.0014	0	0	0	0	0	0	0	0	0	
					<53322>													0.0004	0.0006
1	0	290	0	39	0	3	0.1	0	0.3	0	0	0	0	0	0	0	0	0	0.3
1	0	34	0	7	0	2	0.14	0	0.28	0	0	0	0	0	0	0	0	0.28	0
Total # blocks/User											0	0.0144	0.0003	0	0	0	0	0.2804	0.3009
*Population											0	50097.63	1043.701	0	0	0	0	975512.1	1046832
/peak period duration											0	2.319335	0.048319	0	0	0	0	45.1626	48.46443
/per sector											0	0.010084	0.00021	0	0	0	0	0.196359	0.210715

Table 8.1-25 Long-Haul Freight and Fleet Vehicles CDPD Traffic for the Year 2002											Table 8.1-25 Long-Haul Freight and Fleet Vehicles CDPD Traffic for the Year 2002																					
CVO Long Haul											CVO Long Haul																					
Number of users: 24,717											1.0862763 Factor due to through traffic																					
Peak Period: 43200											Penetration: 7%																					
6am-6pm (12 hours)											100% (DL Freq)																					
50% of LH Trucks operating in a Metro Area																																
PA Source	PA Sink	Physical Data Flow	Penetration	Penetration	1/DL Freq	Explanation	Number	W.C. Factor	Forward bits	Reverse bits	Forward bytes	Reverse bytes	Forward # blocks	Reverse # blocks	Frequency Penetration	Forward blocks	Reverse blocks	Forward Link	Reverse Link	1	2	3	4	5	1	2	3	4	5			
CVAS	CVCS	cv_credentials_database_update	50%	0.0005	10000	1 out of 1000 vehicles	1000	10	482	0	63	0	4	0	0.0005	0.002	0															
CVAS	CVCS	cv_credentials_information_response	50%	0.005	100	1 out of 10 vehicles	10	10	410	0	54	0	3	0	0.05	0.15	0															
CVAS	CVCS	cv_safety_database_update	100%	0.001	1000	1 out of 100 vehicles	100	10	410	0	54	0	3	0	0.01	0.03	0															
CVAS	CVCS	cv_safety_information_response	100%	0.001	1000	1 out of 100 vehicles are transmitted	100	10	410	0	54	0	3	0	0.01	0.03	0															
CVAS	FMS	cf_clearance_enrollment_confirm	50%	0.05	10	1 per vehicle	1	10	26	0	6	0	2	0	0.5	1	0															
CVAS	FMS	cf_enrollment_information	50%	0.025	20	1 out of 2 vehicles require info.	2	10	3818	0	480	0	16	0	0.25	4	0															
CVAS	FMS	cf_enrollment_payment_confirmation	50%	0.05	10	1 per vehicle	1	10	170	0	24	0	3	0	0.5	1.5	0															
CVAS	FMS	cv_enrollment_information	50%	0.025	20	1 out of 2 vehicles require info.	2	10	3818	0	480	0	16	0	0.25	4	0															
CVAS	FMS	cv_enrollment_payment_confirmation	50%	0.05	10	1 per vehicle	1	10	346	0	46	0	3	0	0.5	1.5	0															
CVCS	CVAS	cv_credentials_information_request	50%	0.005	100	request info on 1 in 10 vehicles	10	10	0	554	0	72	0	4	0.05	0	0.2															
CVCS	CVAS	cv_roadside_daily_log	50%	0.0005	1000	1 report per 100 vehicles	100	10	0	3362	0	423	0	14	0.005	0	0.07															
CVCS	CVAS	cv_safety_information_request	100%	0.01	100	request info on 1 in 10 vehicles	10	10	0	554	0	72	0	4	0.1	0	0.4															
CVCS	CVAS	cv_update_safety_problems_list	100%	0.001	1000	1 out of 100 vehicles are on the list	100	10	0	538	0	70	0	4	0.01	0	0.04															
CVS	FMS	cf_driver_route_instructions_request	50%	0.5	1	average fleet vehicle requests 1 route	1	1	0	154	0	22	0	2	0.5	0	1															
CVS	FMS	cv_driver_enrollment_payment_request	50%	0.5	1	1 per vehicle	1	1	0	330	0	44	0	3	0.5	0	1.5															
CVS	FMS	cv_driver_enrollment_request	50%	0.5	1	1 per vehicle	1	1	0	39	0	15	0	2	0.5	0	1															
CVS	FMS	cv_driver_route_request	50%	1	1/2	average vehicle requests 2 routes	1/2	1	0	1234	0	157	0	6	1	0	6															
CVS	FMS	cv_driver_storage_request	50%	0.05	10	1 in 10 vehicles	10	1	0	26	0	6	0	2	0.05	0	0.1															
CVS	FMS	cv_static_route_data	50%	1	1/2	2 routes per vehicle	1/2	1	0	2066	0	261	0	1	0	9																
EM	FMS	cf_hazmat_request	10%	0.0001	10000	1 per 1000 vehicles	1000	10	146	0	21	0	2	0	0.0001	0.0002	0															
EM	VS	emergency_request_driver_acknowledge	10%	0.0001	1000	1 emergency per 1000 vehicles	1000	1	26	0	6	0	2	0	0.0001	0.0002	0															
EM	VS	emergency_request_vehicle_acknowledge	10%	0.0001	1000	1 emergency per 1000 vehicles	1000	1	26	0	6	0	2	0	0.0001	0.0002	0															
FMS	CVAS	cf_enroll_clearance_data	50%	0.05	10	1 per vehicle	1	10	0	402	0	53	0	3	0.5	0	1.5															
FMS	CVAS	cf_enrollment_payment_request	50%	0.05	10	1 per vehicle	1	10	0	414	0	54	0	3	0.5	0	1.5															
FMS	CVAS	cf_enrollment_request	50%	0.05	10	1 per vehicle	1	10	0	3498	0	440	0	15	0.5	0	7.5															
FMS	CVAS	cv_enrollment_payment_request	50%	0.05	10	1 per vehicle	1	10	0	414	0	54	0	3	0.5	0	1.5															
FMS	CVAS	cv_enrollment_request	50%	0.05	10	1 per vehicle	1	10	0	3498	0	440	0	15	0.5	0	7.5															
FMS	CVS	cf_driver_route_instructions	50%	0.5	1	1 per vehicle	1	1	5082	0	638	0	20	0	0.5	10	0															
FMS	CVS	cv_driver_enrollment_information	50%	0.25	2	1 out of 2 vehicles require info.	2	1	82	0	13	0	2	0	0.25	0.5	0															
FMS	CVS	cv_driver_enrollment_payment_confirmation	50%	0.5	1	1 per vehicle	1	1	346	0	46	0	3	0	0.5	1.5	0															
FMS	CVS	cv_driver_route_data	50%	1	1/2	average vehicle requests 2 routes	1/2	1	3042	0	383	0	13	0	1	13	0															
FMS	CVS	cv_static_route_request	50%	1	1/2	average vehicle requests 2 routes	1/2	1	1226	0	156	0	6	0	1	6	0															
FMS	EM	cf_hazmat_route_information	10%	0.0001	10000	1 per 1000 vehicles	1000	10	0	3754	0	472	0	16	0.0001	0	0.0016															
FMS	EM	cf_hazmat_vehicle_information	10%	0.0001	10000	1 per 1000 vehicles	1000	10	0	242	0	33	0	3	0.0001	0	0.0003															
FMS	ImFrighT	To_Intermodal_Freight_Depot	50%	0.005	100	1 in 10 vehicles interacts 1 with an intermodal carrier	10	10	0	530	0	69	0	4	0.05	0	0.2															
FMS	ImFrighT	To_Intermodal_Freight_Shipper	50%	0.005	100	1 in 10 vehicles interacts 1 with an intermodal carrier	10	10	0	530	0	69	0	4	0.05	0	0.2															
FMS	ISP	cf_route_request	50%	0.05	10	1 per vehicle	1	10	0	1234	0	157	0	6	0.5	0	3															
FMS	ISP	cv_route_request	50%	0.1	5	twice per vehicle	1/2	10	0	1354	0	172	0	7	1	0	7															
FMS	PayInstr	tpi_debited_commercial_manager_payment	50%	0.05	10	1 per enrollment	1	10	0	50	0	9	0	2	0.5	0	1															
ImFrighT	FMS	From_Intermodal_Freight_Depot	50%	0.005	100	1 in 10 vehicles interacts 1 with an intermodal carrier	10	10	530	0	69	0	4	0	0.05	0.2	0															
ImFrighT	FMS	From_Intermodal_Freight_Shipper	50%	0.005	100	1 in 10 vehicles interacts 1 with an intermodal carrier	10	10	530	0	69	0	4	0	0.05	0.2	0															
ISP	FMS	cf_route	50%	0.05	10	1 per vehicle	1	10	3034	0	382	0	13	0	0.5	6.5	0															
ISP	FMS	cv_route	50%	0.1	5	twice per vehicle	1/2	10	3154	0	397	0	13	0	1	13	0															
LocData	VS	From_Location_Data_Source	7%	0.007	10	1 in 10 vehicles 1	10	1	146	0	21	0	2	0	0.007	0.014	0															
PayInstr	FMS	tpi_commercial_manager_input_credit_identity	50%	0.05	10	1 per enrollment = 1 per cv	1	10	114	0	17	0	2	0	0.5	1	0															
VS	EM	emergency_request_driver_details	10%	0.0001	1000	1 emergency per 1000 vehicles	1000	1	0	282	0	38	0	3	0.0001	0	0.0003															
VS	EM	emergency_request_vehicle_details	10%	0.0001	1000	1 emergency per 1000 vehicles	1000	1	0	3354	0	422	0	14	0.0001	0	0.0014															
VS	ISP	advisory_data_request	10%	0.2	1/2	2 requests per vehicle	1/2	1	0	290	0	39	0	3	0.2	0	0.6															
VS	ISP	vehicle_guidance_route_accepted	7%	0.14	1/2	2 acceptances	1/2	1	0	34	0	7	0	2	0.14	0	0.28															
																Total # blocks/User																
																4 15.5146 12.21 16.402 20 6.5 9.4106 9.6468 23.0408 5.0005																
																/Population 53698.98 208279.6 163916.1 220192.7 268494.9 87260.84 126334.9 129505.8 309316.9 67130.44																
																/peak period duration 1.243032 4.821286 3.794355 5.097053 6.21516 2.019827 2.924419 2.99782 7.160113 1.553945																
																/per sector 0.003733 0.014478 0.011394 0.015306 0.018664 0.006066 0.008782 0.009002 0.021502 0.004667																

Table 8.1-26 Local Freight and Fleet Vehicles CDPD Traffic for the Year 2002											Table 8.1-26 Local Freight and Fleet Vehicles CDPD Traffic for the Year 2002																					
CVO Local																																
Number of users: 346,039											Penetration																					
Peak Period: 6am-6pm											7%																					
43200 s											50% (DL Freq)																					
FA Source	FA Sink	Physical Data Flow	Penetration	Penetration	1/(DL Freq)	1/(DL Freq)	Explanation	Number	W.C. Factor	Forward bits	Reverse bits	Forward bytes	Reverse bytes	Forward # blocks	Reverse # blocks	Frequency Penetration	Forward blocks	Reverse blocks	Forward Link	Reverse Link	1	2	3	4	5	1	2	3	4	5		
CVS	FMS	cf_driver_route_instructions_request	50%	1	1/2	1/2	average fleet vehicle requests 2 routes	1/2	1	0	154	0	22	0	2	11	0	2	0	0	0	0	0	0	0	2	0	0	0	0		
CVS	FMS	cv_driver_route_request	50%	2	1/4	1/4	average vehicle requests 4 routes	1/4	1	0	1234	0	157	0	6	2	0	12	0	0	0	0	0	0	0	0	0	0	0	0		
CVS	FMS	cv_driver_storage_request	50%	0.05	10	10	1 in 10 vehicles	10	1	0	26	0	6	0	2	0.05	0	0.1	0	0	0	0	0	0	0	0.1	0	0	0	0		
CVS	FMS	cv_static_route_data	50%	2	1/4	1/4	4 routes per vehicle	1/4	1	0	2066	0	261	0	9	2	0	18	0	0	0	0	0	0	0	0	0	0	0	0		
EM	FMS	cf_hazmat_request	10%	0.0001	10000	10000	1 per 1000 vehicles	10000	10	146	0	21	0	2	0	0.0001	0.0002	0	0	0.0002	0	0	0	0	0	0	0	0	0	0	0	
EM	VS	emergency_request_driver_acknowledge	10%	0.0001	1000	1000	1 emergency per 1000 vehicles	1000	1	26	0	6	0	2	0	0.0001	0.0002	0	0	0.0002	0	0	0	0	0	0	0	0	0	0	0	
EM	VS	emergency_request_vehicle_acknowledge	10%	0.0001	1000	1000	1 emergency per 1000 vehicles	1000	1	26	0	6	0	2	0	0.0001	0.0002	0	0	0.0002	0	0	0	0	0	0	0	0	0	0	0	
FMS	CVS	cf_driver_route_instructions	50%	1	1/2	1/2	twice per vehicle	1/2	1	5082	0	638	0	20	0	1	20	0	0	0	0	0	0	0	0	0	0	0	0	0	0	
FMS	CVS	cv_driver_route_data	50%	2	1/4	1/4	average vehicle requests 4 routes	1/4	1	3042	0	383	0	13	0	2	26	0	0	0	0	0	0	0	0	0	0	0	0	0	0	
FMS	CVS	cv_static_route_request	50%	2	1/4	1/4	average vehicle requests 4 routes	1/4	1	1226	0	156	0	6	0	2	12	0	0	0	0	0	0	0	0	0	0	0	0	0	0	
FMS	EM	cf_hazmat_route_information	10%	0.0001	10000	10000	1 per 1000 vehicles	10000	10	0	3754	0	472	0	16	0.0001	0	0.0016	0	0	0	0	0	0	0	0	0	0	0	0	0	
FMS	EM	cf_hazmat_vehicle_information	10%	0.0001	10000	10000	1 per 1000 vehicles	10000	10	0	242	0	33	0	3	0.0001	0	0.0003	0	0	0	0	0	0	0	0	0.0003	0.0008	0.0005	0	0	
FMS	ImFrighD	To_Intermodal_Freight_Depot	50%	0.005	100	100	1 in 10 of vehicles interact 1 with an intermodal carrier	100	10	0	530	0	69	0	4	0.05	0	0.2	0	0	0	0	0	0	0	0	0	0	0.2	0		
FMS	ImFrighS	To_Intermodal_Freight_Shipper	50%	0.005	100	100	1 in 10 of vehicles interact 1 with an intermodal carrier	100	10	0	530	0	69	0	4	0.05	0	0.2	0	0	0	0	0	0	0	0	0	0	0.2	0		
FMS	ISP	cf_route_request	50%	0.1	5	1/2	twice per vehicle	1/2	10	0	1234	0	157	0	6	1	0	6	0	0	0	0	0	0	0	0	0	0	0	0	0	
FMS	ISP	cv_route_request	50%	0.2	2	1/2	4 times per vehicle	1/4	10	0	1354	0	172	0	7	2	0	14	0	0	0	0	0	0	0	3	4	0	0	0		
ImFrighD	FMS	From_Intermodal_Freight_Depot	50%	0.005	100	100	1 in 10 of vehicles interact 1 with an intermodal carrier	100	10	530	0	69	0	4	0	0.05	0.2	0	0	0	0	0.2	0	0	0	0	0	0	0	0	0	
ImFrighS	FMS	From_Intermodal_Freight_Shipper	50%	0.005	100	100	1 in 10 of vehicles interact 1 with an intermodal carrier	100	10	530	0	69	0	4	0	0.05	0.2	0	0	0	0	0.2	0	0	0	0	0	0	0	0	0	
ISP	FMS	cf_route	50%	0.1	5	1/2	twice per vehicle	1/2	10	3034	0	382	0	13	0	1	13	0	0	0	0	0	0	0	0	0	0	0	0	0	0	
ISP	FMS	cv_route	50%	0.2	2	1/2	4 times per vehicle	1/4	10	3154	0	397	0	13	0	2	26	0	0	0	0	0	0	0	0	0	0	0	0	0	0	
LocData	VS	From_Location_Data_Source	7%	0.007	10	10	1 in 10 vehicles 1	10	1	146	0	21	0	2	0	0.007	0.014	0	0.014	0	0	0	0	0	0	0	0	0	0	0	0	
VS	EM	emergency_request_driver_details	10%	0.0001	1000	1000	1 emergency per 1000 vehicles	1000	1	0	282	0	38	0	3	0.0001	0	0.0003	0	0	0	0	0	0	0	0	0.0003	0	0	0	0	
VS	EM	emergency_request_vehicle_details	10%	0.0001	1000	1000	1 emergency per 1000 vehicles	1000	1	0	3354	0	422	0	14	0.0001	0	0.0014	0	0	0	0	0	0	0	0	0	0	0	0	0	
VS	ISP	advisory_data_request	10%	0.2	1/2	1/2	2 requests per vehicle	1/2	1	0	290	0	39	0	3	0.2	0	0.6	0	0	0	0	0	0	0	0	0	0.6	0	0	0	
																	Total # blocks/User	8	16.0146	36	8.4	35	13	26.1006	0.6018	8.4008	10.0005					
																	Population	2768312	5541676	12457404	2906728	12111965	4498507	9031626	2082463	2907004	3460563					
																	/peak period duration	64.0813	128.2795	288.3658	67.28536	280.3557	104.1321	209.071	4.820516	67.29177	80.10563					
																	/per sector	0.192436	0.385224	0.865963	0.202058	0.841909	0.312709	0.627838	0.014476	0.202077	0.240557					

Table 8.1-27 Emergency Vehicles CDPD Traffic for the Year 2002											Table 8.1-27 Emergency Vehicles CDPD Traffic for the Year 2002																
Emergency Vehicle																											
Number of users:																											
Peak Period 6am-7pm											(13 hours)																
46800 s											Penetration 100%																
46800 s											(DL Freq)																
PA Source	PA Sink	Physical Data Flow	Penetration	(DL Freq)	1/(DL Freq)	Explanation	Number	W.C. Factor	Forward bits	Reverse bits	Forward bytes	Reverse bytes	Forward # blocks	Reverse # blocks	Frequency Penetrator	Forward blocks	Reverse blocks	Forward Link					Reverse Link				
1	2	3	4	5	6	7	8	9	10	11	12	13	14	15	16	17	18	19	20	21	22	23	24	25			
EM	EVS	emergency_vehicle_driver_outputs	100%	13	1/13	average one driver output per vehicle per hour	1/13	1	1042	0	133	0	6	0	13	78	0	0	0	0	0	0	0	0			
EVS	EM	emergency_driver_dispatch_acknowledge	100%	26	1/26	average one dispatch acknowledge per vehicle per 1/2 hour	1/26	1	0	26	0	6	0	2	26	0	52	13	0	0	0	0	0	0			
EVS	EM	emergency_driver_status_update	100%	26	1/26	average one status update per vehicle per 1/2 hour	1/26	1	0	146	0	21	0	2	26	0	52	0	0	0	0	0	0	0			
EVS	EM	emergency_vehicle_driver_inputs	100%	13	1/13	average one driver input per vehicle per hour	1/13	1	0	530	0	69	0	4	13	0	52	0	0	0	0	0	0	0			
																Total # blocks/User	13	0	0	0	65	0	104	0	52	0	
																*Population	243581	0	0	0	1217905	0	1948648	0	974324	0	
																/peak period duration	5.204722	0	0	0	26.02361	0	41.63778	0	20.81889	0	
																/per sector	0.01563	0	0	0	0.078149	0	0.125038	0	0.062519	0	









**Table 8.1-31 ITS CDPD Traffic Summary for Thruville 2002**

**(a) ITS CDPD Traffic**

	Forward	1	2	3	4	5
<b>Traveller Information</b>	21.5125	0.5680	1.4692	3.4690	10.2246	5.7817
<b>Transit Vehicles</b>	124.9990	1.0694	18.2838	39.0223	44.1652	22.4583
<b>Probe Vehicles</b>	0.0000	0.0000	0.0000	0.0000	0.0000	0.0000
<b>Private Vehicles</b>	2.3677	0.0000	2.3193	0.0483	0.0000	0.0000
<b>Emergency Vehicles</b>	31.2283	5.2047	0.0000	0.0000	0.0000	26.0236
<b>CVO Local</b>	828.3677	64.0813	128.2795	288.3658	67.2854	280.3557
<b>CVO Long</b>	21.1709	1.2430	4.8213	3.7944	5.0971	6.2152
RS-Blocks/s		72.1665	155.1731	334.6998	126.7721	340.8345
Packets/s		72.1665	77.5866	111.5666	31.6930	68.1669
Packets/s per Sector		0.2167	0.2330	0.3350	0.0952	0.2047

**Total Forward Link CDPD Traffic: 0.0744 Erlang**

	Reverse	1	2	3	4	5
<b>Traveller Information</b>	1.2178	0.0000	0.0000	1.2178	0.0000	0.0000
<b>Transit Vehicles</b>	71.1298	1.6042	6.4648	53.3598	9.6625	0.0385
<b>Probe Vehicles</b>	53.8884	0.0000	0.0000	53.8884	0.0000	0.0000
<b>Private Vehicles</b>	93.7076	0.0000	45.1626	48.4644	0.0000	0.0805
<b>Emergency Vehicles</b>	62.4567	0.0000	41.6378	0.0000	20.8189	0.0000
<b>CVO Local</b>	465.4201	104.1321	209.0700	4.8205	67.2918	80.1056
<b>CVO Long</b>	16.6562	2.0199	2.9244	2.9978	7.1601	1.5539
RS-Blocks/s		107.7562	305.2597	164.7487	104.9332	81.7786
Packets/s		107.7562	152.6298	54.9162	26.2333	16.3557
Packets/s per Sector		0.3236	0.4583	0.1649	0.0788	0.0491

**Total Reverse Link CDPD Traffic: 0.0569 Erlang**

**(b) CDPD Traffic Packet Distribution**

Distribution	1	2	3	4	5
Forward	19.981%	21.481%	30.890%	8.775%	18.873%
Reverse	30.109%	42.647%	15.344%	7.330%	4.570%

**8.1.5.2.2 Non-ITS Data Load**

The non-ITS data load requires in this scenario a more detailed analysis. The Thruville scenario encompasses, as the Government has repeated stressed, an urban scenario including the city of Philadelphia, PA, and an inter-urban corridor in the New Jersey side.

The approach adopted here was to maintain the same assumptions as for Urbansville for the urban portion of the scenario, corresponding to Pensilvania, but to take a more conservative approach for the New Jersey portion. So, the factors 2.5 times and 10 times reverse link ITS loads were used for the urban (PA) portion for the reverse link and forward link non-ITS loads, respectively. Those factors were reduced to 2.5 times and 5 times reverse link ITS loads for the interurban (NJ) portion. We decided to keep the same factor for the reverse link as a worst case situation, although we think it should be smaller in the NJ side.

The resulting traffic for Thruville 2002 is, therefore, as shown in Table 8.1-32.

**Table 8.1-32 Non-ITS CDPD Traffic for Thruville 2002**

<b>Forward</b>	<b>1</b>	<b>2</b>	<b>3</b>	<b>4</b>	<b>5</b>
RS-Blocks/s	2318.482	1545.654	1545.654	869.431	579.620
Packets/s	2318.482	772.827	515.218	217.358	115.924
Packets/s per Sector	6.962407	2.320802	1.547202	0.652726	0.34812
<b>Reverse</b>	<b>1</b>	<b>2</b>	<b>3</b>	<b>4</b>	<b>5</b>
RS-Blocks/s	646.036	430.691	430.691	242.264	161.509
Packets/s	646.036	215.345	143.564	60.566	32.302
Packets/s per Sector	1.940049	0.646683	0.431122	0.18188	0.097002

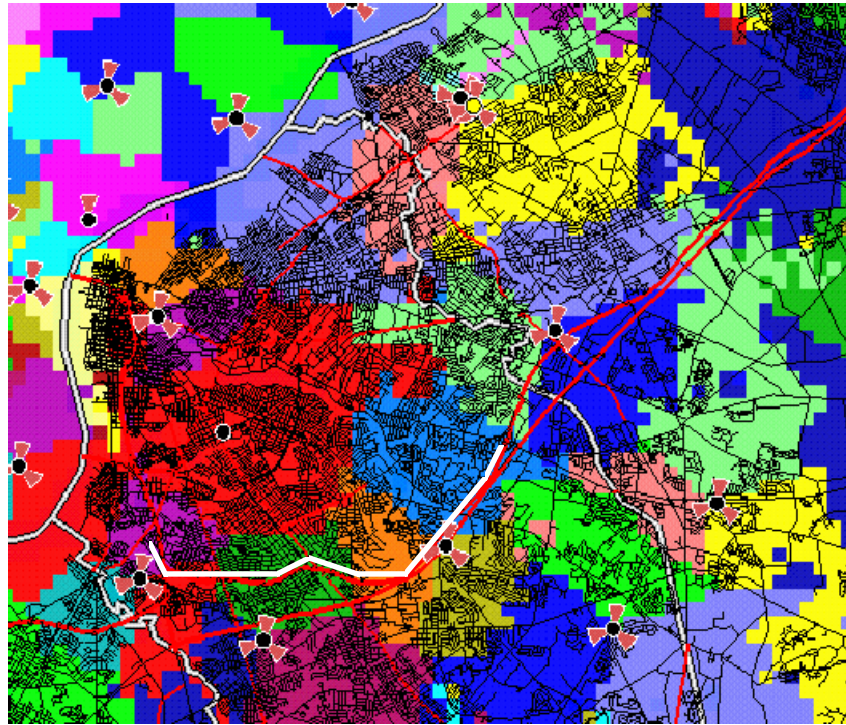
The distribution, as it was discussed before, is taken to be the same in both directions. The resulting overall traffic follows in Table 8.1-33.

**Table 8.1-33 Overall ITS plus Non-ITS CDPD Traffic for Thruville 2002**

<b>Forward</b>	<b>1</b>	<b>2</b>	<b>3</b>	<b>4</b>	<b>5</b>
RS-Blocks/s	2390.648	1700.828	1880.354	996.203	920.455
Packets/s	2390.648	850.414	626.785	249.051	184.091
Packets/s per Sector	7.179123	2.553795	1.882236	0.7479	0.552826
Distribution	55.584%	19.773%	14.573%	5.791%	4.280%
<b>Reverse</b>	<b>1</b>	<b>2</b>	<b>3</b>	<b>4</b>	<b>5</b>
RS-Blocks/s	753.793	735.951	595.440	347.197	243.288
Packets/s	753.793	367.975	198.480	86.799	48.658
Packets/s per Sector	2.263642	1.105031	0.596036	0.260658	0.146119
Distribution	51.782%	25.278%	13.635%	5.963%	3.343%

### 8.1.5.2.3 Incident Case

MITRE provided extensive information on an incident occurring at the intersection of an interstate highway and a state highway. All the sectors affected by the resulting increase in traffic were identified (see Figure 8.1-10).



**Figure 8.1-10 Extension of the Queues induced by the Incident immediately before its Dissipation, showing the Affected Sectors**

It must be understood that the above queues built up during a long interval. As a result, when the last vehicles were added to the queue, 20 minutes had already passed. The implication is that all the vehicles stuck had all that time to try to arrange for a solution (although, obviously, none was available).

## **8.2 CDPD Simulation Results**

### **8.2.1 Urbansville 2002 and 2012**

The actual cellular deployment in Detroit (as of November 1993) used in Phase I, was used again in Phase II to analyze the three time frames (and their loads). We begin by showing in Figure 8.2-1 the coverage for Detroit as provided by GRANET.

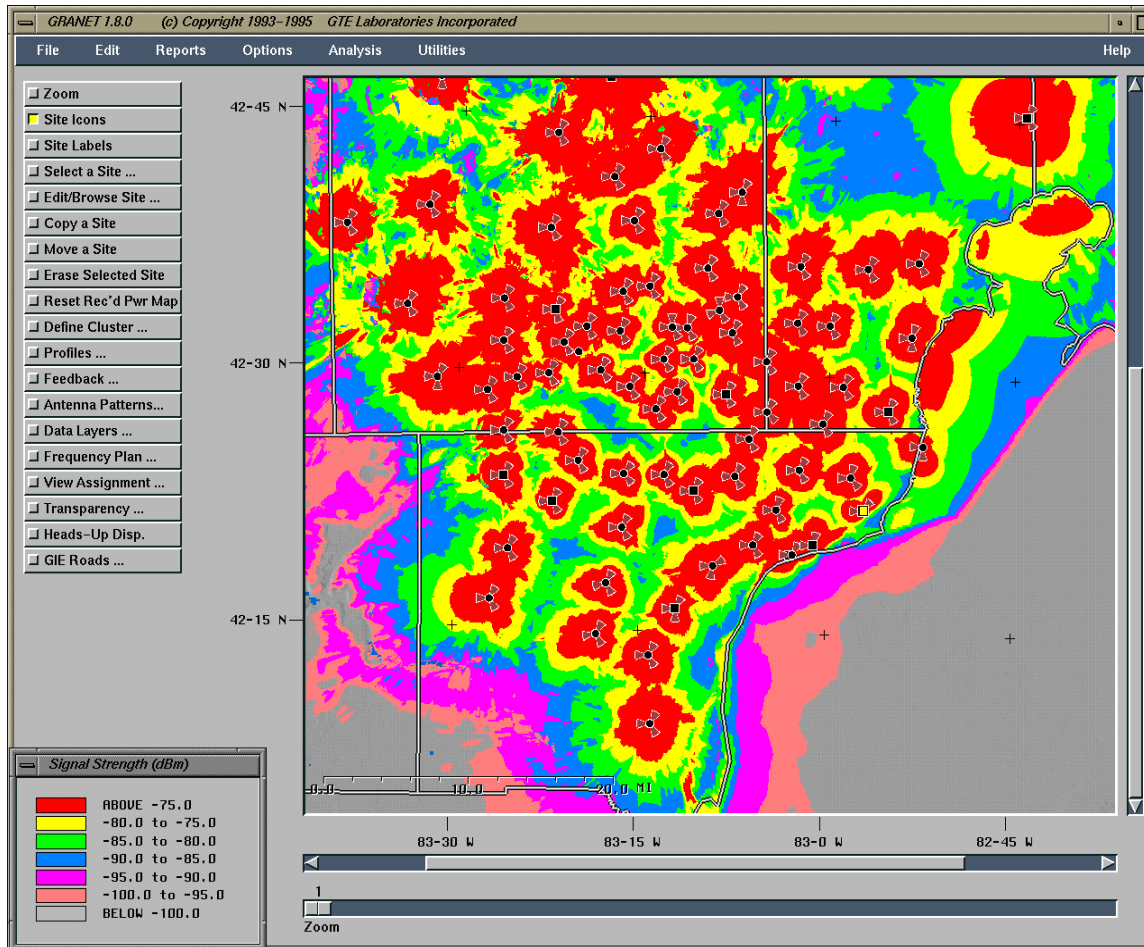
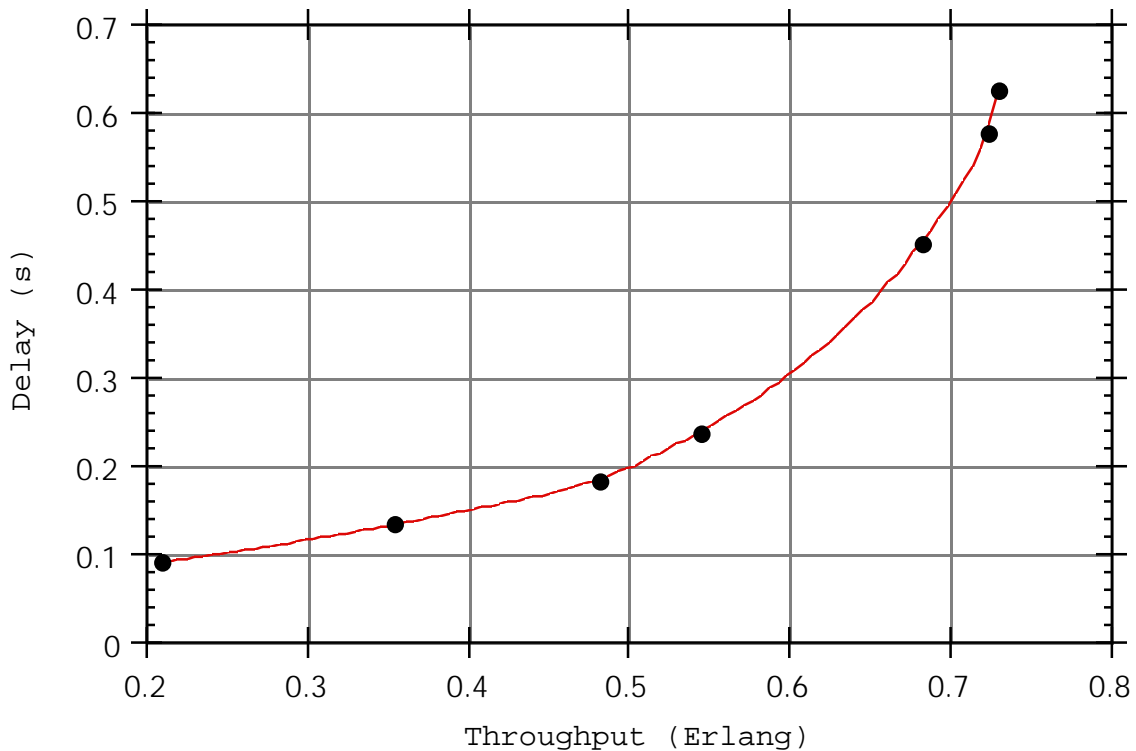


Figure 8.2-1 Detroit (Urbansville) Coverage

### 8.2.1.1 Capacity Comparison of One Reserved CDPD Channel versus One Reserved Plus One Dynamically Assigned CDPD Channels

We see in Figure 8.2-2 that the CDPD channel capacity, assuming the channel is reserved, is slightly higher than 0.7 Erlang for an idealized deployment with 11.5 Erlang voice activity and 19 voice channels per sector (see Phase I Document). That capacity corresponds to an effective throughput higher than  $0.7 \times 19.2 \times 47/63 \text{ kbps} \cong 10 \text{ kbps}$  including the TCP/IP overhead (i.e., the net effective throughput is smaller).



**Figure 8.2-2 Capacity of a Reserved CDPD Channel**

It is now interesting to compute the capacity for the case where a second CDPD channel is dynamically assigned when voice does not require all voice channels.

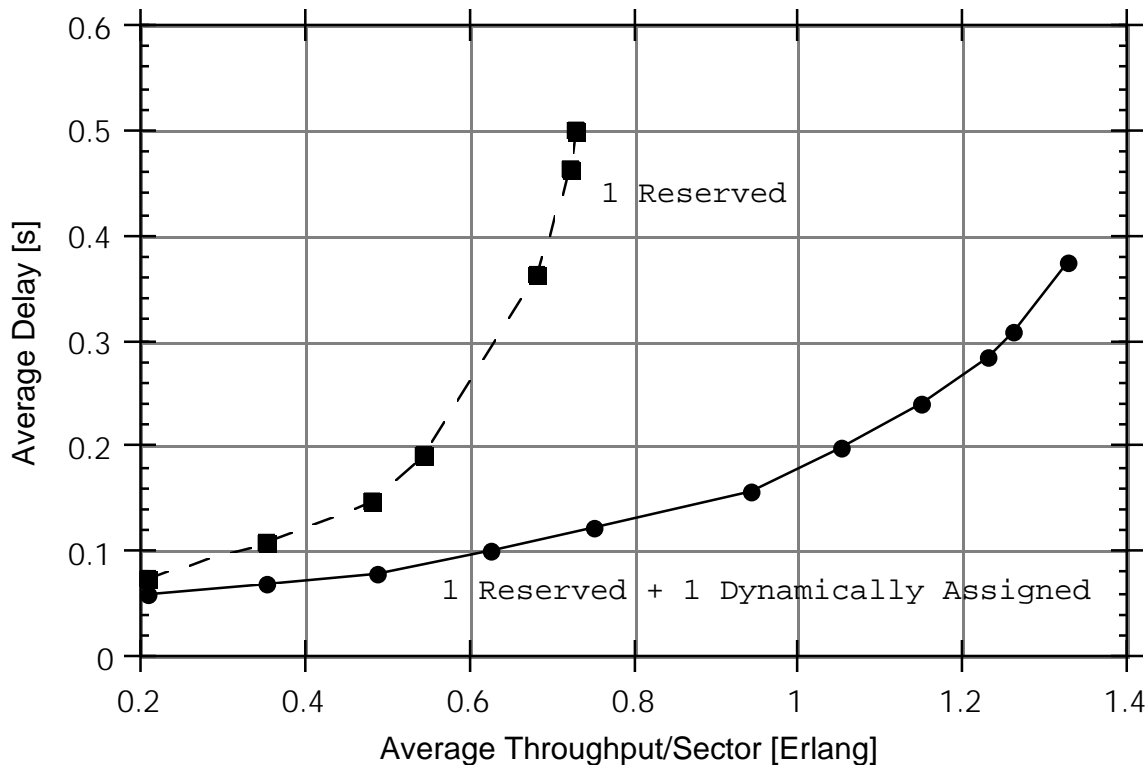
The following assumptions were made for the use of a dynamically assigned channel:

1. If a second channel is available and assigned to CDPD, the traffic is evenly split between the two channels.
2. When the dynamically assigned channel is called away for voice usage, all users on that channel will crowd onto the fixed CDPD channel:
  - a. Any swapped “call” in transmission (TX) mode will enter the BACK-OFF state;
  - b. All swapped “calls” waiting for a TRANSMIT-DONE flag stop waiting and enter the BACK-OFF state;
  - c. All swapped “calls” in BACK-OFF remain in BACK-OFF.



3. Once a voice channel frees up again and is assigned to CDPD:
  - a. The “calls” in IDLE mode, as well as those in WAITING-TO-TX mode, will be evenly split between the two channels;
  - b. All “calls” already in TX or waiting for a TRANSMIT-DONE flag will remain on the fixed channel;
  - c. All “calls” in BACK-OFF remain on the fixed channel.

Figure 8.2-3 shows that the capacity of the new “channel” is higher than 1.3 Erlang, not much less than twice that of the single, reserved CDPD channel. The dynamic use of only one additional channel is responsible for the small difference referring to twice the capacity of one reserved CDPD channel.



**Figure 8.2-3 Capacity of One Reserved plus One Dynamically Assigned CDPD Channels**

### 8.2.1.2 Urbansville 2012 -- One Reserved CDPD Channel

Figure 8.2-4 shows the delay/throughput pairs corresponding to all sectors in the Detroit MSA. Although the general behavior closely matches the delay/throughput curves obtained in the previous section, we observe quite a few sectors with inferior performance. The reason for this phenomenon is the fact that the present day cellular infrastructure has been designed for voice, which is more tolerant of noise and interference than data. Consequently, for a few sectors the available C/I, although appropriate for voice, was low for data.

Figure 8.2-5 is a color-coded map of the Detroit area showing the average delay in each sector. We easily identify in this map the sectors which would require some sort of re-engineering in order to improve CDPD performance. Note, however, that the average delay, for the worst sectors, does not exceed 0.5 s.

Although network re-engineering will happen quite frequently over a ten or twenty year period to accommodate network usage and other changes (in practice this is done every few weeks), we will not try to re-engineer any sector to make it perform better.

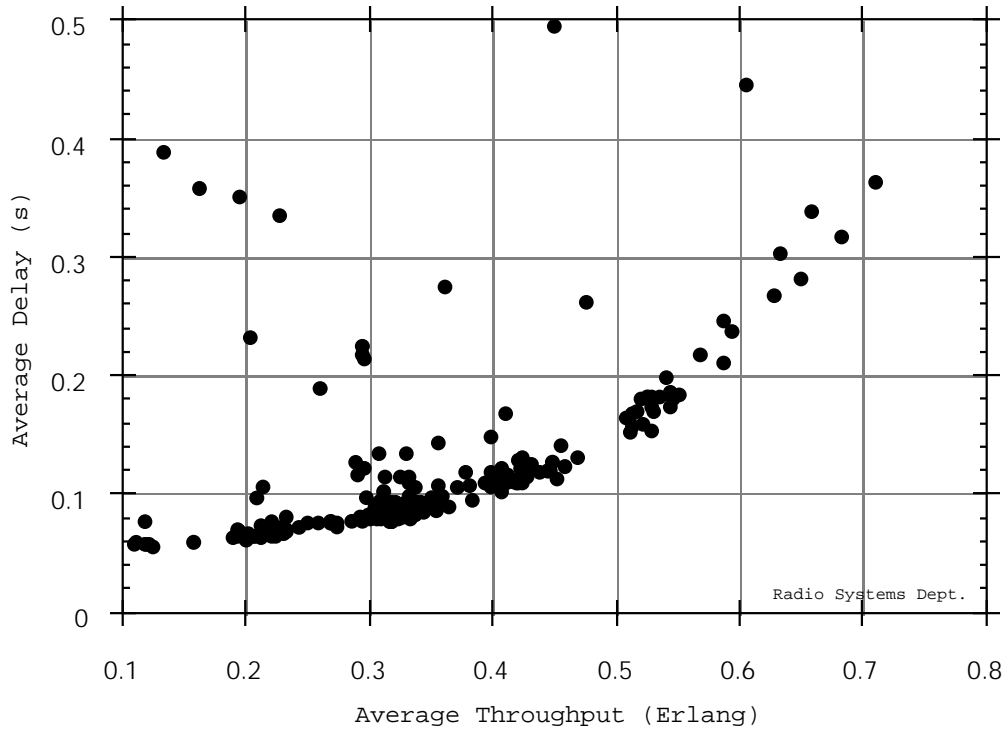


Figure 8.2-4 Delay/Throughput Pairs for the Actual Cellular Deployment in Detroit

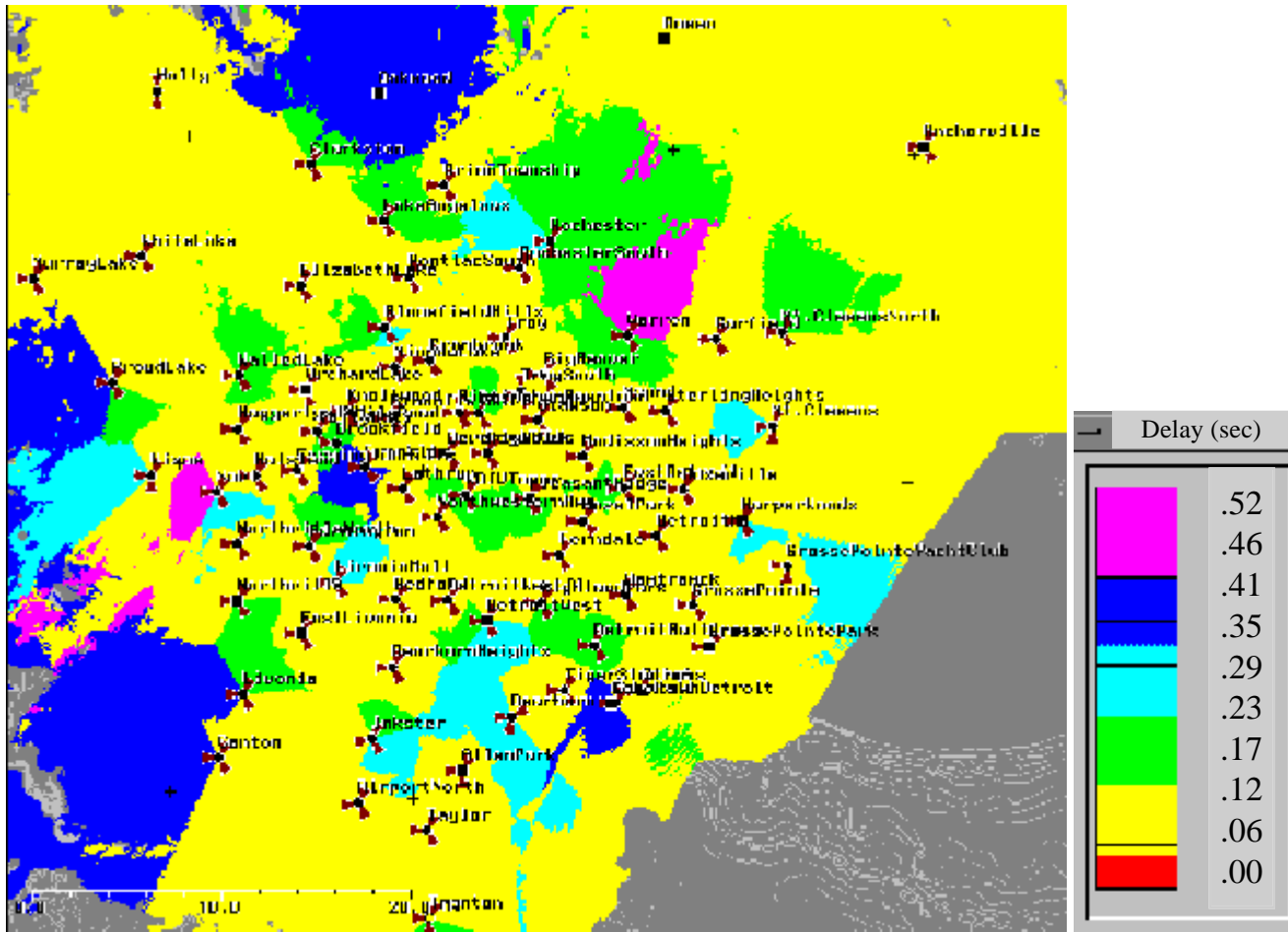


Figure 8.2-5: Delay Map for Urbansville 2012 (Phase 1 Data Loads) for an Actual Cellular Deployment in Detroit

### 8.2.1.3 Urbansville 2002 -- One Reserved CDPD Channel

#### 8.2.1.3.1 Peak-Period ITS only

A new, detailed characterization of the CDPD Reverse Link delay is shown in Figure 8.2-6. The delay histograms are presented in logarithmic form to emphasize the all important tail. A few observations can be made. First, one concludes that there is an underlying continuous probability density function for the delay accompanied with discrete peaks at 29, 50, 71, 93, 124 ms, for 1, 2, 3, 4, and 5 RS-blocks long packets, respectively. Those specific delays correspond to the unimpeded transmission of 1, 2, 3, 4, and 5 RS-blocks long packets, respectively, which happens quite often (61 to 88% of the mass of probability concentrated there) since the CDPD channel is lightly loaded and coverage is in general good. All the remaining points correspond to the occurrence of extra delays due to contention and/or channel impairments.

Referring to the tail of the distribution, we represented the probability of occurrence of delays bigger than one second in the “outlier” at the extreme right. Note that the probability of getting such delays is very small (0.2 to 0.9% of the cases).

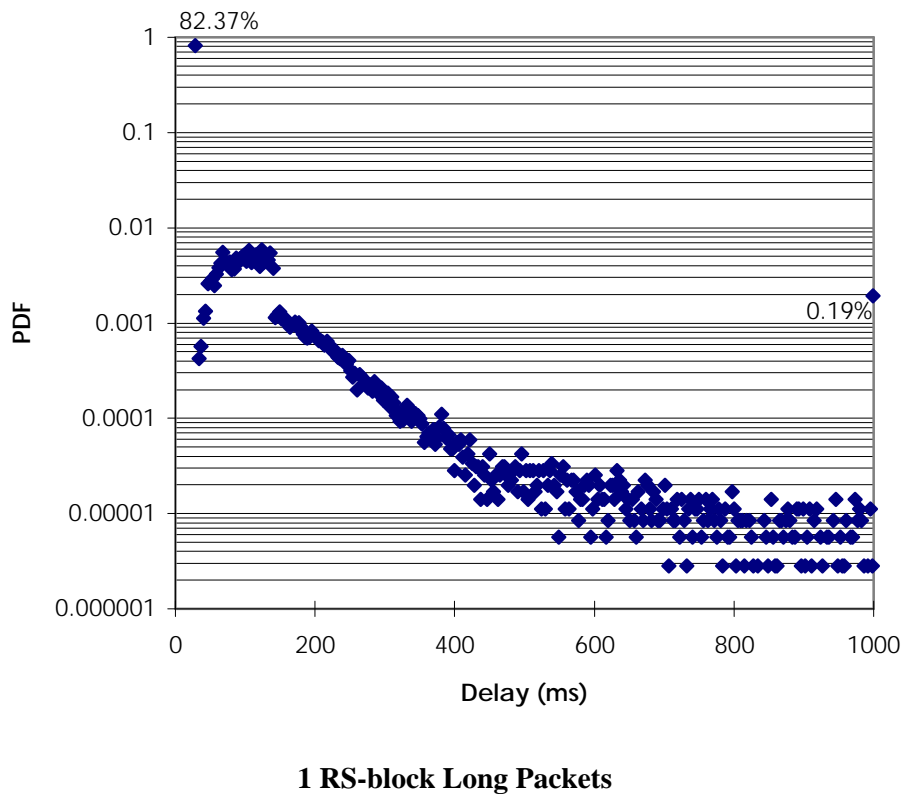
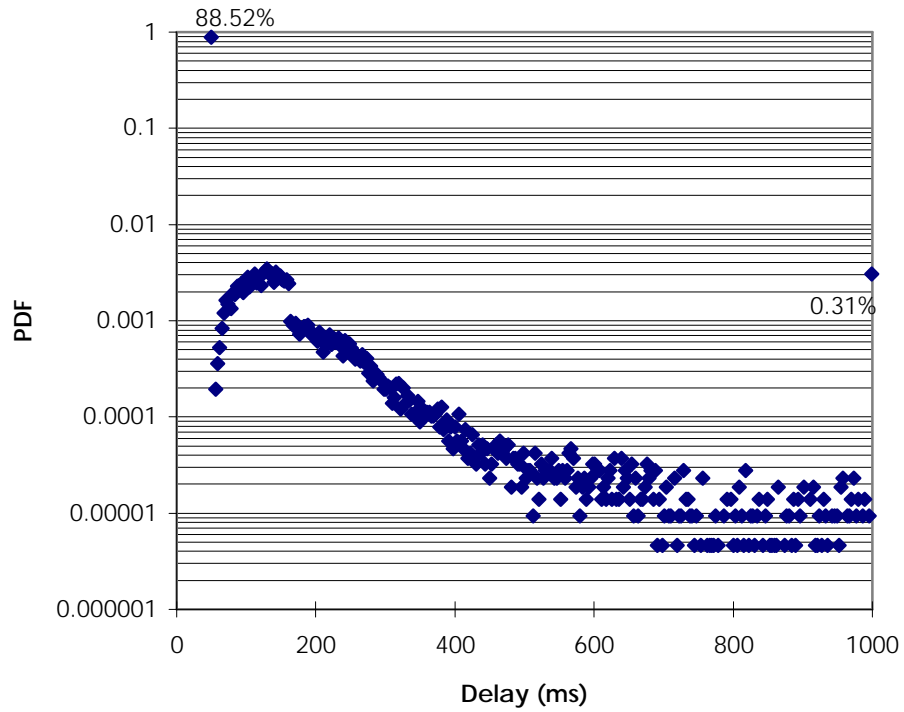
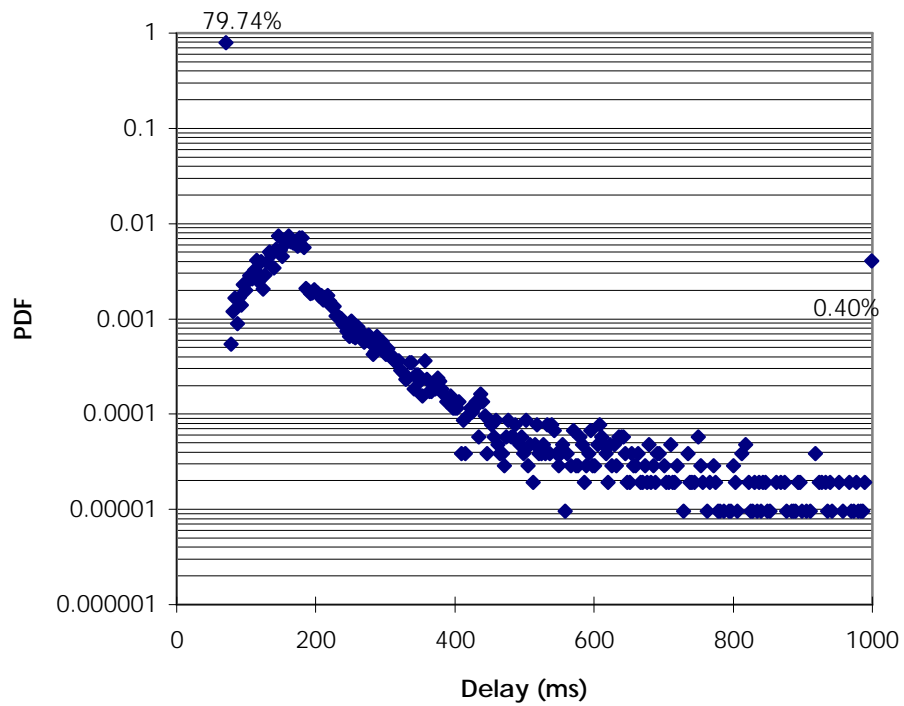


Figure 8.2-6 Reverse Link CDPD Delay Histograms on a Logarithmic Scale

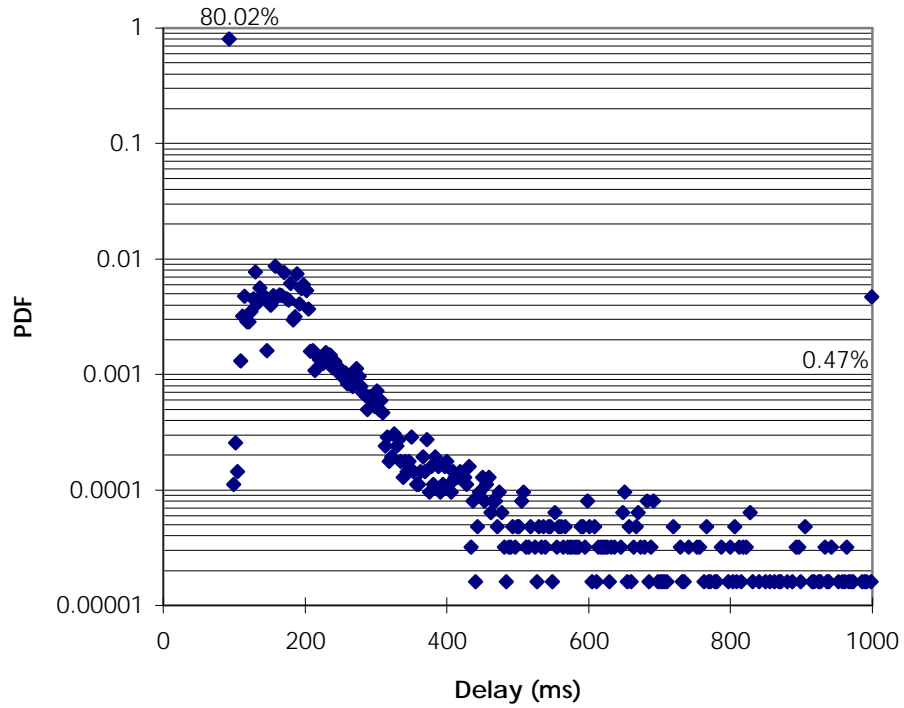


**2 RS-blocks Long Packets**

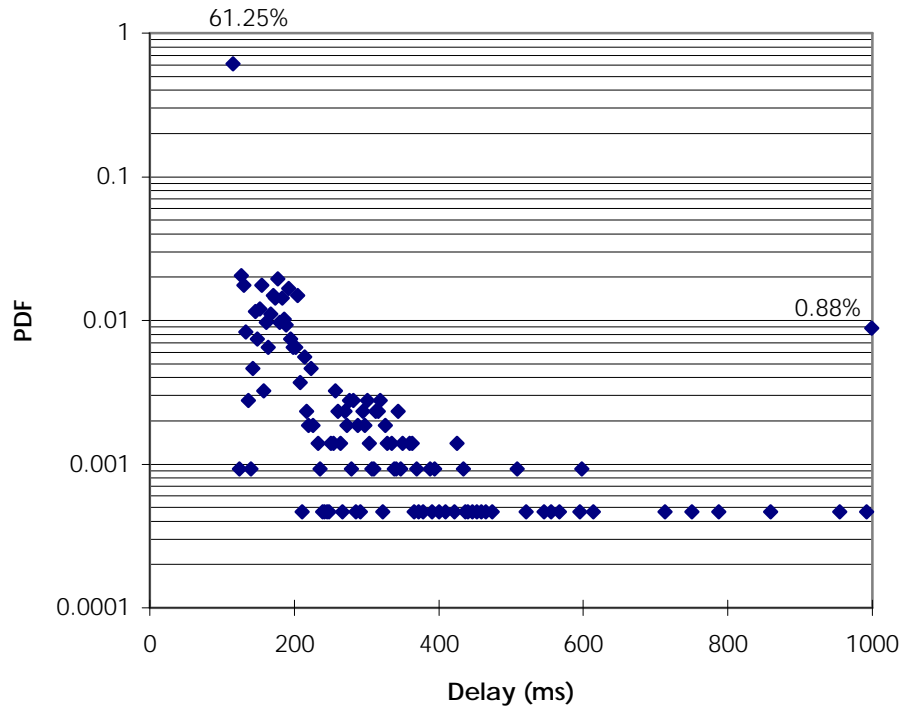


**3 RS-blocks Long Packets**

**Figure 8.2-6 ( Cont.) Reverse Link CDPD Delay Histograms on a Logarithmic Scale**



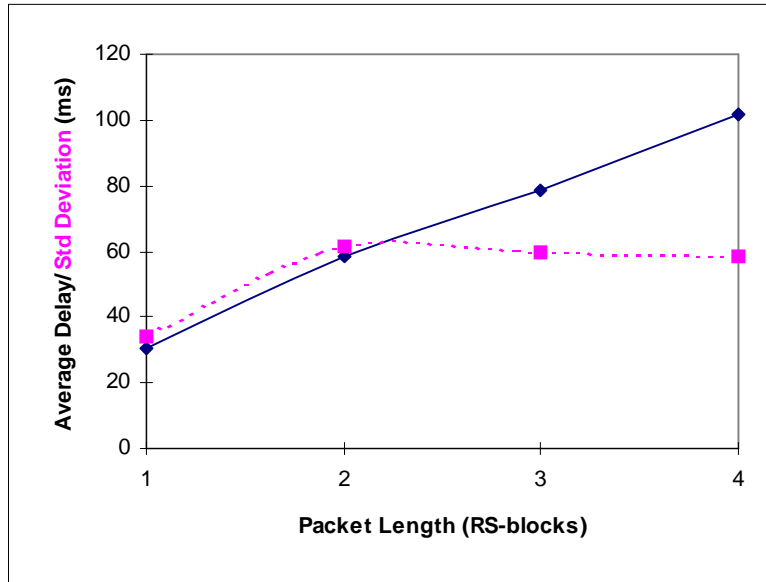
**4 RS-blocks Long Packets**



**5 RS-blocks Long Packets**

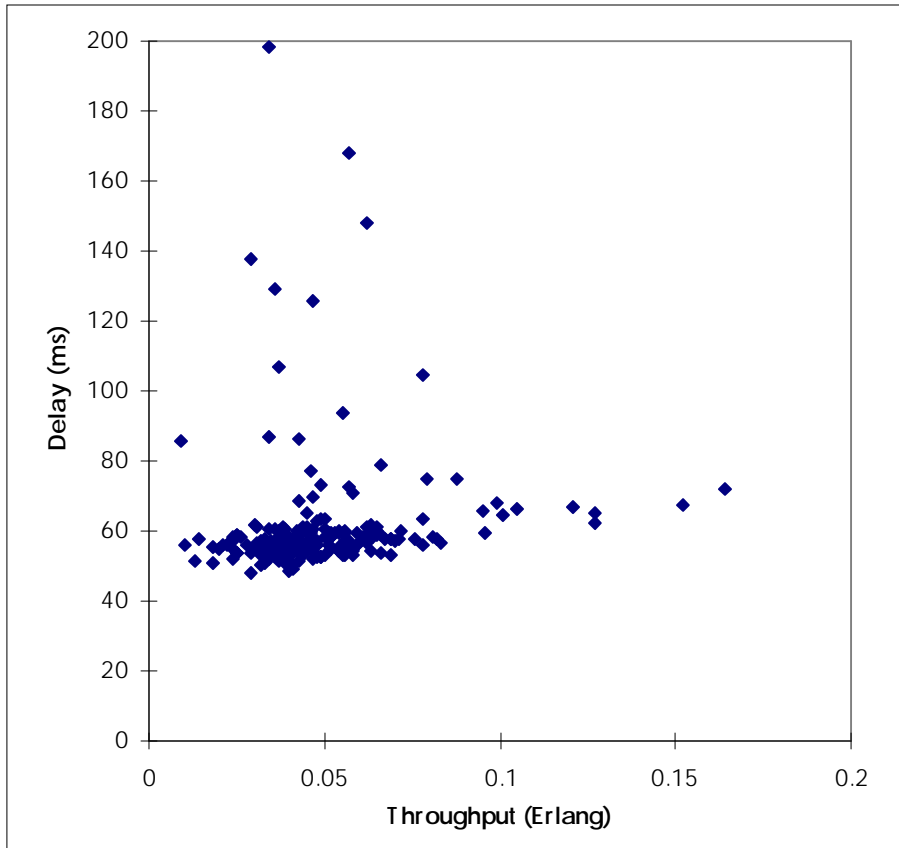
**Figure 8.2-6 (Con't.) Reverse Link CDPD Delay Histograms on a Logarithmic Scale**

The distributions arrived at in the previous figures result in the Average and Standard Deviations in Figure 8.2-7. We observe that, as expected, the longer the packet, the longer the delay – in fact, we observe an almost linear relation. The explanation is obvious, in that it takes longer to transmit longer packets over a fixed rate channel like the Reverse CDPD channel. The observed standard deviation, or better still, the standard deviation normalized by the average delay, decreases with increasing packet length.



**Figure 8.2-7 Average Delay and Standard Deviation as a function of Packet Length**

As in Phase I, we obtained the average delay for all sectors in the Detroit area. Since no step has yet been taken to correct the radio engineering issues detected in Phase I, we still observe in Figure 8.2-8 a few “ill-behaved” sectors with somewhat higher delays.



**Figure 8.2-8 Delay-Throughput Pairs for all the Sectors in Detroit 2002**

In any case, only two out of 230 sectors have average delays above 150 ms. All these results are obviously better than those in Phase I since the traffic is now significantly smaller (because of lower penetrations in 2002 than in 2012). Figure 8.2-9 presents a color-coded delay map of Detroit for the case of ITS loads only.



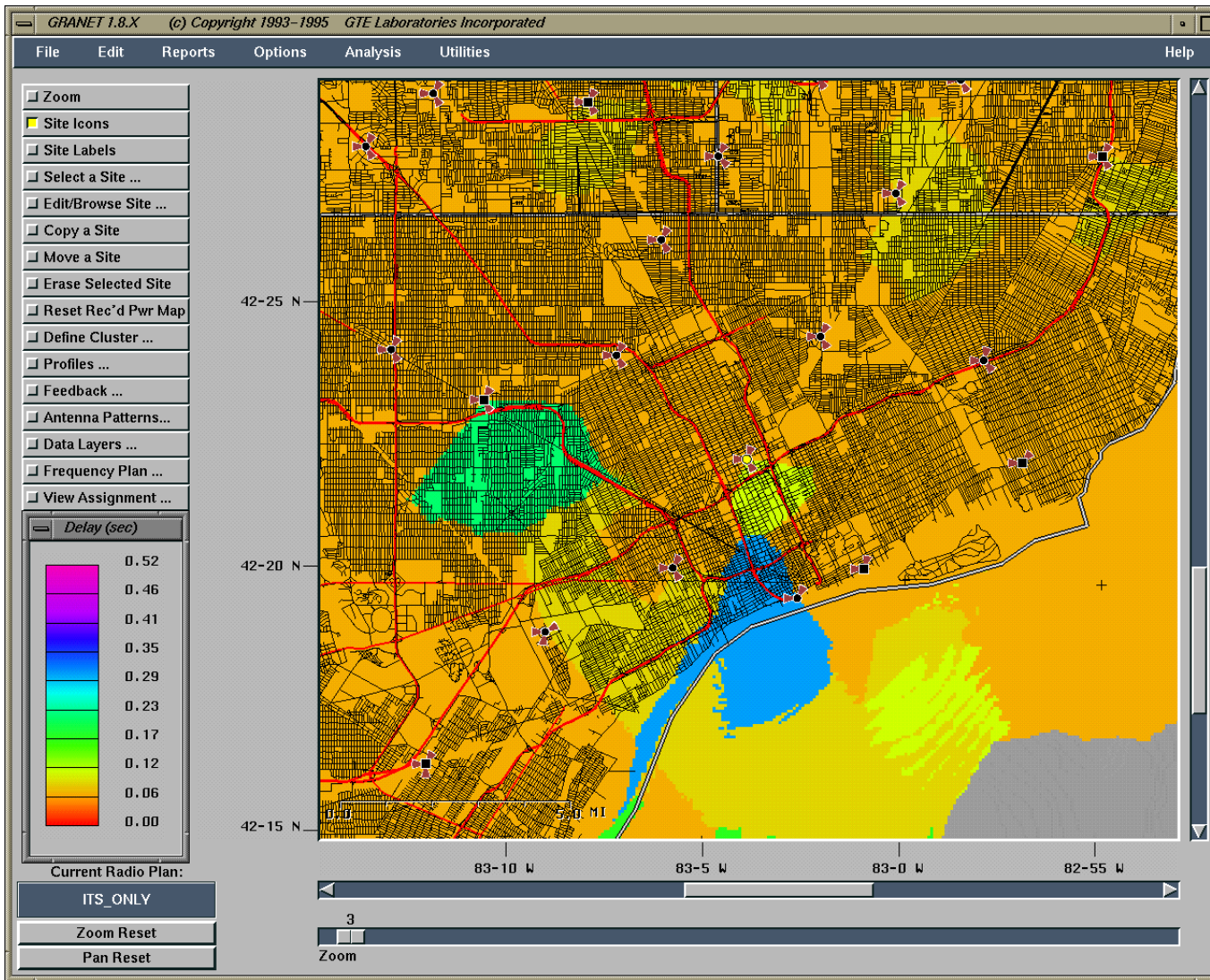
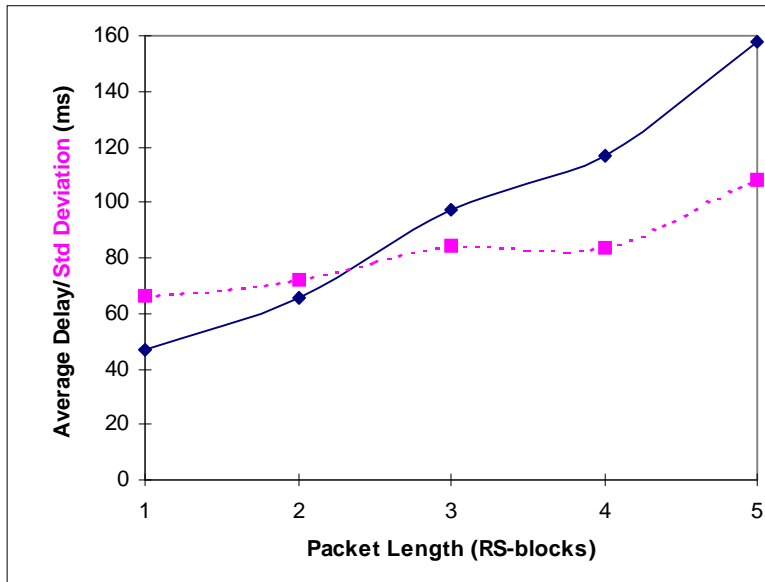


Figure 8.2-9 ITS only CDPD Reverse Link Delay for Urbansville 2002

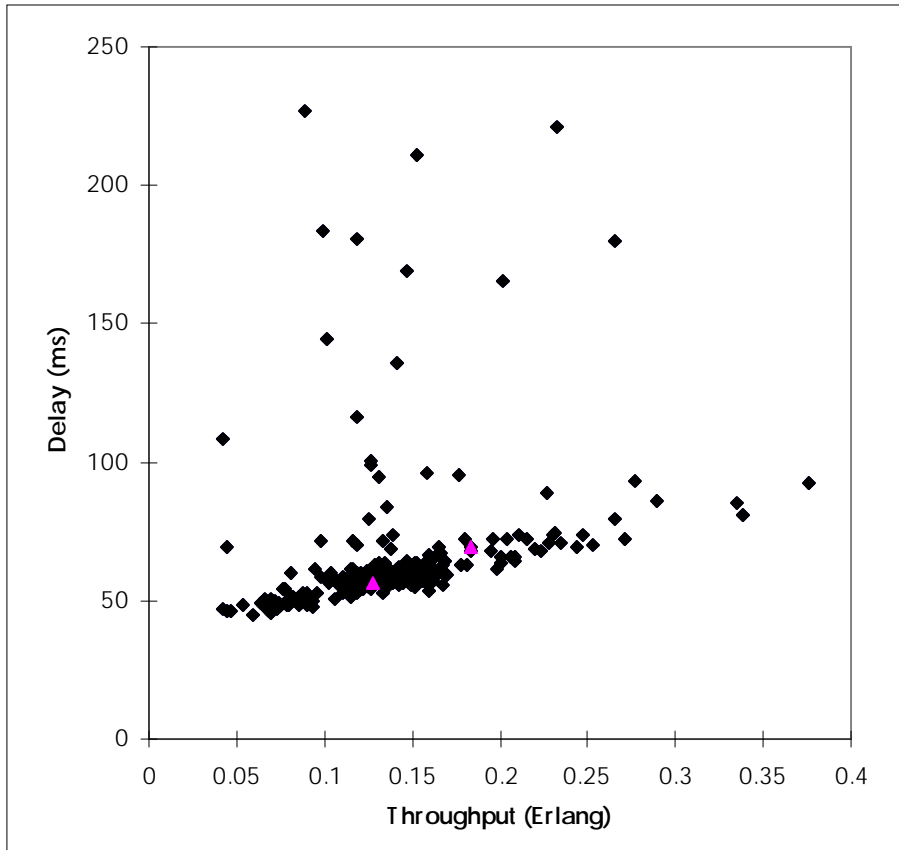
### 8.2.1.3.2 Peak-Period ITS plus Non-ITS

Simulating now the ITS plus non-ITS data loads, we increase the load substantially, but we still remain at almost half of the load assessed in Phase I for the 2012 time frame. Looking first at the Average Delay and Standard Deviation as a function of packet length in Figure 8.2-10, we observe the same behavior identified above – almost linear increase of average delay with packet length, and decreasing normalized standard deviation.



**Figure 8.2-10 Average Delay and Standard Deviation as a Function of Packet Length**

The delay observed in Figure 8.2-11 is obviously somewhat higher than before, given that the reverse link load increased by a factor of 3.5, but not by much. We are still in the almost constant delay portion of the Delay-Throughput “curve” identified in Section 8.2.1.1. Now, 10 out of the 230 sectors have delays above 150 ms.



**Figure 8.2-11 Delay-Throughput Pairs for Detroit 2002 for ITS plus Non-ITS**

Figure 8.2-12 presents a color-coded delay map of Detroit for the case of ITS plus non-ITS loads.

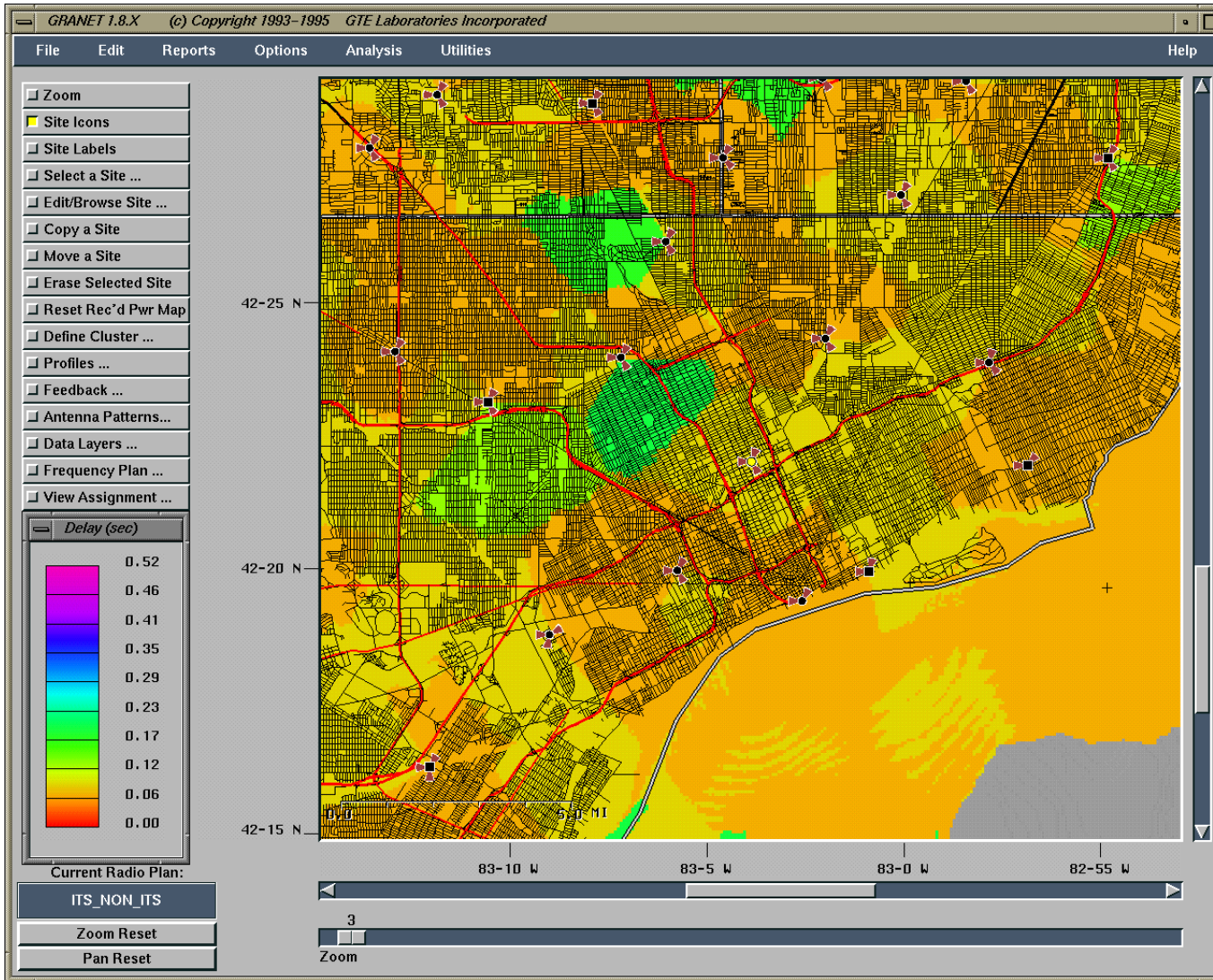
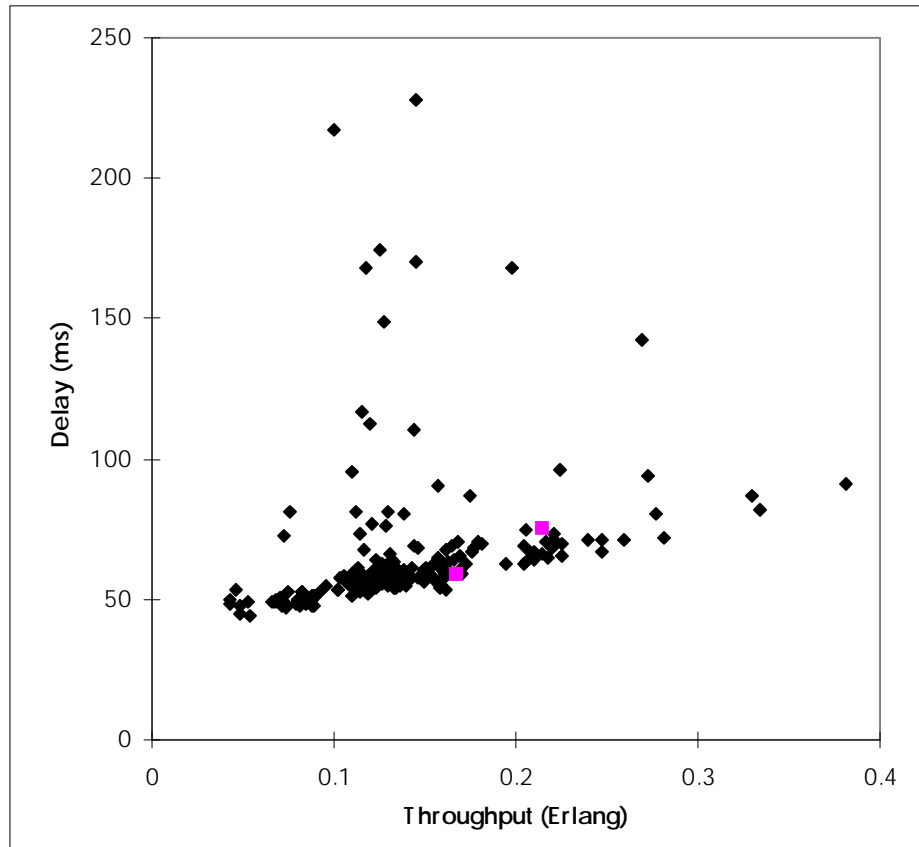


Figure 8.2-12 ITS plus Non-ITS CDPD Reverse Link Delay for Urbansville 2002

### 8.2.1.3.3 Peak-Period ITS plus Non-ITS with Incident

In Phase I, a worst case type incident was modeled but not specifically for Detroit. In Phase II, an accident occurring in the CBD of the Detroit scenario was simulated with “incident loads” obtained from MITRE from their vehicular traffic simulations.

We now analyze the impact of an incident on the CDPD performance. The average delay in the affected sectors and in those in the immediate vicinity will be compared with those in absence of the incident. For convenience, the two sectors affected by the incident have been signaled in Figure 8.2-13 (gray instead of black) to make it easier to compare with the results in Figure 8.2-13 for the case of incident.



**Figure 8.2-13 Delay-Throughput Pairs for Detroit 2002 for ITS plus Non-ITS in case of Incident**

In the two sectors affected by the incident, the delay increased by a factor of 3.9% in the Tiger Stadium #1 sector, and by a factor of 7.95% in the Baltimore #3 sector. On the other hand, comparing the above result with the one in absence of incident, we notice considerable fluctuation of the observed pairs, due to a natural statistical variation of the observed traffic from one simulation run to another. That fluctuation makes the delay increase in the affected sectors almost meaningless (statistically insignificant). Again, the fact that we are in the “flat” portion of the curve makes the increase in delay due to the increase in load very small, and thus is buried in the statistical fluctuation.

Figure 8.2-14 presents a color-coded delay map of Detroit for the case of ITS plus non-ITS loads with incident affecting two of the downtown sectors.

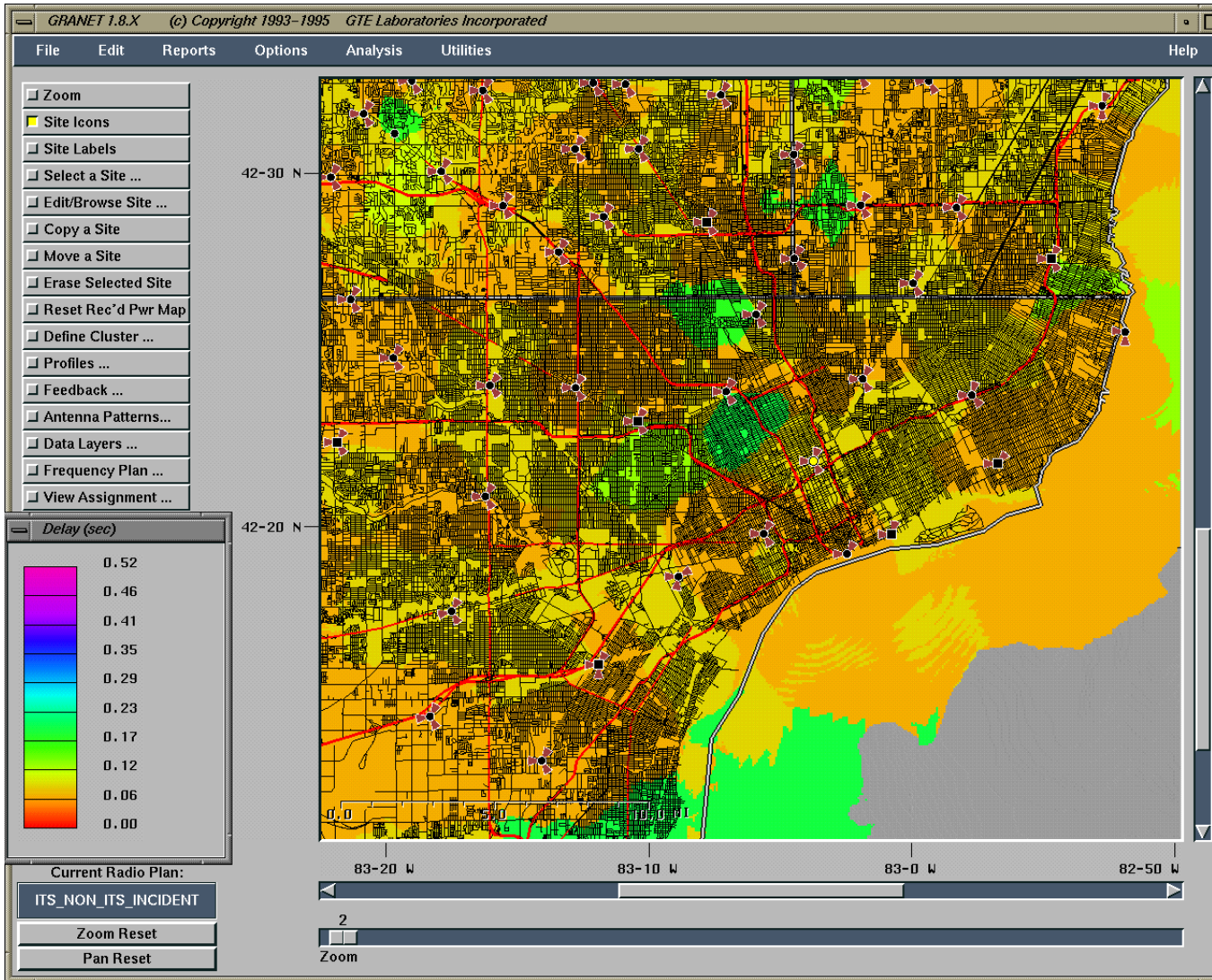


Figure 8.2-14 ITS plus Non-ITS with Incident CDPD Reverse Link Delay for Urbansville 2002

#### **8.2.1.4 Urbansville 2002 -- Dynamic Assignment of CDPD Channels (No Reserved Channel)**

When the CDPD was initially conceived, the idea was to make exclusive use of the idle periods between voice calls. In order to be able to do that, the MD-BS either has a connection to the Mobile Switching Office (the AMPS switch), or has to implement “sniffing”, which is forward-sensing the channels that are momentarily not in use.

A simpler method would be to reserve a channel for CDPD exclusive use, either by adding a new channel to the existing grouping, or by subtracting one from voice. The latter alternative is in general only temporary, since all cellular providers keep checking blocking probability, and adding channels whenever it begins to approach the dreaded 2%.

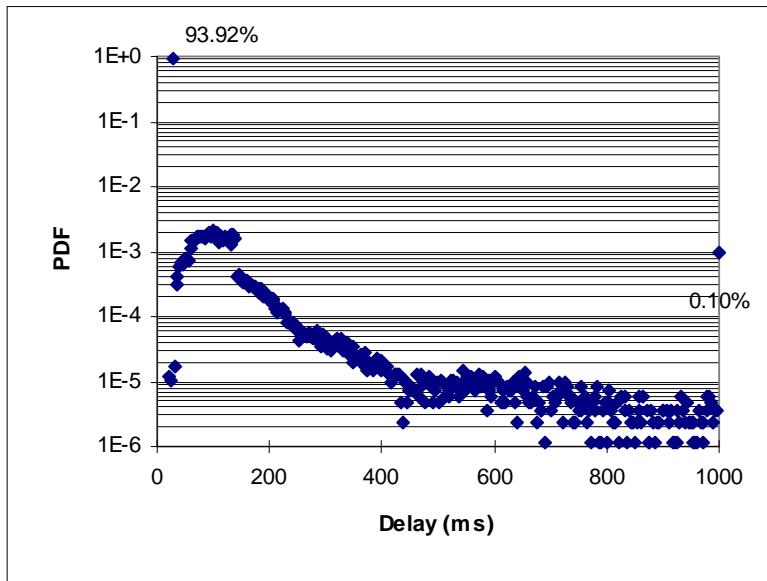
The previous section looked into the performance of a system with a reserved CDPD channel in each sector, the so called minimal CDPD deployment. Here we are going to analyze the case where no channel is reserved for CDPD, and only the idle periods are used.

Well established queuing theory results indicate that for a properly designed cellular network with a reasonable number of channels per sector, which is always the case for urban environments, three CDPD channels can capture, during the peak period, almost all the idle periods in the voice channels, and a fourth would have minimal impact (very quickly diminishing returns). It should be noted that the cost of three CDPD channels per sector is considerably less than adding a new voice channel to each sector.

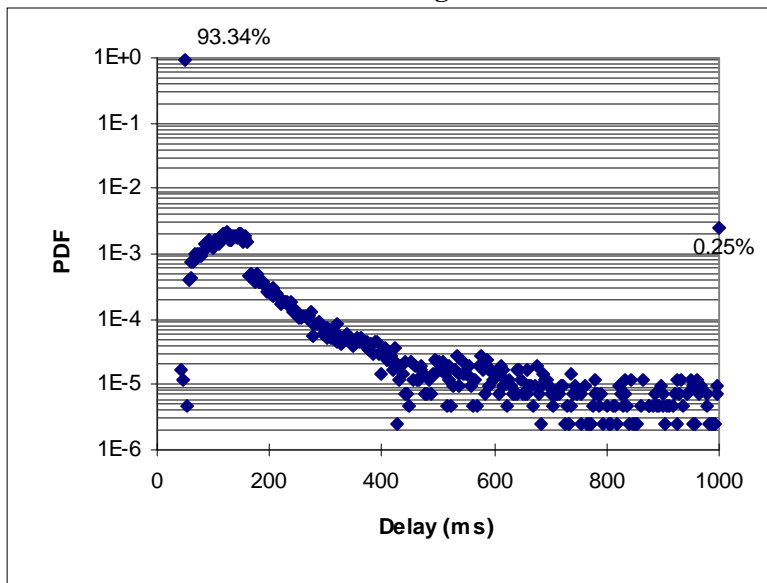
The performance of a 3-Dynamic CDPD channels (No Reserved) deployment will be assessed for the ITS plus non-ITS data Loads for the Detroit scenario. The resulting system performance is slightly better than that of the One Reserved CDPD channel minimal deployment.

##### **8.2.1.4.1 System Performance for 3-Dynamically Assigned CDPD Channels**

Figure 8.2-15 shows the delay PDF's obtained for a totally dynamic deployment. The observed PDF's are quite different from those obtained for one reserved CDPD channel. It is quite apparent the smaller standard deviation of the delay that results from the availability of in general more than one channel for re-transmission in case of back-off due to collision or in case of packet error (remaining traffic has alternative channels for delivery, and simultaneously is less likely to interfere with the re-trials).



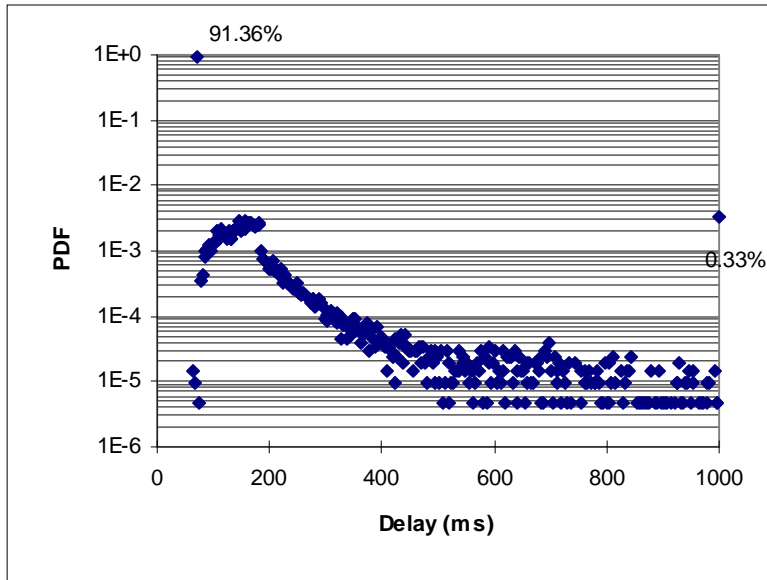
**1 RS-block Long Packets**



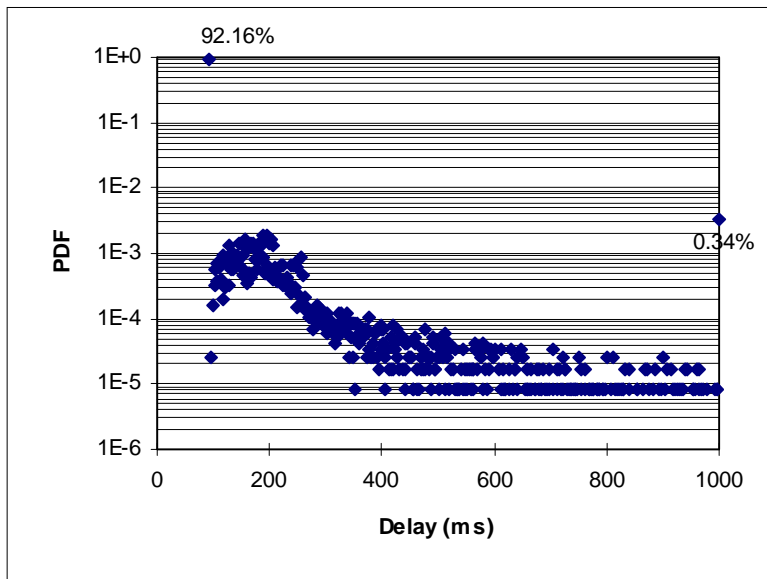
**2 RS-block Long Packets**

**Figure 8.2-15 Delay PDF's as a Function of the Packet Length in RS-blocks, for 3-Dynamically Assigned CDPD Channels (No Reserved) for ITS+Non-ITS Data Loads**



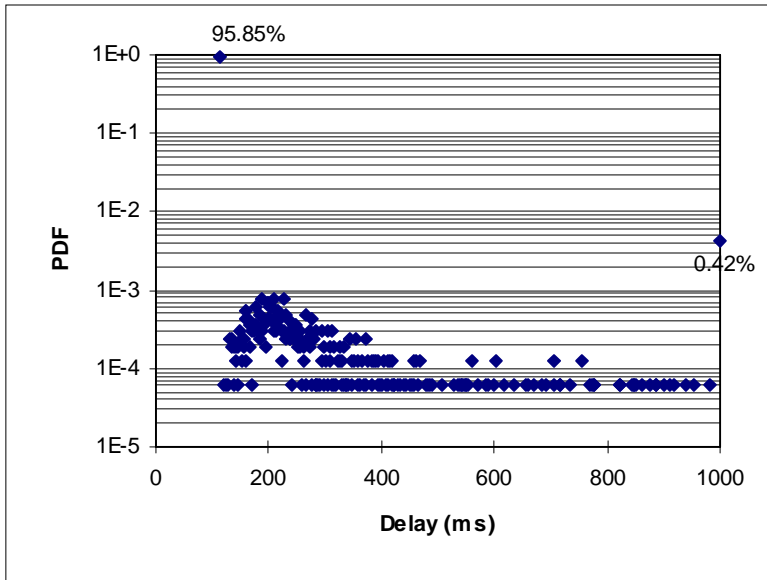


**3 RS-block Long Packets**



**4 RS-block Long Packets**

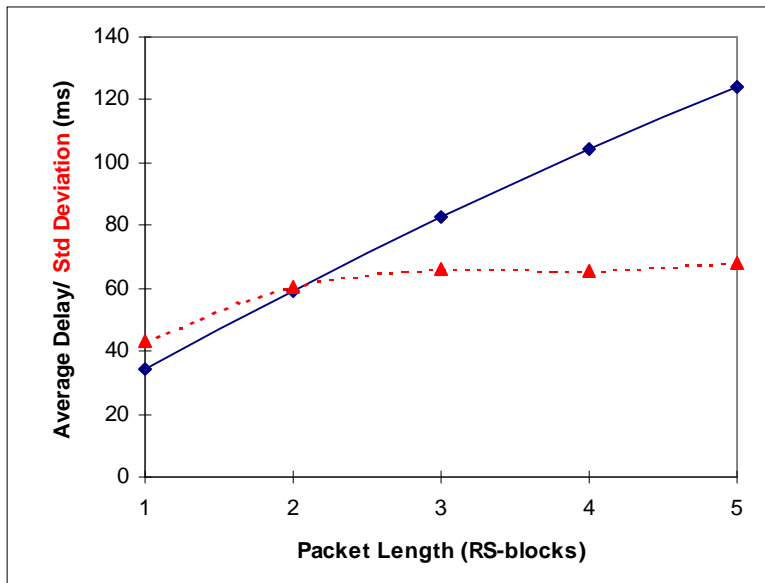
**Figure 8.2-15 (Con't) Delay PDF's as a Function of the Packet Length in RS-blocks, for 3-Dynamically Assigned CDPD Channels (No Reserved) for ITS+Non-ITS Data Loads**



**5 RS-block Long Packets**

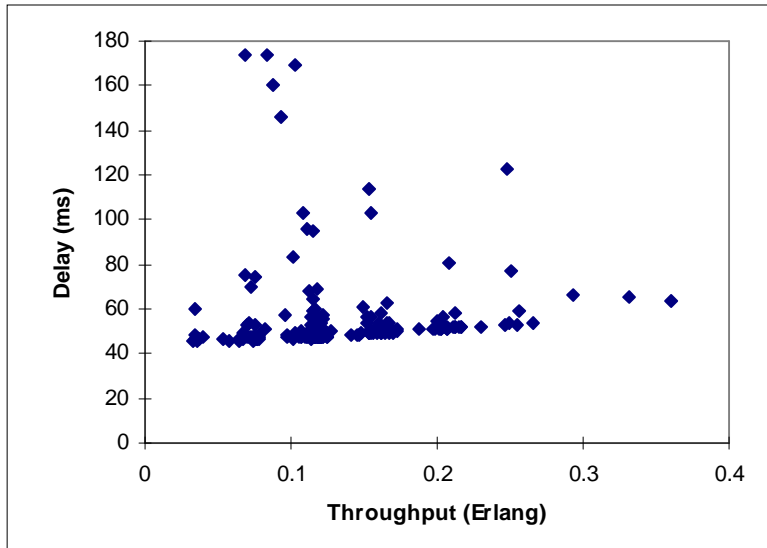
**Figure 8.2-15 (Con't) Delay PDF's as a Function of the Packet Length in RS-blocks, for 3-Dynamically Assigned CDPD Channels (No Reserved) for ITS+Non-ITS Data Loads**

Figure 8.2-16 shows the behavior we came to expect. Also note the nearly perfect linear relation of Average Delay to Packet Length (driven by the channels fixed data rate).



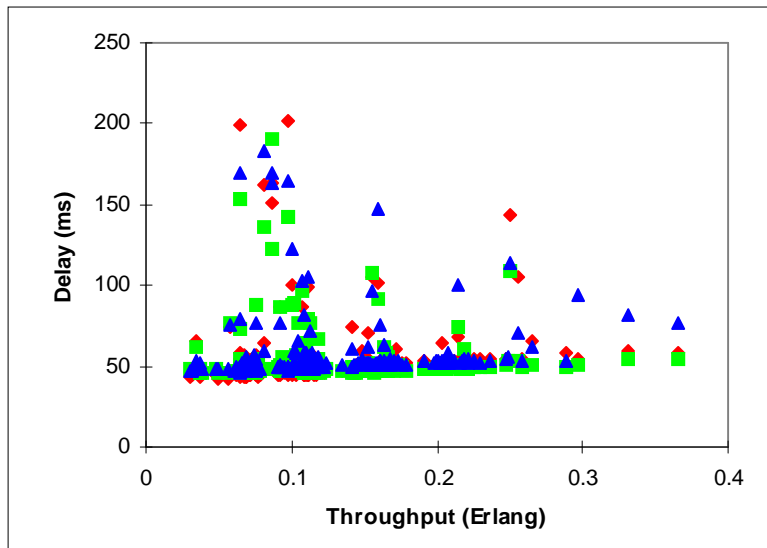
**Figure 8.2-16 Average Delay and Standard Deviation for 3-Dynamically Assigned CDPD Channels**

Figure 8.2-17 shows the Delay-Throughput pairs for this totally dynamic deployment. The delay is obviously much smaller than in the case of One Reserved CDPD Channel, and the “curve” is now even flatter.



**Figure 8.2-17 Delay-Throughput for 3-Dynamically Assigned CDPD Channels (No Reserved) for ITS+Non-ITS Data Loads**

Since we had noticed fluctuations in the case of One Reserved channel, we looked at three distinct runs of the Dynamic Deployment for the Detroit scenario. The statistical fluctuations are here smaller (Figure 8.2-18), reflecting the increased number of channels available on average for transmission.



**Figure 8.2-18 Delay-Throughput Pairs Observed in Three Different Simulation Runs for 3-Dynamically Assigned CDPD Channels (No Reserved) for ITS+Non-ITS Data Loads**

Figure 8.2-19 shows a color-coded delay map of Detroit for the case of ITS plus non-ITS loads for this dynamic deployment.

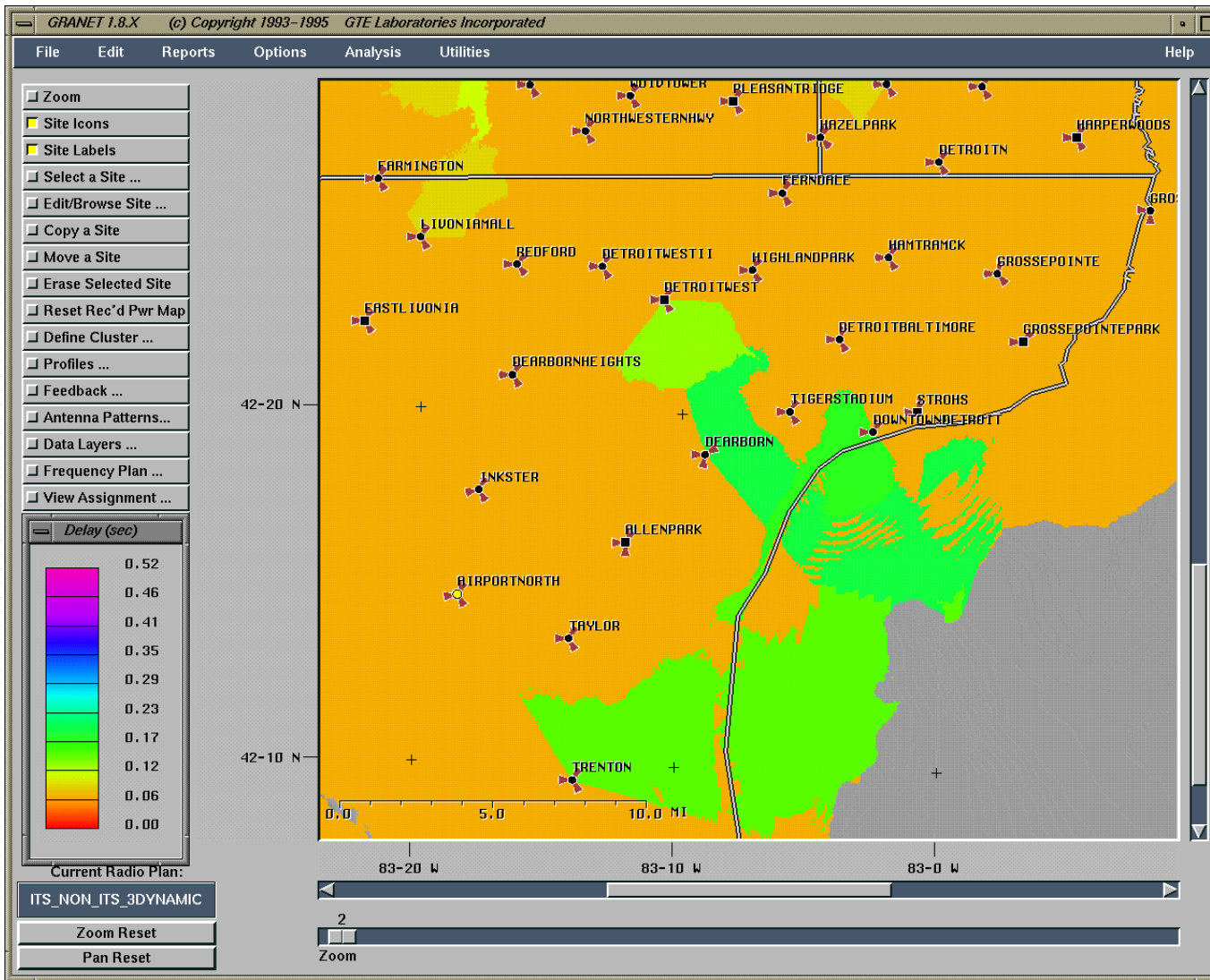


Figure 8.2-19 CDPD Reverse Link Delay for ITS plus Non-ITS Data Loads and 3-Dynamically Assigned CDPD Channels

### **8.2.2 Thruville 2002**

Coverage for the present cellular deployment, as well as best server information, (obtained using GRANET), is shown in Figure 8.2-20.

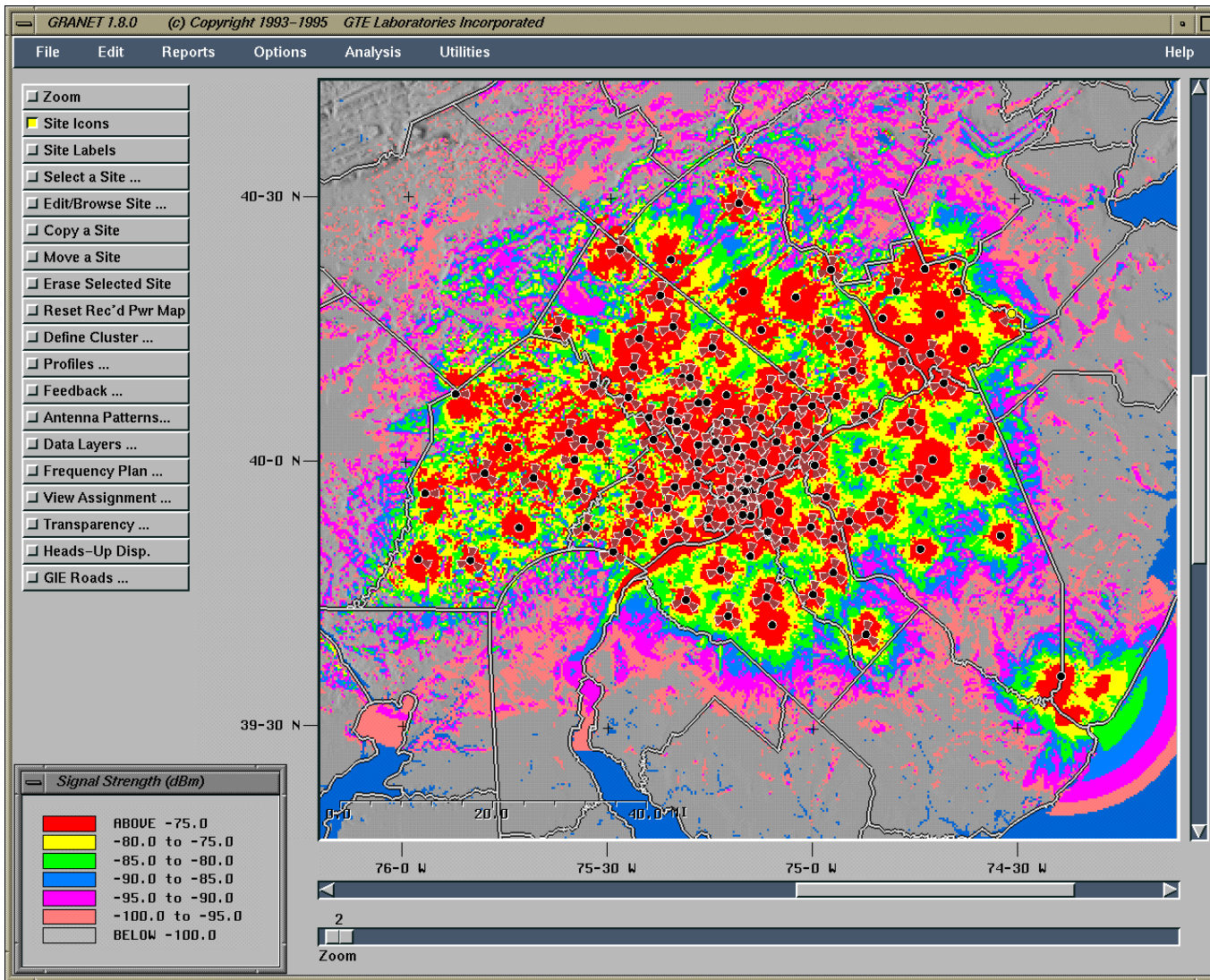
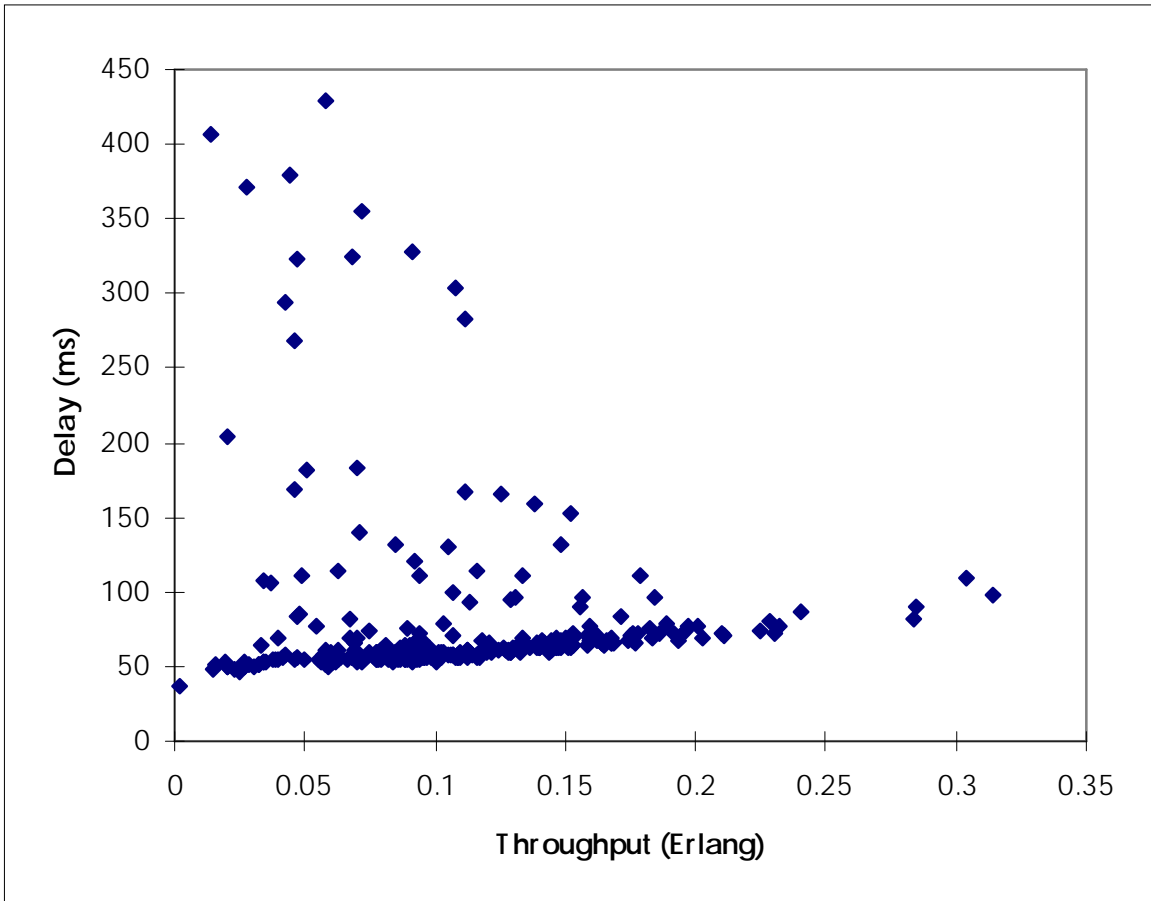


Figure 8.2-20 Philadelphia-Trenton Corridor (Thruville) Coverage

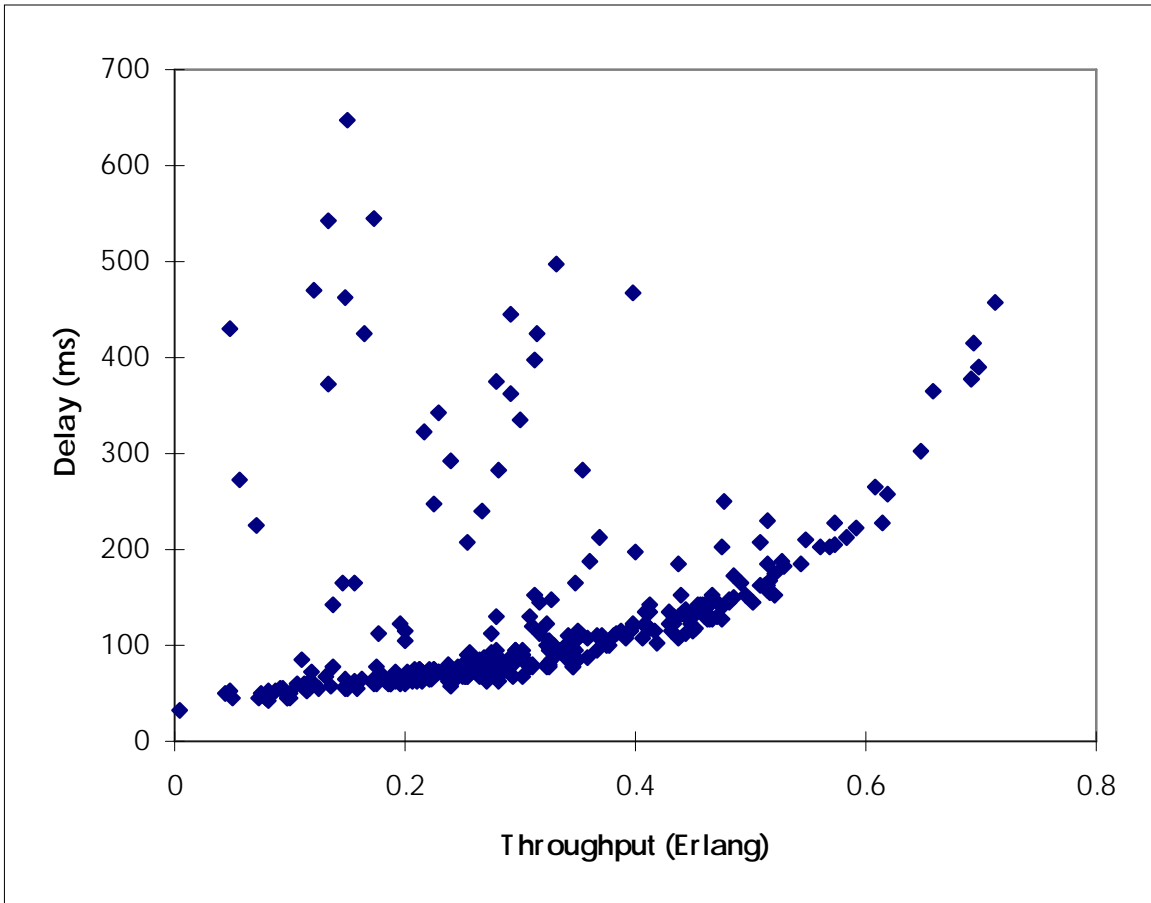
For the data loads identified in Section 8.1.5, performance information was obtained for the cases of ITS Only, and ITS plus non-ITS. As in the previous cases for the Detroit cellular scenario, we observe for the Philadelphia-Trenton cellular deployment, updated in March 1995, a few sectors that deviate from the expected Delay-Throughput curve.

Figure 8.2-21 shows that, for the small loads associated with ITS only, almost all sectors fall in the “linear”, almost flat portion of the Delay-Throughput curve. Out of the 333 sectors in the scenario, only 13 have delays above 200 ms.



**Figure 8.2-21 Delay-Throughput Pairs for ITS Only Data Loads for Thruville 2002**

Figure 8.2-22 shows the performance of the system for ITS plus non-ITS Data Loads. We observe that almost all the Delay-Throughput curve is now filled. Exactly the same number of sectors, 13, is now above 400 ms (two times 200 ms), when the reverse link load increased by a factor of 3.5.



**Figure 8.2-22 Delay-Throughput Pairs for ITS plus Non-ITS Data Loads for Thruville 2002**

As stated before, we had no opportunity to explore the effects of the incident “created” by the Government. However, comparing the Thruville incident scenario with that of Urbansville, we can expect that the increase in data load due to the incident be, per cent-wise, even smaller in this case. This is in part because the incident expands over a much bigger region, and therefore it takes that much longer to build the queues that were observed in MITRE’s simulation just before the incident began to clear. As a result, the increase in delay due to the (small) increase in load will, in all likelihood, be masked in the statistical fluctuation of the simulation.

### 8.2.3 Mountainville

Information on the cellular coverage in the Lincoln County, Montana area was used to compute the associated cellular coverage. *A priori*, full coverage of the area under consideration was not expected – the relief and the low population density are such that only the major highways and population concentrations have been targeted for coverage. However, looking at the obtained coverage information, we see that only a few deep valleys are not covered. The coverage for Mountainville is shown in Figure 8.2-23.



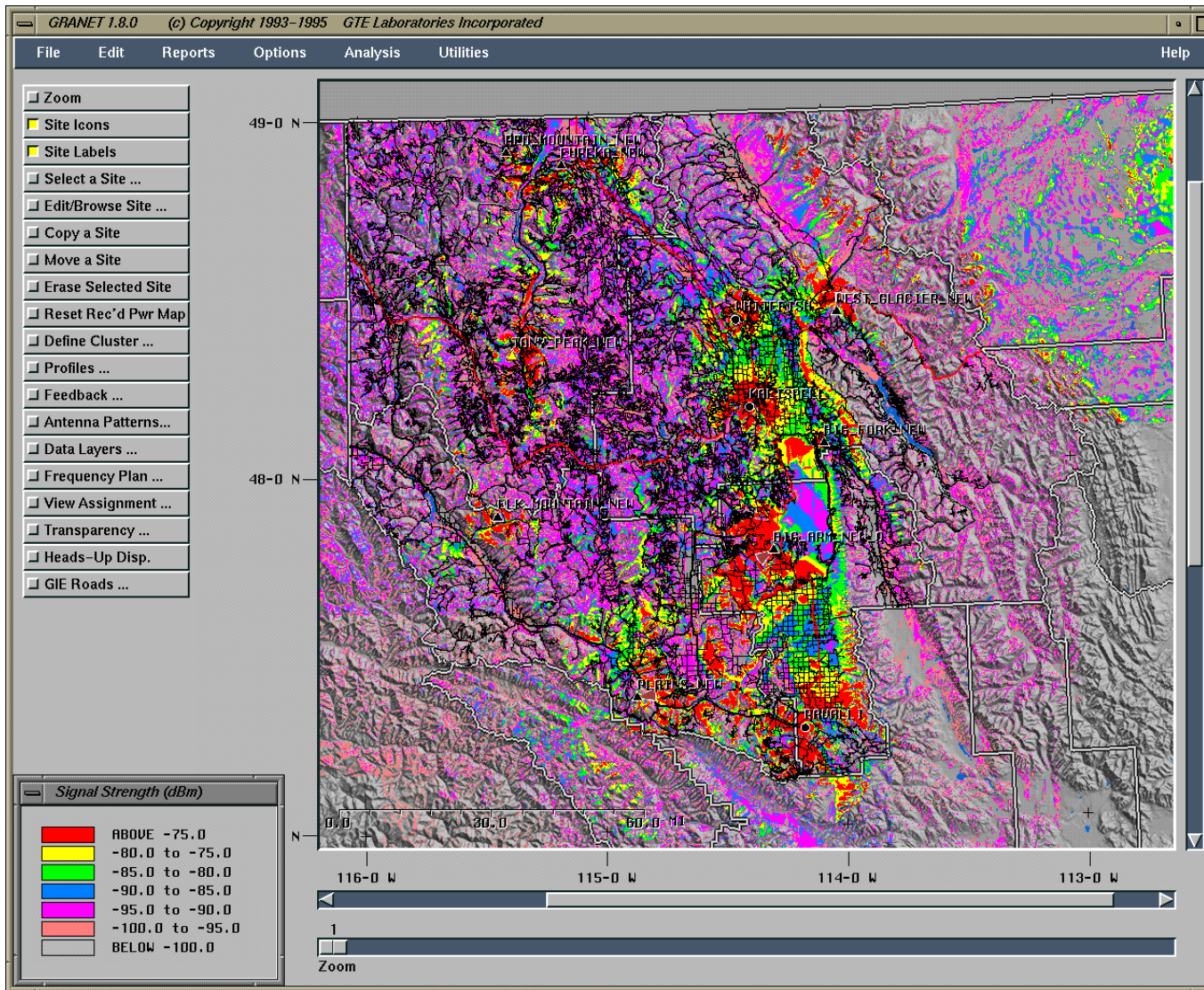


Figure 8.2-23 Lincoln County, Montana (Mountainville) Coverage

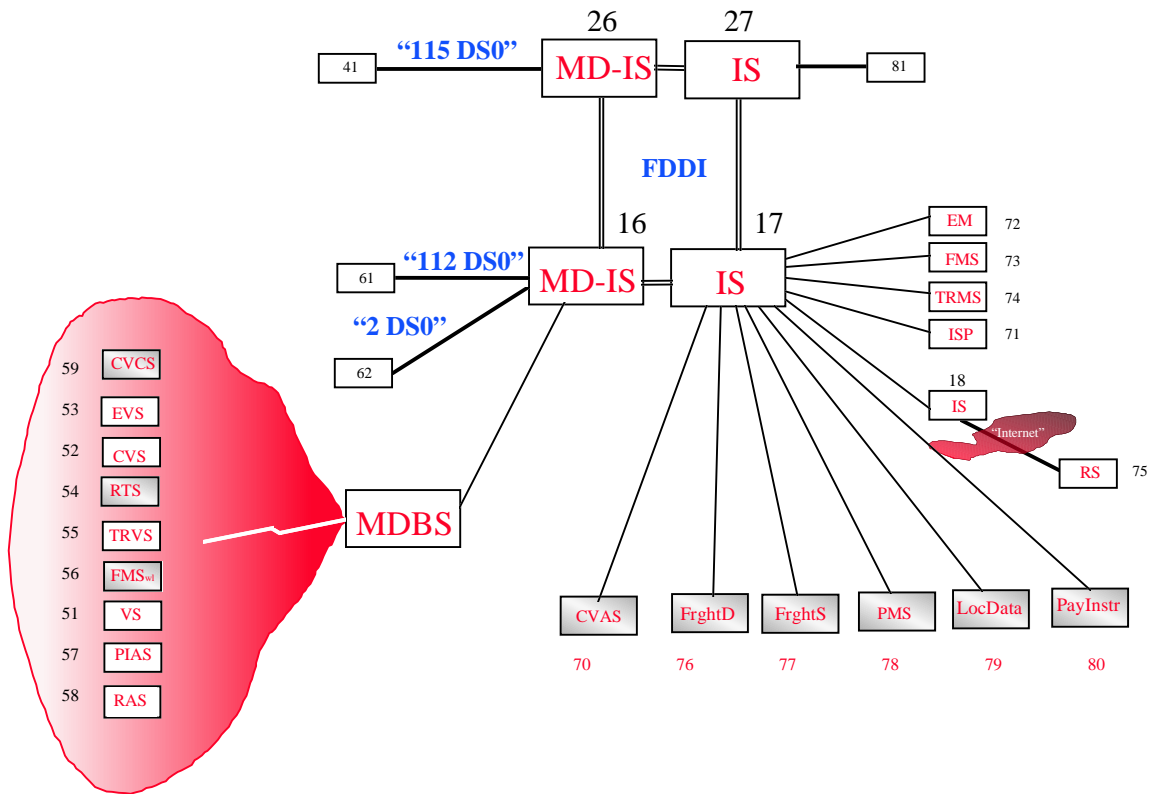
### **8.3 Wireline System Performance**

Simulations of wireline networks were performed in Phase I (see Phase I Document: *Analysis of Data Loading Requirements*). The results showed that for communication among ITS subsystems the delay of a reasonably designed network, with readily available technology, is extremely small (microseconds) and insignificant. Consequently, in Phase II the wireline simulation focused on the wireline component of the CDPD network in order to obtain end-to-end system performance, including the effect of the higher layers of the protocol stack.

#### **8.3.1 Traffic Over the Wireline Portion of the CDPD Network**

Figure 8.3-1 shows the network to be simulated to assess the true end-to-end performance of the CDPD network. It takes into account all the CDPD traffic in the Urbansville area. It is based on the cellular deployment information already collected (230 sectors in 80 sites), and essentially follows the Rockwell Team's Evaluatory design of Phase I: three jurisdictions; two MD-IS's approximately splitting the control of the sites; two TMS's; and three (or possibly only two) ISP's. One of the TMS's, as well as one of the ISP's see higher concentration of traffic since they cover the CBD of Detroit. Those will be therefore selected for the worst-case end-to-end performance study.

In order to simplify the analysis, all users of a given type (of one of the groups identified above) will be treated as a composite source with the equivalent traffic. We will then identify the traffic that originates and terminates at each mobile user group destined to and arriving from each of the F-ES's of interest. In addition to the ISP, we have to consider the FMS, TRMS, EM, CVAS, PMS, and a few externals, like Pay Instrument, Location Data, and Intermodal Freight Depot/Shipper.



**Figure 8.3-1 Network to be Simulated to Assess End-to-End Performance**

Figure 8.3-2 shows the M-ES/F-ES Origin-Destination pairs of interest which will be simulated. Included are the non-ITS users (Remote Access - RAS) that also use the CDPD network to remotely access their home systems, mainly for the purpose of retrieving e-mail messages.

**Figure 8.3-2 M-ES/F-ES Origin-Destination Pairs**

Table 8.3-1 describes the traffic between ITS pairs, thus enabling an accurate simulation of the CDPD network performance in the Urbansville area.

**Table 8.3-1 ITS Origin-Destination Pairs Traffic (RS-blocks/s/Sector)**

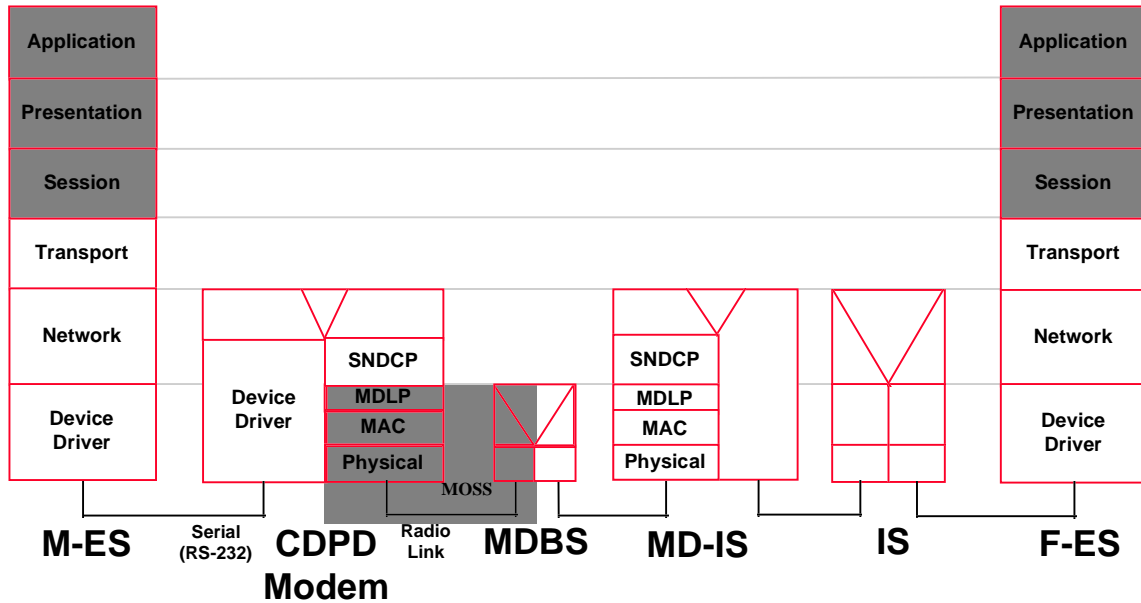
		<<<<Forward	F1	F2	F3	F4	F5	Reverse>>>>	R1	R2	R3	R4	R5
CVCS	CVAS	0.000			0.000	0.000		0.000		0.000	0.000	0.000	
FMS	CVAS	0.003		0.001	0.002	0.000		0.004			0.002	0.002	
FMS	EM	0.000		0.000				0.000	0.000	0.000	0.000		
FMS	ImFrghtD	0.000				0.000		0.000				0.000	
FMS	ImFrghtS	0.000				0.000		0.000				0.000	
FMS	ISP	0.149	0.009	0.084	0.019	0.028	0.009	0.103	0.047	0.037		0.019	
FMS	PayInstr	0.000		0.000				0.000		0.000			
PIAS	EM	0.000		0.000				0.000			0.000		
PIAS	ISP	0.032	0.002	0.000	0.020	0.006	0.003	0.006	0.000	0.002	0.004		0.000
PIAS	LocData	0.000		0.000									
PIAS	PayInstr	0.000			0.000			0.000		0.000			
PIAS	TRMS	0.001		0.001				0.000				0.000	
RTS	EM							0.000			0.000		
RTS	ISP	0.000			0.000	0.000	0.000	0.001		0.001	0.000	0.000	0.000
RTS	PayInstr	0.000		0.000	0.000			0.000		0.000			
CVS	FMS	0.234	0.074	0.057	0.057	0.009	0.037	0.175	0.042	0.132	0.000		
EVS	EM	0.018	0.012			0.006		0.029		0.023		0.006	
TRVS	PayInstr	0.004		0.004	0.000			0.009		0.009			
TRVS	TRMS	0.128	0.004	0.013	0.086	0.023	0.002	0.091	0.005	0.015	0.062	0.009	
VS	EM	0.000		0.000				0.000		0.000	0.000		
VS	ISP	0.210		0.095	0.092	0.024	0.000	0.045		0.006	0.037	0.002	
VS	LocData	0.001		0.001									
VS	PayInstr	0.000			0.000			0.000		0.000	0.000		
VS	PMS							0.000		0.000		0.000	
RAS	RS	6.513	3.473	1.380	1.026	0.414	0.220	1.897	0.938	0.507	0.293	0.117	0.042

## 8.4 End-to-End System Performance

### 8.4.1 Scope of Performance Analysis

The cellular simulation capabilities of GTE Laboratories (GTEL) are combined with Loral's protocol simulation capabilities to provide the end-to-end performance. GTEL's MOSS accurately characterizes the lower layers of the CDPD protocol (MAC and Physical in Figure 8.4-1) in the reverse direction by using accurate propagation information obtained from GRANET and by taking into account all the interference effects arising from both voice and data. Loral's OPNET model of the CDPD protocol is used to model the higher layers, and the forward link, given that it operates in a broadcast mode (i.e., no contention).

Figure 8.4-1 shows the protocol stack to be simulated. The first observation is that for most applications, the Session, Presentation and Application layers are merged together. Thus, end-to-end performance will be measured from the moment information is delivered to the Transport layer at the Mobile or Fixed End Systems (M-ES/F-ES) till the moment it is delivered by the Transport layer at the other end (F-ES/M-ES).



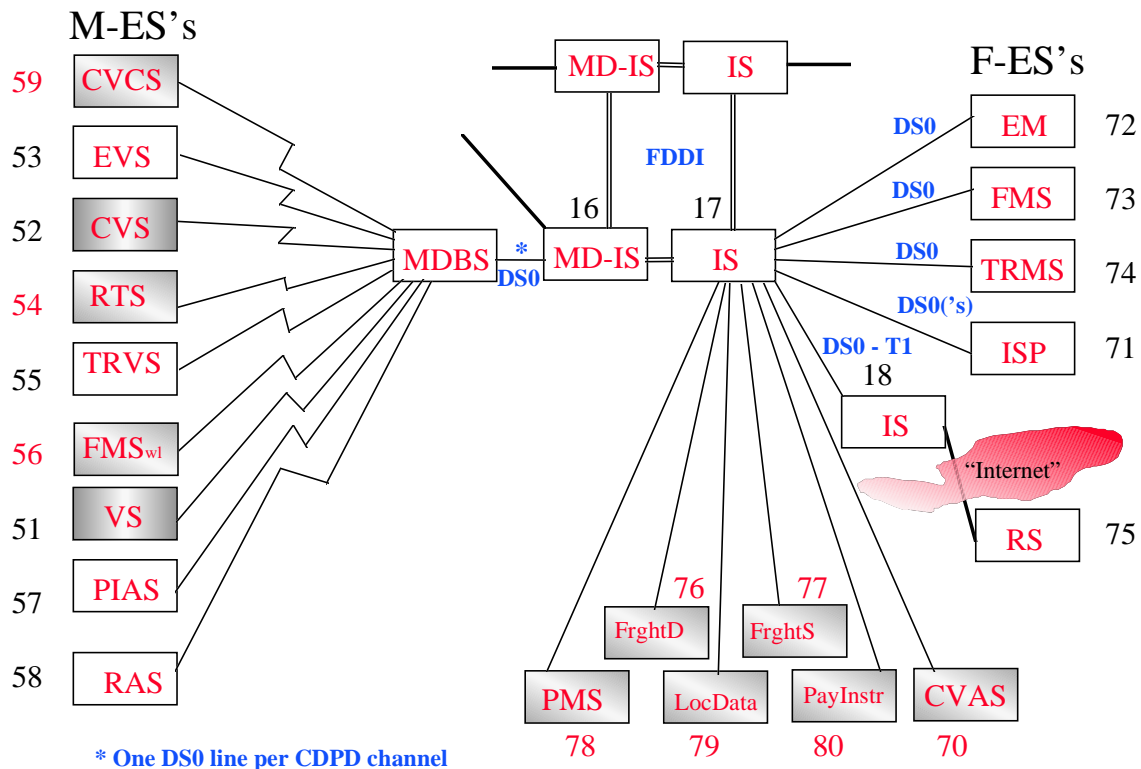
**Figure 8.4-1 CDPD Protocol Stack for End-to-End Performance Evaluation (Shows the Portion to be Replaced by MOSS' CDPD Traffic Characterization in Terms of Delay)**

The scope of MOSS (and GRANET) is clearly identified in Figure 8.4-1. The delay characterization of the CDPD reverse link will be used to account for the over-the-air delay. As a matter of fact, the lower layers of the CDPD protocol guarantee delivery of information from the M-ES to the MD-BS. MOSS does in fact "listen" to the forward channel to make sure it accounts for contention and other channel impairments as detected at the MD-BS.

With this integrated model (OPNET using the CDPD reverse channel characterization obtained from MOSS and GRANET), the Joint Team obtained end-to-end (application to application) CDPD delay information, thus answering some of the questions raised at the conclusion of Phase I. The performance of the CDPD networks deployed in Urbansville (based upon actual cellular deployment in the areas that inspired those scenarios) during the peak period was used for arriving at the end-to-end delay.

### 8.4.2 Results

Simulation results are obtained for the important segments of the overall CDPD network – emphasizing non-ITS users, and the effect of the overall traffic in the CDPD network. See Figure 8.4-2.



**Figure 8.4-2 Portion of the CDPD Network that has been Simulated (Corresponding to One Sector of the Cellular Deployment)**

The choice of specific links in the simulation (DS0 and T1) is determined by the expected traffic to and from the aggregated F-ES's for the various service groupings.

Table 8.4-1 presents the cumulative traffic to and from the F-ES's. It can be seen that, except for the Emergency Management and Transit Management subsystems, which can do with a DS0 line (56 kbps capacity), all others need to have a higher capacity connection. In most cases, this higher capacity will be achieved by leasing a few DS0 lines, allowing for flexibility in adding more, whenever needed while paying only for the required throughput, instead of going directly to fractional T1 or even T1 lines.

**Table 8.4-1 Total Traffic Departing from/Arriving at the F-ES's**

<b>1 Sector</b>													
Origin	Dest	<<<<Forward	F1	F2	F3	F4	F5	Reverse>>>>	R1	R2	R3	R4	R5
	CVAS	0.003		0.001	0.002	0.000		0.004		0.000	0.002	0.002	
	EM	0.018	0.012	0.000		0.006		0.029		0.023	0.000	0.006	
	FMS	0.234	0.074	0.057	0.057	0.009	0.037	0.175	0.042	0.132	0.000		
	ImFrghD	0.000				0.000		0.000				0.000	
	ImFrghS	0.000				0.000		0.000				0.000	
	ISP	0.391	0.011	0.179	0.131	0.058	0.013	0.155	0.047	0.046	0.041	0.020	0.000
	LocData	0.001		0.001									
	PayInstr	0.005		0.005	0.000			0.009		0.009	0.000		
	PMS							0.000		0.000		0.000	
	RS	6.513	3.473	1.380	1.026	0.414	0.220	1.897	0.938	0.507	0.293	0.117	0.042
	TRMS	0.129	0.004	0.014	0.086	0.023	0.002	0.091	0.005	0.015	0.062	0.009	
<b>2 Sector Load</b>													
#62	Dest	<<<<Forward	F1	F2	F3	F4	F5	Reverse>>>>	R1	R2	R3	R4	R5
	CVAS	0.006		0.001	0.004	0.001		0.007		0.000	0.003	0.004	
	EM	0.035	0.023	0.000		0.012		0.059		0.047	0.000	0.012	
	FMS	0.468	0.148	0.114	0.113	0.019	0.074	0.349	0.085	0.264	0.001		
	ImFrghD	0.001				0.001		0.001				0.001	
	ImFrghS	0.001				0.001		0.001				0.001	
	ISP	0.782	0.022	0.357	0.262	0.116	0.025	0.309	0.094	0.092	0.082	0.041	0.000
	LocData	0.003		0.003									
	PayInstr	0.010		0.010	0.000			0.019		0.019	0.000		
	PMS							0.000		0.000		0.000	
	RS	13.025	6.946	2.761	2.051	0.828	0.441	3.793	1.876	1.014	0.585	0.234	0.085
	TRMS	0.258	0.007	0.028	0.173	0.047	0.004	0.183	0.011	0.030	0.124	0.017	
<b>112 Sector Load</b>													
#61	Dest	<<<<Forward	F1	F2	F3	F4	F5	Reverse>>>>	R1	R2	R3	R4	R5
	CVAS	0.330		0.072	0.221	0.036		0.410		0.001	0.181	0.228	
	EM	1.972	1.312	0.004		0.656		3.295		2.630	0.009	0.656	
	FMS	26.195	8.293	6.364	6.346	1.046	4.147	19.561	4.759	14.765	0.036		
	ImFrghD	0.054				0.054		0.054				0.054	
	ImFrghS	0.054				0.054		0.054				0.054	
	ISP	43.818	1.243	20.012	14.668	6.473	1.422	17.308	5.248	5.153	4.594	2.293	0.020
	LocData	0.152		0.152									
	PayInstr	0.564		0.540	0.024			1.060		1.060	0.000		
	PMS							0.004		0.002		0.002	
	RS	729.421	388.954	154.590	114.858	46.344	24.675	212.431	105.030	56.772	32.769	13.118	4.741
	TRMS	14.439	0.397	1.543	9.663	2.615	0.222	10.223	0.595	1.685	6.965	0.979	
<b>115 Sector Load</b>													
20% goes to the F-ES's of the other region													
#41	Dest	<<<<Forward	F1	F2	F3	F4	F5	Reverse>>>>	R1	R2	R3	R4	R5
	CVAS	0.068		0.015	0.045	0.007		0.084		0.000	0.037	0.047	
	EM	0.405	0.269	0.001		0.135		0.677		0.540	0.002	0.135	
	FMS	5.379	1.703	1.307	1.303	0.215	0.852	4.017	0.977	3.032	0.007		
	ImFrghD	0.011				0.011		0.011				0.011	
	ImFrghS	0.011				0.011		0.011				0.011	
	ISP	8.998	0.255	4.110	3.012	1.329	0.292	3.554	1.078	1.058	0.943	0.471	0.004
	LocData	0.031		0.031									
	PayInstr	0.116		0.111	0.005			0.218		0.218	0.000		
	PMS							0.001		0.000		0.000	
	RS	149.792	79.875	31.746	23.587	9.517	5.067	43.624	21.569	11.659	6.729	2.694	0.974
	TRMS	2.965	0.082	0.317	1.984	0.537	0.046	2.099	0.122	0.346	1.430	0.201	
#41	#81	671.107	328.735	150.549	119.749	47.049	25.025	217.186	94.984	67.413	36.598	14.280	3.911

Preliminary simulation results are available and they are presented below for some of the O-D pairs previously identified. We account separately for the traffic in both directions. The main justification for this approach, besides the resulting simplification of the simulation effort, is that as stated at the outset, we are only taking into account the communication delay, and not the ITS Subsystems performance. The overall end-to-end delay can thus be approximated by adding to the independent delays in both directions, and then providing a margin for the expected processing and information access times at the F-ES's.

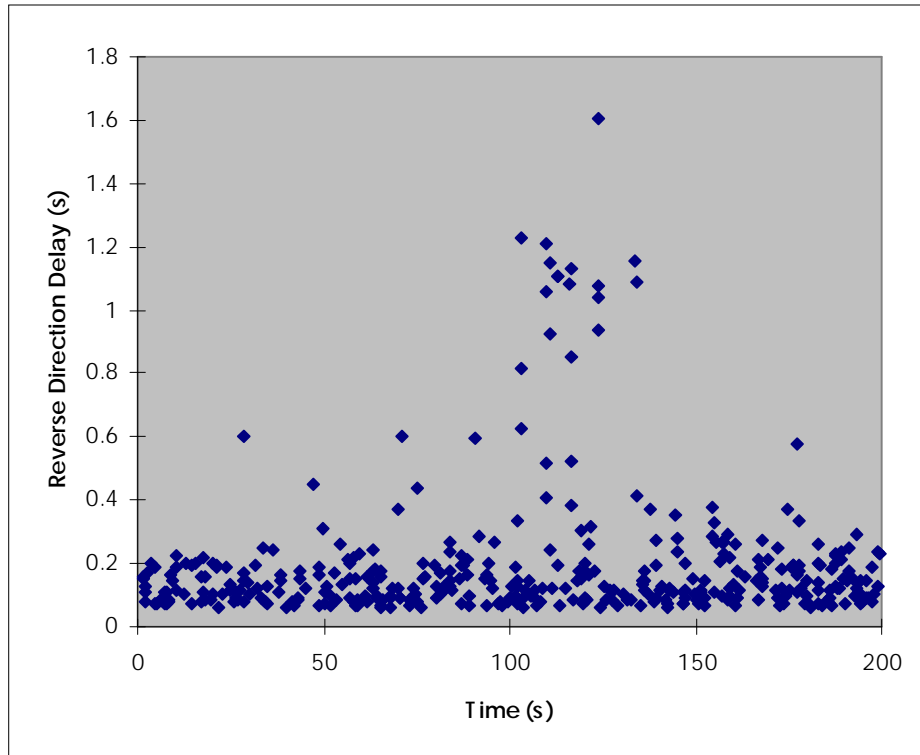
Figures 8.4-3 to 8.4-7 show the delay in both directions for the most relevant M-ES/F-ES O-D pairs: Private Vehicle-ISP, CVO Local-FMS, and RAS-RS, **assuming an initial period of 100 s with no packet loss followed by 40 s of 10% packet loss and then 60 s again with no packet loss**. Lost packets will eventually be retransmitted, as soon as the TCP timers at either end expire. This implies necessarily an increase in the overall CDPD traffic. As a first approximation, we can assume that there is a resulting 10% increase in the traffic in both directions between RAS and RS. Due to time and resource constraints, it was not possible to recompute the reverse link CDPD delay for this higher traffic, so the same CDPD delay distribution was used over the whole observation period. From all the analysis in Section 8.1 and 8.2, we are confident that the increase in delay due to this additional traffic would be minimal, since we are operating in a lightly loaded network.

Figure 8.4-3 shows the delay for the link directly affected by the packet loss. The increase in delay due to retransmission is obvious. However, the effect of the increase in traffic shows up on the other links: Figures 8.4-4 to 8.4-7 not only show a slight increase in delay, but hint at a slow recovery of the network.

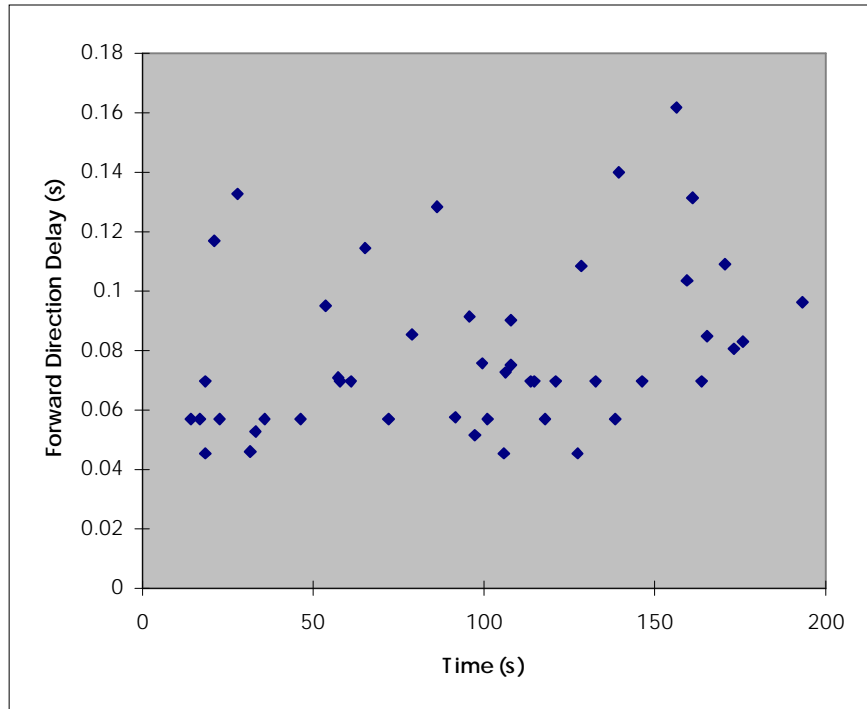
In any case, the reverse link (including the CDPD Reverse Link) has higher delays, as expected, due to the contention mechanism involved.

In all cases, the delay is still quite small, less than 2 seconds, which is well within the delay requirements of the various ITS services employing wide area wireless/wireline information exchange.

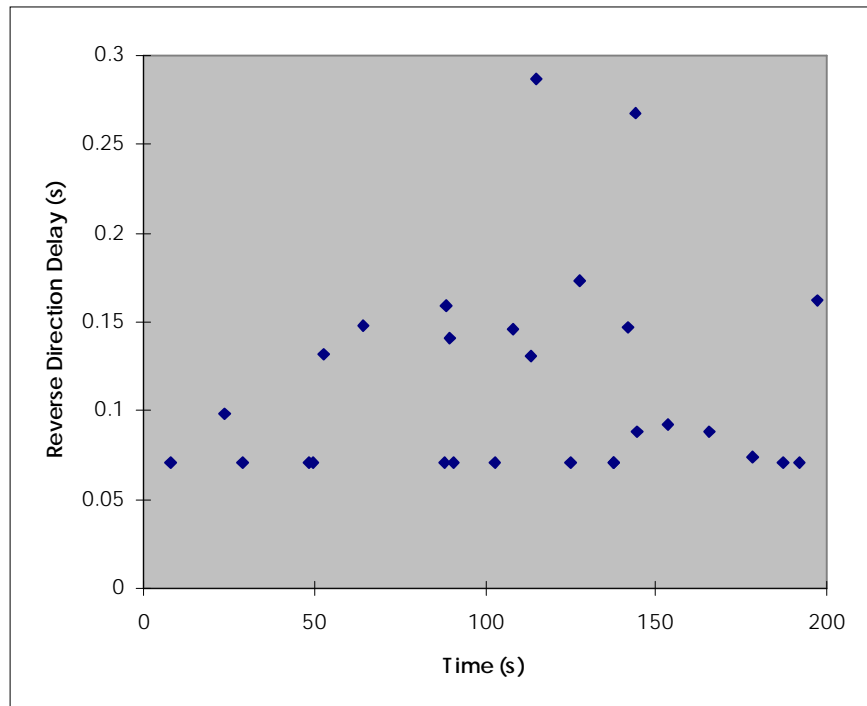




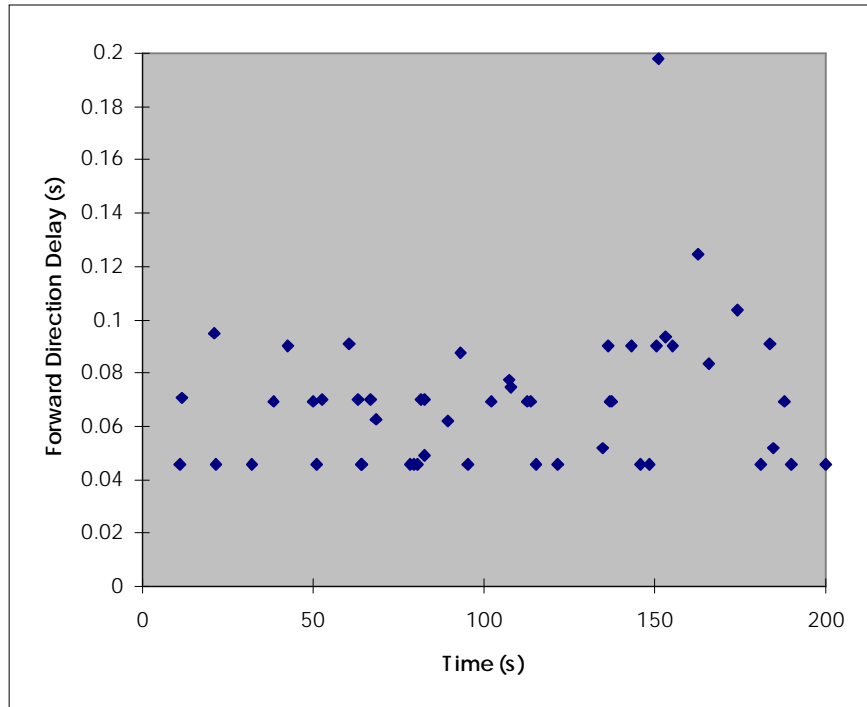
**Figure 8.4-3 RAS -> RS (Reverse Link) Assuming 100 s with No Packet Loss followed by 40 s with 10% Packet Loss, and then 60 s with No Packet Loss**



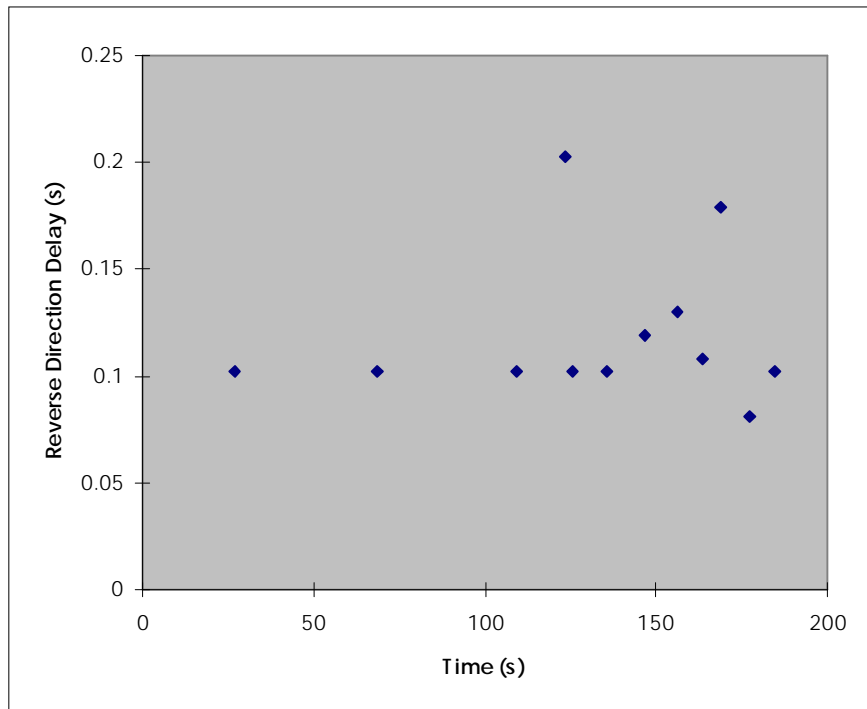
**Figure 8.4-4 FMS -> CVO Local (Forward Link)**



**Figure 8.4-5 CVO Local -> FMS (Reverse Link)**



**Figure 8.4-6 ISP -> Private Vehicle (Forward Link)**



**Figure 8.4-7 Private Vehicle -> ISP (Reverse Link)**

## **9. ITS ARCHITECTURE COMMUNICATION – CONCLUSIONS**

In the last decade, many communication technologies and systems have been introduced at an ever-accelerating pace, and some are gaining wide acceptance. The complex world of telecommunications is evolving and expanding rapidly. For many application areas, including transportation, myriad communication options are available to the system architect and designer. These solutions, of course, meet the requirements at hand with varying degrees of satisfaction, with implications of performance, cost, and user acceptance.

The ITS world is broad and varied, as amply demonstrated by the twenty nine ITS user services with their distinct needs and complex interactions. The National ITS Architecture can be viewed as a framework that ties together the transportation and telecommunication worlds to enable the creation, and effective delivery, of the broad spectrum of ITS services. Throughout the Architecture effort, the emphasis has been on flexibility. This aims to allow the local implementors and service providers to select the specific technologies, within the framework of the architecture, that best meet their needs (expressed either in terms of market realities or jurisdictional constraints).

A basic architectural concept espoused in the definition of the National Architecture is that of a Physical Architecture with a Transportation Layer and a Communication Layer. This concept is specifically intended to mitigate the complexity that arises from the flexibility sought in the ITS Architecture. It enables the separation of the two fairly independent domains of transportation and communication, yet, at the same time, maintaining them tightly coupled to meet the ITS users service requirements. Through this framework, the interconnectivity requirements between the transportation systems can be derived from the ITS user services, and various communication choices can be considered, and objectively evaluated, for their ability to meet those connectivity requirements.

This National ITS Communication Document has presented, under the same cover, the information necessary to describe and characterize all aspects of communications within the National ITS Architecture. The first ingredient provided is a thorough, coherent definition of the “communication layer” of the Architecture.

The Communication Layer (or architecture) for ITS has two components: one wireless and one wireline. All Transportation Layer entities requiring information transfer are supported by one or both of these components. In many cases, the communication layer appears to the ITS user (on the transportation layer) as “communication plumbing”, many details of which can, and should, remain transparent. Nevertheless, the basic telecommunication media types have critical architectural importance. The wireline portion of the network can be manifested in many different ways, most implementation dependent. The wireless portion has three basic and distinct manifestations:

- Wide-area wireless infrastructure, supporting wide-area information transfer (many data flows). For example, the direct use of existing and emerging mobile wireless systems. The wireless interface to this infrastructure is referred to as u1. It denotes a wide area wireless airlink, with one of a set of base stations providing connections to mobile or untethered users. It is typified by the current cellular telephone and data networks or the larger cells of Specialized Mobile Radio for two way communication, as well as paging and broadcast systems. A further subdivision of this interface is possible and is used here in the document: u1t denotes two-way interconnectivity; and u1b denotes one-way, broadcast-type connectivity.
- Short range wireless infrastructure for short-range information transfer (also many data flows, but limited to specific applications). This infrastructure would typically be dedicated to ITS uses. The wireless interface to this infrastructure is referred to as u2, denoting a short-range airlink used for close-proximity (typically less than 50–100 feet) transmissions between a mobile user and a base station, typified by transfers of vehicle identification numbers at toll booths.
- Dedicated wireless system handling high data rate, low probability of error, fairly short range, Advanced Highway Systems related (AHS-related) data flows, such as vehicle to vehicle communication systems. This wireless interface is denoted by u3. Systems in this area are still in the early research phase.

The ITS network reference model was tied to the specific interconnections between the transportation subsystem, e.g., connection between Information Service Provider (ISP) subsystem and a vehicle subsystem (VS) through the Architecture Interconnect Diagram (AID), actually, a whole collection of them of varying levels of detail. The Level-0 AID provided is the top level diagram showing the types of interconnectivities between the various transportation subsystems. It is, perhaps, the best description of the communication framework in the ITS architecture. This AID Level-0 was broken down further to show subsets of it depicting certain interconnectivities of interest, for example, in one case the data flows which use broadcast (u1b), and in another, those that use either broadcast (u1b) or two-way wide area wireless (u1t).

Various media and media types are applicable as possible candidates for each type of interconnection. The best communication technology family applicable to each data flow was specified. This remained above the level of identifying a specific technology or system. In practice, i.e., in a real-world ITS deployment, the final step of selecting a given technology would be performed by the local ITS implementor or service provider. A detailed specification here would have clearly crossed the boundary of architecture definition into the realm of system design.

To assist the implementors and service providers in the ITS community, a broad and balanced technology assessment was performed. It used as much factual information as was publicly available to identify and compare key pertinent attributes of the different communication technologies from a National ITS perspective.

A host of land-mobile (i.e., cellular, SMR, paging, etc.), FM broadcast, satellite, and short range communication systems have been assessed. The assessment addressed the maturity of the candidate technologies and analyzed their capability for supporting ITS in general, and the architecture in particular. Within the limits of reliable, publicly available information, the following attributes were assessed: infrastructure and/or service cost as applicable, terminal cost, coverage, and deployment time-line (if not yet deployed). Furthermore, interface issues (i.e., open versus proprietary) were also addressed from a national ITS perspective. Whenever possible, analysis was performed to determine among other things : 1) supported data rate, 2) delay-throughput, 3) mobility constraints, etc. The ITS Architecture data flow specifications were used in the analysis, including message sizes and update frequencies whenever appropriate. The key comparison characteristics were finally summarized in tables.

Some of the broad conclusions of this assessment are listed below:

A large set of architecture data flows, basically the vast majority of the ult flows, are best supported by commercially available mobile wireless data networks, operated in the packet switching mode. Prominent among these today are CDPD, and private packet radio network systems like RAM and ARDIS. Like the rest of wireless communication, the field is expanding and new candidate systems are joining the arena.

CDPD's technical performance has been validated through ITS-related simulation, as described in Section 8, and through operational field trials (as in the example provided in Appendix J). CDPD is promising because it may provide coverage over the entire footprint of the cellular system in a few years. At the end of 1995, 42% of the population was covered. It is projected that 75% of the population would be covered before the end of 1997. Another version of CDPD, which extends IP capabilities to regular AMPS cellular channels and to the PSTN is called "Circuit Switched CDPD", and will be used to extend CDPD service to areas that do not have the full CDPD overlay implementation on the cellular base stations. Nevertheless, some areas may never have CDPD in any form, and may transition directly to other, more advanced, cellular- or PCS-based packet data systems. (The little information available on those very new systems has been included in the technology assessment sections.)

Service prices for CDPD have gone down to where a mass market can develop, if equipment costs were to drop to the \$200 range, and more applications became available. This will take some time, i.e., a few years, and ITS is no different in this aspect than other wireless data application areas. ITS applications will benefit from the developments, and users acceptance trends, in the broader fields of the mobile office and wireless Internet access.

RAM and ARDIS both have nation-wide coverage that is focused on major metropolitan areas, where there is significant business activity. Since they are basically proprietary systems, it is hard to draw conclusions on their performance (delay/throughput, capacity, and so on). However, anecdotal evidence indicates that they may perform adequately for ITS applications. Non-open systems are generally perceived to be less cost advantageous to the user than open systems. As far as the ITS consumer is concerned, if no cost penalty is perceived, the customer may well choose one of these solutions if the ITS service provider offers the service through them. Issues of coverage outside metropolitan areas, and national inter-operability, may or may not be of concern to the end user. Final decisions on which medium to select will rest with the end users and their constraints, and will be heavily influenced by cost.

Metropolitan area network (MAN) type wireless data systems intended for the non mobile user (only for fixed and pedestrian speeds), such as systems by Metricom and TAL, can be used for ITS information access, or other ITS user services if the user's mode of utilization is not mobile and the application is not time critical. These systems could offer price advantages over mobile

wireless data systems, because of simplicity. Prices of wireless data services will all follow a downward trend. However, individual prices for specific uses are harder to predict than the weather! The economic tradeoffs would obviously have to be performed by the consumer on a case by case basis.

Two way paging (narrow band PCS) systems were also assessed. These can be used to carry ITS services that are not time critical, or that do not require a real time response. Particularly suitable would be messages for which a canned response would suffice. Whether these features would be acceptable or not to an end customer, is a function of the detailed implementation of the ITS application offered by the service provider.

An array of satellite systems was also assessed for supporting the National ITS Architecture. These include a variety of Little (data only) and Big (voice and data) low-earth-orbit (LEO) systems, as well as more conventional medium-earth-orbit (MEO) and geosynchronous (GEO) satellite systems. Most of these systems are not yet deployed but are projected to be in service in a few years. Because of terminal and service cost, satellite systems in general would be used where terrestrial alternatives (e.g., those listed above) are not available. Little LEO choices seem to be the most appropriate for ITS among satellite systems, since they are targeted specifically to short bursty data transactions.

As for one way ITS data flows, those can be carried on one of several Broadcast media. The most prominent among these are FM Subcarrier systems. A detailed quantitative assessment of the three leading high speed subcarrier systems was performed. These are the HSDS, DARC, and STIC systems, which all have roughly 7-8 kbps throughput. The analysis showed that any would be adequate to carry the broadcast data flows envisioned and incorporated into the definition of the architecture. Cost and reliability of the communication service will depend on the details of the infrastructure deployment and the implementation of the service. At this point, those systems are vying for a share of the market and for becoming a national standard. The low speed RBDS FM subcarrier standard can also be used for the ITS data flows if the update rates are maintained low, at about once per ten minutes, again depending on the detailed implementation of the service.

It should be kept in mind that broadcast links, those denoted u1b, do not have to be implemented over FM subcarrier. Many two-way wireless systems, such as two-way paging and CDPD, have broadcast protocols in the forward direction (infrastructure to vehicle), and could, in principle, be used. Also any array of one-way paging services could be used in one form or another. The cost of service and equipment, and the detailed service features, will determine the approach most attractive to customers and ITS service providers.

One of the great advantages of the wide-area wireless, u1, interface defined in the communication layer of the National ITS Architecture, is that it relies on sharing of commercially available wireless infrastructures. Over the next several years, an explosion of such wireless infrastructures and services will be taking place. ITS will stand to benefit enormously from this powerful trend, and must leverage it to the fullest extent.

The second distinct type of infrastructure required in the ITS architecture is for dedicated short range communication (DSRC). This utilizes the so-called beacon systems, which are typically RF transponders mounted in very close proximity to the road infrastructure. Because of their dedicated nature, which implies that all their costs have to be absorbed by the ITS applications they support, as well as their limited range, these systems must be used judiciously. They are adopted in the ITS Architecture only for specific ITS user services whose implementation requires the close physical proximity that wide area wireless systems cannot achieve, either technically or cost-effectively. For example, they are used for toll collection, CVO credentials

checks, parking lot management, and the like. There are some services that could be supported by either the DSRC or wide area wireless, such as fixed-route transit support. For those, the architecture allows for flexibility, and local implementors would need to perform the pertinent cost tradeoffs. For some services, such as vehicle probes, the DSRC, where available for other uses, can be utilized to complement wide area wireless and wired physical sensor systems.

One of the salient conclusions of the Architecture exercise is that short range beacon systems should not be used as a replacement of wide-area wireless systems. In other words, they should not be used to carry such ITS user services as route guidance, mayday, commercial fleet management (dispatch), and so on. The rationale is both technical and economic, and is discussed in the main text and supporting appendices of this document. Basically, beacon systems are not suitable for time critical wide area services, or for those that cannot tolerate interruptions of coverage. However, the cost of widespread urban deployments of such short range systems (e.g., 18,000 beacons to cover 11% of the roads in metro Detroit) would simply be prohibitive and unjustifiable.

There are at present several DSRC technologies, mostly using RF transponders. Some use passive and others active vehicle transponders (tags). In the applications or deployments where one transponder per lane is used, there is no technical basis for selecting one class over the other. In applications where a single beacon is to cover multiple lanes, active vehicle transponders can offer superior performance. There are also beacon systems that operate in the infra-red spectrum; their role is harder to predict at this point. In any event, the ITS architecture should start by accommodating multiple technologies, and gradually transition to the adoption of a single standard that would facilitate the national inter-operability of all the DSRC applications.

From a National ITS Program perspective, the architecture development effort encompassed two broad thrusts: (1) communication architecture definition, i.e., selection of communication service and media types to interconnect the appropriate transportation systems, and (2) several types of inter-related communication analyses, to ensure the feasibility, and soundness, of the architectural decisions made in the definition. The two major communication analysis areas have been:

- An analysis of the data loading requirements derived from the ITS service requirements, the Logical and Physical Architectures and their data flows, the ITS service deployment timeline, and the attributes of the candidate scenarios in the “evaluatory design”.
- An in-depth, quantitative analysis of the real-world performance of selected technologies that are good candidates for adoption as ITS service delivery media, and for which reliable, state-of-the-art simulation tools are available. The performance is determined under the demands of the ITS and other projected applications of the media.

The overall objective of the analyses has been to ascertain whether the National ITS Architecture is feasible from the standpoint that communication technologies exist and will continue to evolve to meet its demands, both technically and cost-effectively. To set the stage for this, data loading analyses were completed for the wide area wireless interfaces u1t, u1b, and the wireline interface w – data loading for the u2 and u3 interfaces is not as useful, so link data rates were determined instead.

The data loading analysis has defined all of the messages that flow between the transportation subsystems. Deployment information from the evolutionary deployment strategy was used to define which services, and therefore which messages would be available for each of the scenario and time frames specified by the Government. The three scenarios provided were addressed,



namely, Urbansville (based on Detroit), Thruville (an inter-urban corridor in NJ/PA), and Mountainville (a rugged rural setting based on Lincoln County, Montana).

Seven user service groups with distinct usage patterns were defined, along with the frequency of use of the messages by each user group. Messages were assigned to the u1t, u1b, and w interfaces based on suitability, and were allowed to flow over multiple interfaces with a fraction assigned to each one. The resulting data loading analyses provided the data loads on all of the above interfaces and links, and a complete description of the message statistics, which were used to drive the communications simulations.

For the u1t interface, the data loading results indicate that for Urbansville in 2002 the largest data loads would result from the CVO-local user service group, followed closely by transit and private vehicles. In Thruville, for the same time period, CVO-local and transit would be the largest data users. For Urbansville in 2012, private vehicle and CVO-local would be the largest data users, at about twice the rate of transit, with the others far below. For Thruville in 2012, CVO-local remains the largest data user, followed by transit. The Mountainville data loads are very low, with CVO-local the largest user, followed by private vehicles.

The ITS Architecture data loading information was used as input to the communication simulations. Due to the relative scarcity of wireless resources (relative to wireline) emphasis was placed on the evaluation of wireless system performance. However, network end-to-end performance, comprising both the wireless and wireline components, given in terms of delay and throughput was also obtained. Furthermore, representative analyses of a wireline networks have also been included.

The wireless simulations performed were for Cellular Digital Packet Data (CDPD), primarily because it is an open standard with a publicly available specification, and because validated, state-of-the-art simulations were made available for use on the ITS Architecture Program. These simulations accurately reflect the mobile system conditions experienced in the real world, including variable propagation conditions, land use/land cover information, user profiles, and interference due to other (voice and data) users. These modeling tools have been tested in the deployment and engineering of commercial wireless networks by GTE.

Simulations have been run for two of the three scenarios provided by the Government only for the 2002 time frame, not only due to the lack of time to analyze all time frames, but because 10 years is the farthest one can accept using present day deployment information. Since the number of users is very small in Mountainville, only cellular coverage was obtained to ascertain its adequacy in that remote area. For both Urbansville and Thruville, scenarios with both ITS and Non-ITS data traffic projected for the CDPD network were run, under normal peak conditions and in the presence of a major incident.

The Government-provided scenario information was substantially augmented with information on actual cellular system deployment obtained directly from FCC filings. A minor amount of radio engineering was performed to fill a few gaps in the information obtained, especially for the Thruville scenario. The commercial wireless deployment assumed in the simulation runs, therefore, was representative of the real operational systems. In fact, because of the continuous and rapid expansion of these systems, the results of the simulations should be viewed as worst case in nature.

The wireless simulation results have shown that the reverse link delay, even in the presence of non-ITS data, and in the case of an incident during the peak period, is very low (150 ms for ITS only; 300 ms for ITS plus non-ITS; with a 10% increase in the cell sectors affected by the incident).

The results of the CDPD simulations have further been validated by the results of an operational field trial that was performed in the spring of 1995, jointly by GTE and Rockwell, in the San Francisco Bay Area. The application demonstrated was commercial fleet management, using GPS location, and CDPD as an operational commercial wireless network. A synopsis of the trial and its results have been presented in Appendix J.

The results for CDPD, summarized above, should be interpreted as a “proof by example”. A commercial wireless data network is available today to meet the projected ITS requirements. Other networks also exist, and can be used, as indicated in the technology assessment sections. Future wireless data networks will be even more capable.

As for broadcast systems, the quantitative analysis has shown that the combination of the low-rate RDBS with the emerging high data rate FM subcarrier standard will satisfy the ITS Architecture broadcast requirements in the foreseeable future. New broadcast techniques, including Digital Audio Broadcasting, which is on the horizon, will accommodate any long term growth.

The simulation results for the wireline network example deployment indicate that extremely small and completely insignificant delays are encountered, when the system is designed to be adequate for the projected use. With the capacities achievable today with fiber, whether leased or owned, wireline performance adequacy is not really an issue. The key issues there pertain to the costs of installation and sustained operation for any given ITS deployment scenario.

The overarching conclusion from the data loading and communication system performance analyses is that commercially available wide area wireless (including broadcast) and wireline infrastructures and services adequately meet the requirements of the ITS architecture in those areas. These systems easily meet the projected ITS data loads into the foreseeable future, and through natural market pull, their continued expansion will meet any future ITS growth. Hence, from that particular standpoint, the National ITS Architecture is indeed sound and feasible.

## TABLE OF CONTENTS

<b>1. INTRODUCTION</b>	<b>1</b>
1.1 Background	1
1.2 Relationship to other Documents	1
1.3 Organization of this Addendum	2
<b>2. HRI PHYSICAL ARCHITECTURE</b>	<b>2</b>
<b>3. COMMUNICATIONS ARCHITECTURE SUPPORT FOR HRI</b>	<b>5</b>
3.1 Approach	5
3.2 HRI-Specific Communications Architecture Elements	6
3.2.1 HRI Data Flow Mapping	6
3.2.2 HRI Architecture Interconnect Diagram	8
<b>4. HRI DATA LOADING ANALYSIS</b>	<b>9</b>
4.1 Approach	9
4.2 Source Data	9
4.3 Assessment	9
<b>5. COMMUNICATION TECHNOLOGIES REVIEW</b>	<b>13</b>
5.1 Wireline Communications	14
5.1.1 Candidate Wireline Technologies	14
5.1.2 Candidate Wireline Topologies	16
5.1.3 Public Network Usage	16
5.1.4 Localized Use of Internet	17

# 1. INTRODUCTION

## 1.1 Background

The initial development of the National Intelligent Transportation System (ITS) Architecture was completed in July 1996. Leading up to this milestone was an intensive 33 month effort consisting of two phases and involving broad participation by public sector, industry, and academic stakeholders. The end-result of this effort was a single national ITS architecture which reflects this broad consensus input. This baseline architecture provides a structure through which the 29 ITS user services identified in the National Program Plan can be delivered throughout the United States. The architecture and analyses presented in the separate Communications Document deliverable were developed to support the original 29 user services.

More recently, a 30<sup>th</sup> user service has been developed that identifies the needs for Highway-Rail Intersections (HRI) under the guidance of the Federal Railroad Administration (FRA) and the US DOT ITS Joint Program Office (JPO). The JPO tasked the two architecture teams, headed by Rockwell International and Lockheed Martin, to modify the national architecture to include this new user service. This addendum provides a review and focused presentation of the elements of the communications architecture and communications analyses which apply to this additional user service.

## 1.2 Relationship to other Documents

This Communications Document addendum is one of a series of reports documenting the National ITS Architecture. In general, sufficient background information has been provided within this addendum so that it may be used without reference to the other reports. The interested reader may refer to these additional reports for more comprehensive treatment of the elements of the overall national architecture documentation that provide a context for this report. Several of the reports that are most pertinent to the subject matter of this document are briefly described in the following paragraphs.

The *Logical Architecture* provides a functional view of all user services, including the HRI user service. It defines the functions that support each user service and all of the information flows that connect these functions. The information flows are source requirements for the communications architecture that is defined in this addendum. The Logical Architecture consists of three volumes that include diagrams that identify all functions and relationships, process specifications that define the functional requirements in detail, and a data dictionary that fully defines all of the information flows.

The *Physical Architecture* collects related logical architecture functions together into subsystems. It defines a set of architecture flows that show all of the data that passes between the subsystems and the special characteristics and constraints associated with each interface. This definition of subsystem connectivity is the basis for the communications architecture.

The *Communications Document* presents a thorough analysis of the communications elements of the National Architecture that support 29 user services. Beginning with the communications requirements associated with the architecture flows, data loading analysis, communications technology surveys, and a detailed simulation of one candidate wireless communications

technology is provided. This addendum extends the communications document by focusing on the impacts to the communication architecture and communication analysis associated with the HRI user service.

### **1.3 Organization of this Addendum**

This addendum consists of five major sections that define the communications architecture that supports the HRI user service and provides selected communications analyses related to this user service.

Following this introduction, section 2 provides a focused presentation of the elements of the physical architecture that support the HRI user service. This is the one place in the National Architecture documentation that provides such a focused treatment of the architecture definition for HRI with some supporting information regarding its derivation.

Section 3 maps the HRI architecture definition to an updated communications architecture. All architecture flows which were defined to support HRI are mapped to this updated communications architecture. Only the elements of the communications architecture that were updated to support HRI are presented. Refer to the Communications Document for a comprehensive treatment of the entire Communications Architecture.

Section 4 provides a qualitative assessment of the data loading requirements imposed by the HRI user service. This assessment is based on the information flows defined in the logical architecture coupled with an evaluatory design and implementation scenario that is consistent with those used as a basis for the companion Cost Analysis Addendum that is published under separate cover.

Section 5 provides a brief review of some of the communications technologies that will support HRI. This section is an excerpt of a more comprehensive technology assessment section that is included in the Communications Document.

## **2. HRI PHYSICAL ARCHITECTURE**

The National ITS Architecture is composed of separate Transportation Layer and Communication Layer domains. The Transportation Layer elements involved in the HRI user service include field equipment at the highway-rail intersection, the management center equipment that operates and monitors the field equipment, and the trains and highway vehicles that are managed by the HRI User Service. The architectural requirements for these transportation elements are documented under separate cover in the Physical Architecture document. The communications layer identifies the general framework for interconnecting the Transportation Layer elements and also includes supporting communications technology and data loading implications for the user services. The communication layer elements for the HRI user service is the focus for this addendum. In order to provide context for the communications discussion, an overview of the overall architecture for HRI is provided in this section.

Figure 1 is a high-level depiction of the transportation elements required for the HRI user service and their general connectivity. It shows equipment and interfaces traditionally operated by the railroads as well as equipment under the jurisdiction of state and local transportation agencies and key interfaces between highway and railroad assets that may be implemented to support HRI improvements. Table 1 expands on the figure by providing a brief overview of each of the interconnections.

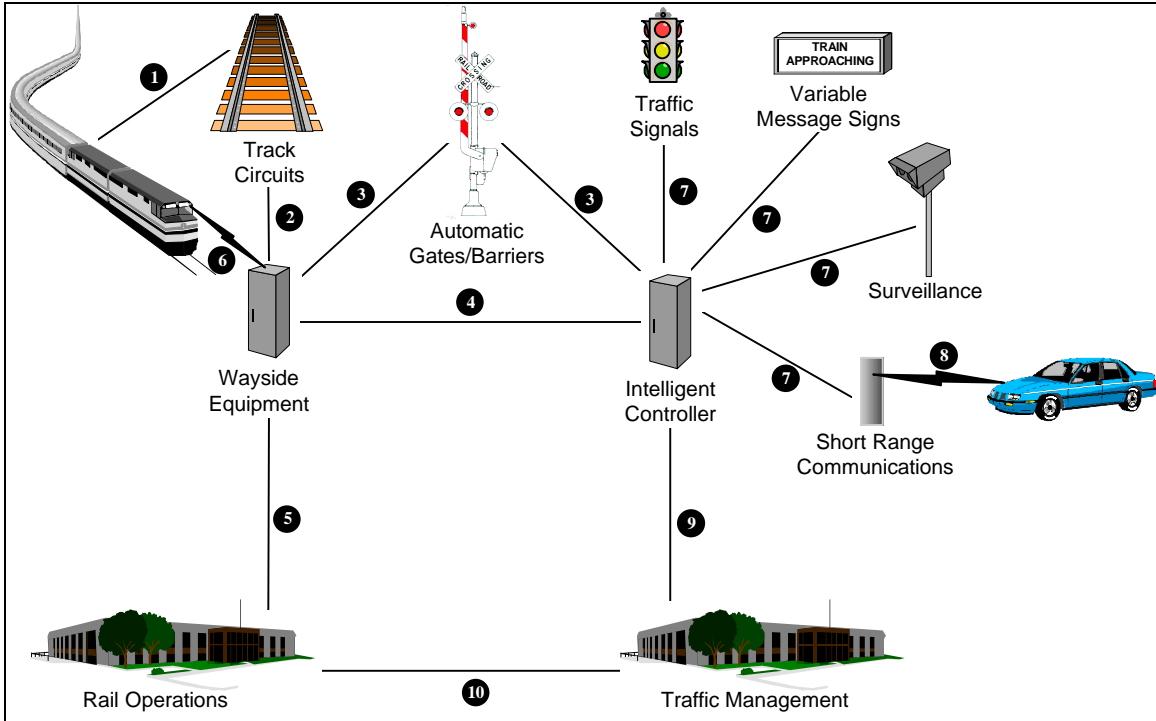


Figure 1: HRI Elements and Interconnects

Table 1: HRI Interconnects Overview

	Type	Purpose	Variations
1	Physical	Detect train presence, speed, acceleration	Track circuits are the most common mechanism; other technologies may also be applied.
2	Wireline Discrete	Fail-safe discrete representation of train activity at the intersection	Characteristics will be a function of the surveillance technology and wayside equipment requirements.
3	Wireline Discrete	Fail-safe discrete activation of signals/gates at the grade crossing	Railroad grade crossing devices are 12 volt systems. Highway-highway intersection devices are 110 volt systems.
4	Wireline Discrete or Data	Communicate train presence from wayside equipment that is aware of train activity to roadside equipment that manages highway traffic. The purpose today is to allow control strategies at adjacent highway-highway intersections to adapt to HRI closures. The same interface could be used to notify roadside equipment to activate signals/gates and other traffic management devices at the grade crossing in other implementations.	Several variations may be implemented in different scenarios and timeframes. Near term implementations pass a discrete signal indicating that the grade crossing is closed (“Interconnect”) or warning that the crossing will be closed in a short time (“Preemption”). This basic connectivity may be expanded to a data interface providing more detailed information on expected closure times, duration, and train activity.

	Type	Purpose	Variations
5	Wireline Data	Monitoring and control of wayside equipment. Represents the railroads wireline network providing connectivity to wireless base stations, switches, signals, gates and other networked railroad assets.	Network characteristics will be different for different railroads.
6	Wireless Data	Communications with the train is an alternative method for monitoring train position/speed and deriving HRI closure requirements. Communications to the train enables early warning of potential intersection hazards.	Communications from the train back to a control center (Rail Operations) prior to HRI activation vs. Short range communications to wayside equipment which locally determines HRI closure requirements.
7	Wireline Discrete or Data	Local monitoring and control of traffic surveillance and traffic control devices enabling monitoring and management of highway traffic in the vicinity of HRI's.	Intelligent devices require data interfaces to support programming and status monitoring. Basic signals require only discrete voltage inputs.
8	Wireless Data	Direct provision of HRI status data to in-vehicle devices. Data may be provided as informational displays to the driver, used to provide safety warnings to the driver, or used as an input to vehicle control systems.	Content and timing requirements for the interface vary with intended in-vehicle application.
9	Wireline Data	Central monitoring and control of highway traffic surveillance and control devices.	Many different protocols currently implemented. Potentially significant future migration to NTCIP as a standard for this interface.
10	Wireline Data	Sharing of HRI status and closure schedules between highway management and rail management systems	Shared data may be limited to as-needed communication of detected equipment failures affecting HRI communications or extended to more regular communication of real-time information enabling HRI closure forecasts.

Figure 2 identifies the mapping between the HRI elements and the Physical Architecture subsystems and interconnects. As can be seen, the physical architecture aggregates roadside surveillance, controller, and device equipment associated with HRI into the roadway subsystem. This approach is consistent with the approach for highway-highway intersection equipment in recognition of the high degree of potential commonality between this equipment. Similarly, the Wayside Equipment terminator encapsulates the wireless interface to the train as well as the other interrelated wayside surveillance and control equipment that are the exclusive domain of the operating railroad/rail agency. This general approach, to refrain from specification of internal railroad requirements within the National ITS Architecture, also resulted in identification of Rail Operations as a terminator. This mapping focuses the National Architecture specifications on those interfaces which span agency and public/private boundaries.

Consistent with the Transportation Layer Definition, the communication layer focus is on the interagency interfaces identified as #4 (Roadway - Wayside Equipment) and #10 (Rail Operations - Traffic Management) as well as the existing National Architecture interfaces that are also necessary to support HRI user service requirements (#8 Roadway - Vehicle and #9 Traffic Management - Roadway).

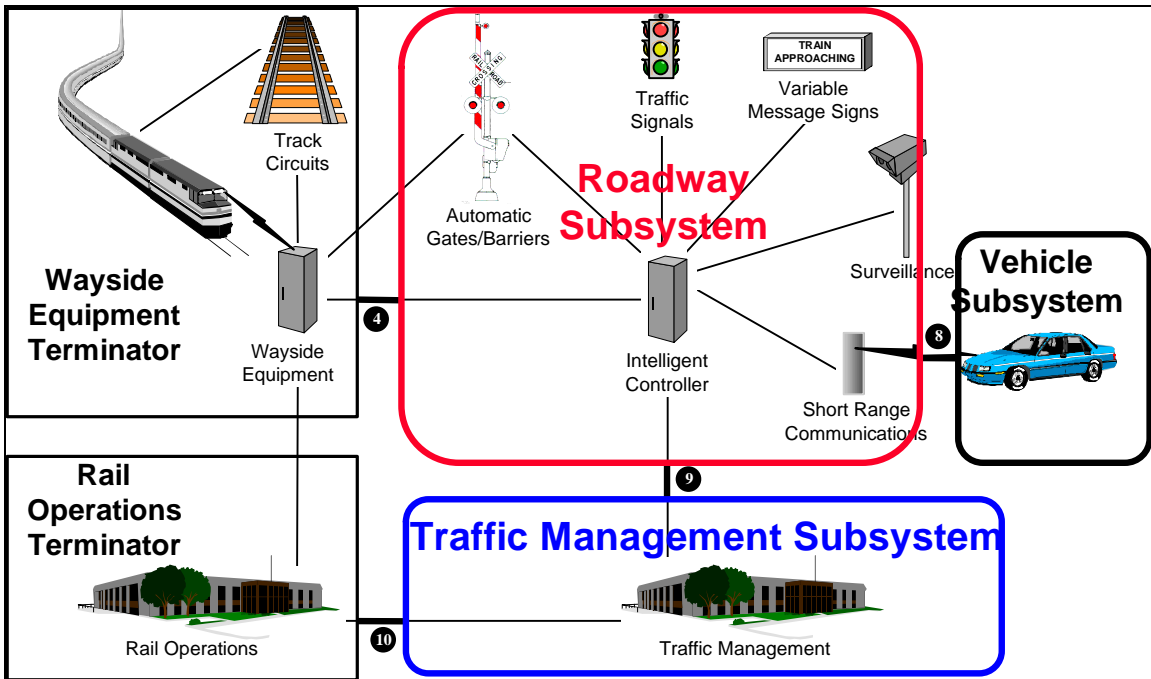


Figure 2: Physical Architecture Mapping

### 3. COMMUNICATIONS ARCHITECTURE SUPPORT FOR HRI

#### 3.1 Approach

The Communications Architecture defined in the Communications Document is in most ways robust enough to address the communication requirement posed by the HRI User Service. The existing architecture was evaluated and refined following the same general approach used for developing the architecture. The figure describing the communications architecture development approach presented in chapter 2 of the Communications Document is reiterated in figure 3 with annotations highlighting the areas in which the HRI user service has impact. These new or changed communications architecture products are presented in this section.

As shown in the figure, the basic Communications Services Hierarchy and Network Reference Model established for the first 29 user services is equally applicable to the HRI user service. The wireline ( $w$ ) and wireless interfaces ( $u1$ ,  $u2$ ) identified in the Network Reference Model support the interagency connectivity and information distribution requirements for HRI. Similarly, the basic interactive and distribution communication services are inclusive and cover all communication service categories applicable to HRI.





**Table 2: New HRI Flow Mapping**

Source	Destination	Architecture Flow	Logical Data Flow	Interconnects	Comm Service
Rail Operations	Traffic Management	railroad advisories	fro_incident_notification	w	c, m
Rail Operations	Traffic Management	railroad schedules	fro_maintenance_schedules	w	c, m
Rail Operations	Traffic Management	railroad schedules	fro_train_schedules	w	c, m
Roadway Subsystem	Traffic Management	hri status	hri_guidance_for_beacon_message	w	c, m
Roadway Subsystem	Traffic Management	hri status	hri_guidance_for_vms	w	c, m
Roadway Subsystem	Traffic Management	hri status	hri_status	w	c, m
Roadway Subsystem	Traffic Management	hri status	hri_traffic_data	w	c, m
Roadway Subsystem	Traffic Management	hri status	rail_operations_message	w	c, m
Roadway Subsystem	Traffic Management	hri status	traffic_management_request	w	c, m
Roadway Subsystem	Traffic Management	intersection blockage notification	hri_blockage	w	m
Roadway Subsystem	Traffic Management	intersection blockage notification	intersection_blocked	w	m
Roadway Subsystem	Wayside Equipment	hri status	twe_hri_status	w	c, m
Roadway Subsystem	Wayside Equipment	intersection blockage notification	twe_stop_highway_indication	w	m
Roadway Subsystem	Wayside Equipment	intersection blockage notification	twe_stop_train_indication	w	m
Traffic Management	Rail Operations	hri advisories	tro_equipment_status	w	c, m
Traffic Management	Rail Operations	hri advisories	tro_event_schedules	w	c, m
Traffic Management	Rail Operations	hri advisories	tro_incident_notification	w	c, m
Traffic Management	Roadway Subsystem	hri control data	indicator_sign_control_data_for_hri	w	m
Traffic Management	Roadway Subsystem	hri control data	rail_operations_advisories	w	m
Traffic Management	Roadway Subsystem	hri control data	rail_operations_device_command	w	m
Traffic Management	Roadway Subsystem	hri request	hri_traffic_surveillance	w	c, m
Traffic Management	Roadway Subsystem	hri request	ro_requests	w	c, m
Traffic Management	Roadway Subsystem	hri request	tms_requests	w	c, m
Wayside Equipment	Roadway Subsystem	arriving train information	fwe_approaching_train_announcement	w	m
Wayside Equipment	Roadway Subsystem	arriving train information	fwe_train_data	w	m
Wayside Equipment	Roadway Subsystem	track status	fwe_wayside_equipment_status	w	m

w: wireline interconnect; m: messaging data service; c: conversational data service;

### 3.2.2 HRI Architecture Interconnect Diagram

Construction of an architecture interconnect diagram that supports HRI entails addition of interconnects supporting the two terminators that were added for HRI. The content of this diagram is equivalent to figure 2 where each of the numerical interface designators (e.g., 4, 8, 9, 10) are replaced with awireline or wireless designators as identified in the previous table.

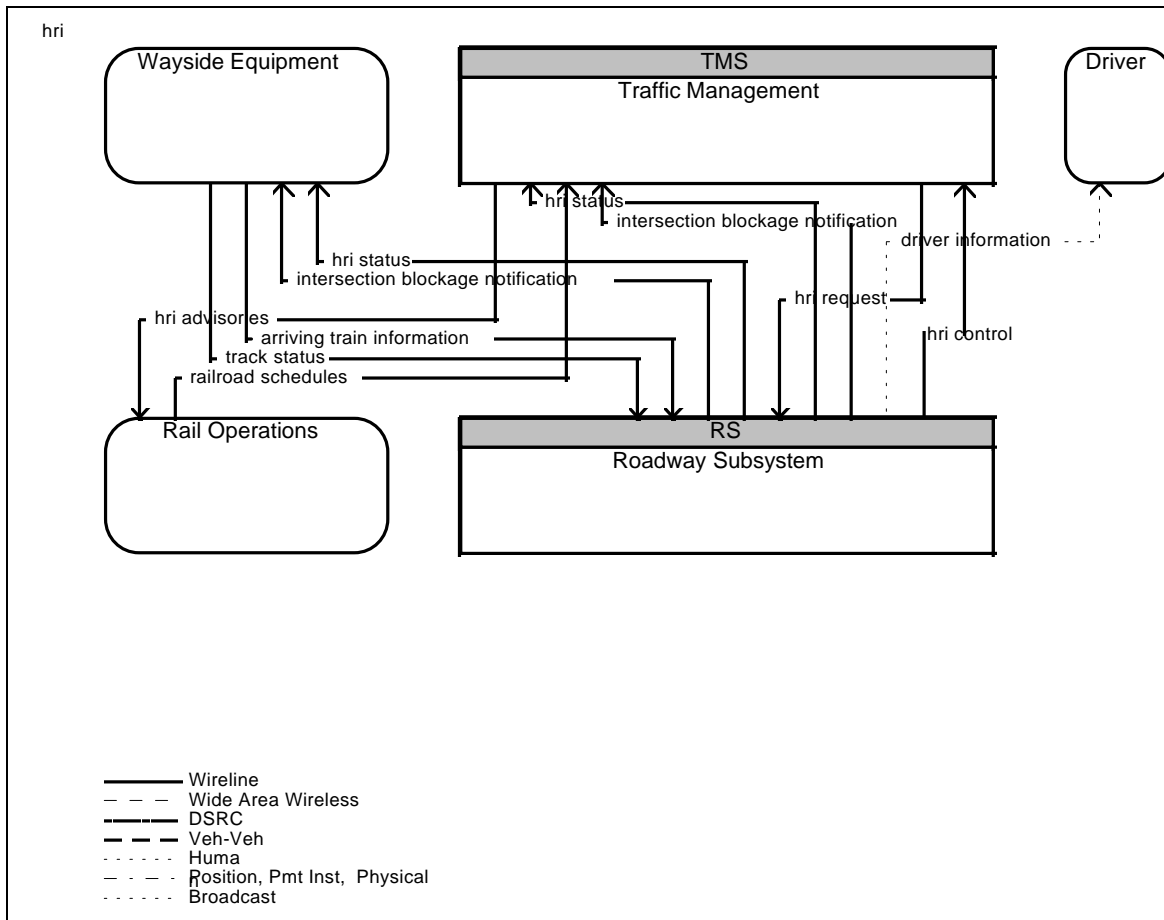


Figure 4: HRI Interconnect Diagram

## 4. HRI DATA LOADING ANALYSIS

### 4.1 Approach

A qualitative assessment of the impacts the HRI user service requirements have on the data loading analysis documented in sections 4 through 6 of this document was performed. This assessment estimates the additional loads on the existing interfaces and the overall loads for the new interfaces that would be required to support the HRI user service. While it is beyond the defined scope of the National Architecture, the likely derived impacts on the wireless interface to the train due to the HRI communications defined in the architecture is also briefly assessed.

### 4.2 Source Data

The new HRI messages in the architecture definition are confined to the wireline interconnects between Rail Operations, the Traffic Management Subsystem, the Roadway Subsystem, and Wayside Equipment. As in the original data loading analysis discussed in sections 4-6 of the Communications Document, the wireline data loading results are derived directly from aggregation of size estimates in the Logical Architecture based on communication user populations consistent with those used in the cost analysis. These user populations and penetration factors for the three time frames and scenarios is depicted in table 3.

Specific size estimates for each logical data flow as extracted from the logical architecture are presented in table 4. The expressions that are used for some of the size estimates in the logical architecture are reconciled for each data flow in the final column of this table. Where the parameter values vary across time frames and scenarios, the values associated with the urban, 20 year scenario were used. As can be seen from the table, none of the messages identified for HRI are anticipated to be very large. The largest HRI-specific message ("railroad schedules") conveys anticipated crossing closure schedules for a particular region.

Table 5 identifies the frequency estimates associated with each of the HRI specific data flows as extracted from the Logical Architecture data dictionary.

The larger messages identified in table 4 are all anticipated to be relatively infrequent messages (i.e., one per day or one per hour) as can be seen from table 5. A range of data loading estimates for various scenarios may be calculated from the input data in tables 3 through 5. The overall data loads associated with the new HRI data flows would be relatively modest for each of the identified scenarios based on the assumptions and estimates identified in these tables.

### 4.3 Assessment

The findings are consistent with that for the other 29 user services; the wireline interfaces can readily accommodate the relatively modest additional loads levied by these future HRI systems. This overall finding must be caveated by the many design assumptions it incorporates. For instance, grade crossing surveillance can be accomplished in many different ways, each with vastly different data loading implications. As in the data loading analysis in the Communications Document, assumptions regarding the number of CCTV cameras, video encoding standards, and desired image quality swamp the other wireline data requirements.

**Table 3: Highway-Rail Intersection Related Scenario Population and Penetration Estimates**

<b>EV Parameters -- Relevant to HRI</b>				<b>Urbansville</b>			<b>Thruville</b>			<b>Mountainville</b>						
<b>Phase II Source Parameters</b>		<b>Basis</b>	<b>5 yr</b>	<b>10 yr</b>	<b>20 yr</b>	<b>5 yr</b>	<b>10 yr</b>	<b>20 yr</b>	<b>5 yr</b>	<b>10 yr</b>	<b>20 yr</b>					
<b>Centers</b>																
	Traffic_Management_Centers	NAR Ev Design	2	3	5	1	1	2	0	0	0					
<b>Roadway Characteristics</b>																
	Std_Speed_HRIs	10% of Intersections; 50% for Rural	256	256	256	104	104	104	10	10	10					
	High_Speed_HRIs	10% of Std_Speed	26	26	26	10	10	10	1	1	1					
	CMS for HRI	40% of SSR + All HSR	128	128	128	52	52	52	5	5	5					
	In-Vehicle Signing Beacons for HRI	25% of SSR + All HSR	90	90	90	36	36	36	4	4	4					
<b>Urbansville Urban-EVD -- Relevant to HRI</b>				<b>Phase II Penetrations</b>						<b>Evaluatory Design Quantities Summary</b>						
<b>Subsystem</b>	<b>EP ID</b>	<b>Equipment Package</b>	<b>Source Parameters</b>	<b>5 yr Low</b>	<b>5 yr High</b>	<b>10 yr Low</b>	<b>10 yr High</b>	<b>20 yr Low</b>	<b>20 yr High</b>	<b>5 yr Low</b>	<b>5 yr High</b>	<b>10 yr Low</b>	<b>10 yr High</b>	<b>20 yr Low</b>	<b>20 yr High</b>	
TMS	TMS18	HRI Traffic Management	TMCs	0%	0%	33%	66%	60%	100%	0	0	1	2	3	5	
TMS	TMS19	Rail Operations Coordination	TMCs	0%	0%	33%	66%	60%	100%	0	0	1	2	3	5	
RS	RS15	Standard Speed Rail Crossing	Std_Speed_HRIs	0%	0%	33%	66%	60%	100%	0	0	84	169	154	256	
RS	RS16	High Speed Rail Crossing	High_Speed_HRIs	0%	0%	33%	66%	60%	100%	0	0	8	17	15	26	
RS	RS7a	Roadway In-Vehicle Signing -- Additional for HRI	In-Vehicle Signing Beacons for HRI	0%	0%	33%	66%	60%	100%	0	0	30	59	54	90	
RS	RS14a	Roadway Traffic Information Dissemination -- Additional for HRI	CMS for HRI	0%	0%	33%	66%	60%	100%	0	0	42	84	77	128	
<b>Thruville InterUrban-EVD -- Relevant to HRI</b>				<b>Phase II Penetrations</b>						<b>Evaluatory Design Quantities Summary</b>						
<b>Subsystem</b>	<b>EP ID</b>	<b>Equipment Package</b>	<b>Source Parameters</b>	<b>5 yr Low</b>	<b>5 yr High</b>	<b>10 yr Low</b>	<b>10 yr High</b>	<b>20 yr Low</b>	<b>20 yr High</b>	<b>5 yr Low</b>	<b>5 yr High</b>	<b>10 yr Low</b>	<b>10 yr High</b>	<b>20 yr Low</b>	<b>20 yr High</b>	
TMS	TMS18	HRI Traffic Management	TMCs	0%	0%	30%	60%	60%	100%	0	0	0	1	1	2	
TMS	TMS19	Rail Operations Coordination	TMCs	0%	0%	30%	60%	60%	100%	0	0	0	1	1	2	
RS	RS15	Standard Speed Rail Crossing	Std_Speed_HRIs	0%	0%	30%	60%	60%	100%	0	0	31	62	62	104	
RS	RS16	High Speed Rail Crossing	High_Speed_HRIs	0%	0%	30%	60%	60%	100%	0	0	3	6	6	10	
RS	RS7a	Roadway In-Vehicle Signing -- Additional for HRI	In-Vehicle Signing Beacons for HRI	0%	0%	30%	60%	60%	100%	0	0	11	22	22	36	
RS	RS14a	Roadway Traffic Information Dissemination -- Additional for HRI	CMS for HRI	0%	0%	30%	60%	60%	100%	0	0	16	31	31	52	
<b>Mountainville Rural-EVD -- Relevant to HRI</b>				<b>Phase II Penetrations</b>						<b>Evaluatory Design Quantities Summary</b>						
<b>Subsystem</b>	<b>EP ID</b>	<b>Equipment Package</b>	<b>Source Parameters</b>	<b>5 yr Low</b>	<b>5 yr High</b>	<b>10 yr Low</b>	<b>10 yr High</b>	<b>20 yr Low</b>	<b>20 yr High</b>	<b>5 yr Low</b>	<b>5 yr High</b>	<b>10 yr Low</b>	<b>10 yr High</b>	<b>20 yr Low</b>	<b>20 yr High</b>	
TMS	TMS18	HRI Traffic Management	TMCs (incl virtual TMC)	0%	0%	0%	0%	0%	0%	0	0	0	0	0	0	
TMS	TMS19	Rail Operations Coordination	TMCs (incl virtual TMC)	0%	0%	0%	0%	0%	0%	0	0	0	0	0	0	
RS	RS15	Standard Speed Rail Crossing	Std_Speed_HRIs	0%	0%	30%	60%	60%	100%	0	0	3	6	6	10	
RS	RS16	High Speed Rail Crossing	High_Speed_HRIs	0%	0%	30%	60%	60%	100%	0	0	0	1	1	1	
RS	RS7a	Roadway In-Vehicle Signing -- Additional for HRI	In-Vehicle Signing Beacons for HRI	0%	0%	30%	60%	60%	100%	0	0	1	2	2	4	
RS	RS14a	Roadway Traffic Information Dissemination -- Additional for HRI	CMS for HRI	0%	0%	30%	60%	60%	100%	0	0	2	3	3	5	

**Table 4: Highway-Rail Intersection Related Data Flow Size Estimates**

Source	Data	Architecture Flow	Logical Data Flow	Size Expressions	Sizes (Bytes)
Rail Operations	Traffic Management	railroad advisories	fro_incident_notification	=1024	1024
Rail Operations	Traffic Management	railroad schedules	fro_train_schedules	=HRI_EVENTS_PER_DAY*(crossing_id+train_id+crossing_close_time+train_arrival_time)	187500
Rail Operations	Traffic Management	railroad schedules	fro_maintenance_schedules	=HRI_MAINT_PER_DAY*(crossing_id+crossing_close_time+crossing_close_duration+1024)	52
Roadway Subsystem	Traffic Management	hri status	hri_guidance_for_beacon_message	=3	3
Roadway Subsystem	Traffic Management	hri status	hri_guidance_for_vms	=3	3
Roadway Subsystem	Traffic Management	hri status	hri_status	=hri_state+hri_closure_data_response	1152
Roadway Subsystem	Traffic Management	hri status	hri_traffic_data	=128	128
Roadway Subsystem	Traffic Management	hri status	rail_operations_message	=128	128
Roadway Subsystem	Traffic Management	hri status	traffic_management_request	=128	128
Roadway Subsystem	Traffic Management	intersection blockage notification	hri_blockage	=16	16
Roadway Subsystem	Traffic Management	intersection blockage notification	intersection_blocked	=16	16
Roadway Subsystem	Wayside Equipment	hri status	twe_hri_status	=1	1
Roadway Subsystem	Wayside Equipment	intersection blockage notification	twe_stop_train_indication	=1	1
Roadway Subsystem	Wayside Equipment	intersection blockage notification	twe_stop_highway_indication	=1	1
Traffic Management	Rail Operations	hri advisories	tro_equipment_status	=128	128
Traffic Management	Rail Operations	hri advisories	tro_incident_notification	=1024	1024
Traffic Management	Rail Operations	hri advisories	tro_event_schedules	=1024	1024
Traffic Management	Roadway Subsystem	hri control data	indicator_sign_control_data_for_hri	=list_size+GRADE_CROSSINGS*(crossing_id+hri_sign_control_data)	701
Traffic Management	Roadway Subsystem	hri control data	rail_operations_advisories	=128	128
Traffic Management	Roadway Subsystem	hri control data	rail_operations_device_command	=128	128
Traffic Management	Roadway Subsystem	hri request	hri_traffic_surveillance	=256	256
Traffic Management	Roadway Subsystem	hri request	ro_requests	=128	128
Traffic Management	Roadway Subsystem	hri request	tms_requests	=128	128
Wayside Equipment	Roadway Subsystem	arriving train information	fwe_train_data	=train_id+train_speed+train_length+train_arrival_time	19
Wayside Equipment	Roadway Subsystem	arriving train information	fwe_approaching_train_announcement	=2	2
Wayside Equipment	Roadway Subsystem	track status	fwe_wayside_equipment_status	=1	1

**Table 5: Highway-Rail Intersection Related Data Flow Frequencies**

Source	Destination	Architecture Flow	Logical Data Flow	Freq. Expression (1 = Once Per Second)	Frequency
Rail Operations	Traffic Management	railroad advisories	fro_incident_notification	1/DAY	1/86400
Rail Operations	Traffic Management	railroad schedules	fro_maintenance_schedules	1/DAY	1/86400
Rail Operations	Traffic Management	railroad schedules	fro_train_schedules	1/DAY	1/86400
Roadway Subsystem	Traffic Management	hri status	hri_status	=ro_requests+tms_requests	1/3600+1/860
Roadway Subsystem	Traffic Management	hri status	hri_traffic_data	=event_notice	188/86400
Roadway Subsystem	Traffic Management	hri status	traffic_management_request	=1/HOUR	1/3600
Roadway Subsystem	Traffic Management	hri status	hri_guidance_for_beacon_message	=hazard_condition	1
Roadway Subsystem	Traffic Management	hri status	hri_guidance_for_vms	=hri_advisory	1
Roadway Subsystem	Traffic Management	hri status	rail_operations_message	=current_hri_state	1
Roadway Subsystem	Traffic Management	intersection blockage	intersection_blocked	=hri_hazard	1
Roadway Subsystem	Traffic Management	intersection blockage	hri_blockage	=current_hri_state	1
Roadway Subsystem	Wayside Equipment	hri status	twe_hri_status	=fwe_approaching_train_announcement	188/86400
Roadway Subsystem	Wayside Equipment	intersection blockage	twe_stop_train_indication	=fwe_approaching_train_announcement	188/86400
Roadway Subsystem	Wayside Equipment	intersection blockage	twe_stop_highway_indication	=fwe_approaching_train_announcement	188/86400
Traffic Management	Rail Operations	hri advisories	tro_event_schedules	=1/DAY	1/86400
Traffic Management	Rail Operations	hri advisories	tro_equipment_status	=1/DAY	1/86400
Traffic Management	Rail Operations	hri advisories	tro_incident_notification	=1/DAY	1/86400
Traffic Management	Roadway Subsystem	hri control data	rail_operations_advisories	=1/DAY	1/86400
Traffic Management	Roadway Subsystem	hri control data	rail_operations_device_command	=1/DAY	1/86400
Traffic Management	Roadway Subsystem	hri control data	indicator_sign_control_data_for_hri	=1	1
Traffic Management	Roadway Subsystem	hri request	hri_traffic_surveillance	=1/HOUR	1/3600
Traffic Management	Roadway Subsystem	hri request	ro_requests	=1/DAY	1/86400
Traffic Management	Roadway Subsystem	hri request	tms_requests	=1/HOUR	1/3600
Wayside Equipment	Roadway Subsystem	arriving train information	fwe_train_data	= DAILY_TRAINS/DAY	188/86400
Wayside Equipment	Roadway Subsystem	arriving train information	fwe_approaching_train_announcement	=DAILY_TRAINS/DAY	188/86400
Wayside Equipment	Roadway Subsystem	track status	fwe_wayside_equipment_status	=1	1

Wireline bandwidth is plentiful, and inexpensive when compared to the wireless communications interfaces. The wireless interface to the train, while not specified by the architecture, may be considered to be the most sensitive to projected data loading increases for advanced HRI implementations which include train notification. For instance, current data communications systems may support only 100 bits per second per train in a worst case scenario. Efficiently managing this bandwidth is a key concern and overall data loading analysis for this interface is an on-going railroad activity as new systems are deployed that require data communications. To support these analyses, the messages that are provided to the wayside equipment that have potential implications for train communications may be considered separately.

An intuitive assessment indicates that HRI communications requirements to the train as identified in the user service are not likely to be a driving factor. Forward channel communications to the train is limited to emergency notification of blockage. By making the simplifying assumption that these warning systems are at every HRI and work perfectly (e.g., false alarm rate = zero), then the number of messages generated per year across the nation would be equal to the number of accidents at grade crossings which was approximately 5000 (excludes light rail) in 1993. While a false alarm rate of zero is an unreasonable expectation, it is unlikely that these systems will be fielded if the false alarm rate is significant due to the expense and risk to the railroad associated with the unscheduled full stops that these false alarms could initiate. At a false alarm rate that will be acceptable to the railroads, the data loading associated with these systems will be nominal. Of course, implementations which provide a positive proceed indication to the train prior to each HRI would incur much higher data loads. Such implementations would also have a higher false alarm rate but would be consistent with fail-safe design practices.

## 5. COMMUNICATION TECHNOLOGIES REVIEW

This section contains a broad review of the various communication technologies that may be used to satisfy the HRI user service communications requirements. The communications technology review is limited to wireline technologies to be consistent with the HRI interfaces identified in the architecture definition. Of course, wireless technologies may also be viable alternatives for communication with widely distributed field equipment at the wayside and roadside. Indeed, most highly distributed system implementations will include both wireline and wireless components in the overall communications solution. This section includes applicable excerpts from the more comprehensive wireline technology survey contained in the Communications Document. Also refer to the Communications Document for wireless technology surveys.

A range of communications technologies will support the interconnects and data flows identified to support the HRI user service. Basic implementations of the Wayside Equipment to Roadway Subsystem interface require only a point-to-point wireline connection providing a discrete voltage that notifies the roadway subsystem of pending HRI activity. More sophisticated network solutions become attractive for the communications between the Roadway Subsystem and Traffic Management Subsystem. Finally, the peer-to-peer communications requirements associated with the Traffic Management Subsystem to Rail Operations interface recommend a third set of communications options.

The intent of this section is solely to provide the reader with a characterization of today's candidate technologies that is as complete as possible, and also to offer a glimpse into the systems that loom on the horizon. Hopefully, this section will provide the implementors with a broad perspective of existing technologies. However, this section does not constitute in any way a technology study for



any particular scenario. In particular, it does not account for any political, institutional, jurisdictional, budgetary or other similar constraints.

## 5.1 Wireline Communications

Wireline network options include the use of private networks, public shared networks, or a mixture of the two. Examples of private network technologies are twisted pair cables, FDDI over fiber optic rings, SONET fiber optic networks, and ATM over SONET networks. Examples of public shared network options are the leasing of telephone company-offered services such as leased analog lines, frame relay, ISDN, metropolitan ethernet, and Internet. A third wireline network option is that of a mixed network, where existing communications infrastructure can be utilized to the greatest extent possible, and possibly upgraded to carry any increased data load. The addition of CCTV in particular can overload the backbone of an existing network.

The decision to specify a private network is probably not motivated by technological reasons because the desired data bandwidth can be supplied through the use of public shared networks. Public shared networks have many other advantages such as cost sharing and risk reduction. It is certain that in the time frames studied that one or more local carriers can provide a network connectivity to fulfill the HRI communications requirements.

The reasons for building a private network have more to do with requirements/preference for a network built to the exact specifications of the user, and with matching the funding mechanism. If one-time capital funding is more easily obtained than monthly lease fees, then a private network appears as the best choice. In any case, there will still be an ongoing maintenance cost.

The active participation of the owners of the roadway right of ways in partnership with one or more commercial carriers may be a means of having a private network built for ~~the~~ infrastructure at little or no cost to the local agency. In exchange for the use of the rights of way, the carriers would provide a portion of the network capacity ~~for~~ use, and much of the maintenance cost. Bartering of railroad right-of-way offers similarly attractive options to the railroad operator.

For the purposes of the communication analysis, the owner of the network is not an issue, nor is the exact technology used on each link an issue. The candidate network technologies studied included those that are standardized (or will be in the time frames of interest) and are available in commercial quantities. The choice of a network technology for a deployed network must be based on the specific details of the infrastructure assets deployed in the specific metropolitan area. Any conclusions drawn in this analysis should not be generalized to every deployment area.

### 5.1.1 Candidate Wireline Technologies

The candidate network technologies discussed below are chosen from standardized network technologies because they consist of components available from multiple vendors. There are no added development costs, they are compatible with public shared networks, and they have been tested in various environmental conditions. The candidate private network technologies studied here include Ethernet, Fiber Distributed Data Interface (FDDI), Synchronous Optical Network (SONET), and Asynchronous Transfer Mode (ATM).

In addition to the network technologies listed above, the use of twisted-pair copper lines for the lowest level in a network is considered as a cost saving means of transmission. This allows the

reuse of existing twisted-pair infrastructure. For new construction, the cost of fiber with optical transceivers is close to the cost of twisted pairs with modems.

Ethernet is a network technology based on a bus, primarily used in local area networks. The data rate is typically 10Mbps, and the transmission media is coaxial cable. Access is controlled by a media access protocol (MAC) incorporating a Carrier Sensing Multiple Access with Collision Detection (CSMA/CD) scheme. The access protocols cannot accommodate networks covering a large area efficiently. To cover a metropolitan area the network must be broken down into many smaller LAN areas, which are then linked together using high-speed links. The CCTV camera load in any reasonable area would probably exceed the data capacity of ethernet, so a separate network would be required to carry the video data.

FDDI is a LAN-based network technology using a fiber optic transmission medium. It can support a data rate of 100Mbps, and a total network cable length of 100 km. Up to 500 stations can be linked on a single network. Although a logical ring network topology is required, FDDI can support both star and ring physical topologies. Access to the ring is controlled by a token-passing scheme: A station must wait for a token before transmitting, each station repeats any frames received downstream to the next station, and if the destination address on a frame matches the station address, it is copied into the station's buffer and a reception indicator is set in the frame status field of the message which continues downstream. The message continues downstream through the network to the originating station which then removes the message from the network. An enhancement to FDDI was standardized as FDDI II, which provides a circuit mode of operation. It allocates time slots of FDDI to synchronous channels. Up to sixteen, 1.14Mbps channels can be allocated, with a Mbps channel remaining for a token channel. Using this standard would allow constant-rate data from CCTV cameras to be transmitted on synchronous channels with the remaining time slots available for the asynchronous (packet) data from intersection controllers and sensors.

SONET is an optical interface standard for networks that allows inter-operability between equipment manufactured by different vendors. It defines the physical interface, optical line rates, frame format, and operations, maintenance, and provisioning overhead protocol. The base rate of transmission is 51.84Mbps, and higher rates are allowed as multiples of the base rate. At the base rate, data are transmitted in frames of 90 by 9 bytes every 125 microseconds. Higher rates are achieved by transmitting a multiple number of these frames every 125 microseconds. The first three "columns" of the 90 by 9 byte frame are reserved for overhead data, and the rest constitute the "payload" of 50.11Mbps. The synchronous structure and byte-interleaved structure of SONET allows easy access to lower-order signals, which allows the use of lower-cost hardware to perform add/drop, cross-connect, and other bandwidth allocation techniques, eliminating the need for back-to-back multiplexing/demultiplexing. The overhead allows remote network monitoring for fault detection, remote provisioning and reconfiguration of circuits, reducing network maintenance costs. SONET networks can be configured as point-to-point or ring networks. For fault redundancy, SONET rings are frequently configured as bi-directional rings with one-half of the network capacity reserved for transmission during a fault. In the case of a cut in the two fibers (one for each direction) between two adjacent nodes on the ring, traffic is rerouted by the nodes on either side of the break, in the direction away from the break, using the reserved excess capacity of the ring.

ATM is a packet-switching technology that routes traffic based on an address contained in the packet. Packets are statistically multiplexed through a store-and-forward network, allowing multiple data streams of various data rates to flow through the network with greater instantaneous link efficiency. The technology uses short, 53-byte fixed-length packets, called cells, allowing the integration of data streams of various rates. The short cell length limits the length of time that

another cell must wait before given access to the link. Cells containing video data can be given a priority over data cells, so that continuous video streams will not be interrupted. The 53-byte cell consists of a 5-byte header and 48 bytes of user data. ATM is connection oriented, and every cell travels through the network over the same path, which is specified during call setup. The cell header then contains only the information the network nodes need to relay the cell from one node to the next through the network. ATM connections exist only as sets of routing tables stored in each switch node, based on the cell header. Each ATM switch along the route rewrites the cell header with address information to be used by the next switch node along the route. Each switch node needs to do very little to route the cell through it, reducing switching delay. ATM can be used on a variety of links, and particularly SONET links for the medium-haul lengths required in a metropolitan-area deployment. The ATM concept, being based on switches routing packets, tends to favor a star configuration with a dedicated line to each user. ATM is still in the development phase, but should be considered as one of the strongest network technology candidates for the deployment time frames being considered.

### 5.1.2 Candidate Wireline Topologies

The network connecting the traffic surveillance and traffic management devices near each highway-rail intersection to the TMS will typically be at least a two-level network, with the first network level connecting the devices and associated intelligent controllers to a hub and the second network level connecting each of the section's hubs to the TMS. An additional network level may be added as a set of concentrators deployed throughout the sections to concentrate data over higher-rate lines to the hub. Concentrators are applied in the network where they can be used to decrease the overall network cost.

The use of star connectivity was studied for both levels of the network. The selection of a ring or star network configuration is largely determined by the link transmission technology selected, such as private FDDI networks, and public leased twisted pairs. Examples of some of the connectivity options and their effect on the total length of links was analyzed. The results of the simulations showed clearly that the delay on any reasonably designed wireline network was completely negligible.

It is expected that a common communications network will be used to support communications requirements associated with both highway-rail intersection management and highway-highway intersection management. Even greater efficiencies associated with shared communications infrastructure may be realized if this same common network is also used to support communications between similarly located wayside equipment.

### 5.1.3 Public Network Usage

The candidate shared public network technologies include leased analog lines, digital leased lines, frame relay, Integrated Services Digital Network (ISDN), metropolitan ethernet, Switched Multimegabit Data Service (SMDS), and Internet.

Portions, or all, of the communications links for the architecture can be provided by shared public network technologies. The public network technologies that can be considered to fill a large subset of communications requirements, and are available in most jurisdictions are detailed in Table 4.

Metropolitan ethernet may be available in some jurisdictions as a service provided by CATV companies. This shared network is currently found in only a few metropolitan areas, but could be

offered in many more in the future as CATV systems are upgraded with fiber-optic technology. This network technology is only applicable to the controller data, and cannot handle the CCTV data load.

Many jurisdictions will already have some form of communications network in place for the centralized control of intersection controllers. The architecture will allow the continued use of these networks if desired, with the lower-level twisted-pair links used for the intersection controller data. The addition of CCTV cameras brings the data rate requirement of the network up so that a high-speed network backbone is required. Concentrators can be placed in the network to multiplex the intersection controller links onto the high-speed backbone network, along with the CCTV data links.

**Table 4: Widely Available Public Network Technologies**

<b>Link Technology</b>	<b>Analog leased lines</b>	<b>Digital leased lines</b>	<b>Frame Relay</b>	<b>ISDN</b>	<b>SMDS</b>
<b>Type of service</b>	Dedicated circuit	Dedicated circuit	Packet switched	Circuit switched and packet	Packet switched
<b>Transmission medium</b>	Standard telephone line	Digital facilities	standard telephone line to four-wire T1 technology	basic rate ISDN - standard telephone lines; primary rate ISDN - four-wire T1 technology	four-wire T1, and fiber optics
<b>Data rate</b>	up to 28.8	2.4 Kbps, 64 Kbps, fractional T1, T1 (1.5 Mbps), T3 (4.5 Mbps), DS3 (45 Mbps)	56 Kbps up to T1	Circuit switched B channel 64Kbps, packet D channel 16 Kbps; basic rate ISDN=2B+D, primary rate ISDN = 23B+D	T1, T3, SONET to 155Mbps
<b>Capabilities</b>	point-to-point and multipoint	point-to-point and multipoint	Suitable for data only.	B channel well suited for CCTV which can be used intermittently, D channel for simultaneous data	Suitable for data only.
<b>Comments</b>	Universally available	High reliability	Fixed monthly charge based on data rate	Cost is usage dependent	Cost is usage dependent
<b>Cost/month (rough estimate, based on undiscounted tariffs )</b>		56 Kbps: \$300/month; T1: \$3.50/month/mile + \$2500/month; DS3: \$45/mile/month+ \$16000/month	56 kbps: \$175/month T1: \$435/month	basic rate ISDN: \$25/month + \$0.57/kilopacket for data and \$0.016/minute for B channel	

#### 5.1.4 Localized Use of Internet

The Internet could also potentially provide data communications, but there are security issues in its use for many of the ITS network applications.

The Internet is a collection of networks using TCP/IP protocol (Transmission Control Protocol--TCP, and the Internet Protocol--IP). Since its introduction by the Inter Networking Working Group

in 1982, it has gained tremendous attention in the network communities. (The average time between new networks connecting to the Internet was ten minutes as early as July, 1993.)

Section 7.5.2.4 investigates the feasibility of using the Internet as a communication network between the Traffic Management Subsystem and other transportation centers. This analysis is applicable to consideration for use of the Internet for the TMS to Rail Operations interface. In general, this analysis supports the intuitive assessment of many Internet users that highly variable communications delays will be experienced. Large variations in reliability (measured by packet loss statistics) were also noted. These measures should not preclude use of the Internet for non-secure communications of data where high performance and reliability are not primary considerations.

## APPENDIX A COMMUNICATION ARCHITECTURE DEVELOPMENT AND DEFINITIONS

This appendix provides the definitions for the pieces comprising the communication architecture. The subsections of this appendix are further described as follows:

Section A. describes the different types of communication services.

Section A.2 provides a definition of the logical communication functions

Section A.3 lists the physical communication entities and allocates to them one or more logical communication functions.

Section A.4 describes the ITS communication network reference model and describes the interfaces between communication physical entities.

Section A.5 further identifies the relationship between the Transportation Layer and Communication Architecture definitions

### A.1 Communication Services Descriptions

The communication services define the exchange of information between two points and are independent of media and application (i.e., ITS user service). In essence, they are a specified set of user-information transfer capabilities provided by the communication architecture to a user in the transportation layer. Figure A.1-1 illustrates the hierarchy of communication services, all of which are detailed in the following sections.

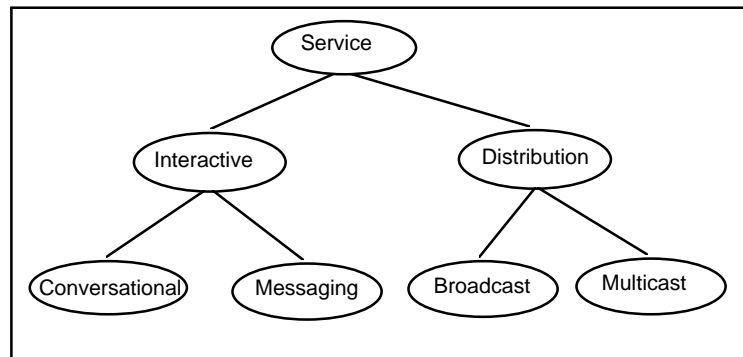


Figure A.1-1 Communication Services Hierarchy

Communication services consist of two broad categories, interactive and distribution. Interactive services allow the user to exchange data with other users or providers in real or near real time, asking for service or information and receiving it in the time it takes to communicate or look up the information. Distribution services allow the user to send the same message to multiple other users. Each of these service categories is further broken down into subcategories, or classes. A brief description of each service class is provided below. Additional information about the interactive service classes and the distribution service classes is given in Sections A.1.1 and A.1.2, respectively.

Interactive services may be either conversational or messaging. Conversational implies the use of a two-way connection established before information exchange begins and terminated when the exchange is completed. Messaging, on the other hand, works more like electronic mail being exchanged between users. The messages are exchanged without establishing a dedicated path between the two sites. Each message is addressed and placed on the network for transmission, intermixed with messages from other users. The communications community labels this mode of communication a “datagram” service.

The distinction between interactive conversational and messaging services needs highlighting to ensure understanding of the choices made later in Table A.1-1. It also must be emphasized that the results shown here represent the iterative steps in the communications architecture design process. During the first iteration, several communication services and information types are considered for a particular data flow. However, after several steps, the initial service choice(s) are re-evaluated and refined to provide the best performance with a particular operation mode. Those service choices are the ones presented in Table A.1-1. The AID diagrams are provided in Section 3 (Level 0) and Appendix B (Level 1).

Conversational services provide the real-time response for a user to initiate a request for service, the request to get to the supporting user host for processing and the response based on that processing being transmitted to and received by the request initiator often within a second or less. An example of this process is the sensing of a Vehicle Subsystem by a Toll Collection Subsystem reading its fare card, sending the data to the Toll Administration Subsystem to verify the account's legitimacy, notifying the Toll Collection Subsystem to accept/deny the fare card, and informing the driver of the Vehicle Subsystem to proceed or to exit the toll road.

Messaging services provide for one-way data transmissions, but also support two way request-response sequences where the response time is more relaxed (typically five or ten seconds, or even more, such as travel planning queries responded to with routing instructions). An analogy is computer E-mail, where a message or file is sent to another user over a computer network and the response may be immediate (when the user is present and gives the response priority over other activities), or later, when higher priority work is completed. This is in contrast to the telephone conversation where an answer is given immediately after receiving the question (effectively last in, first out, at least for questions with easy answers). For Transportation Layer subsystems, the time frame for responses is considerably shorter than in this analogy.

Distribution services may be either *broadcast* or *multicast* and may be used over wireline and/or wireless communication links. Broadcast messages are those sent to all users while multicast messages are sent only to a subset of users. Multicast differs from broadcast in its use of a designated address for all users and user groups. Examples of broadcast information might include current weather or road conditions, whereas multicast information might be information sent to all drivers working for a specific company. A changing group membership could be the set of users traveling between two locations or with a certain destination, for which unique information must be transmitted.

Each of these service categories is oriented to carrying certain types of information. For example, a conversational service can provide voice (pure analog or digitized), data or video at various levels of quality through different types of connections and using different service features. The service characteristics are listed in Tables A.1.1 and A.1.2 under the heading “Bearer Service.”

In addition to the above, each communication service can be connection-oriented or connection-less. The former is analogous to the telephone system, where a link is established (number dialed, the called party answers), the information transfer takes place and the link is terminated (each party hangs up). The connection-less service is analogous to the postal system, where each letter has the full address and is routed from node to node through the system, independently of all the other letters. Unacknowledged connection-less service is often called *datagram service* and is often acceptable when accurate reception is not critical and the extra overhead is not worth the cost. When acknowledged, it is called *acknowledged datagram service*, and is analogous to registered mail.

Additionally in Tables A.1-1 and A.1-2, for each class of interactive service, the tables list the types of information that can be transferred, the service description (e.g., end-end connection, or store/forward) and bearer service. The interactive and distribution services can be offered over wireline links, wireless links, or both.

Note that private lines, readily available from a local Telco or procured by an agency (totally private), support rates from 56/64 kbps to T1 (1.544 Mbps), T2 (6.312 Mbps), T3 (44.736 Mbps), T4M (274.176 Mbps), and SONET OC-N (up to 2.48 Gbps). The various rates listed in Tables A.1-1 and A.1-2 indicate full or partial use of such lines for rates above normal voice-grade twisted-pair rates, which routinely span 300 bps to 14.4 kbps and are now being extended to 28.8 kbps and above with V.32 FAST modems, etc.



### A.1.1 Interactive Services

Two classes of service are identified under this category: conversational and messaging. In both cases, information can be transferred bi-directionally, point-point. The transfer may be transaction-based, unidirectional send/retrieve, or store-and-forward. These are listed in Table A.1-1.

**Table A.1-1 Interactive Services**

Service	Type of Information	Service Description	Bearer Service
Conversational  Description: Real-time (RT), or near real-time, end-end essential to many information transfer applications, usually with an established connection.	Voice	End-End Voice Connection	Mode: Circuit Access: Demand Symmetry: 2-way, RT Rates: 2.4 – 64 kbps
	Data = Text, Audio, Computer bits	End-End Data Connection	Mode: Circuit Access: Demand Symmetry: 2-way, RT Rates: 300 bps – 2.48 Gbps  Mode: Packet (connection-oriented) Access: Demand Symmetry: 2-way, RT Rates: 4.8 kbps – 622 Mbps  Mode: Non-switched Access: Full-period Symmetry: 2-way, real-time Rates: 4.8 kbps – 2.48 Gbps
	Video	End-End Video Connection	Mode: Circuit Access: Demand Symmetry: 2-way, RT Rates: 64 kbps – 155 Mbps
Messaging  Description: User-user information transfers that do not require real-time, dedicated connections.	Voice	Retrieve Send Store/Forward	Mode: Circuit/Packet Access: Demand, Reserved, Random Symmetry: Bi-directional Rates: 2.4 – 64 kbps
	Data = Text, Audio, Image, Computer bits	Retrieve Send Store/Forward	Mode: Packet (connection-less) Access: Demand, Reserved, Random Symmetry: Bi-directional Rates: Low-rate: 4.8 kbps – 64 kbps Hi-rate: 128 kbps – 622 Mbps
	Video	Retrieve Send Store/Forward	Mode: Circuit/Packet Access: Demand, Reserved, Random Symmetry: Bi-directional Rates: 64 kbps – 155 Mbps Slow-scan: <sup>2</sup> 14.4 kbps

### A.1.2 Distribution Services

Distribution Services provide for the unidirectional dissemination of information from point to multipoint, where the multipoint may be all users on the network (broadcast) or a subset of all users on the network identified by a group address (or by multiple individual addresses).

**Table A.1–2 Distribution Services**

Service	Type of Information	Service Description	Bearer Service
<b>Broadcasting</b>  Description: Information is being communicated to all parties within a coverage area or to parties attached to a wireline distribution plant. In some cases, the receiving party can control which of the broadcast information messages to accept.	Voice	Voice message - Prerecorded - Live Narration	Mode: Direct Packet Symmetry: Unidirectional Rates: 2.4 – 64 kbps
	Data = Text, Audio, Image, Computer bits	Data broadcasting	Mode: Broadcast Symmetry: Unidirectional Rates: Low-rate: 4.8 kbps – 64 kbps Hi-rate: 128 kbps – 2.4 Gbps
<b>Multicasting</b>  Description: Information is sent to a specified group of users spread across several zones or within one zone; not all users receive the information because of an addressing scheme.	Voice	Voice message broadcasting - Prerecorded - Live Narration	Mode: Direct Packet Symmetry: Unidirectional Rates: 2.4 – 64 kbps
	Data = Text, Audio, Image, Computer bits	Data broadcasting	Mode: Broadcast Symmetry: Unidirectional Rates: Low-rate: 4.8 kbps – 64 kbps Hi-rate: 128 kbps – 45 Mbps

### A.1.3 Location Services

Location services mean the ability of a service provider to locate the user, or the user to locate himself by using electronic means. (In this discussion, neither looking at a paper map or reporting one’s position using voice after visual observation count as meaningful location services!) Location services entail the performance of processing and/or measurements of signals that are transmitted and received by the user or an infrastructure with which the user interacts.

Location services are key to the provision of a number of ITS user services across many application areas, for example, route guidance, mayday, vehicle probes, and fleet management. They also play a critical role in services that are related to ITS; such as E-911 and mobile yellow pages. In fact, the Cellular Telecommunication Industry Association (CTIA) has recently reached an agreement with the FCC and a number of associations of emergency officials on required service availability and

performance. All commercial mobile wireless service providers will have to support some location determination capability whose accuracy is 125 m root-mean-square within five years. The choice of the locating technique and service mechanism are left open to the wireless provider. This will ensure that keen competition will exist between the various location technology and service offerings, and the most effective approach may become a standard. Quite likely, however, different location services will co-exist and flourish and be adopted by different users depending on their needs.

The location services use a variety of techniques for estimating user location which are described below. The service offerings use one or more of these technical approaches as will be discussed briefly.

#### ***A.1.3.1 Location Determination Techniques***

Location determination may use different attributes of received signals, these are: signal strength, time of arrival in reference to a standard precise clock, and direction of signal arrival. A triangulation-type of computation is performed on multiple signals. The signals that are used for this process are either generated from transmitting towers (or satellites) or from the mobile unit (i.e., subscriber).

- **The signal strength technique:** The attenuation of the signal level (power) as a function of distance from the transmitting unit has been studied extensively. The measured signal level (i.e., power) from a transmitter, when received at several base sites can be used for estimating the distance from the transmitter. The location determination algorithm uses propagation related data and triangulation to estimate the location of the unit. The main problem with this approach is its inherently low reliability and accuracy. This is because the propagation medium is dynamic and cannot be modeled with a high degree of accuracy. (For example, the propagation environment suffers from multipath, shadowing, and scattering, all with a fair degree of randomness.)
- **The time difference of arrival technique:** This technique measures the arrival time of signals from multiple transmitters, relative to a reference standard clock. The time of arrival information is used for estimating the distance from the transmitter(s). The location determination algorithm (e.g., triangulation) uses this information to estimate the position of the unit. This technique is well known and has been used in RADAR applications as well as the Global Positioning System (GPS). Several terrestrial systems which use this general approach also exist. The accuracy of this method is a function of the signal and processing complexity. Complex systems use spread spectrum signals for determining the time delays; some can achieve accuracy on the order of meters. The challenges for this technique involve the accuracy of the reference time and multipath.
- **Angle of arrival technique:** This technique utilizes phased array antenna technology for detecting the angle of arrival of the transmitted signal. In this technique the mobile units transmit the signals and multiple fixed receiver stations detect the angle of arrival. The complexity in this technique relates to the receiving antenna hardware, and the algorithm. One of the big challenges to this method is the effect of multipath, especially in metropolitan areas, which tend to have strong reflectors.

#### ***A.1.3.2 Types of Location Services***

The location determination techniques described above are implemented in several different configurations. These include:

##### **Terrestrial Infrastructure based location services**

In this category the signal attributes of an existing (shared use) wireless infrastructure, such as cellular, or a separate, dedicated infrastructure are used. To provide the service the infrastructure is equipped with required hardware for detecting the features of the desired signals from the subscribers. Such a service

can use angle of arrival, time of arrival, as well as signal strength technique for estimating the location of a mobile unit. For example:

- The cellular infrastructure (i.e., base stations) will be equipped with special hardware for detecting the attributes of mobile cellular calls. The location determination is performed at a management center connected to the base stations, and then the information is forwarded to the end user via wireline or wireless links. The advantage of this service approach would be the lower cost for the subscriber, since the subscriber unit would have minimum hardware complexity. (For the cellular case there would be no to minimum modification of the handsets). However, this service will typically support a class of mobile units that have a cellular voice capability.
- A dedicated or separate infrastructure can be used for triggering and receiving signals from mobile units. Such a service can use any of the above techniques for location estimation. The draw back will be the deployment cost of a new infrastructure, in addition to the service and terminal cost.

#### Space infrastructure based Location Services

Here the most common approach is that of GPS, where the location determination is performed entirely within the mobile unit, basically using time difference of arrival. In this case, a relatively more complex unit compared to the infrastructure based approach would be required, but autonomous operation is achieved. Other services offer hybrid approaches. Service offerings have been proposed where the necessary satellite signal attributes are detected in the subscriber's terminal but not completely processed. In stead, they are reported to a central office for location computation, map matching etc. This will result in a scaled down user unit hardware, but will require a wireless data link between the mobile and the center.

Various other location service offerings will be introduced in the coming years in conjunction with low earth orbiting satellite systems.

#### ***A.1.3.3 Service Deployment Issues***

Each of the above configurations represents a unique approach to obtaining the location of a subscriber, and making it available to the ITS service provider. Each has its own advantages and potential shortcomings. A complete tradeoff takes into account extensive technical field performance results interpreted in the context of the application requirements, technology costs associated with required infrastructure and/or terminal modifications, deployment feasibility, human factors, applicable user base, as well as the service offering mechanism.

## **A.2 Logical Communication Function Definitions**

Based on the objectives of the communication architecture, a list of logical functions to support the ITS system communication requirements was identified. The primary logical communication functions can be confined to the following:

*Wireless Access:* permits a user to access the network/communication resource from a tetherless device (typically in, or needing communication with, a mobile element).

*Wireline Access:* permits a user to access the network/communication resource through a fixed device.

*Switching:* interconnects functional units, transmission channels, or telecommunications circuits for as long as required to convey a signal.

*Routing:* provides for the transparent transfer of data between two transport entities, even if they are dissimilar.

*Registration:* describes a set of procedures for identifying a user to the network resource as being active.

*Authentication:* ensures that the current user is legitimate, friendly, and acceptable to the network.

*Interworking:* supports interaction between dissimilar operation modes and networks, specifically handling the conversion of physical and electrical states and the mapping of protocols.

*Validation/Billing:* associates a user's profile with a valid accounting record to ensure payment for network usage and/or to compile usage statistics.

*Operations Support:* provides management and administration functions for the various Communication Architecture entities.

### **A.3 Network Entity Definitions**

The functional entities that make up the communication architecture were derived from existing and emerging infrastructure specifications and standards (*e.g.*, TIA, ITU, Bellcore, ANSI). These basic building blocks form the foundation of a generic communication system. As with the transportation layer, each functional entity consists of one or more logical functions. The description of each functional entity shows the mapping of that entity to the logical entities it supports.

**User Device**

Access to a network or communication link through wireless or wireline media. The device includes a terminal connected to a transceiver and supports voice, data, and/or video information types.

**User Profile Module**

User-specific information used for registration, authentication, information delivery, mobility management, and billing. This module holds user-specific characteristics such as personal schedule data, credit card data, encryption keys, preferred service mode, etc. (*e.g.*, smart card).

**Switch**

Switching functions for information delivery as well as routing. Two types of switches are considered — circuit-switch and packet-switch<sup>1</sup>. The circuit switch accommodates circuit-mode operation for voice and data information types and connects to wireline networks such as the PSTN and ISDN. One circuit-switch can handover a live connection to another circuit-switch.

The packet switch accommodates packet mode operation for data information types and connects to wireline networks such as the PDN, ISDN, and Internet. One packet-switch can handover a live connection to another packet-switch.

For interworking between two different switch types, refer to the Interworking Function.

**Wireless Controller**

The Wireless Controller (WC) provides an interface between multiple wireless devices and the switches. The WC allocates wireless facilities and coordinates network facilities. To meet the objective of uninterrupted coverage in the cell-based system, the controller performs handover (handoff) between wireless base stations served by the same controller. The Wireless Controller can also be viewed as the back-end for a suite of short-range beacons.

**Wireless Base Station**

The Wireless Base Station provides access for information delivery to and from tetherless users. The Wireless Base Station handles radio frequency exchanges and converts the information coming over the radio link into baseband for the subsequent system components. The air interface may be realized in many combinations of physical interfaces, link layers, and multiple access techniques.

**Interworking Function**

The Interworking function provides transmission, including routing, between dissimilar networks, especially for inter-mode communication (*e.g.*, circuit-to-packet, packet-to-circuit). This function can be viewed as an adjunct "black-box" capable of performing functions beyond the domain of the switch or interconnected network. It is loosely defined, and can be configured according to the specifications of the network service provider.

---

<sup>1</sup>Although Asynchronous Transfer Mode (ATM) utilizes cell-switching, it is no more than a fast-packet-switch algorithm, and therefore classified as packet-switching.

Registration, mobility management, authentication, validation are supported in the signaling plane rather than by the transport network. The defined entities include Personal Registers and Terminal Registers, with the former archiving information related to an individual and the latter storing information associated with a device. This subtle and important distinction satisfies the objective of seamless operation and provides the user with tremendous flexibility. Records are maintained for all information types (*i.e.*, voice, data, video). Note that not all data flows need to have their user profiles tracked, especially for free or highly localized applications. Detailed elaboration of the public databases is beyond the scope of this study.

Example Profile Databases include:

- Personal Home Location Register ( $HLR_p$ ): stores user identity and contains user information (*e.g.*, current user location, current device, service profile).
- Terminal Home Location Register ( $HLR_t$ ): stores device identity and contains device information (*e.g.*, current station location, device capabilities, device identity for authentication).
- Personal Visitor Location Register ( $VLR_p$ ): stores information regarding a user that is now associated with a device being served by a "visiting" network. Information associated with this user is retrieved from the  $HLR_p$ .
- Terminal Visitor Location Register ( $VLR_t$ ): stores information regarding a device that is being served by a "visiting" network. Information associated with this user is retrieved from the  $HLR_t$ .
- Authentication Center (AC): manages encryption keys associated with an individual user or user device and verifies the legitimacy of the user.

## Wireline Network

The wireline network provides access for information delivery as well as inter-entity (except wireless) connectivity. Wireline network resources handle information transfer between the switch and the fixed user device or among user devices. Although the wireline network is a cloud or collection of multiple nodes, each cloud will be viewed as one virtual node.

Example Wireline Networks include:

- Public-Switched Telephone Network (PSTN): is the ubiquitous telephone network, operating in circuit-mode. A variety of switching technologies, physical interfaces media, and link layer services contribute to a wide range of implementation choices. Basically, there is something for everyone.
- Integrated Services Digital Network (ISDN): offers interactive voice and data services, operating in both circuit and packet mode. The choice of ISDN interface (BRI or PRI) determines the available data rate.
- Internet: provides users with a connection-less datagram carriage protocol accommodating interactive as well as distribution services. It has witnessed explosive growth during the past year. Access is becoming near-ubiquitous. To accommodate growth, OSI is introducing a new routing protocol, CLNP (Connection-less Network Protocol), which supports a 256-bit address field versus the 32-bit address field used in IP.
- Packet Data Network (PDN): provides users with traditional interactive packet services, typically virtual circuit carriage (*e.g.*, X.25 networks, Frame Relay networks).
- Local Networks (LAN, MAN, WAN): provide both switched and non-switched interactive and distribution services among data communicating devices within a local, metropolitan, and wide area. Typically, switching becomes necessary for the WAN case (*i.e.*, interconnecting two or more MANs).



## A.4 Network Reference Model

As discussed previously, the communication architecture design process consists of several steps. The previous sections presented the communication logical functions and the communication physical entities. The architecture design process proceeds here with the development of the Communication Network Reference Model. This model provides an architecture or structure that shows how various communication technologies can implement the Architecture Interconnect Diagrams (Level 0 AIDs in Section 3; Level 1 AIDs in Appendix B).

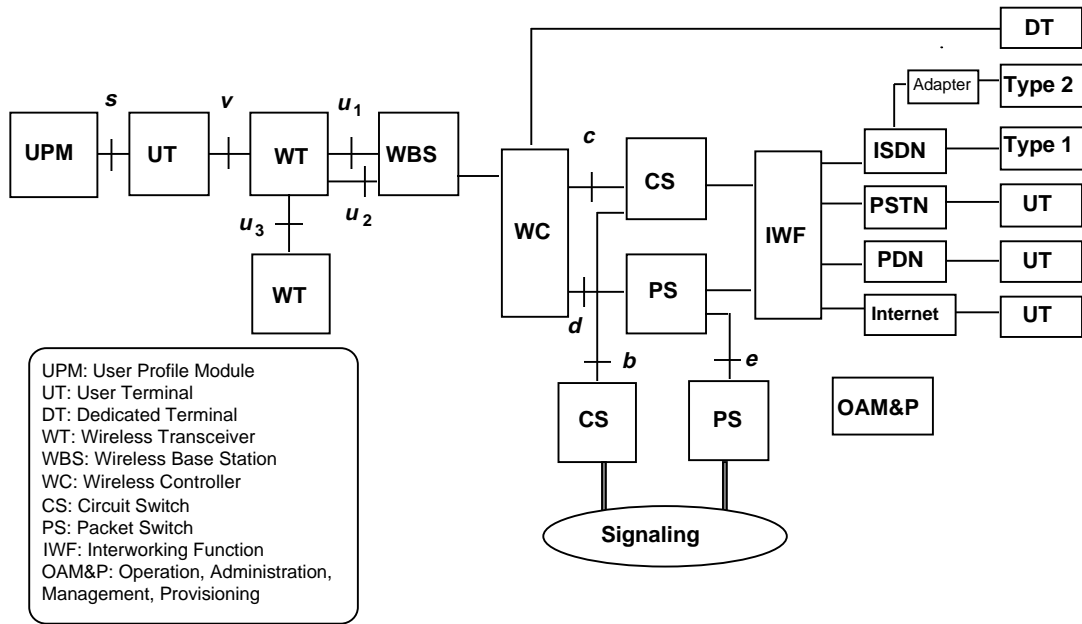
The network reference model shown in Figure A.4-1 is a generic abstraction representative of several reference models developed for standard commercial systems including Personal Communications Services (PCS) architectures, Groupe Speciale Mobile (GSM) or DCS-1800, TIA-IS-41, Cellular Digital Packet Data (CDPD), Intelligent Network (IN) architectures, etc. Boxes represent the various physical equipment (with descriptive uppercase letters) that perform the communication functions. Identified by lowercase letters ( $s$ ,  $v$ ,  $u_1$ ,  $u_2$ ,  $u_3$ ), the interfaces important to ITS are described in the following paragraphs.

Since the wireline segment encompasses standard wireline configurations, the ITS-critical elements from a standards perspective are those comprising the wireless portion on the left side of Figure A.4-1. The wireless portion consists of the User Profile Module (UPM), the User Terminal (UT), the Wireless Transceiver (WT) and the Wireless Base Station (WBS). The connections through the Dedicated Terminal and various User Terminals are shown in the column of boxes on the right. The equipment in the center is the existing public telecommunications services, so the details are transparent to ITS, which is a major benefit to the ITS community. *All management, operations, expansion, and improvement costs are shared with the wider set of all telecommunications users.*

This is a very important point to jurisdictions and agencies who prefer to procure and trench their own network along the right-of-way. Whereas a financial sensitivity analysis may point to a private solution, it frequently does not consider the enormous Operation, Administration, Management, and Provisioning (OAM&P) fees that the agency will have to pay the telecommunications vendor during the system's life cycle.

The most important reference point is the wireless interface ( $u$ ) connecting the WBS and the wireless transceiver. To meet most of the communication element's objectives, as well as those of the overall architecture, it is imperative that the air interface become standard. The wireless portion of the architecture is manifested in 3 different ways, all of which demand a nationally-acceptable air link. Therefore, the  $u$  interface is realized in three ways:  $u_1$ ,  $u_2$ ,  $u_3$ , with each interface corresponding to one of the wireless manifestations, as defined:

- $u_1$  defines the wide-area airlink to one of a set of base stations providing connections between mobile users or mobile and PSTN-connected users. It is typified by the current cellular telephone networks or the larger cells of Specialized Mobile Radio, etc., for two-way communication, and FM subcarrier or paging networks for one-way communication;
- $u_2$  defines the short-range airlink used for close-proximity (typically, less than 50–100 feet) transmissions between a mobile user and a base station, typified by transfers of vehicle identification numbers at toll booths; and
- $u_3$  addresses the vehicle-vehicle (AHS-type) airlink, for high data rate, burst, usually line-of-sight transmission with high reliability between vehicles, where standards are in their infancy.



**Figure A.4-1 Network Reference Model for the Communications Architecture**

On the wireline side, user devices attach through the PSTN, ISDN, Internet, or PDN, operating in circuit or packet mode. The dedicated terminal accesses non-switched, dedicated infrastructures (e.g., a direct connect to a base station's wireless controller). An Interworking Function (IWF) mediates between two different operational modes. As will become evident in later sections, the IWF assumes more than one composition. In some implementations, there may be no IWF between the switched and the wireless networks. OAM&P (Operations, Administration, Management, and Provisioning) systems interface to virtually all functional entities except user devices.

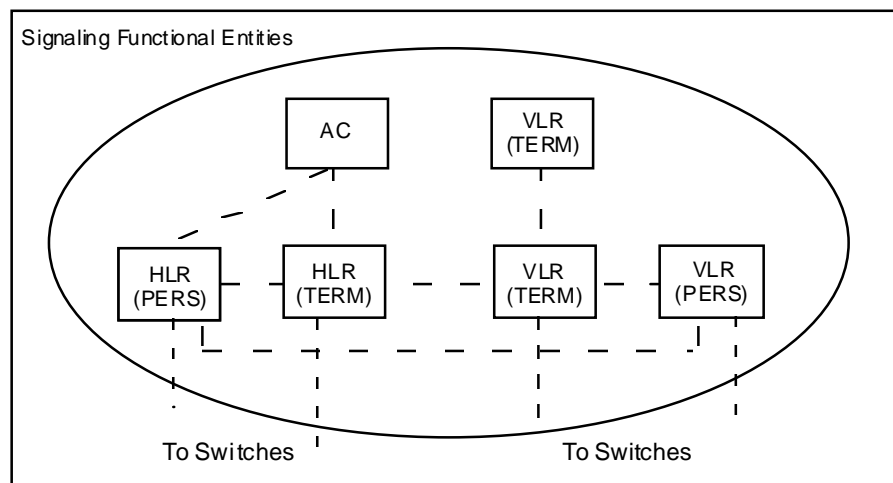
The switches appearing in this model are the functional communication entities mediating wireless traffic. It is likely that the circuit switch handles both voice and data information types whereas the packet switch handles data exclusively. The *b* and *e* interfaces are points of connectivity between switches of the same kind, and noted as reference points because neighboring switches must be able to communicate with each other to handover live connections, regardless of information type. Although both *b* and *e* interfaces should be considered for standardization, they are beyond the purview of the ITS community.

The interfaces between the switches and the wireless controller (WC) can be considered for standardization, if only to maintain a network open to all vendors (*i.e.*, a network operator does not have to purchase a switch, WC, and WBS from the same vendor). The *c* and *d* interfaces may be standardized by the telecom community.

The wireless transceiver is actually the RF front-end to a user terminal. The terminal contains the protocol control logic to establish and tear-down connections and to process packets. Given the objective of integrating maximum functionality into a single device, the user terminal may have the capability to handle both voice and data information types (slow-scan video or compressed video, such as MPEG files, are considered as data types rather than video types). Identity information (either personal or terminal) is described by the User Profile Module, which may be hardwired into the terminal or portable (*e.g.*, a smartcard). The team favors the portable approach to the UPM, but does not preclude terminals with hardwired UPMs. The UPM-terminal interface, noted as the *s* interface, should be standardized to

maintain an open and flexible system. A traveler renting a vehicle in a foreign city should be able to use a UPM to activate a terminal in the vehicle. For the short-range information transfer scenario, the terminal may be a dock for a UPM that stores payment information.

As shown in Figure A.4-2 entities and interfaces comprise the signaling plane, that part of the network which controls user access and sets up circuit connections or addresses packets for transmission along the available route. The user equipment must provide certain information to the signaling functional entities to operate. The entities of importance to the ITS system are the Home Location Register (HLR), the Visitor Location Register (VLR), in both cases for the user as either a person or a terminal, and the Authentication Center (AC), the entity which may manage the encrypting keys associated with an individual user, if such functions are provided for within the network. A detailed description of these interfaces is beyond the scope of the study because most of these entities have been deployed and specified in existing/emerging standards documents. Access to the signaling plane is accomplished by a TCAP Application Protocol delivered over SS7 MTP or X.25 links from circuit and packet switches. ISDN also requires access to the signaling plane for control data. For more details on this component, refer to ANSI Intelligent Networks architectures and TIA IS-41.



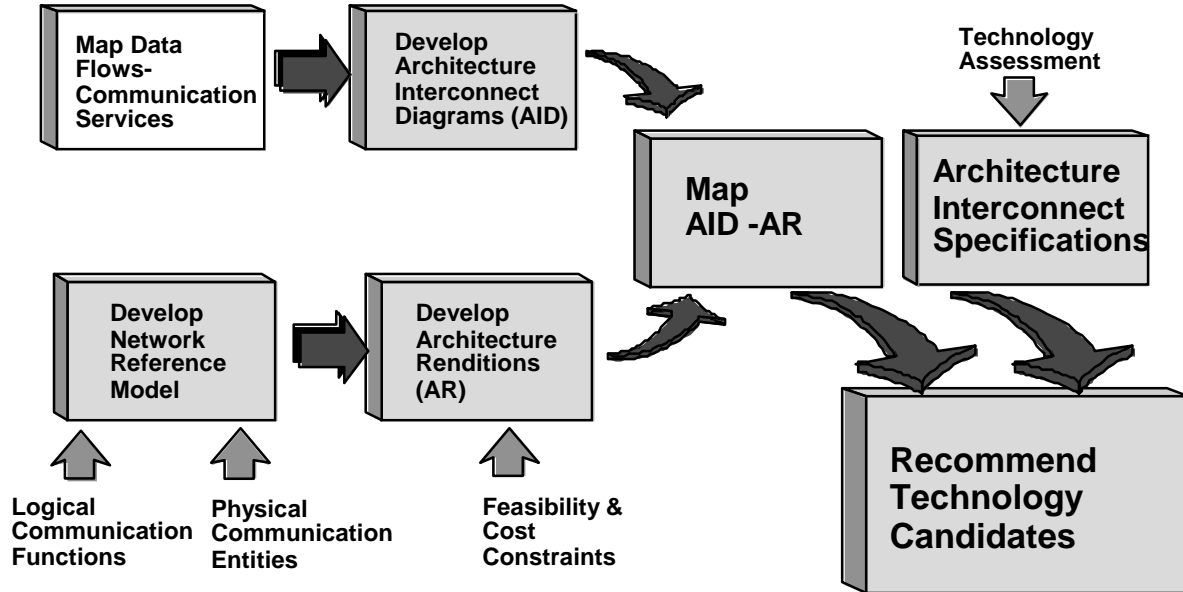
**Figure A.4-2 Signaling Plane Entities**

## A.5 Communication Architecture Linkage

This section further identifies the relationship between the Transportation Layer and Communication Architecture definitions. This is accomplished by mapping the communication services to the data flows identified in the Transportation Layer, generating the Architecture Interconnect Diagrams (AIDs), identifying the Architecture Renditions (ARs), mapping the AIDs to the ARs, identifying the Architecture Interconnect Specifications (AISs) (based on the technology assessment) which completes the definition of the communication architecture.

### A.5.1 Mapping Communication Services to Data Flows

The figure that was provided earlier illustrating the Communications Architecture Design Process is shown again in Figure A.5-1 with the Map Data Flows-Communications block highlighted to guide the reader to the next step in the communication architecture design process.



**Figure A.5-1 Communications Architecture Development Process – Mapping Data Flows to Communication Services**

Table A.5-1 illustrates the mapping between data flows derived from the logical architecture and communication services presented in Section A.1. Mapping of the communication services to the data flows establishes the first link between the transportation layer and the communication architecture, and this initial link depends on the completion of two technical architecture milestones. First, the message sizes and data requirements are to be carried over from Section 6, Data Loading Analysis. Second, the physical architecture that allocates logical functions (see Logical Architecture Document) to subsystems necessitates a partitioning exercise, which defines the data flows that require communication. This mapping is an iterative procedure, calibrated by feedback from the logical and physical architectures (and in turn the ITS stakeholders) by retracing the steps shown in Figure A.5-1.

The mapping process facilitates the synthesis of a preliminary physical communication architecture for several reasons. First, it translates the needs of the data flows, which are traced to the needs of the user services, identified in the transportation layer, to the communication architecture. The mapping shows that some data flows can be accommodated by both wireless links as well as wireline links. Going a step further, the mapping also illustrates communication services that can support the data flow. For example, the *Fleet\_To\_Driver\_Update* flow requires a Messaging service over a packet data network. More than one service are offered for several data flows to maintain maximum flexibility in designing the communication architecture, which accommodates alternative implementations.

The second reason is that the mapping process serves as the baseline for developing an application set protocol. The application protocol provides ITS users with a standardized ubiquitous message set that can be encapsulated with any lower level protocol suite. For example, the message set can sit on top of an IP, X.25, or Frame Relay stack.

Third, this mapping process serves, in some respects, as a validation between the physical and logical architectures, as well as the data loading analysis.

The column names provided in the Table A.5-1 are described below:

**Source & Destination interfaces:** Entries in these columns identify the paired transportation subsystems (e.g., CVAS, FMS, External) which are identified to exchange the designated information or data flow (i.e., the paired transportation subsystems are the end points of the communication link that carries the data flow). The first entry (e.g., CVAS or Commercial Vehicle Administration Subsystem) corresponds to the originating, or source, entity, and the second to the destination, or sink (e.g., FMS or Freight and Fleet Management Subsystem). The transportation subsystem interface entries are derived from the transportation layer physical architecture. Acronyms for the subsystem names are used in the table and are defined below for the reader's convenience.

CVAS	Commercial Vehicle Administration Subsystem
CVCS	Commercial Vehicle Check Subsystem
CVS	Commercial Vehicle Subsystem
VS	Vehicle Subsystem
EMMS	Emissions Management Subsystem
EM	Emergency Management Subsystem
EVS	Emergency Vehicle Subsystem
FMS	Freight and Fleet Management Subsystem
ISP	Information Service Provider Subsystem
PIAS	Personal Information Access Subsystem
PMS	Parking Management Subsystem
RS	Roadside Subsystem
RTS	Remote Traveler Support Subsystem
TAS	Toll Administration Subsystem
TCS	Toll Collection Subsystem
TMS	Traffic Management Subsystem
TRMS	Transit Management Subsystem
TRVS	Transit Vehicle Subsystem
PS	Planning Subsystem

**Architecture Flow:** Entries in this column identify the actual data flows that are transferred between the two transportation subsystems specified in the preceding column. The allocation of the data flows to specific paired subsystem interfaces was derived from the transportation physical architecture. However, the composition of the data flows was obtained from the logical architecture.

**Communication Service:** Entries in this column correspond to the communication services described in Section A.1. Mapping the communication services to the data flows links the transportation layer and the communication architecture; the link transforms two de-coupled, and seemingly independent frameworks into a unified architecture. Selection of communication service entries is based on the data flows definition presented in the Transportation Layer section of the *Physical Architecture* document, which provides insight into the requirements of the data flow. Thus the Data Dictionary indicates the *transit\_information\_requests* message between Information Service Provider Subsystem and the Transit Management Subsystem is a short message. Together with the fixed location of each entity, the shortness leads to the determination that the message can be carried over the existing wired communication services, either on a switched or non-switched basis, depending on the total traffic load for the individual locations. The operation mode can be either circuit, where a pair of wires is set aside for the use of that message, or packet, where the message is divided up into short blocks and each block is individually sent from switch to switch on a path from the source to the destination. At the destination the packets are reassembled into the message and provided to the user. The final choice between circuit and packet is the cost, first between existing plant and new, but then at the technology level, the cost of wires (or

transmitter / receivers, modems) and the cost of computing (dividing up messages or data blocks into packets and reassembling them). With the dropping price of computers and the constant or increasing cost of cable plant, the direction of current technology is toward packet switching.

**Rationale & Critical Attributes:** When necessary for clarification, this column provides justification for the choices in the preceding column, communication service. Most choices reflect quantitative refinement from the operational requirements and the data loading analysis. Note that conversational data may reflect the desire to provide early implementation or implementation in rural areas where user density may not support a more advanced technology in the near to mid term future. Conversational speech capability is noted for those message types which today may be conveyed by voice.

**Note**

Table A.5-1 includes voice services in order to accommodate existing and legacy systems. However, this document focuses on data services since they are envisioned to be the more efficient modes of communication and would be adopted by future systems.

**Table A.5-1 Data Flow – Communications Service Mapping**

W = Wireline  
U1t = Wireless wide area interface

U1b = Wireless wide area one-way broadcast  
U2 = Short range (close proximity) vehicle to roadside wireless interface

Flow #	Source	Source Name	Architecture Flow	Destination	Destination Name	Interconnects	Communication Service	Rationale
1	CVAS	Commercial Vehicle Administration	credentials information	CVCS	Commercial Vehicle Check	W,U1t	Conversational data, messaging data	The CVAS could be a transportable entity. Some transactions may need real time support
2	CVAS	Commercial Vehicle Administration	safety information	CVCS	Commercial Vehicle Check	W,U1t	Conversational data, messaging data	
3	CVAS	Commercial Vehicle Administration	CVO database update	CVCS	Commercial Vehicle Check	W	Conversational data, messaging data	
4	CVAS	Commercial Vehicle Administration	international border crossing data	CVCS	Commercial Vehicle Check	W	messaging data	
5	CVAS	Commercial Vehicle Administration	electronic credentials	FMS	Fleet and Freight Management	W,U1t	messaging data	The CVAS could be a transportable entity.
6	CVAS	Commercial Vehicle Administration	compliance review report	FMS	Fleet and Freight Management	W	messaging data	
7	CVAS	Commercial Vehicle Administration	activity reports	FMS	Fleet and Freight Management	W	messaging data	
8	CVAS	Commercial Vehicle Administration	operational data	PS	Planning Subsystem	W	messaging data	
9	CVAS	Commercial Vehicle Administration	payment request	X21	Financial Institution	W	Conversational data, messaging data	
10	CVAS	Commercial Vehicle Administration	tax-credentials-fees request	X22	Government Administrators	W	messaging data	
11	CVAS	Commercial Vehicle Administration	credentials and safety information request	X59	Other CVAS	W	messaging data	
12	CVAS	Commercial Vehicle Administration	CVAS information exchange	X59	Other CVAS	W	messaging data	
13	CVAS	Commercial Vehicle Administration	violation notification	X62	Enforcement Agency	W	messaging data	
14	CVAS	Commercial Vehicle Administration	license request	X64	DMV	W	messaging data	
15	CVAS	Commercial Vehicle Administration	credentials and safety information response	X65	CVO Information Requestor	W	messaging data	
16	CVCS	Commercial Vehicle Check	credentials information request	CVAS	Commercial Vehicle Administration	W	Conversational data, messaging data	
17	CVCS	Commercial Vehicle Check	roadside log update	CVAS	Commercial Vehicle Administration	W	Messaging data	
18	CVCS	Commercial Vehicle Check	citation and accident data	CVAS	Commercial Vehicle Administration	W	Conversational data, messaging data	

**Table A.5-1 Data Flow – Communications Service Mapping (Cont'd)**

W = Wireline  
U1t = Wireless wide area interface

U1b = Wireless wide area one-way broadcast  
U2 = Short range (close proximity) vehicle to roadside wireless interface

Flow #	Source	Source Name	Architecture Flow	Destination	Destination Name	Interconnects	Communication Service	Rationale
19	CVCS	Commercial Vehicle Check	safety information request	CVAS	Commercial Vehicle Administration	W	Conversational data, messaging data	
20	CVCS	Commercial Vehicle Check	international border crossing data update	CVAS	Commercial Vehicle Administration	W	Conversational data, messaging data	
21	CVCS	Commercial Vehicle Check	clearance event record	CVS	Commercial Vehicle Subsystem	U2	Conversational data	Short range communication, for moving vehicles when passing by specific locations at speeds up to 70 mph
22	CVCS	Commercial Vehicle Check	pass/pull-in	CVS	Commercial Vehicle Subsystem	U2	Conversational data	Short range communication, for moving vehicles when passing by specific locations at speeds up to 70 mph
23	CVCS	Commercial Vehicle Check	safety inspection record	CVS	Commercial Vehicle Subsystem	U2	Conversational Data	Short range communication, for moving vehicles when passing by specific locations at speeds up to 70 mph
24	CVCS	Commercial Vehicle Check	screening request	CVS	Commercial Vehicle Subsystem	U2	Conversational data	Short range communication, for moving vehicles when passing by specific locations at speeds up to 70 mph
25	CVCS	Commercial Vehicle Check	lock tag data request	CVS	Commercial Vehicle Subsystem	U2	Conversational Data	
26	CVCS	Commercial Vehicle Check	border clearance request	CVS	Commercial Vehicle Subsystem	U2	Conversational data	Short range communication, for moving vehicles when passing by specific locations at speeds up to 70 mph
27	CVCS	Commercial Vehicle Check	on-board safety request	CVS	Commercial Vehicle Subsystem	U2	Conversational data	Short range communication, for moving vehicles when passing by specific locations at speeds up to 70 mph
28	CVCS	Commercial Vehicle Check	border clearance event record	CVS	Commercial Vehicle Subsystem	U2	Conversational Data	Short range communication, for moving vehicles when passing by specific locations at speeds up to 70 mph
29	CVS	Commercial Vehicle Subsystem	border clearance data	CVCS	Commercial Vehicle Check	U2	Conversational data	Short range communication, for moving vehicles when passing by specific locations at speeds up to 70 mph
30	CVS	Commercial Vehicle	on board safety data	CVCS	Commercial Vehicle	U2	Conversational data	Short range communication,



**Table A.5-1 Data Flow – Communications Service Mapping (Cont'd)**

W = Wireline  
U1t = Wireless wide area interface

U1b = Wireless wide area one-way broadcast  
U2 = Short range (close proximity) vehicle to roadside wireless interface

Flow #	Source	Source Name	Architecture Flow	Destination	Destination Name	Interconnects	Communication Service	Rationale
		Subsystem			Check			for moving vehicles when passing by specific locations at speeds up to 70 mph
31	CVS	Commercial Vehicle Subsystem	screening data	CVCS	Commercial Vehicle Check	U2	Conversational data	Short range communication, for moving vehicles when passing by specific locations at speeds up to 70 mph
32	CVS	Commercial Vehicle Subsystem	lock tag data	CVCS	Commercial Vehicle Check	U2	Conversational Data	
33	CVS	Commercial Vehicle Subsystem	driver and vehicle information	FMS	Fleet and Freight Management	U1t	messaging data, location data	bursty transactions
34	CVS	Commercial Vehicle Subsystem	on board vehicle data	FMS	Fleet and Freight Management	U1t,U2	messaging data	Bursty transactions
35	CVS	Commercial Vehicle Subsystem	processed cargo data	VS	Vehicle	W	messaging data	
36	CVS	Commercial Vehicle Subsystem	lock tag data request	X08	Commercial Vehicle	W	Conversational Data	
37	EM	Emergency Management	emergency dispatch requests	EVS	Emergency Vehicle Subsystem	U1t	Conversational speech, messaging data	Low delay bursty data or conversational speech
38	EM	Emergency Management	assigned route	EVS	Emergency Vehicle Subsystem	U1t	Conversational speech, messaging data	Low delay bursty data or conversational speech
39	EM	Emergency Management	Hazmat information	EVS	Emergency Vehicle Subsystem	U1t	Conversational speech, messaging data	Low delay bursty data or conversational speech
40	EM	Emergency Management	Hazmat information request	FMS	Fleet and Freight Management	W	Conversational data, messaging data	
41	EM	Emergency Management	emergency vehicle route request	ISP	Information Service Provider	W	Conversational speech, messaging data	
42	EM	Emergency Management	incident information	ISP	Information Service Provider	W	Conversational speech, messaging data	
43	EM	Emergency Management	emergency acknowledge	PIAS	Personal Information Access	W,U1t	Conversational data, messaging data	Wide area communication to PDA
44	EM	Emergency Management	operational data	PS	Planning Subsystem	W	Conversational data, messaging data	
45	EM	Emergency Management	emergency acknowledge	RTS	Remote Traveler Support	W,U1t	Conversational speech, messaging data	Wide area wireless communication to transportable units
46	EM	Emergency Management	incident information	TMS	Traffic Management	W	Conversational data, messaging data	
47	EM	Emergency Management	emergency vehicle greenwave request	TMS	Traffic Management	W	Conversational data conversational speech	

**Table A.5-1 Data Flow – Communications Service Mapping (Cont'd)**

W = Wireline  
U1t = Wireless wide area interface

U1b = Wireless wide area one-way broadcast  
U2 = Short range (close proximity) vehicle to roadside wireless interface

Flow #	Source	Source Name	Architecture Flow	Destination	Destination Name	Interconnects	Communication Service	Rationale
48	EM	Emergency Management	incident response status	TMS	Traffic Management	W	Conversational data, messaging data	
49	EM	Emergency Management	transit emergency coordination data	TRMS	Transit Management	W	Conversational data, messaging data	
50	EM	Emergency Management	emergency acknowledge	VS	Vehicle	U1t	Conversational data conversational speech	Low delay bursty data
51	EM	Emergency Management	emergency status	X13	E911 or ETS	W	Conversational data conversational speech	
52	EM	Emergency Management	map update request	X23	Map Update Provider	W	messaging data	
53	EM	Emergency Management	emergency coordination	X30	Other EM	W	Conversational data, messaging data	
54	EMMS	Emissions Management	operational data	PS	Planning Subsystem	W	messaging data	
55	EMMS	Emissions Management	vehicle pollution criteria	RS	Roadway Subsystem	W	messaging data	
56	EMMS	Emissions Management	widearea statistical pollution information	TMS	Traffic Management	W	messaging data	
57	EMMS	Emissions Management	map update request	X23	Map Update Provider	W	messaging data	
58	EVS	Emergency Vehicle Subsystem	emergency vehicle driver status update	EM	Emergency Management	U1t	messaging data	Low delay bursty data or live voice.
59	EVS	Emergency Vehicle Subsystem	emergency vehicle driver inputs	EM	Emergency Management	U1t	Conversational speech, messaging data	Bursty data or live voice. Minimum delay in data communication for forward and reverse link may be required
60	EVS	Emergency Vehicle Subsystem	emergency vehicle dispatch acknowledge	EM	Emergency Management	U1t	Conversational speech, messaging data	Bursty data or live voice. Minimum delay in data communication for forward and reverse link may be required
61	EVS	Emergency Vehicle Subsystem	emergency vehicle preemption request	RS	Roadway Subsystem	U2	Conversational data	Short range bursty data communication while in motion, when passing by specific locations at speeds up to 70 mph
62	FMS	Fleet and Freight Management	tax filing, audit data	CVAS	Commercial Vehicle Administration	w	messaging data	
63	FMS	Fleet and Freight	credential application	CVAS	Commercial Vehicle	W	Conversational data,	

**Table A.5-1 Data Flow – Communications Service Mapping (Cont'd)**

W = Wireline  
U1t = Wireless wide area interface

U1b = Wireless wide area one-way broadcast  
U2 = Short range (close proximity) vehicle to roadside wireless interface

Flow #	Source	Source Name	Architecture Flow	Destination	Destination Name	Interconnects	Communication Service	Rationale
		Management			Administration		messaging data	
64	FMS	Fleet and Freight Management	information request	CVAS	Commercial Vehicle Administration	W	Conversational data, messaging data	
65	FMS	Fleet and Freight Management	fleet to driver update	CVS	Commercial Vehicle Subsystem	U1t	messaging data	Bursty data
66	FMS	Fleet and Freight Management	Hazmat information	EM	Emergency Management	W	Conversational data, messaging data	
67	FMS	Fleet and Freight Management	route request	ISP	Information Service Provider	W	Conversational data, messaging data	
68	FMS	Fleet and Freight Management	intermod CVO coord	X01	Intermodal Freight Shipper	W	messaging data	
69	FMS	Fleet and Freight Management	intermod CVO coord	X60	Intermodal Freight Depot	W	messaging data	
70	ISP	Information Service Provider	emergency vehicle route	EM	Emergency Management	W	Conversational speech, messaging data	
71	ISP	Information Service Provider	incident information request	EM	Emergency Management	W	Conversational speech, messaging data	
72	ISP	Information Service Provider	route plan	FMS	Fleet and Freight Management	W	messaging data	
73	ISP	Information Service Provider	broadcast information	PIAS	Personal Information Access	W,U1b	messaging data, Broadcast data, Multicast	Free services & services that require subscription
74	ISP	Information Service Provider	trip plan	PIAS	Personal Information Access	W,U1t	Conversational data, Messaging data	Bursty data
75	ISP	Information Service Provider	traveler information	PIAS	Personal Information Access	W,U1t	Broadcast data, Multicast data	Bursty data upon request. Bursty or continuous transmission for one-way systems. Free services and services that require subscription.
76	ISP	Information Service Provider	parking lot data request	PMS	Parking Management	W	messaging data	
77	ISP	Information Service Provider	parking reservations request	PMS	Parking Management	W	messaging data	
78	ISP	Information Service Provider	road network use	PS	Planning Subsystem	W	messaging data	
79	ISP	Information Service Provider	traveler information	RTS	Remote Traveler Support	W	Broadcast data, Multicast data	
80	ISP	Information Service Provider	broadcast information	RTS	Remote Traveler Support	U1b	messaging data, Broadcast data,	Free services and services that require subscription

**Table A.5-1 Data Flow – Communications Service Mapping (Cont'd)**

W = Wireline  
U1t = Wireless wide area interface

U1b = Wireless wide area one-way broadcast  
U2 = Short range (close proximity) vehicle to roadside wireless interface

Flow #	Source	Source Name	Architecture Flow	Destination	Destination Name	Interconnects	Communication Service	Rationale
							Multicast	
81	ISP	Information Service Provider	trip plan	RTS	Remote Traveler Support	W	Conversational Data	
82	ISP	Information Service Provider	request for toll schedules	TAS	Toll Administration	W	messaging data	
83	ISP	Information Service Provider	incident notification	TMS	Traffic Management	W	Conversational Data	
84	ISP	Information Service Provider	request for traffic information	TMS	Traffic Management	W	messaging data	
85	ISP	Information Service Provider	logged route plan	TMS	Traffic Management	W	Conversational data, Messaging data	
86	ISP	Information Service Provider	road network use	TMS	Traffic Management	W	messaging data	
87	ISP	Information Service Provider	transit information request	TRMS	Transit Management	W	messaging data	
88	ISP	Information Service Provider	selected routes	TRMS	Transit Management	W	Conversational data, Messaging data	
89	ISP	Information Service Provider	demand responsive transit request	TRMS	Transit Management	W	messaging data	
90	ISP	Information Service Provider	broadcast information	VS	Vehicle	U1b	messaging data, Broadcast data, Multicast	Free services and services that require subscription
91	ISP	Information Service Provider	trip plan	VS	Vehicle	U1t	Conversational data, Messaging data	Bursty data
92	ISP	Information Service Provider	traveler information	VS	Vehicle	U1t, U1b	messaging data, Broadcast data, Multicast	Bursty data
93	ISP	Information Service Provider	intermodal information	X02	Intermodal Transportation Service Provider	W	messaging data	
94	ISP	Information Service Provider	payment request	X21	Financial Institution	W	Conversational data, messaging data	
95	ISP	Information Service Provider	map update request	X23	Map Update Provider	W	messaging data	
96	ISP	Information Service Provider	travel service reservation	X24	Yellow Pages Service Providers	W	messaging data	
97	ISP	Information Service Provider	traffic information	X27	Media	W	messaging data	
98	ISP	Information Service Provider	incident information	X27	Media	W	messaging data	

**Table A.5-1 Data Flow – Communications Service Mapping (Cont'd)**

W = Wireline  
U1t = Wireless wide area interface

U1b = Wireless wide area one-way broadcast  
U2 = Short range (close proximity) vehicle to roadside wireless interface

Flow #	Source	Source Name	Architecture Flow	Destination	Destination Name	Interconnects	Communication Service	Rationale
99	ISP	Information Service Provider	traffic information	X28	Media Operator	W	messaging data, Broadcast data, Multicast	
100	ISP	Information Service Provider	incident information	X28	Media Operator	W	messaging data	
101	ISP	Information Service Provider	ISP coord	X31	Other ISP	W	messaging data	
102	PIAS	Personal Information Access	emergency notification	EM	Emergency Management	U1t	Conversational data, messaging data, location data	Minimum delay in data communication for forward and reverse link maybe required. Location data for emergency response
103	PIAS	Personal Information Access	traveler information request	ISP	Information Service Provider	W,U1t	messaging data	Bursty messages, Wireless to PDA. Location data for value added services.
104	PIAS	Personal Information Access	trip request	ISP	Information Service Provider	W,U1t	Conversational Data, Messaging data	Bursty messages, Wireless to PDA
105	PIAS	Personal Information Access	trip confirmation	ISP	Information Service Provider	W,U1t	Conversational Data, Messaging data	Bursty messages. Wireless to PDA
106	PIAS	Personal Information Access	yellow pages request	ISP	Information Service Provider	W,U1t	Conversational Data, Messaging data	Bursty messages, Wireless to PDA
107	PIAS	Personal Information Access	demand responsive transit request	TRMS	Transit Management	U1t	messaging data	Bursty messages
108	PIAS	Personal Information Access	map update request	X23	Map Update Provider	W,U1t	messaging data	Service on request or services by subscription
109	PMS	Parking Management	parking lot reservation confirmation	ISP	Information Service Provider	W	messaging data	
110	PMS	Parking Management	parking availability	ISP	Information Service Provider	W	messaging data	
111	PMS	Parking Management	operational data	PS	Planning Subsystem	W	messaging data	
112	PMS	Parking Management	demand management price change response	TMS	Traffic Management	W	messaging data	
113	PMS	Parking Management	parking availability	TMS	Traffic Management	W	messaging data	
114	PMS	Parking Management	transit parking coordination	TRMS	Transit Management	W	Messaging data	
115	PMS	Parking Management	request tag data	VS	Vehicle	U2	Conversational data	Data transfer while in motion, when passing the specific locations at speeds up to 70 mph
116	PMS	Parking Management	tag update	VS	Vehicle	U2	Conversational data	Data transfer while in motion,

**Table A.5-1 Data Flow – Communications Service Mapping (Cont'd)**

W = Wireline  
U1t = Wireless wide area interface

U1b = Wireless wide area one-way broadcast  
U2 = Short range (close proximity) vehicle to roadside wireless interface

Flow #	Source	Source Name	Architecture Flow	Destination	Destination Name	Interconnects	Communication Service	Rationale
								when passing the specific locations at speeds up to 70 mph
117	PMS	Parking Management	payment request	X21	Financial Institution	W	Conversational data, messaging data	
118	PMS	Parking Management	parking status	X36	Parking Operator	W	messaging data	
119	PMS	Parking Management	parking availability	X37	Parking Service Provider	W	messaging data	
120	PMS	Parking Management	violation notification	X62	Enforcement Agency	W	messaging data	
121	PMS	Parking Management	license request	X64	DMV	W	Messaging data	
122	PS	Planning Subsystem	planning data	TMS	Traffic Management	W	messaging data	
123	PS	Planning Subsystem	map update request	X23	Map Update Provider	W	Messaging data	
124	PS	Planning Subsystem	planning data	X25	Transportation Planners	W	messaging data	
125	RS	Roadway Subsystem	pollution data	EMMS	Emissions Management	W	messaging data	
126	RS	Roadway Subsystem	fault reports	TMS	Traffic Management	W	Conversational data, messaging data	
127	RS	Roadway Subsystem	request for right of way	TMS	Traffic Management	W	Conversational Data	
128	RS	Roadway Subsystem	vehicle probe data	TMS	Traffic Management	W	messaging data	
129	RS	Roadway Subsystem	AHS status	TMS	Traffic Management	W	messaging data	
130	RS	Roadway Subsystem	incident data	TMS	Traffic Management	W	messaging data	
131	RS	Roadway Subsystem	freeway control status	TMS	Traffic Management	w	messaging data	
132	RS	Roadway Subsystem	signal control status	TMS	Traffic Management	W	messaging data	
133	RS	Roadway Subsystem	HOV data	TMS	Traffic Management	W	Messaging data	
134	RS	Roadway Subsystem	signal priority request	TMS	Traffic Management	W	messaging data	
135	RS	Roadway Subsystem	local traffic flow	TMS	Traffic Management	W	messaging data	
136	RS	Roadway Subsystem	AHS control data	VS	Vehicle	U2	messaging data	Data transfer while in motion, when passing the specific locations at speeds up to 70 mph
137	RS	Roadway Subsystem	vehicle signage data	VS	Vehicle	U2	messaging data	Data transfer while in motion, when passing the specific locations at speeds up to 70 mph
138	RS	Roadway Subsystem	intersection status	VS	Vehicle	U2	messaging data	Data transfer while in motion, when passing the specific locations at speeds up to 70 mph
139	RS	Roadway Subsystem	request tag data	VS	Vehicle	U2	Messaging data	

**Table A.5-1 Data Flow – Communications Service Mapping (Cont'd)**

W = Wireline  
 U1t = Wireless wide area interface  
 U1b = Wireless wide area one-way broadcast  
 U2 = Short range (close proximity) vehicle to roadside wireless interface

Flow #	Source	Source Name	Architecture Flow	Destination	Destination Name	Interconnects	Communication Service	Rationale
140	RS	Roadway Subsystem	grant right of way and/or stop traffic	X29	Multimodal Crossings	W	Conversational data, messaging data	
141	RTS	Remote Traveler Support	emergency notification	EM	Emergency Management	W,U1t	Conversational speech, messaging data, location data	RTS can be a transportable unit. Location data emergency response.
142	RTS	Remote Traveler Support	yellow pages request	ISP	Information Service Provider	W	Conversational data, Messaging Data	
143	RTS	Remote Traveler Support	trip request	ISP	Information Service Provider	W	Conversational Data	
144	RTS	Remote Traveler Support	traveler information request	ISP	Information Service Provider	W	messaging data	
145	RTS	Remote Traveler Support	demand responsive transit request	ISP	Information Service Provider	W	messaging data	
146	RTS	Remote Traveler Support	emergency notification	TRMS	Transit Management	W	Conversational data, Messaging Data	
147	RTS	Remote Traveler Support	transit request	TRMS	Transit Management	W	messaging data	
148	RTS	Remote Traveler Support	traveler information request	TRMS	Transit Management	W	messaging data	
149	RTS	Remote Traveler Support	map update request	X23	Map Update Provider	W	messaging data	
150	TAS	Toll Administration	toll schedules	ISP	Information Service Provider	W	messaging data	
151	TAS	Toll Administration	operational data	PS	Planning Subsystem	W	messaging data	
152	TAS	Toll Administration	toll instructions	TCS	Toll Collection	W	messaging data	
153	TAS	Toll Administration	demand management price change response	TMS	Traffic Management	W	messaging data	
154	TAS	Toll Administration	probe data	TMS	Traffic Management	W	messaging data	
156	TAS	Toll Administration	payment request	X21	Financial Institution	W	messaging data	
157	TAS	Toll Administration	toll revenues and summary reports	X44	Toll Service Provider	W	messaging data	
158	TAS	Toll Administration	violation notification	X62	Enforcement Agency	W	messaging data	
159	TAS	Toll Administration	license request	X64	DMV	W	messaging data	
160	TCS	Toll Collection	toll transactions	TAS	Toll Administration	W	messaging data	
161	TCS	Toll Collection	tag update	VS	Vehicle	U2	Conversational Data	Data communication while passing by specific locations at speeds up to 70 mph
162	TCS	Toll Collection	request tag data	VS	Vehicle	U2	Conversational data	Data communication while passing by specific locations at speeds up to 70 mph

**Table A.5-1 Data Flow – Communications Service Mapping (Cont'd)**

W = Wireline  
U1t = Wireless wide area interface

U1b = Wireless wide area one-way broadcast  
U2 = Short range (close proximity) vehicle to roadside wireless interface

Flow #	Source	Source Name	Architecture Flow	Destination	Destination Name	Interconnects	Communication Service	Rationale
163	TMS	Traffic Management	incident information request	EM	Emergency Management	W	Messaging data	
164	TMS	Traffic Management	incident notification	EM	Emergency Management	W	Messaging data	
165	TMS	Traffic Management	pollution state data request	EMMS	Emissions Management	W	messaging data	
166	TMS	Traffic Management	traffic information	ISP	Information Service Provider	W	messaging data	
167	TMS	Traffic Management	parking instructions	PMS	Parking Management	W	messaging data	
168	TMS	Traffic Management	demand management price change request	PMS	Parking Management	W	messaging data	
169	TMS	Traffic Management	operational data	PS	Planning Subsystem	W	messaging data	
170	TMS	Traffic Management	freeway control data	RS	Roadway Subsystem	W	messaging data	
171	TMS	Traffic Management	signal control data	RS	Roadway Subsystem	W	messaging data	
172	TMS	Traffic Management	AHS control information	RS	Roadway Subsystem	W	messaging data	
173	TMS	Traffic Management	signage data	RS	Roadway Subsystem	W	messaging data	
174	TMS	Traffic Management	demand management price change request	TAS	Toll Administration	W	messaging data	
175	TMS	Traffic Management	traffic information	TRMS	Transit Management	W	messaging data	
176	TMS	Traffic Management	demand management price change request	TRMS	Transit Management	W	messaging data	
177	TMS	Traffic Management	signal priority status	TRMS	Transit Management	W	Conversational data, messaging data	
178	TMS	Traffic Management	event confirmation	X19	Event Promoters	W	messaging data	
179	TMS	Traffic Management	map update request	X23	Map Update Provider	W	messaging data	
180	TMS	Traffic Management	TMC coord.	X35	Other TM	W	messaging data	
181	TMS	Traffic Management	violation notification	X62	Enforcement Agency	W	messaging data	
182	TMS	Traffic Management	license request	X64	DMV	W	messaging data	
183	TRMS	Transit Management	security alarms	EM	Emergency Management	W	Conversational data, messaging data, location data	Location data for emergency response
184	TRMS	Transit Management	demand responsive transit plan	ISP	Information Service Provider	W	Conversational data, messaging data	
185	TRMS	Transit Management	transit and fare schedules	ISP	Information Service Provider	W	messaging data	
186	TRMS	Transit Management	transit request confirmation	ISP	Information Service Provider	W	messaging data	
187	TRMS	Transit Management	demand responsive transit route	PIAS	Personal Information Access	W,U1t	messaging data	Bursty data



**Table A.5-1 Data Flow – Communications Service Mapping (Cont'd)**

W = Wireline  
U1t = Wireless wide area interface

U1b = Wireless wide area one-way broadcast  
U2 = Short range (close proximity) vehicle to roadside wireless interface

Flow #	Source	Source Name	Architecture Flow	Destination	Destination Name	Interconnects	Communication Service	Rationale
188	TRMS	Transit Management	parking lot transit response	PMS	Parking Management	W	messaging data, Broadcast data, Multicast	
189	TRMS	Transit Management	operational data	PS	Planning Subsystem	W	messaging data	
190	TRMS	Transit Management	traveler information	RTS	Remote Traveler Support	W	messaging data, Multicast data	
191	TRMS	Transit Management	transit and fare schedules	RTS	Remote Traveler Support	W	messaging data, Multicast data	
192	TRMS	Transit Management	emergency acknowledge	RTS	Remote Traveler Support	W	Conversational data, messaging data	
193	TRMS	Transit Management	request for transit signal priority	TMS	Traffic Management	W	messaging data	
194	TRMS	Transit Management	demand management price change response	TMS	Traffic Management	W	messaging data	
195	TRMS	Transit Management	emergency acknowledge	TRVS	Transit Vehicle Subsystem	U1t	Conversational data, messaging data	Minimum delay may be required
196	TRMS	Transit Management	driver instructions	TRVS	Transit Vehicle Subsystem	U1t	messaging data	
197	TRMS	Transit Management	bad tag list	TRVS	Transit Vehicle Subsystem	U1t	messaging data	Bursty data
198	TRMS	Transit Management	request for vehicle measures	TRVS	Transit Vehicle Subsystem	U1t,U2	Conversational data, messaging data	Bursty data using widearea wireless or short rang while passing by specific locations at speeds up to 70 mph
199	TRMS	Transit Management	schedules, fare info request	TRVS	Transit Vehicle Subsystem	U1t	messaging data	Bursty data
200	TRMS	Transit Management	traveler information	TRVS	Transit Vehicle Subsystem	U1t	messaging data	Bursty data
201	TRMS	Transit Management	route assignment	TRVS	Transit Vehicle Subsystem	U1t,U2	messaging data	Bursty data using widearea wireless or short rang while passing by specific locations at speeds up to 70 mph
202	TRMS	Transit Management	intermodal information	X02	Intermodal Transportation Service Provider	W	messaging data	
203	TRMS	Transit Management	payment request	X21	Financial Institution	W	Conversational data, messaging data	
204	TRMS	Transit Management	map update request	X23	Map Update Provider	W	messaging data	
205	TRMS	Transit Management	TRMS coord	X33	Other TRM	W	messaging data	
206	TRMS	Transit Management	camera control	X42	Secure Area	W	Conversational data,	

**Table A.5-1 Data Flow – Communications Service Mapping (Cont'd)**

W = Wireline  
U1t = Wireless wide area interface

U1b = Wireless wide area one-way broadcast  
U2 = Short range (close proximity) vehicle to roadside wireless interface

Flow #	Source	Source Name	Architecture Flow	Destination	Destination Name	Interconnects	Communication Service	Rationale
					Environment		messaging data	
207	TRMS	Transit Management	violation notification	X62	Enforcement Agency	W	messaging data	
208	TRVS	Transit Vehicle Subsystem	local signal priority request	RS	Roadway Subsystem	U2	Conversational data	Data communication while passing by specific locations at speeds up to 70 mph
209	TRVS	Transit Vehicle Subsystem	transit vehicle conditions	TRMS	Transit Management	U1t,U2	messaging data	Bursty data using widearea wireless or short rang while passing by specific locations at speeds up to 70 mph
210	TRVS	Transit Vehicle Subsystem	vehicle probe data	TRMS	Transit Management	U1t	Conversational data, messaging data, location data	Bursty data
211	TRVS	Transit Vehicle Subsystem	traveler information request	TRMS	Transit Management	U1t	Conversational data, messaging data	
212	TRVS	Transit Vehicle Subsystem	emergency notification	TRMS	Transit Management	U1t	messaging data	
213	TRVS	Transit Vehicle Subsystem	fare and payment status	TRMS	Transit Management	U1t,U2	Conversational data, messaging data	Bursty data using widearea wireless or short rang while passing by specific locations at speeds up to 70 mph
214	TRVS	Transit Vehicle Subsystem	transit vehicle passenger and use data	TRMS	Transit Management	U1t,U2	Conversational data, messaging data	Bursty data using widearea wireless or short rang while passing by specific locations at speeds up to 70 mph
215	TRVS	Transit Vehicle Subsystem	traveler advisory request	VS	Vehicle	W	Messaging data	
216	VS	Vehicle	cargo data request	CVS	Commercial Vehicle Subsystem	W	Messaging data	
217	VS	Vehicle	emergency notification	EM	Emergency Management	U1t	Conversational speech, messaging data, location data	Bursty data and live speech. Location data for emergency response
218	VS	Vehicle	vehicle location	EVS	Emergency Vehicle Subsystem	W	Broadcast data	
219	VS	Vehicle	traveler information request	ISP	Information Service Provider	U1t	Conversational data, messaging data	
220	VS	Vehicle	trip request	ISP	Information Service Provider	U1t	Conversational data, messaging data	Busrty data
221	VS	Vehicle	trip confirmation	ISP	Information Service Provider	U1t	Conversational data, messaging data	Busrty data
222	VS	Vehicle	vehicle probe data	ISP	Information Service	U1t	messaging data, location	Busrty data

**Table A.5-1 Data Flow – Communications Service Mapping (Cont'd)**

W = Wireline  
U1t = Wireless wide area interface

U1b = Wireless wide area one-way broadcast  
U2 = Short range (close proximity) vehicle to roadside wireless interface

Flow #	Source	Source Name	Architecture Flow	Destination	Destination Name	Interconnects	Communication Service	Rationale
					Provider		data	
223	VS	Vehicle	yellow pages request	ISP	Information Service Provider	U1t	Conversational data, messaging data	
224	VS	Vehicle	tag data	PMS	Parking Management	U2	Conversational data	Data communication while passing by specific locations at speeds up to 70 mph
225	VS	Vehicle	AHS vehicle data	RS	Roadway Subsystem	U2	Conversational data	Data communication while passing by specific locations at speeds up to 70 mph
226	VS	Vehicle	vehicle probe data	RS	Roadway Subsystem	U2	Messaging Data	Data communication while passing by specific locations at speeds up to 70 mph
227	VS	Vehicle	tag data	TCS	Toll Collection	U2	Conversational data	Data communication while passing by specific locations at speeds up to 70 mph
228	VS	Vehicle	vehicle location	TRVS	Transit Vehicle Subsystem	W	Broadcast data	
229	VS	Vehicle	vehicle control	X03	Basic Vehicle	W	Conversational Data	
230	VS	Vehicle	map update request	X23	Map Update Provider	U1t	messaging data	Busrty data
231	X01	Intermodal Freight Shipper	intermod CVO coord	FMS	Fleet and Freight Management	W	messaging data	
232	X02	Intermodal Transportation Service Provider	intermodal information	ISP	Information Service Provider	W	messaging data	
233	X02	Intermodal Transportation Service Provider	intermodal information	TRMS	Transit Management	W	messaging data	
234	X03	Basic Vehicle	vehicle measures	VS	Vehicle	W	Broadcast data	
235	X08	Commercial Vehicle	vehicle measures	CVS	Commercial Vehicle Subsystem	W	Broadcast data	
236	X10	CVO Inspector	CVC override mode	CVCS	Commercial Vehicle Check	U2	Conversational data, messaging data	
237	X13	E911 or ETS	incident information	EM	Emergency Management	W	Conversational data conversational spec, location data	Location data for emergency response
238	X19	Event Promoters	event plans	TMS	Traffic Management	W	messaging data, Multicast data	
239	X21	Financial Institution	transaction status	CVAS	Commercial Vehicle Administration	W	Conversational data, messaging data	
240	X21	Financial Institution	transaction status	ISP	Information Service	W	Conversational data,	

**Table A.5-1 Data Flow – Communications Service Mapping (Cont'd)**

W = Wireline  
U1t = Wireless wide area interface

U1b = Wireless wide area one-way broadcast  
U2 = Short range (close proximity) vehicle to roadside wireless interface

Flow #	Source	Source Name	Architecture Flow	Destination	Destination Name	Interconnects	Communication Service	Rationale
					Provider		messaging data	
241	X21	Financial Institution	transaction status	PMS	Parking Management	W	Conversational data, messaging data	
242	X21	Financial Institution	transaction status	TAS	Toll Administration	W	Conversational data, messaging data	
243	X21	Financial Institution	transaction status	TRMS	Transit Management	W	Conversational data, messaging data	
244	X22	Government Administrators	regulations	CVAS	Commercial Vehicle Administration	W	messaging data, Multicast data	
245	X23	Map Update Provider	map updates	EM	Emergency Management	W	messaging data, Multicast data	
246	X23	Map Update Provider	map updates	EMMS	Emissions Management	W	messaging data	
247	X23	Map Update Provider	map updates	ISP	Information Service Provider	W	messaging data, Multicast data	
248	X23	Map Update Provider	map updates	PIAS	Personal Information Access	W,U1t	messaging data, Multicast data	Service on request or by subscription
249	X23	Map Update Provider	map updates	PS	Planning Subsystem	W	messaging data, Broadcast data, Multicast	
250	X23	Map Update Provider	map updates	RTS	Remote Traveler Support	W	messaging data	
251	X23	Map Update Provider	map updates	TMS	Traffic Management	W	messaging data, Multicast data	
252	X23	Map Update Provider	map updates	TRMS	Transit Management	W	messaging data, Multicast data	
253	X23	Map Update Provider	map updates	VS	Vehicle	U1t	messaging data, Multicast data	Service on request or by subscription
254	X24	Yellow Pages Service Providers	travel service info	ISP	Information Service Provider	W	messaging data	
255	X25	Transportation Planners	planning data	PS	Planning Subsystem	W	messaging data	
256	X27	Media	external reports	ISP	Information Service Provider	W	messaging data, Multicast data	
257	X28	Media Operator	incident notification	ISP	Information Service Provider	W	messaging data, Broadcast data, Multicast	
258	X29	Multimodal Crossings	right of way preemption request	RS	Roadway Subsystem	W	Conversational data, messaging data	
259	X29	Multimodal Crossings	request for right of way	RS	Roadway Subsystem	W	Conversational data,	

**Table A.5-1 Data Flow – Communications Service Mapping (Cont'd)**

W = Wireline  
U1t = Wireless wide area interface

U1b = Wireless wide area one-way broadcast  
U2 = Short range (close proximity) vehicle to roadside wireless interface

Flow #	Source	Source Name	Architecture Flow	Destination	Destination Name	Interconnects	Communication Service	Rationale
							messaging data	
260	X30	Other EM	emergency coordination	EM	Emergency Management	W	Conversational data, messaging data	
261	X31	Other ISP	ISP coord	ISP	Information Service Provider	W	messaging data	
262	X33	Other TRM	TRMS coord	TRMS	Transit Management	W	messaging data	
263	X35	Other TM	TMC coord.	TMS	Traffic Management	W	messaging data	
264	X37	Parking Service Provider	request for performance data	PMS	Parking Management	W	messaging data	
265	X51	Transit Vehicle	vehicle measures	TRVS	Transit Vehicle Subsystem	W	Broadcast data	
266	X58	Weather Service	weather information	ISP	Information Service Provider	W	messaging data, Broadcast data, Multicast	
267	X58	Weather Service	weather information	TMS	Traffic Management	W	messaging data, Broadcast data, Multicast	
268	X59	Other CVAS	CVAS information exchange	CVAS	Commercial Vehicle Administration	W	messaging data	
269	X59	Other CVAS	credentials and safety information response	CVAS	Commercial Vehicle Administration	W	messaging data	
270	X60	Intermodal Freight Depot	intermod CVO coord	FMS	Fleet and Freight Management	W	messaging data	
271	X64	DMV	registration	CVAS	Commercial Vehicle Administration	W	messaging data	
272	X64	DMV	vehicle characteristics	PMS	Parking Management	W	Messaging data	
273	X64	DMV	registration	TAS	Toll Administration	W	messaging data	
274	X64	DMV	registration	TMS	Traffic Management	W	messaging data	
275	X65	CVO Information Requestor	credentials and safety information request	CVAS	Commercial Vehicle Administration	W	messaging data	

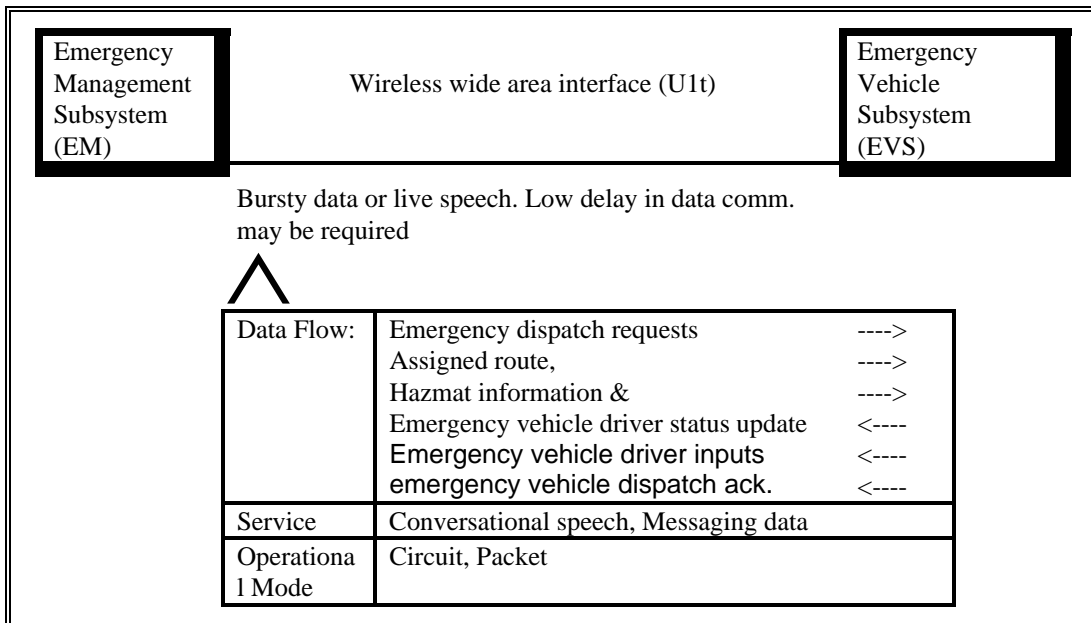
## **APPENDIX B ARCHITECTURE INTERCONNECT DIAGRAMS**

### **LEVEL 1**

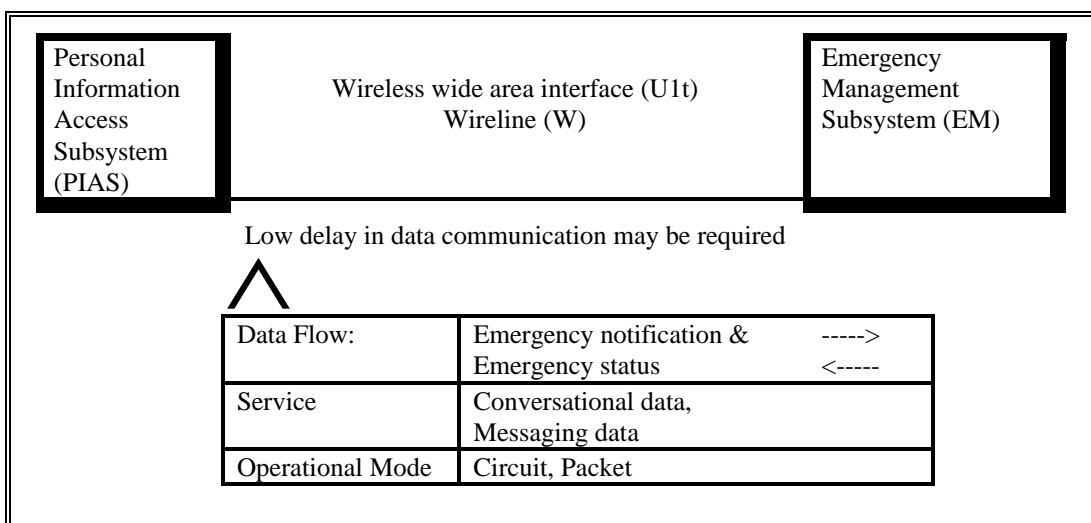
Using the AID template and the Data Flow - Communication Services Mapping table presented in Appendix A, a sample set of the data flows are represented in an Architecture Interconnect Diagram (AID) format. Each AID may represent more than one data flow. Whereas many of the AIDs support messaging and conversational data, in many cases they can also be supported by conversational speech. In fact, near-term deployments of applications like pre-trip planning or en-route driver advisories will probably disseminate information verbally rather than via bit streams. Thus providing for this in the analysis supports both rural deployments, and early deployment in any location. In rural areas providing new infrastructure will most likely be expensive until enough other demand is reached or older existing equipment must be replaced.

The substantiation for the operation mode is based on the nature of the data flow (*e.g.*, anticipated frequency of use, message length, qualitative rationale). The operation mode was refined and calibrated with information from Section 6, Data Loading Analysis.

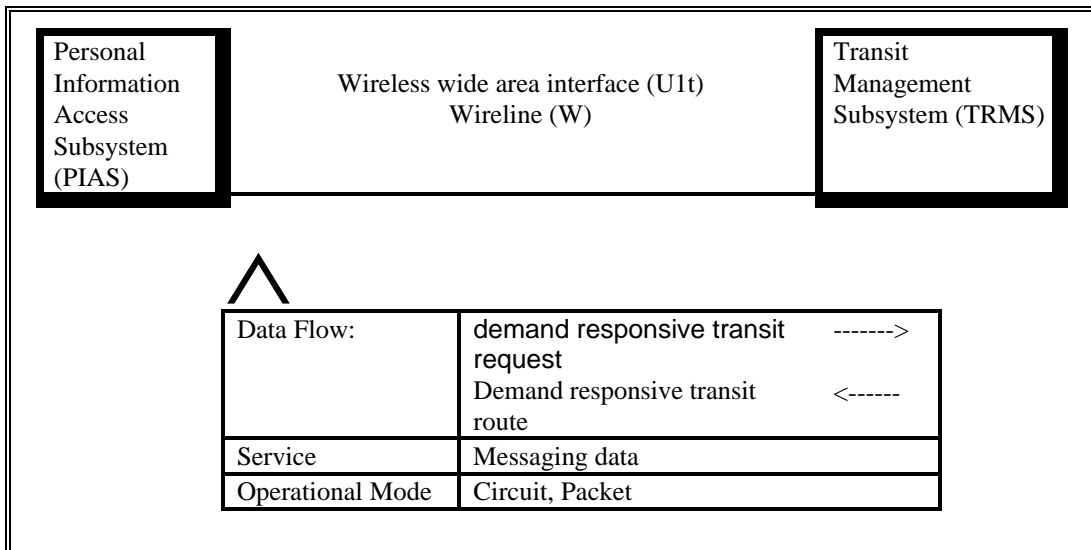
Figures B-1 through B-17 are a sample set of the AIDs for the inter-entity links, indicating the physical medium, wireline (*w*) or wireless ( $u_1, u_2, u_3$ ) and the mode of operation (*e.g.*, circuit, packet) and carrying forward the service types (conversational speech, conversational data, messaging data, broadcast data and/or multicast data) from the Data Flow - Communication Services Mapping Table. The figures show the flow from the left entity to the right entity, unless specifically indicated for that flow (which occurs when there are flows in both directions).



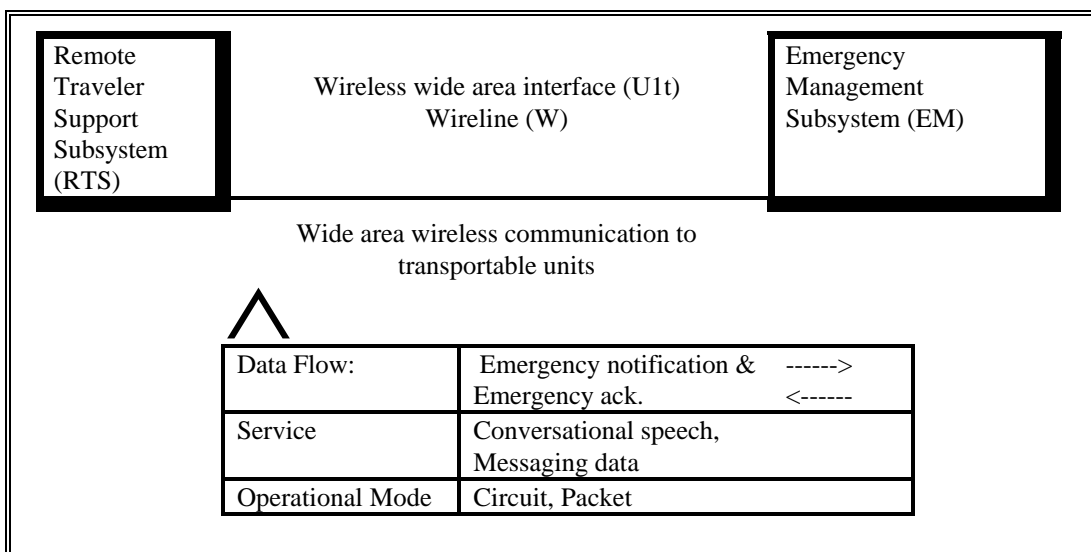
**Figure B-1 First Level EM - EVS AID**



**Figure B-2 First Level PIAS-EM AID**

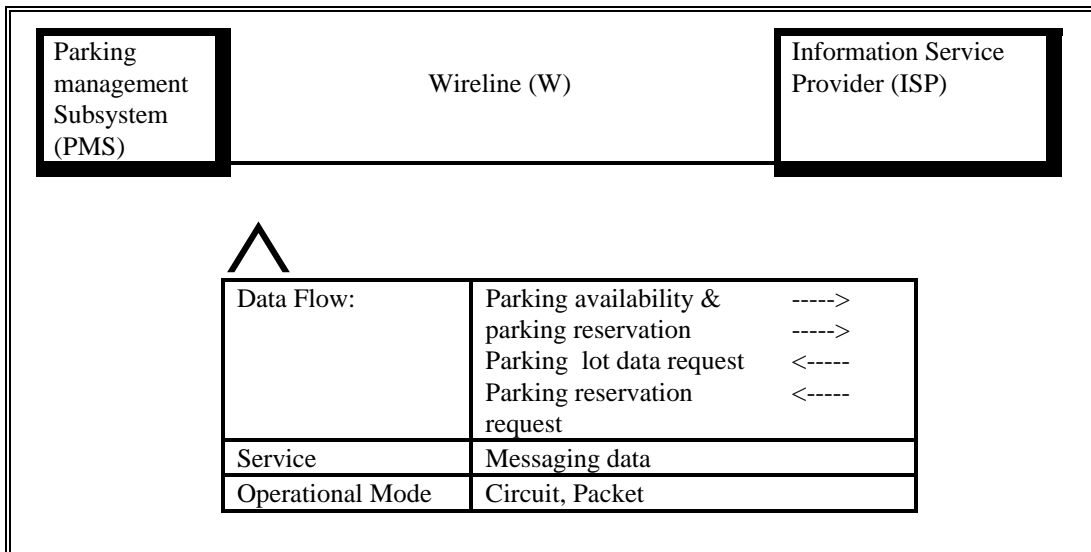


**Figure B-3 First Level PIAS-TRMS AID**

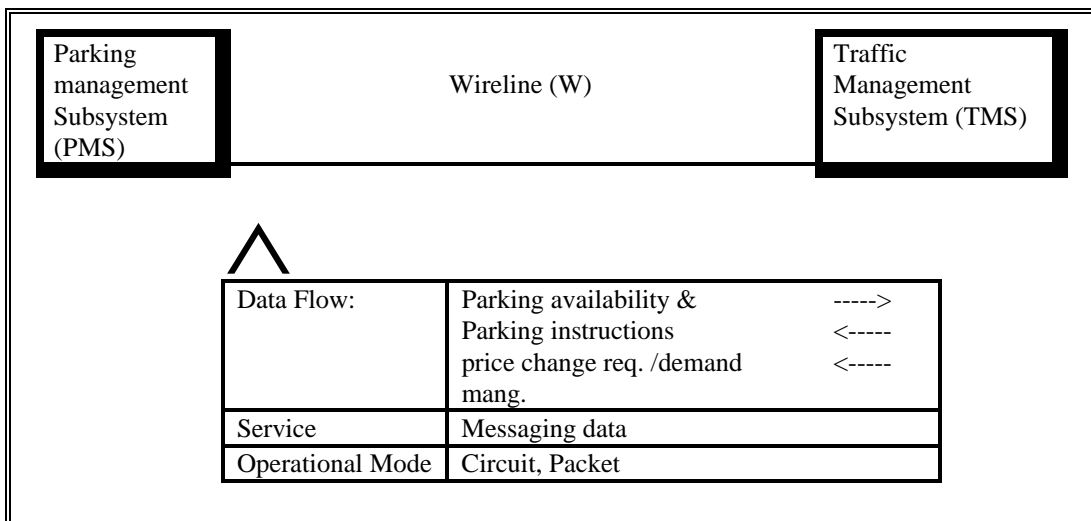


**Figure B-4 First Level RTS-EM AID**

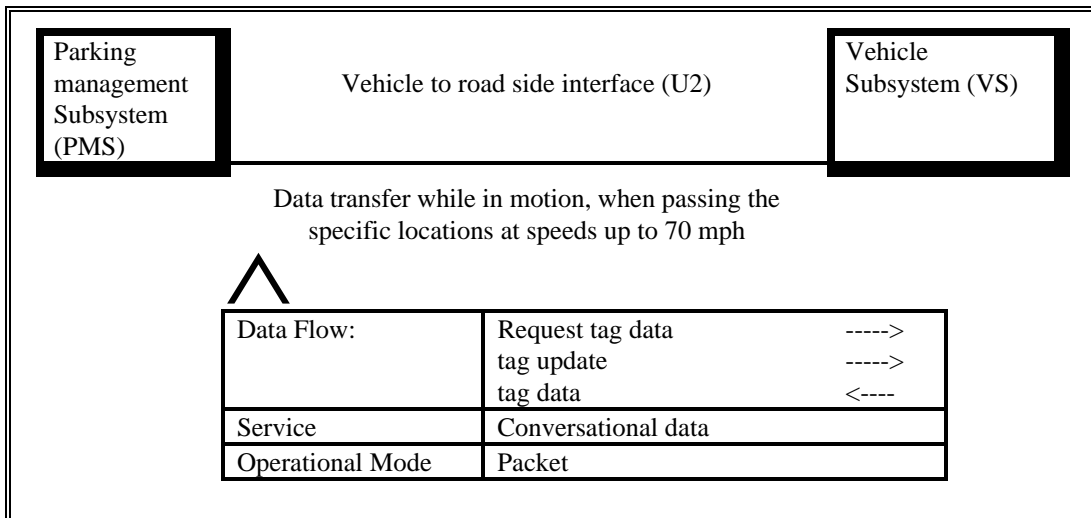




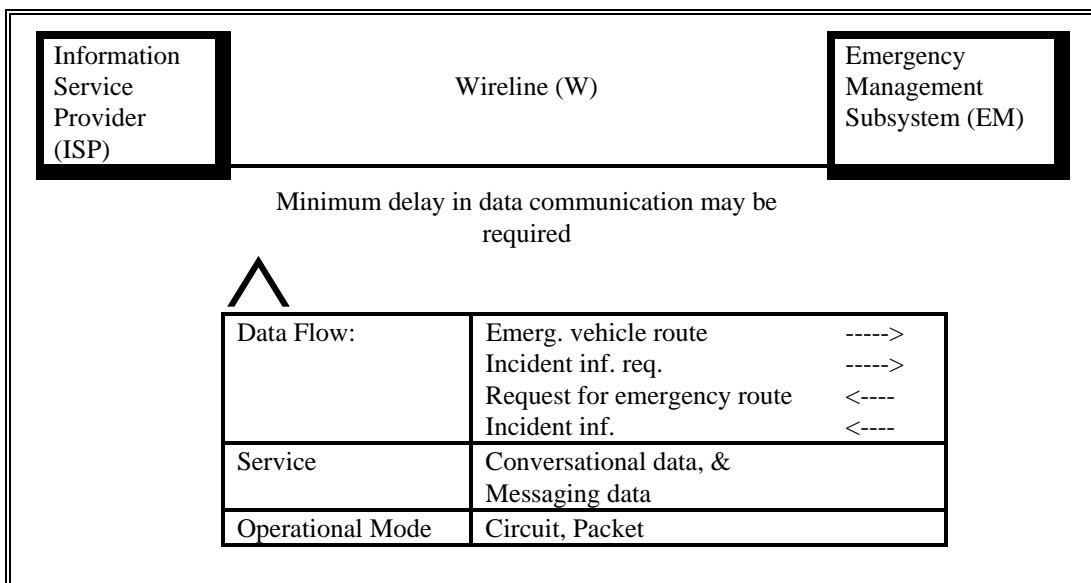
**Figure B-5 First Level PMS-ISP AID**



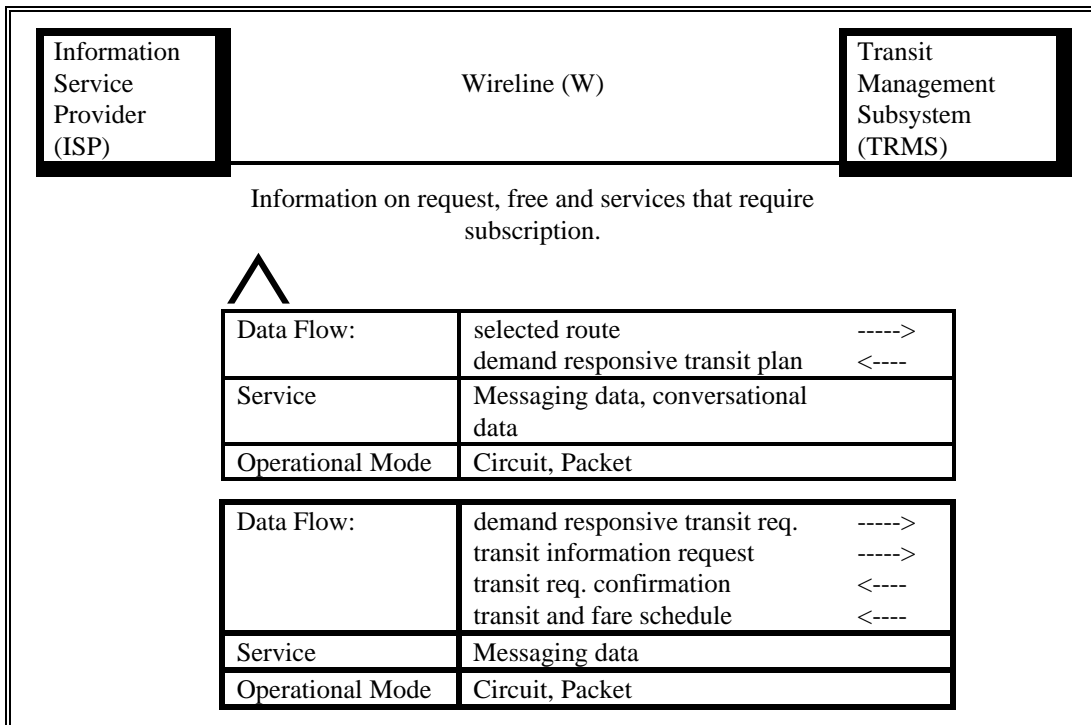
**Figure B-6 First Level PMS-TMS AID**



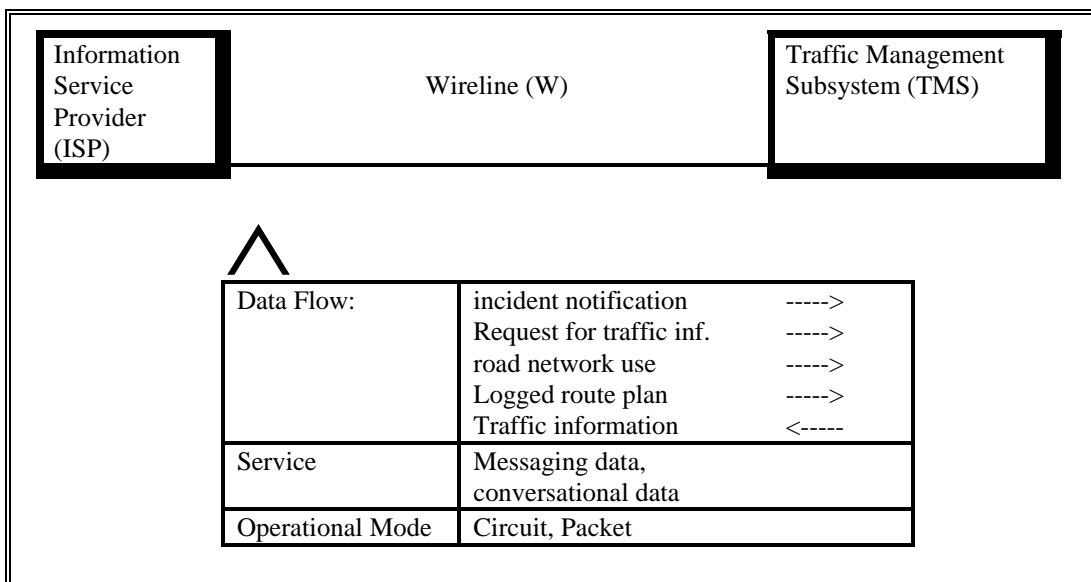
**Figure B-7 First Level PMS-VS AID**



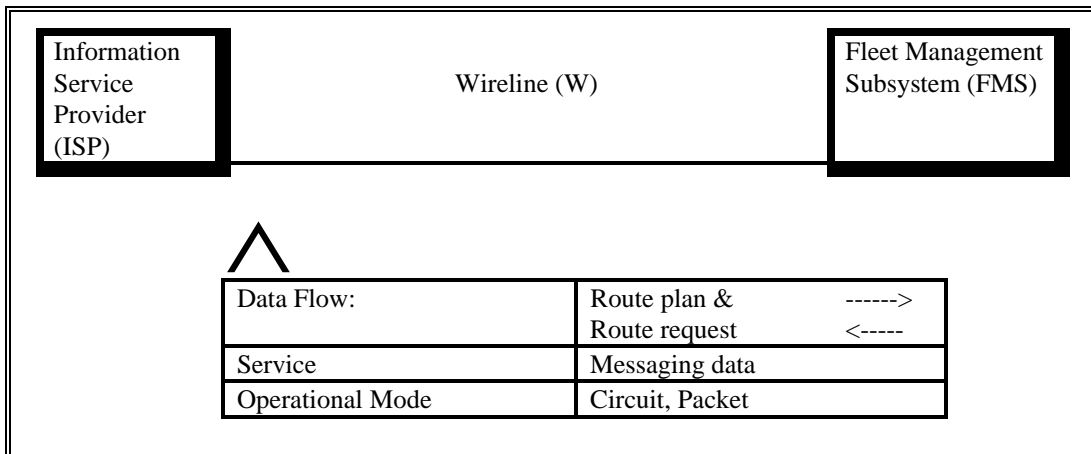
**Figure B-8 First Level ISP-EM AID**



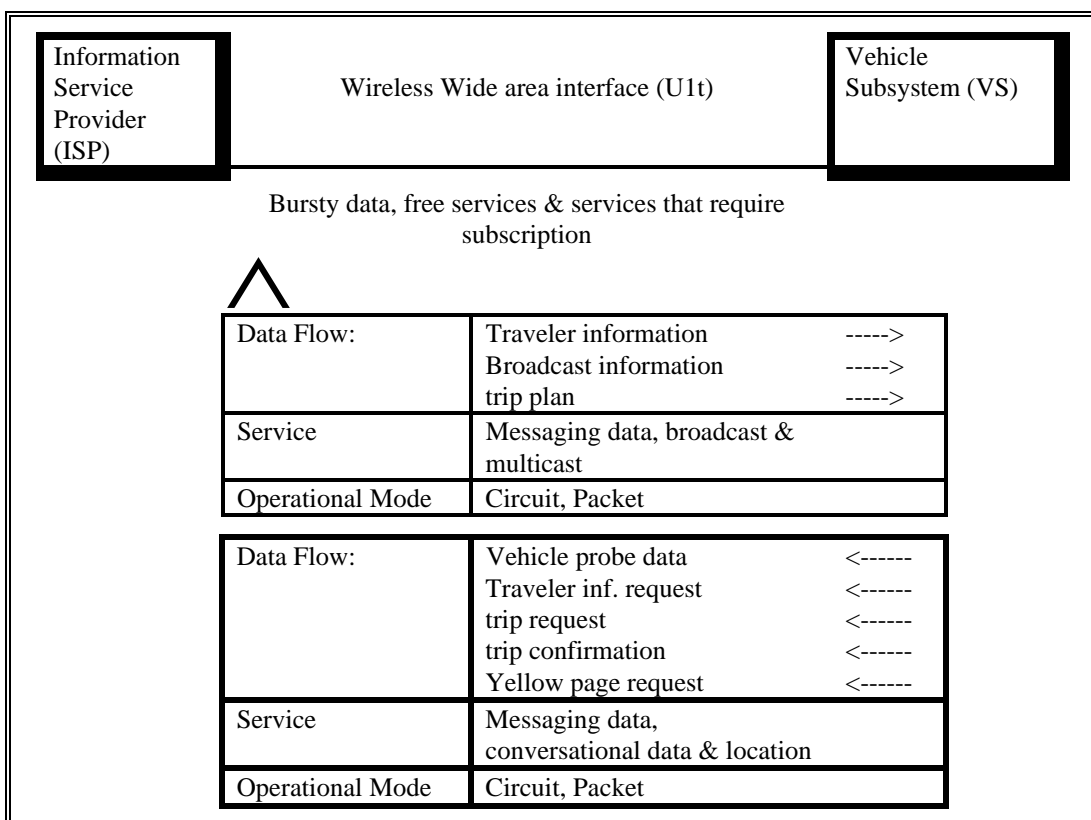
**Figure B-9 First Level ISP-TRMS AID**



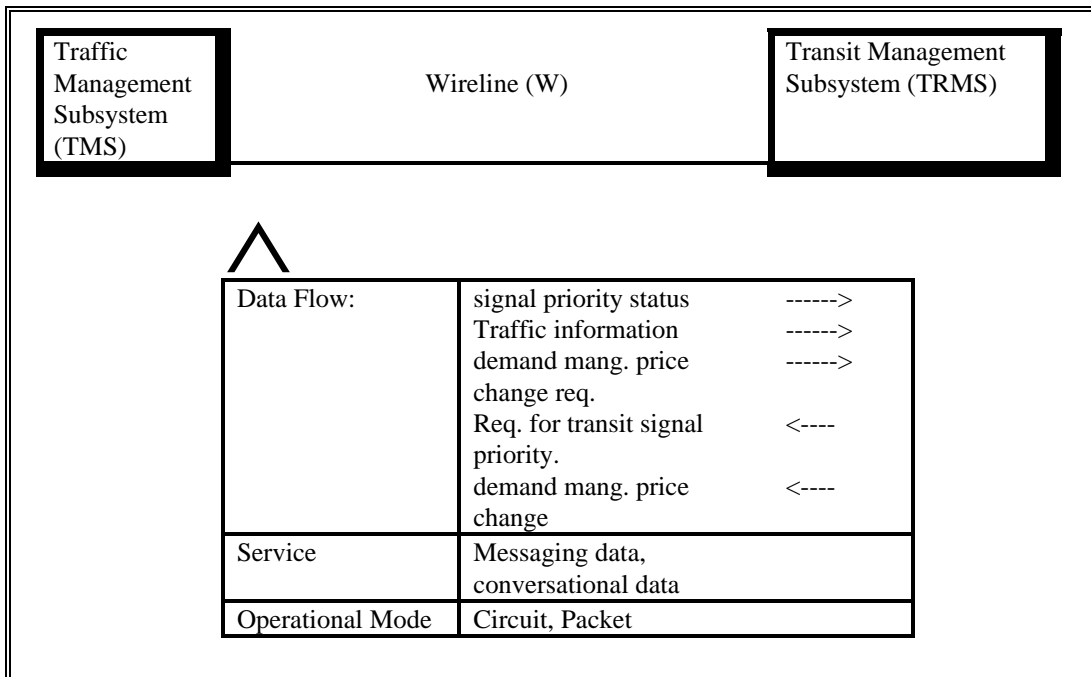
**Figure B-10 First Level ISP-TMS AID**



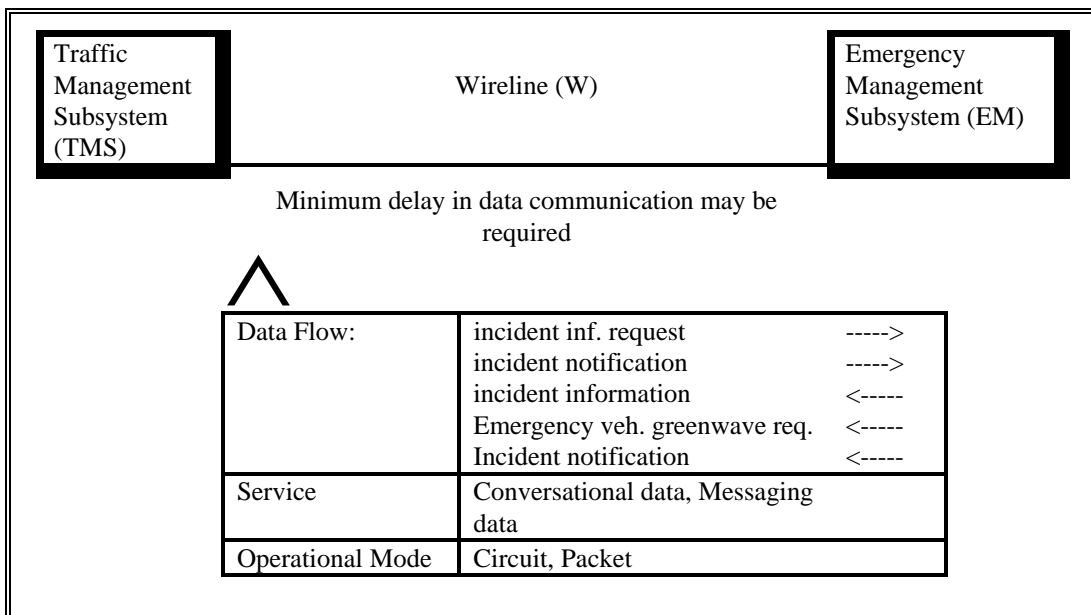
**Figure B-11 First Level ISP-FMS AID**



**Figure B-12 First Level ISP-VS AID**



**Figure B-13 First Level TMS-TRMS AID**



**Figure B-14 First Level TMS-EM AID**

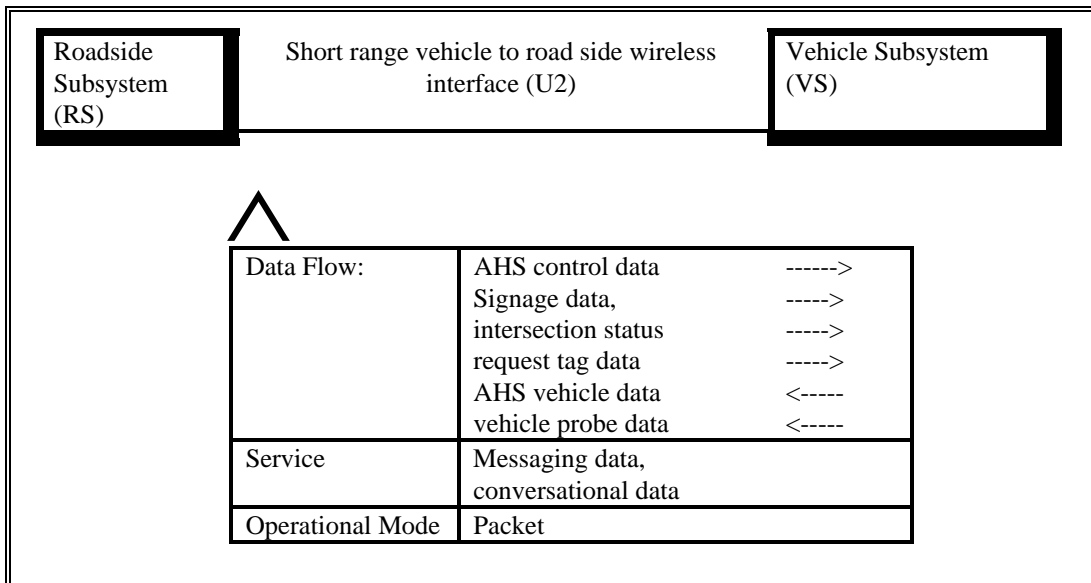
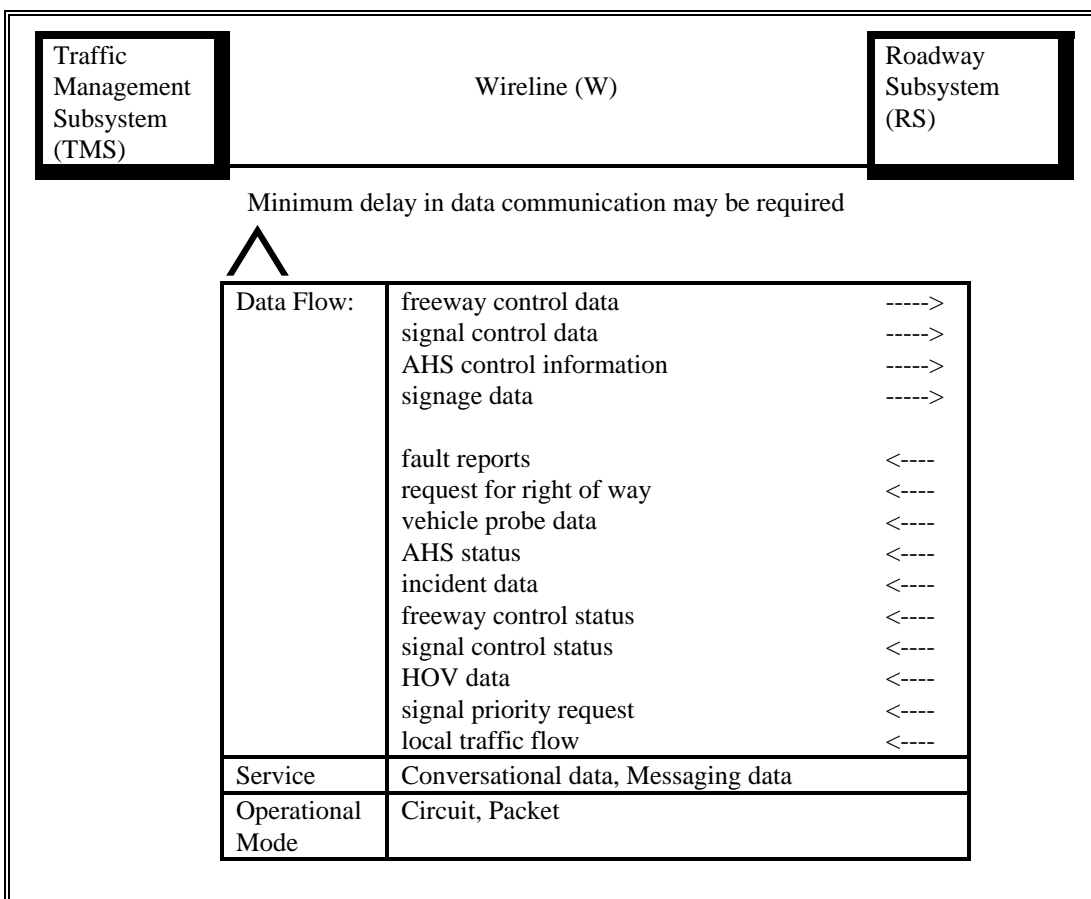
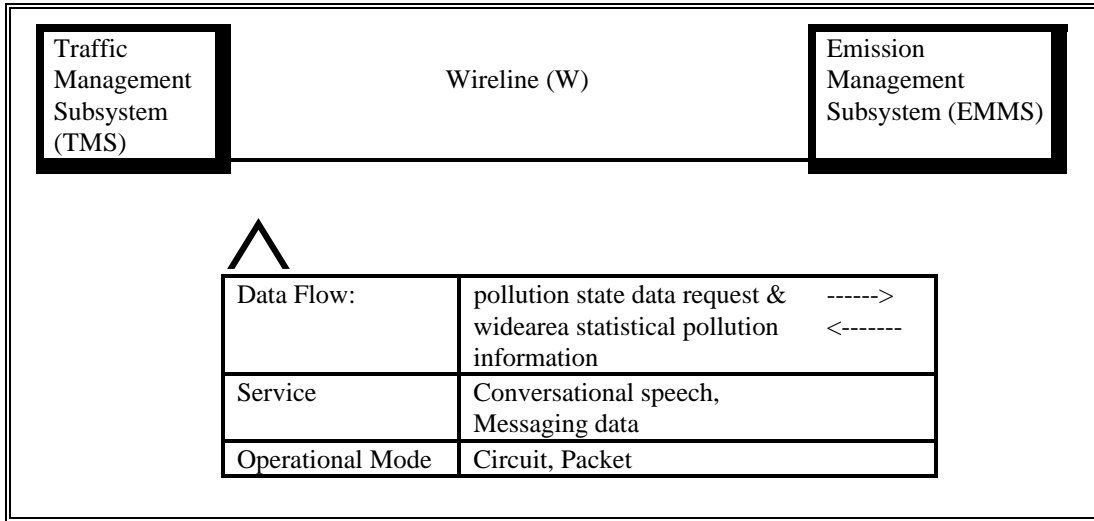


Figure B-15 First Level RS-VS AID



**Figure B-16 First Level TMS-RS AID**

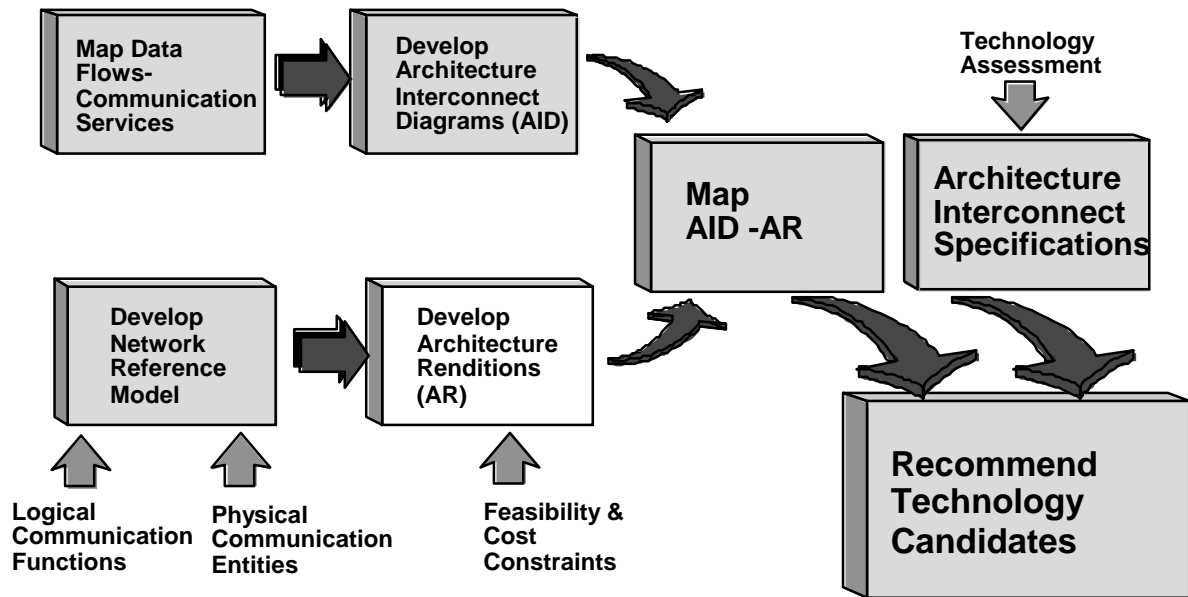


**Figure B-17 First Level TMS-EMMS AID**

## **APPENDIX C COMMUNICATION ARCHITECTURE RENDITIONS AND APPLICABLE TECHNOLOGIES**

Section C.1 of this appendix provides information that represents the next step in the communications architecture design process – the development of the Communication Architecture Renditions. This activity is denoted as the highlighted block in Figure C.0-1. The architecture renditions are essentially examples of how to provide connections between users based on the communications network reference model and the evaluations of feasible implementations. In addition, to save the re-listing of the renditions, each rendition is combined with the listing of the data flows supported by that rendition. This effectively provides a map between the renditions and the Architecture Interconnect Diagrams (AIDs). Section C.2 provides an example of mapping applicable communication technologies to the renditions.





**Figure C.0-1 Communications Architecture Development Process – Develop Architecture Renditions**

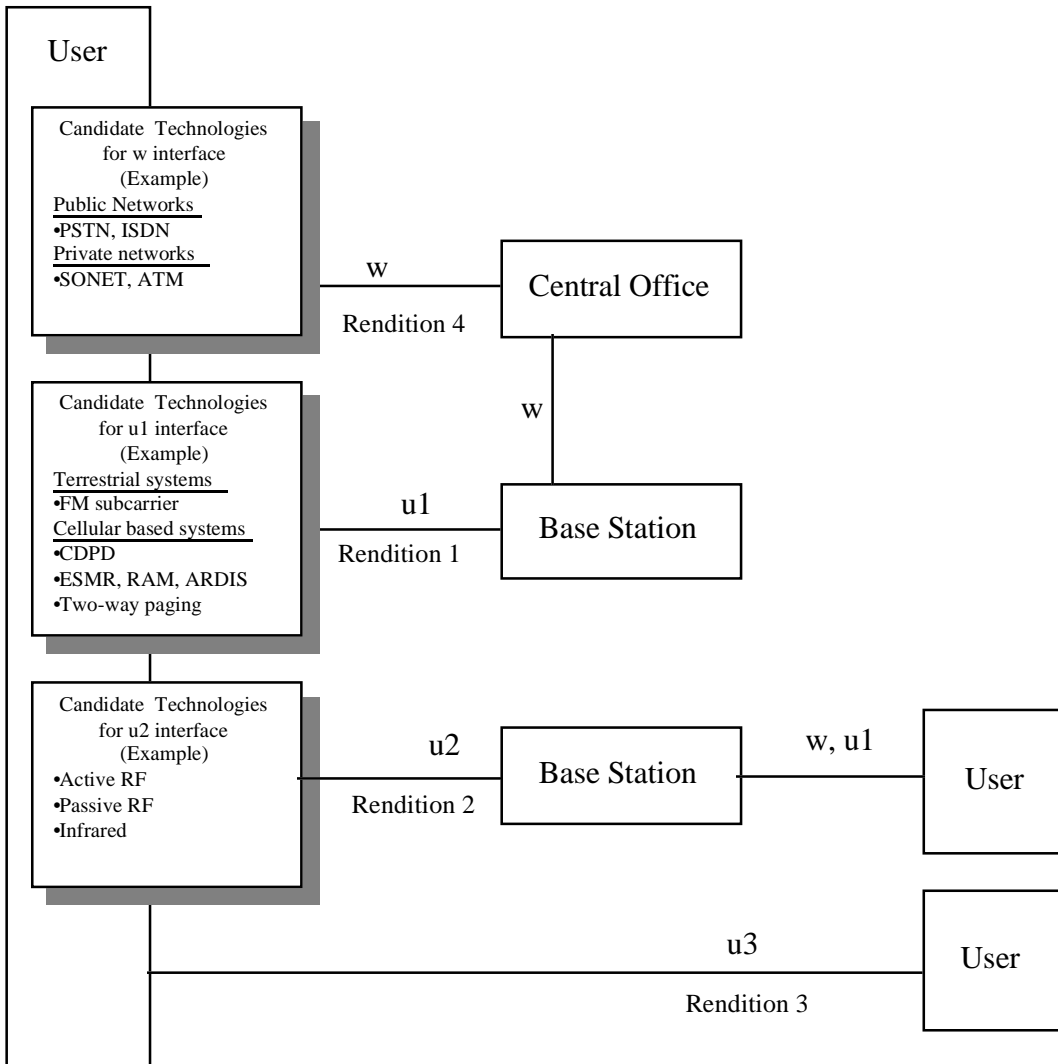
### C.1 Format/Purpose

The previous sections have identified the physical entities and the communication services required between them. The task now is to show how user-to-user communication paths are built up from combinations of the identified wireline and wireless links, and to show that the user's needs are met by the identified communication services. This is accomplished by establishing a set of renditions which illustrate the connectivities provided by  $w$  and  $u$  links. A Level 1 rendition is generated for each of the possible interconnections between these services, except three which do not meet the needs of the architecture. Again the Level 0 Rendition, which shows the full connectivity between users over multiple links, appears before the Level 1 renditions from which it was developed.

#### C.1.1 Level 0 Rendition

The Level 0 rendition (Figure C.1-1) represents a composition of all the renditions to reflect the combined needs of the architecture. The left side shows a general user with any one or all four possible communication links and how those links connect the user to other users.

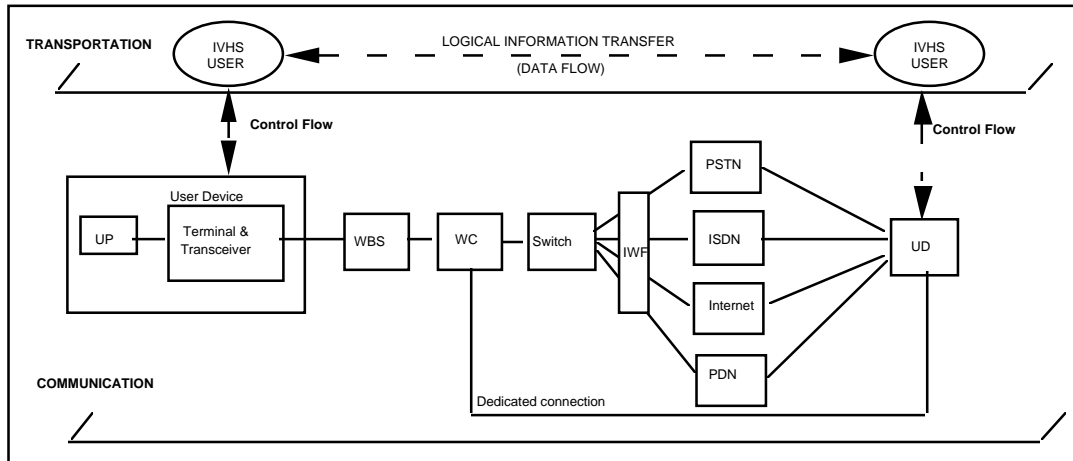
The Level 0 Rendition shows a generic user communicating to another user over one of the four communication types ( $w, u_1, u_2, u_3$ ), where the medium/long and short distance radio based communication ( $u_1$  and  $u_2$ , respectively) travels through a base station (the wireline almost without exception will pass through a central office or at least a user concentrator/switch) and the vehicle-to-vehicle radio ( $u_3$ ) uses no intermediary.



**Figure C.1-1 Level 0 Rendition**

### C.1.2 Level 1 Rendition

Figure C.1-2 illustrates the interaction between the users and the underlying communication architecture. Given the choice of communication services and operation modes (*i.e.*, circuit versus packet versus non-switched), several renditions of this general model are possible (these may be supported by a single communication infrastructure).



**Figure C.1-2 Communication Architecture – Transportation Layer Interaction**

The communication architecture in Figure C.1-2 shows multiple functions necessary to deliver data from or to a mobile ITS user to or from a stationary user, respectively. Because the path from stationary user to stationary user makes use of the wireline component in all but a few data flows, the best path makes use of the existing infrastructure provided by public communications service providers such as the local Telco in all but a few exceptional locations. In those locations ITS users may deploy their own dedicated system; even then that connection will be interconnected to, and therefore appear as an extension of, the existing public system.

To simplify the presentation, the end-to-end model represented by Figure C.1-2 is broken into those types which are of direct interest to the ITS architecture: the  $u_1$ ,  $u_2$ ,  $u_3$ , and  $w$ , those at each end of the link for which the interface to the communications service provider is not transparent to the system. Thus four renditions are given, one for each of the  $u$  and  $w$  types of link. The gathering deployment of digital cellular and other digital radio technologies bolsters the assumption that the tetherless (mobile) user will have a digital connection to other users connected to the group of base stations and, in most locations, to the local communications service provider.

**Rendition 1: ( $u_1$ )**

The  $u_1$  link is required to provide (part way) service between tetherless and both other tetherless users and stationary users. The  $u_1$  link includes the two-way wireless link  $u_{1t}$  and the broadcast link  $u_{1b}$ . As shown in Figure C.1-3a, the  $u_{1t}$  link end-to-end service for tetherless users connected to the same base station or base stations with dedicated connections. In the near term this is mostly an analog service but evolving to digital over the next few years. The service may use one or more of the technologies listed in Appendix D, Technology Survey and Assessment. When users have different technologies not supported by the same base station, the public switched network (PSTN) typically provides the connection between the different base stations. For communication between tetherless and stationary users, the  $u_{1t}$  link connects the tetherless user to the base station and the public telco. The wireline portion of the connection is considered secondary to the wireless link in its criticality.

u1t interconnection between tetherless users and stationary users would be digital except in some instances (including rural where the local telco service has not yet been digitized). In that case, while the fixed portion of the network supports circuit-mode operation, it cannot exchange digital signals. A modem bank interconnected to the Mobile Switching Center (MSC) initiates a call setup to the target application. A modem at the target user converts the signal to digital data. A call from a stationary user is routed through the telco or one of the Internet-like networks to the base station in the reverse process and then a channel, either circuit-switched (primarily for voice or large messages) or packet-switched (primarily for data but also voice) to the tetherless user is identified. Thus, the logical connection between the two users in the transportation plane is satisfied. Because of the short nature of all currently identified messages, most will use packet switching whenever that option is available. This rendition supports the data flows, listed in Table C.1-1a.

Figure C.1-3b depicts the rendition for  $u_{1b}$ . This link can support low rate one-way wireless data services. It uses broadcast services which include paging and FM subcarrier technology for transmitting data to subscribers over the paging and FM frequency channels. From Figure C.1-3b, the broadcast data is processed (in the message processor) and distributed to the selected paging or FM broadcast stations. Broadcast stations encode and modulate the data using paging or FM subcarrier modulation format, as described in Section 7.

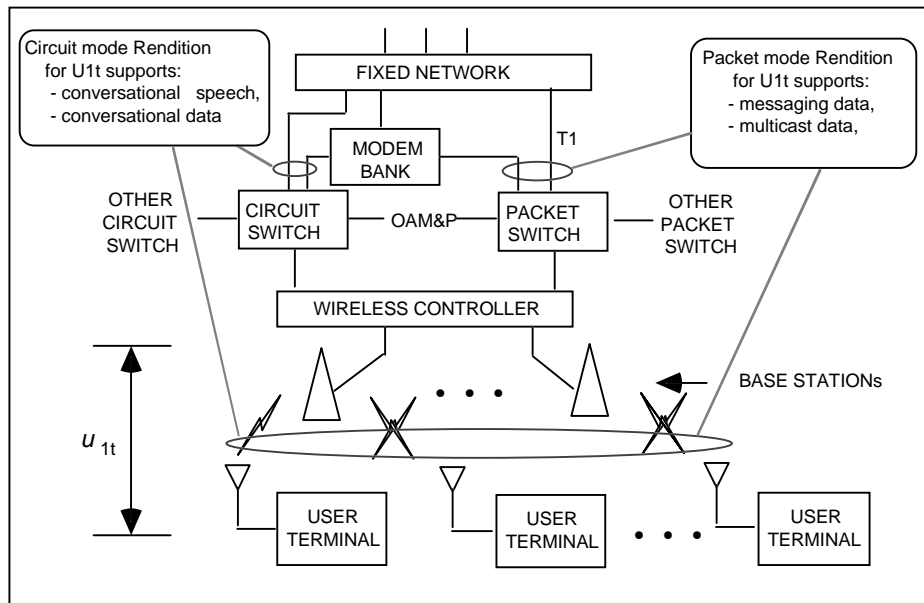


Figure C.1-3a Rendition 1 —  $u_{1t}$ , Two-Way Wide-Area Wireless Link

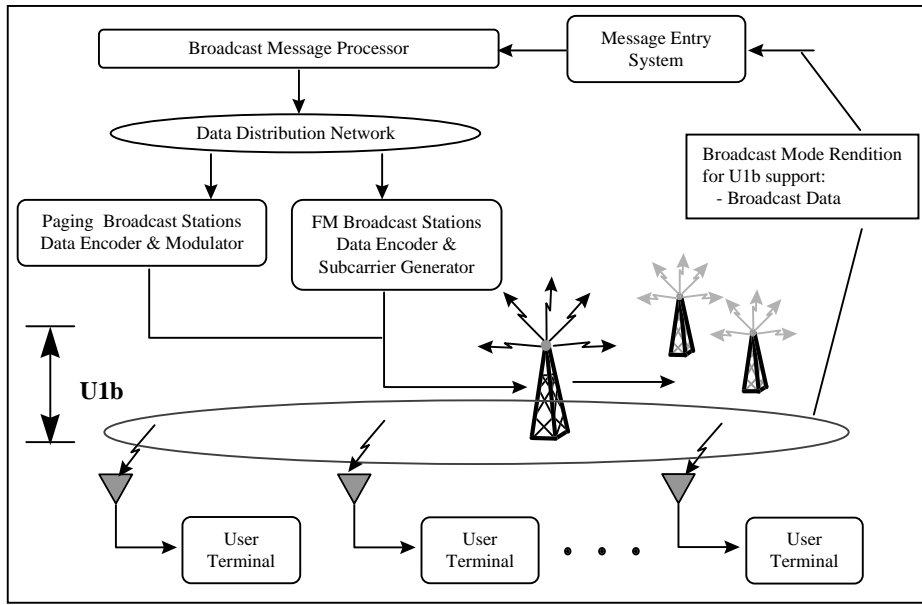


Figure C.1-3b Rendition 1 —  $u_{1b}$ , One-way Wide-Area Wireless Link

**Table C.1-1a Wireless Wide Area Data Flows (u<sub>1t</sub>)**

Flow #	Source	Source Name	Architecture Flow	Destination	Destination Name	Interconnects	Communication Service	Rationale
33	CVS	Commercial Vehicle Subsystem	driver and vehicle information	FMS	Fleet and Freight Management	U1t	messaging data, location data	bursty transactions
37	EM	Emergency Management	emergency dispatch requests	EVS	Emergency Vehicle Subsystem	U1t	Conversational speech, messaging data	Low delay bursty data or conversational speech
38	EM	Emergency Management	assigned route	EVS	Emergency Vehicle Subsystem	U1t	Conversational speech, messaging data	Low delay bursty data or conversational speech
39	EM	Emergency Management	Hazmat information	EVS	Emergency Vehicle Subsystem	U1t	Conversational speech, messaging data	Low delay bursty data or conversational speech
50	EM	Emergency Management	emergency acknowledge	VS	Vehicle	U1t	Conversational data conversational speec	Low delay bursty data
58	EVS	Emergency Vehicle Subsystem	emergency vehicle driver status update	EM	Emergency Management	U1t	messaging data	Low delay bursty data or live voice.
59	EVS	Emergency Vehicle Subsystem	emergency vehicle driver inputs	EM	Emergency Management	U1t	Conversational speech, messaging data	Bursty data or live voice. Minimum delay in data communication for forward and reverse link may be required
60	EVS	Emergency Vehicle Subsystem	emergency vehicle dispatch acknowledge	EM	Emergency Management	U1t	Conversational speech, messaging data	Bursty data or live voice. Minimum delay in data communication for forward and reverse link may be required
65	FMS	Fleet and Freight Management	fleet to driver update	CVS	Commercial Vehicle Subsystem	U1t	messaging data	Bursty data
91	ISP	Information Service Provider	trip plan	VS	Vehicle	U1t	Conversational data, Messaging data	Bursty data
92	ISP	Information Service Provider	traveler information	VS	Vehicle	U1t	messaging data, Broadcast data, Multicast	Bursty data
102	PIAS	Personal Information Access	emergency notification	EM	Emergency Management	U1t	Conversational data, messaging data, location data	Minimum delay in data communication for forward and reverse link maybe required. Location data for emergency response
107	PIAS	Personal Information Access	demand responsive transit request	TRMS	Transit Management	U1t	messaging data	Bursty messages
195	TRMS	Transit Management	emergency acknowledge	TRVS	Transit Vehicle Subsystem	U1t	Conversational data, messaging data	Minimum delay may be required
196	TRMS	Transit Management	driver instructions	TRVS	Transit Vehicle Subsystem	U1t	messaging data	
197	TRMS	Transit Management	bad tag list	TRVS	Transit Vehicle Subsystem	U1t	messaging data	Bursty data
199	TRMS	Transit Management	schedules, fare info request	TRVS	Transit Vehicle Subsystem	U1t	messaging data	Bursty data

**Table C.1-1a Wireless Wide Area Data Flows (u<sub>1t</sub>)**

Flow #	Source	Source Name	Architecture Flow	Destination	Destination Name	Interconnects	Communication Service	Rationale
200	TRMS	Transit Management	traveler information	TRVS	Transit Vehicle Subsystem	U1t	messaging data	Bursty data
210	TRVS	Transit Vehicle Subsystem	vehicle probe data	TRMS	Transit Management	U1t	Conversational data, messaging data, location data	Bursty data
211	TRVS	Transit Vehicle Subsystem	traveler information request	TRMS	Transit Management	U1t	Conversational data, messaging data	
212	TRVS	Transit Vehicle Subsystem	emergency notification	TRMS	Transit Management	U1t	messaging data	
217	VS	Vehicle	emergency notification	EM	Emergency Management	U1t	Conversational speech, messaging data, location data	Bursty data and live speech. Location data for emergency response
219	VS	Vehicle	traveler information request	ISP	Information Service Provider	U1t	Conversational data, messaging data	
220	VS	Vehicle	trip request	ISP	Information Service Provider	U1t	Conversational data, messaging data	Bursty data
221	VS	Vehicle	trip confirmation	ISP	Information Service Provider	U1t	Conversational data, messaging data	Bursty data
222	VS	Vehicle	vehicle probe data	ISP	Information Service Provider	U1t	messaging data, location data	Bursty data
223	VS	Vehicle	yellow pages request	ISP	Information Service Provider	U1t	Conversational data, messaging data	
230	VS	Vehicle	map update request	X23	Map Update Provider	U1t	messaging data	Bursty data
253	X23	Map Update Provider	map updates	VS	Vehicle	U1t	messaging data, Multicast data	Service on request or by subscription
34	CVS	Commercial Vehicle Subsystem	on board vehicle data	FMS	Fleet and Freight Management	U1t,U2	messaging data	Bursty transactions
198	TRMS	Transit Management	request for vehicle measures	TRVS	Transit Vehicle Subsystem	U1t,U2	Conversational data, messaging data	Bursty data using widearea wireless or short rang while passing by specific locations at speeds up to 70 mph
201	TRMS	Transit Management	route assignment	TRVS	Transit Vehicle Subsystem	U1t,U2	messaging data	Bursty data using widearea wireless or short rang while passing by specific locations at speeds up to 70 mph
209	TRVS	Transit Vehicle Subsystem	transit vehicle conditions	TRMS	Transit Management	U1t,U2	messaging data	Bursty data using widearea wireless or short rang while passing by specific locations at speeds up to 70 mph
213	TRVS	Transit Vehicle Subsystem	fare and payment status	TRMS	Transit Management	U1t,U2	Conversational data, messaging data	Bursty data using widearea wireless or short rang while passing

**Table C.1-1a Wireless Wide Area Data Flows (u<sub>1t</sub>)**

Flow #	Source	Source Name	Architecture Flow	Destination	Destination Name	Interconnects	Communication Service	Rationale
								by specific locations at speeds up to 70 mph
214	TRVS	Transit Vehicle Subsystem	transit vehicle passenger and use data	TRMS	Transit Management	U1t,U2	Conversational data, messaging data	Bursty data using widearea wireless or short rang while passing by specific locations at speeds up to 70 mph

**Table C.1-1b Wireless Wide Area Data Flows (u<sub>1b</sub>)**

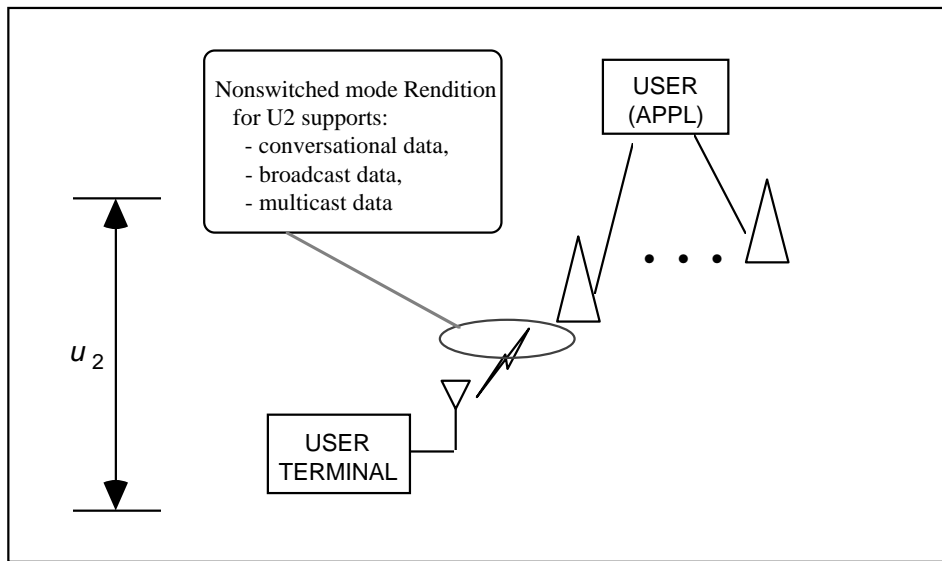
Flow #	Source	Source Name	Architecture Flow	Destination	Destination Name	Interconnects	Communication Service	Rationale
73	ISP	Information Service Provider	broadcast information	PIAS	Personal Information Access	W,U1b	messaging data,Broadcast data, Multicast	Free services & services that require subscription
80	ISP	Information Service Provider	broadcast information	RTS	Remote Traveler Support	U1b	messaging data,Broadcast data, Multicast	Free services and services that require subscription
90	ISP	Information Service Provider	broadcast information	VS	Vehicle	U1b	messaging data,Broadcast data, Multicast	Free services and services that require subscription
92	ISP	Information Service Provider	traveler information	VS	Vehicle	U1t, U1b	messaging data,Broadcast data, Multicast	Bursty data



**Rendition 2: ( $u_2$ )**

The  $u_2$  link is required to provide service between tetherless and close-proximity base stations, as occurs when a tetherless user communicates with a toll station for toll collection, a parking lot booth for fee collection, or the reception of information from roadside transmitters (roadside sign information). The primary use for this link is for rapid query-response interchanges and for local broadcast of information to nearby mobile users. The interchange must take place quickly as the vehicle will need the response for subsequent action, and the isolation of various users from jamming each other is based on range between user and base station, more than different frequencies. When the data flow is one directional, it is typically a broadcast function. As shown in Figure C.1-4, the  $u_2$  link provides wireless communication between the mobile user and the stationary user, or in the reverse direction. Because this user is local to the site of the communication, the messages pass only from user to transmitter to receiver to user.

This rendition supports the data flows listed in Table C.1-2.



**Figure C.1-4 Rendition 2 –  $u_2$  Close Proximity Mobile to Stationary User Link**

**Table C.1-2 Short Range (Close-Proximity Mobile-Fixed) Wireless Data Flows ( $u_2$ )**

Flow #	Source	Source Name	Architecture Flow	Destination	Destination Name	Interconnects	Communication Service	Rationale
34	CVS	Commercial Vehicle Subsystem	on board vehicle data	FMS	Fleet and Freight Management	U1t,U2	messaging data	Bursty transactions
198	TRMS	Transit Management	request for vehicle measures	TRVS	Transit Vehicle Subsystem	U1t,U2	Conversational data, messaging data	Bursty data using widearea wireless or short rang while passing by specific locations at speeds up to 70 mph
201	TRMS	Transit Management	route assignment	TRVS	Transit Vehicle Subsystem	U1t,U2	messaging data	Bursty data using widearea wireless or short rang while passing by specific locations at speeds up to 70 mph
209	TRVS	Transit Vehicle Subsystem	transit vehicle conditions	TRMS	Transit Management	U1t,U2	messaging data	Bursty data using widearea wireless or short rang while passing by specific locations at speeds up to 70 mph
213	TRVS	Transit Vehicle Subsystem	fare and payment status	TRMS	Transit Management	U1t,U2	Conversational data, messaging data	Bursty data using widearea wireless or short rang while passing by specific locations at speeds up to 70 mph
214	TRVS	Transit Vehicle Subsystem	transit vehicle passenger and use data	TRMS	Transit Management	U1t,U2	Conversational data, messaging data	Bursty data using widearea wireless or short rang while passing by specific locations at speeds up to 70 mph
21	CVCS	Commercial Vehicle Check	clearance event record	CVS	Commercial Vehicle Subsystem	U2	Conversational data	Short range communication, for moving vehicles when passing by specific locations at speeds up to 70 mph
22	CVCS	Commercial Vehicle Check	pass/pull-in	CVS	Commercial Vehicle Subsystem	U2	Conversational data	Short range communication, for moving vehicles when passing by specific locations at speeds up to 70 mph
23	CVCS	Commercial Vehicle Check	safety inspection record	CVS	Commercial Vehicle Subsystem	U2	Conversational Data	Short range communication, for moving vehicles when passing by specific locations at speeds up to 70 mph
24	CVCS	Commercial Vehicle Check	screening request	CVS	Commercial Vehicle Subsystem	U2	Conversational data	Short range communication, for moving vehicles when passing by specific locations at speeds up to 70 mph
25	CVCS	Commercial Vehicle	lock tag data request	CVS	Commercial Vehicle	U2	Conversational Data	

**Table C.1-2 Short Range (Close-Proximity Mobile-Fixed) Wireless Data Flows ( $u_2$ )**

Flow #	Source	Source Name	Architecture Flow	Destination	Destination Name	Interconnects	Communication Service	Rationale
		Check			Subsystem			
26	CVCS	Commercial Vehicle Check	border clearance request	CVS	Commercial Vehicle Subsystem	U2	Conversational data	Short range communication, for moving vehicles when passing by specific locations at speeds up to 70 mph
27	CVCS	Commercial Vehicle Check	on-board safety request	CVS	Commercial Vehicle Subsystem	U2	Conversational data	Short range communication, for moving vehicles when passing by specific locations at speeds up to 70 mph
28	CVCS	Commercial Vehicle Check	border clearance event record	CVS	Commercial Vehicle Subsystem	U2	Conversational Data	Short range communication, for moving vehicles when passing by specific locations at speeds up to 70 mph
29	CVS	Commercial Vehicle Subsystem	border clearance data	CVCS	Commercial Vehicle Check	U2	Conversational data	Short range communication, for moving vehicles when passing by specific locations at speeds up to 70 mph
30	CVS	Commercial Vehicle Subsystem	on board safety data	CVCS	Commercial Vehicle Check	U2	Conversational data	Short range communication, for moving vehicles when passing by specific locations at speeds up to 70 mph
31	CVS	Commercial Vehicle Subsystem	screening data	CVCS	Commercial Vehicle Check	U2	Conversational data	Short range communication, for moving vehicles when passing by specific locations at speeds up to 70 mph
32	CVS	Commercial Vehicle Subsystem	lock tag data	CVCS	Commercial Vehicle Check	U2	Conversational Data	
61	EVS	Emergency Vehicle Subsystem	emergency vehicle preemption request	RS	Roadway Subsystem	U2	Conversational data	Short range bursty data communication while in motion, when passing by specific locations at speeds up to 70 mph
115	PMS	Parking Management	request tag data	VS	Vehicle	U2	Conversational data	Data transfer while in motion, when passing the specific locations at speeds up to 70 mph
116	PMS	Parking Management	tag update	VS	Vehicle	U2	Conversational data	Data transfer while in motion, when passing the specific locations at speeds up to 70 mph
136	RS	Roadway Subsystem	AHS control data	VS	Vehicle	U2	messaging data	Data transfer while in motion, when passing the specific locations at

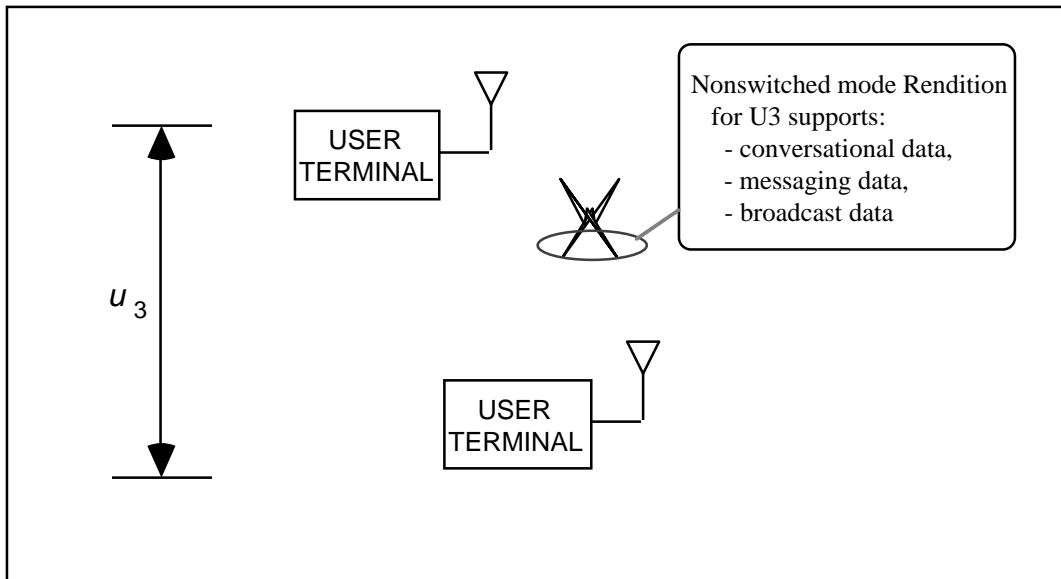
**Table C.1-2 Short Range (Close-Proximity Mobile-Fixed) Wireless Data Flows ( $u_2$ )**

Flow #	Source	Source Name	Architecture Flow	Destination	Destination Name	Interconnects	Communication Service	Rationale
								speeds up to 70 mph
137	RS	Roadway Subsystem	vehicle signage data	VS	Vehicle	U2	messaging data	Data transfer while in motion, when passing the specific locations at speeds up to 70 mph
138	RS	Roadway Subsystem	intersection status	VS	Vehicle	U2	messaging data	Data transfer while in motion, when passing the specific locations at speeds up to 70 mph
139	RS	Roadway Subsystem	request tag data	VS	Vehicle	U2	Messaging data	
161	TCS	Toll Collection	tag update	VS	Vehicle	U2	Conversational Data	Data communication while passing by specific locations at speeds up to 70 mph
162	TCS	Toll Collection	request tag data	VS	Vehicle	U2	Conversational data	Data communication while passing by specific locations at speeds up to 70 mph
208	TRVS	Transit Vehicle Subsystem	local signal priority request	RS	Roadway Subsystem	U2	Conversational data	Data communication while passing by specific locations at speeds up to 70 mph
224	VS	Vehicle	tag data	PMS	Parking Management	U2	Conversational data	Data communication while passing by specific locations at speeds up to 70 mph
225	VS	Vehicle	AHS vehicle data	RS	Roadway Subsystem	U2	Conversational data	Data communication while passing by specific locations at speeds up to 70 mph
226	VS	Vehicle	vehicle probe data	RS	Roadway Subsystem	U2	Messaging Data	Data communication while passing by specific locations at speeds up to 70 mph
227	VS	Vehicle	tag data	TCS	Toll Collection	U2	Conversational data	Data communication while passing by specific locations at speeds up to 70 mph
236	X10	CVO Inspector	CVC override mode	CVCS	Commercial Vehicle Check	U2	Conversational data, messaging data	

**Rendition 3: ( $u_3$ )**

The  $u_3$  link is required to provide communication between two (or more) tetherless users, as occurs in implementing the Automated Highway System (AHS). As shown in Figure C.1-5, the  $u_3$  link provides time critical mostly line-of-sight data communication between tetherless users. This is still an area of research and standards for this link are in their infancy. The typical data flows include:

	Source	Architecture Flow	Destination	Communication Service
180	VS	veh to veh cord	X34	Conversational data
207	X34	Speed and Headway	VS	Conversational data
208	X34	veh to veh cord	VS	Conversational data



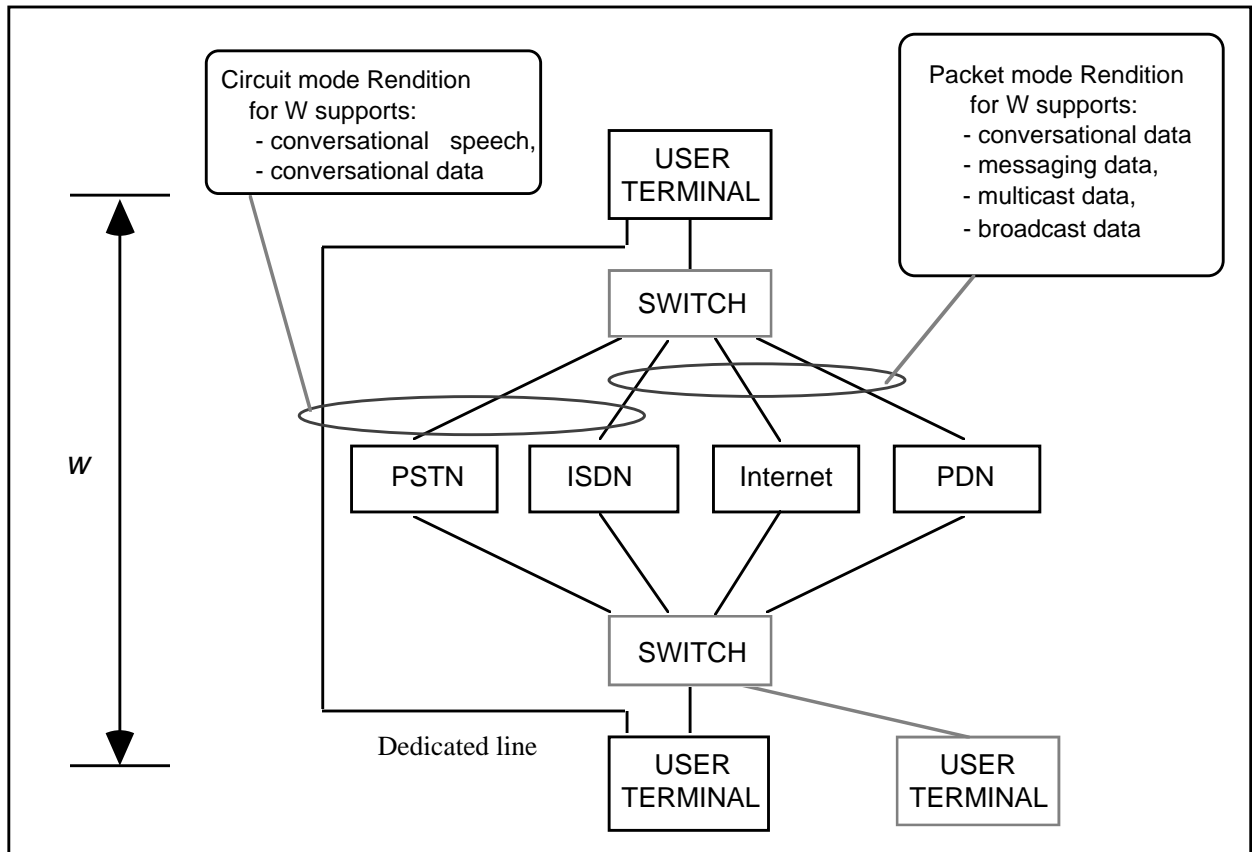
**Figure C.1-5 Rendition 3 –  $u_3$ , Close Proximity Vehicle-to-Vehicle Connection**

**Rendition 4: (*w*)**

The *w* link mostly makes use of existing public telecommunications services to provide communication between fixed users. When the fixed users are not local and usage rates are low, the normal telco connection is used, whereas for heavily loaded communications, a dedicated link may be installed or leased from the telco. As shown in Figure C.1-6, the *w* link provides connection from the user, either through an on-site switch (PBX) or directly (the dotted box indicates the switch may not be used) to the public service provider (Internet, PDN or ISDN, etc.), as in the case where access to the Internet was through a cable television service and the entire capacity was used for the single user terminal. The dedicated connection would usually only apply to heavy usage links.

Note that in the figure for the wireline connection, Rendition 4, digital transmission can make use of the dedicated line, between single users when high loading is usual, or between switches to spread its capacity among many users.

This rendition supports the data flows listed in Table C.1-3.



**Figure C.1-6. Rendition 4 – *w*, The Wireline Connection**

**Table C.1-3 Wireline Connection Data Flows (w)**

Flow #	Source	Source Name	Architecture Flow	Destination	Destination Name	Interconnects	Communication Service	Rationale
3	CVAS	Commercial Vehicle Administration	CVO database update	CVCS	Commercial Vehicle Check	W	Conversational data, messaging data	
4	CVAS	Commercial Vehicle Administration	international border crossing data	CVCS	Commercial Vehicle Check	W	messaging data	
6	CVAS	Commercial Vehicle Administration	compliance review report	FMS	Fleet and Freight Management	W	messaging data	
7	CVAS	Commercial Vehicle Administration	activity reports	FMS	Fleet and Freight Management	W	messaging data	
8	CVAS	Commercial Vehicle Administration	operational data	PS	Planning Subsystem	W	messaging data	
9	CVAS	Commercial Vehicle Administration	payment request	X21	Financial Institution	W	Conversational data, messaging data	
10	CVAS	Commercial Vehicle Administration	tax-credentials-fees request	X22	Government Administrators	W	messaging data	
11	CVAS	Commercial Vehicle Administration	credentials and safety information request	X59	Other CVAS	W	messaging data	
12	CVAS	Commercial Vehicle Administration	CVAS information exchange	X59	Other CVAS	W	messaging data	
13	CVAS	Commercial Vehicle Administration	violation notification	X62	Enforcement Agency	W	messaging data	
14	CVAS	Commercial Vehicle Administration	license request	X64	DMV	W	messaging data	
15	CVAS	Commercial Vehicle Administration	credentials and safety information response	X65	CVO Information Requestor	W	messaging data	
16	CVCS	Commercial Vehicle Check	credentials information request	CVAS	Commercial Vehicle Administration	W	Conversational data, messaging data	
17	CVCS	Commercial Vehicle Check	roadside log update	CVAS	Commercial Vehicle Administration	W	Messaging data	
18	CVCS	Commercial Vehicle Check	citation and accident data	CVAS	Commercial Vehicle Administration	W	Conversational data, messaging data	
19	CVCS	Commercial Vehicle Check	safety information request	CVAS	Commercial Vehicle Administration	W	Conversational data, messaging data	
20	CVCS	Commercial Vehicle Check	international border crossing data update	CVAS	Commercial Vehicle Administration	W	Conversational data, messaging data	
35	CVS	Commercial Vehicle Subsystem	processed cargo data	VS	Vehicle	W	messaging data	
36	CVS	Commercial Vehicle Subsystem	lock tag data request	X08	Commercial Vehicle	W	Conversational Data	

**Table C.1-3 Wireline Connection Data Flows (w)**

Flow #	Source	Source Name	Architecture Flow	Destination	Destination Name	Interconnects	Communication Service	Rationale
40	EM	Emergency Management	Hazmat information request	FMS	Fleet and Freight Management	W	Conversational data, messaging data	
41	EM	Emergency Management	emergency vehicle route request	ISP	Information Service Provider	W	Conversational speech, messaging data	
42	EM	Emergency Management	incident information	ISP	Information Service Provider	W	Conversational speech, messaging data	
44	EM	Emergency Management	operational data	PS	Planning Subsystem	W	Conversational data, messaging data	
46	EM	Emergency Management	incident information	TMS	Traffic Management	W	Conversational data, messaging data	
47	EM	Emergency Management	emergency vehicle greenwave request	TMS	Traffic Management	W	Conversational data conversational speech	
48	EM	Emergency Management	incident response status	TMS	Traffic Management	W	Conversational data, messaging data	
49	EM	Emergency Management	transit emergency coordination data	TRMS	Transit Management	W	Conversational data, messaging data	
51	EM	Emergency Management	emergency status	X13	E911 or ETS	W	Conversational data conversational speech	
52	EM	Emergency Management	map update request	X23	Map Update Provider	W	messaging data	
53	EM	Emergency Management	emergency coordination	X30	Other EM	W	Conversational data, messaging data	
54	EMMS	Emissions Management	operational data	PS	Planning Subsystem	W	messaging data	
55	EMMS	Emissions Management	vehicle pollution criteria	RS	Roadway Subsystem	W	messaging data	
56	EMMS	Emissions Management	widearea statistical pollution information	TMS	Traffic Management	W	messaging data	
57	EMMS	Emissions Management	map update request	X23	Map Update Provider	W	messaging data	
62	FMS	Fleet and Freight Management	tax filing, audit data	CVAS	Commercial Vehicle Administration	w	messaging data	
63	FMS	Fleet and Freight Management	credential application	CVAS	Commercial Vehicle Administration	W	Conversational data, messaging data	
64	FMS	Fleet and Freight Management	information request	CVAS	Commercial Vehicle Administration	W	Conversational data, messaging data	
66	FMS	Fleet and Freight Management	Hazmat information	EM	Emergency Management	W	Conversational data, messaging data	



**Table C.1-3 Wireline Connection Data Flows (w)**

Flow #	Source	Source Name	Architecture Flow	Destination	Destination Name	Interconnects	Communication Service	Rationale
67	FMS	Fleet and Freight Management	route request	ISP	Information Service Provider	W	Conversational data, messaging data	
68	FMS	Fleet and Freight Management	intermod CVO coord	X01	Intermodal Freight Shipper	W	messaging data	
69	FMS	Fleet and Freight Management	intermod CVO coord	X60	Intermodal Freight Depot	W	messaging data	
70	ISP	Information Service Provider	emergency vehicle route	EM	Emergency Management	W	Conversational speech, messaging data	
71	ISP	Information Service Provider	incident information request	EM	Emergency Management	W	Conversational speech, messaging data	
72	ISP	Information Service Provider	route plan	FMS	Fleet and Freight Management	W	messaging data	
76	ISP	Information Service Provider	parking lot data request	PMS	Parking Management	W	messaging data	
77	ISP	Information Service Provider	parking reservations request	PMS	Parking Management	W	messaging data	
78	ISP	Information Service Provider	road network use	PS	Planning Subsystem	W	messaging data	
79	ISP	Information Service Provider	traveler information	RTS	Remote Traveler Support	W	Broadcast data, Multicast data	
81	ISP	Information Service Provider	trip plan	RTS	Remote Traveler Support	W	Conversational Data	
82	ISP	Information Service Provider	request for toll schedules	TAS	Toll Administration	W	messaging data	
83	ISP	Information Service Provider	incident notification	TMS	Traffic Management	W	Conversational Data	
84	ISP	Information Service Provider	request for traffic information	TMS	Traffic Management	W	messaging data	
85	ISP	Information Service Provider	logged route plan	TMS	Traffic Management	W	Conversational data, Messaging data	
86	ISP	Information Service Provider	road network use	TMS	Traffic Management	W	messaging data	
87	ISP	Information Service Provider	transit information request	TRMS	Transit Management	W	messaging data	
88	ISP	Information Service Provider	selected routes	TRMS	Transit Management	W	Conversational data, Messaging data	
89	ISP	Information Service Provider	demand responsive transit request	TRMS	Transit Management	W	messaging data	

**Table C.1-3 Wireline Connection Data Flows (w)**

Flow #	Source	Source Name	Architecture Flow	Destination	Destination Name	Interconnects	Communication Service	Rationale
93	ISP	Information Service Provider	intermodal information	X02	Intermodal Transportation Service Provider	W	messaging data	
94	ISP	Information Service Provider	payment request	X21	Financial Institution	W	Conversational data, messaging data	
95	ISP	Information Service Provider	map update request	X23	Map Update Provider	W	messaging data	
96	ISP	Information Service Provider	travel service reservation	X24	Yellow Pages Service Providers	W	messaging data	
97	ISP	Information Service Provider	traffic information	X27	Media	W	messaging data	
98	ISP	Information Service Provider	incident information	X27	Media	W	messaging data	
99	ISP	Information Service Provider	traffic information	X28	Media Operator	W	messaging data, Broadcast data, Multicast	
100	ISP	Information Service Provider	incident information	X28	Media Operator	W	messaging data	
101	ISP	Information Service Provider	ISP coord	X31	Other ISP	W	messaging data	
109	PMS	Parking Management	parking lot reservation confirmation	ISP	Information Service Provider	W	messaging data	
110	PMS	Parking Management	parking availability	ISP	Information Service Provider	W	messaging data	
111	PMS	Parking Management	operational data	PS	Planning Subsystem	W	messaging data	
112	PMS	Parking Management	demand management price change response	TMS	Traffic Management	W	messaging data	
113	PMS	Parking Management	parking availability	TMS	Traffic Management	W	messaging data	
114	PMS	Parking Management	transit parking coordination	TRMS	Transit Management	W	Messaging data	
117	PMS	Parking Management	payment request	X21	Financial Institution	W	Conversational data, messaging data	
118	PMS	Parking Management	parking status	X36	Parking Operator	W	messaging data	
119	PMS	Parking Management	parking availability	X37	Parking Service Provider	W	messaging data	
120	PMS	Parking Management	violation notification	X62	Enforcement Agency	W	messaging data	
121	PMS	Parking Management	license request	X64	DMV	W	Messaging data	
122	PS	Planning Subsystem	planning data	TMS	Traffic Management	W	messaging data	

**Table C.1-3 Wireline Connection Data Flows (w)**

Flow #	Source	Source Name	Architecture Flow	Destination	Destination Name	Interconnects	Communication Service	Rationale
123	PS	Planning Subsystem	map update request	X23	Map Update Provider	W	Messaging data	
124	PS	Planning Subsystem	planning data	X25	Transportation Planners	W	messaging data	
125	RS	Roadway Subsystem	pollution data	EMMS	Emissions Management	W	messaging data	
126	RS	Roadway Subsystem	fault reports	TMS	Traffic Management	W	Conversational data, messaging data	
127	RS	Roadway Subsystem	request for right of way	TMS	Traffic Management	W	Conversational Data	
128	RS	Roadway Subsystem	vehicle probe data	TMS	Traffic Management	W	messaging data	
129	RS	Roadway Subsystem	AHS status	TMS	Traffic Management	W	messaging data	
130	RS	Roadway Subsystem	incident data	TMS	Traffic Management	W	messaging data	
131	RS	Roadway Subsystem	freeway control status	TMS	Traffic Management	w	messaging data	
132	RS	Roadway Subsystem	signal control status	TMS	Traffic Management	W	messaging data	
133	RS	Roadway Subsystem	HOV data	TMS	Traffic Management	W	Messaging data	
134	RS	Roadway Subsystem	signal priority request	TMS	Traffic Management	W	messaging data	
135	RS	Roadway Subsystem	local traffic flow	TMS	Traffic Management	W	messaging data	
140	RS	Roadway Subsystem	grant right of way and/or stop traffic	X29	Multimodal Crossings	W	Conversational data, messaging data	
142	RTS	Remote Traveler Support	yellow pages request	ISP	Information Service Provider	W	Conversational data, Messaging Data	
143	RTS	Remote Traveler Support	trip request	ISP	Information Service Provider	W	Conversational Data	
144	RTS	Remote Traveler Support	traveler information request	ISP	Information Service Provider	W	messaging data	
145	RTS	Remote Traveler Support	demand responsive transit request	ISP	Information Service Provider	W	messaging data	
146	RTS	Remote Traveler Support	emergency notification	TRMS	Transit Management	W	Conversational data, Messaging Data	
147	RTS	Remote Traveler Support	transit request	TRMS	Transit Management	W	messaging data	
148	RTS	Remote Traveler Support	traveler information request	TRMS	Transit Management	W	messaging data	
149	RTS	Remote Traveler Support	map update request	X23	Map Update Provider	W	messaging data	
150	TAS	Toll Administration	toll schedules	ISP	Information Service Provider	W	messaging data	
151	TAS	Toll Administration	operational data	PS	Planning Subsystem	W	messaging data	
152	TAS	Toll Administration	toll instructions	TCS	Toll Collection	W	messaging data	

**Table C.1-3 Wireline Connection Data Flows (w)**

Flow #	Source	Source Name	Architecture Flow	Destination	Destination Name	Interconnects	Communication Service	Rationale
153	TAS	Toll Administration	demand management price change response	TMS	Traffic Management	W	messaging data	
154	TAS	Toll Administration	probe data	TMS	Traffic Management	W	messaging data	
156	TAS	Toll Administration	payment request	X21	Financial Institution	W	messaging data	
157	TAS	Toll Administration	toll revenues and summary reports	X44	Toll Service Provider	W	messaging data	
158	TAS	Toll Administration	violation notification	X62	Enforcement Agency	W	messaging data	
159	TAS	Toll Administration	license request	X64	DMV	W	messaging data	
160	TCS	Toll Collection	toll transactions	TAS	Toll Administration	W	messaging data	
163	TMS	Traffic Management	incident information request	EM	Emergency Management	W	Messaging data	
164	TMS	Traffic Management	incident notification	EM	Emergency Management	W	Messaging data	
165	TMS	Traffic Management	pollution state data request	EMMS	Emissions Management	W	messaging data	
166	TMS	Traffic Management	traffic information	ISP	Information Service Provider	W	messaging data	
167	TMS	Traffic Management	parking instructions	PMS	Parking Management	W	messaging data	
168	TMS	Traffic Management	demand management price change request	PMS	Parking Management	W	messaging data	
169	TMS	Traffic Management	operational data	PS	Planning Subsystem	W	messaging data	
170	TMS	Traffic Management	freeway control data	RS	Roadway Subsystem	W	messaging data	
171	TMS	Traffic Management	signal control data	RS	Roadway Subsystem	W	messaging data	
172	TMS	Traffic Management	AHS control information	RS	Roadway Subsystem	W	messaging data	
173	TMS	Traffic Management	signage data	RS	Roadway Subsystem	W	messaging data	
174	TMS	Traffic Management	demand management price change request	TAS	Toll Administration	W	messaging data	
175	TMS	Traffic Management	traffic information	TRMS	Transit Management	W	messaging data	
176	TMS	Traffic Management	demand management price change request	TRMS	Transit Management	W	messaging data	
177	TMS	Traffic Management	signal priority status	TRMS	Transit Management	W	Conversational data, messaging data	
178	TMS	Traffic Management	event confirmation	X19	Event Promoters	W	messaging data	
179	TMS	Traffic Management	map update request	X23	Map Update Provider	W	messaging data	
180	TMS	Traffic Management	TMC coord.	X35	Other TM	W	messaging data	
181	TMS	Traffic Management	violation notification	X62	Enforcement Agency	W	messaging data	
182	TMS	Traffic Management	license request	X64	DMV	W	messaging data	

**Table C.1-3 Wireline Connection Data Flows (w)**

Flow #	Source	Source Name	Architecture Flow	Destination	Destination Name	Interconnects	Communication Service	Rationale
183	TRMS	Transit Management	security alarms	EM	Emergency Management	W	Conversational data, messaging data, location data	Location data for emergency response
184	TRMS	Transit Management	demand responsive transit plan	ISP	Information Service Provider	W	Conversational data, messaging data	
185	TRMS	Transit Management	transit and fare schedules	ISP	Information Service Provider	W	messaging data	
186	TRMS	Transit Management	transit request confirmation	ISP	Information Service Provider	W	messaging data	
188	TRMS	Transit Management	parking lot transit response	PMS	Parking Management	W	messaging data, Broadcast data, Multicast	
189	TRMS	Transit Management	operational data	PS	Planning Subsystem	W	messaging data	
190	TRMS	Transit Management	traveler information	RTS	Remote Traveler Support	W	messaging data, Multicast data	
191	TRMS	Transit Management	transit and fare schedules	RTS	Remote Traveler Support	W	messaging data, Multicast data	
192	TRMS	Transit Management	emergency acknowledge	RTS	Remote Traveler Support	W	Conversational data, messaging data	
193	TRMS	Transit Management	request for transit signal priority	TMS	Traffic Management	W	messaging data	
194	TRMS	Transit Management	demand management price change response	TMS	Traffic Management	W	messaging data	
202	TRMS	Transit Management	intermodal information	X02	Intermodal Transportation Service Provider	W	messaging data	
203	TRMS	Transit Management	payment request	X21	Financial Institution	W	Conversational data, messaging data	
204	TRMS	Transit Management	map update request	X23	Map Update Provider	W	messaging data	
205	TRMS	Transit Management	TRMS coord	X33	Other TRM	W	messaging data	
206	TRMS	Transit Management	camera control	X42	Secure Area Environment	W	Conversational data, messaging data	
207	TRMS	Transit Management	violation notification	X62	Enforcement Agency	W	messaging data	
215	TRVS	Transit Vehicle Subsystem	traveler advisory request	VS	Vehicle	W	Messaging data	
216	VS	Vehicle	cargo data request	CVS	Commercial Vehicle Subsystem	W	Messaging data	
218	VS	Vehicle	vehicle location	EVS	Emergency Vehicle	W	Broadcast data	

**Table C.1-3 Wireline Connection Data Flows (w)**

Flow #	Source	Source Name	Architecture Flow	Destination	Destination Name	Interconnects	Communication Service	Rationale
					Subsystem			
228	VS	Vehicle	vehicle location	TRVS	Transit Vehicle Subsystem	W	Broadcast data	
229	VS	Vehicle	vehicle control	X03	Basic Vehicle	W	Conversational Data	
231	X01	Intermodal Freight Shipper	intermod CVO coord	FMS	Fleet and Freight Management	W	messaging data	
232	X02	Intermodal Transportation Service Provider	intermodal information	ISP	Information Service Provider	W	messaging data	
233	X02	Intermodal Transportation Service Provider	intermodal information	TRMS	Transit Management	W	messaging data	
234	X03	Basic Vehicle	vehicle measures	VS	Vehicle	W	Broadcast data	
235	X08	Commercial Vehicle	vehicle measures	CVS	Commercial Vehicle Subsystem	W	Broadcast data	
237	X13	E911 or ETS	incident information	EM	Emergency Management	W	Conversational data, conversational spec, location data	Location data for emergency response
238	X19	Event Promoters	event plans	TMS	Traffic Management	W	messaging data, Multicast data	
239	X21	Financial Institution	transaction status	CVAS	Commercial Vehicle Administration	W	Conversational data, messaging data	
240	X21	Financial Institution	transaction status	ISP	Information Service Provider	W	Conversational data, messaging data	
241	X21	Financial Institution	transaction status	PMS	Parking Management	W	Conversational data, messaging data	
242	X21	Financial Institution	transaction status	TAS	Toll Administration	W	Conversational data, messaging data	
243	X21	Financial Institution	transaction status	TRMS	Transit Management	W	Conversational data, messaging data	
244	X22	Government Administrators	regulations	CVAS	Commercial Vehicle Administration	W	messaging data, Multicast data	
245	X23	Map Update Provider	map updates	EM	Emergency Management	W	messaging data, Multicast data	
246	X23	Map Update Provider	map updates	EMMS	Emissions Management	W	messaging data	
247	X23	Map Update Provider	map updates	ISP	Information Service Provider	W	messaging data, Multicast data	

**Table C.1-3 Wireline Connection Data Flows (w)**

Flow #	Source	Source Name	Architecture Flow	Destination	Destination Name	Interconnects	Communication Service	Rationale
249	X23	Map Update Provider	map updates	PS	Planning Subsystem	W	messaging data, Broadcast data, Multicast	
250	X23	Map Update Provider	map updates	RTS	Remote Traveler Support	W	messaging data	
251	X23	Map Update Provider	map updates	TMS	Traffic Management	W	messaging data, Multicast data	
252	X23	Map Update Provider	map updates	TRMS	Transit Management	W	messaging data, Multicast data	
254	X24	Yellow Pages Service Providers	travel service info	ISP	Information Service Provider	W	messaging data	
255	X25	Transportation Planners	planning data	PS	Planning Subsystem	W	messaging data	
256	X27	Media	external reports	ISP	Information Service Provider	W	messaging data, Multicast data	
257	X28	Media Operator	incident notification	ISP	Information Service Provider	W	messaging data, Broadcast data, Multicast	
258	X29	Multimodal Crossings	right of way preemption request	RS	Roadway Subsystem	W	Conversational data, messaging data	
259	X29	Multimodal Crossings	request for right of way	RS	Roadway Subsystem	W	Conversational data, messaging data	
260	X30	Other EM	emergency coordination	EM	Emergency Management	W	Conversational data, messaging data	
261	X31	Other ISP	ISP coord	ISP	Information Service Provider	W	messaging data	
262	X33	Other TRM	TRMS coord	TRMS	Transit Management	W	messaging data	
263	X35	Other TM	TMC coord.	TMS	Traffic Management	W	messaging data	
264	X37	Parking Service Provider	request for performance data	PMS	Parking Management	W	messaging data	
265	X51	Transit Vehicle	vehicle measures	TRVS	Transit Vehicle Subsystem	W	Broadcast data	
266	X58	Weather Service	weather information	ISP	Information Service Provider	W	messaging data, Broadcast data, Multicast	
267	X58	Weather Service	weather information	TMS	Traffic Management	W	messaging data, Broadcast data, Multicast	

**Table C.1-3 Wireline Connection Data Flows (w)**

Flow #	Source	Source Name	Architecture Flow	Destination	Destination Name	Interconnects	Communication Service	Rationale
268	X59	Other CVAS	CVAS information exchange	CVAS	Commercial Vehicle Administration	W	messaging data	
269	X59	Other CVAS	credentials and safety information response	CVAS	Commercial Vehicle Administration	W	messaging data	
270	X60	Intermodal Freight Depot	intermod CVO coord	FMS	Fleet and Freight Management	W	messaging data	
271	X64	DMV	registration	CVAS	Commercial Vehicle Administration	W	messaging data	
272	X64	DMV	vehicle characteristics	PMS	Parking Management	W	Messaging data	
273	X64	DMV	registration	TAS	Toll Administration	W	messaging data	
274	X64	DMV	registration	TMS	Traffic Management	W	messaging data	
275	X65	CVO Information Requestor	credentials and safety information request	CVAS	Commercial Vehicle Administration	W	messaging data	
73	ISP	Information Service Provider	broadcast information	PIAS	Personal Information Access	W,U1b	messaging data, Broadcast data, Multicast	Free services & services that require subscription
1	CVAS	Commercial Vehicle Administration	credentials information	CVCS	Commercial Vehicle Check	W,U1t	Conversational data, messaging data	The CVAS could be a transportable entity. Some transactions may need real time support
2	CVAS	Commercial Vehicle Administration	safety information	CVCS	Commercial Vehicle Check	W,U1t	Conversational data, messaging data	
5	CVAS	Commercial Vehicle Administration	electronic credentials	FMS	Fleet and Freight Management	W,U1t	messaging data	The CVAS could be a transportable entity.
43	EM	Emergency Management	emergency acknowledge	PIAS	Personal Information Access	W,U1t	Conversational data, messaging data	Wide area communication to PDA
45	EM	Emergency Management	emergency acknowledge	RTS	Remote Traveler Support	W,U1t	Conversational speech, messaging data	Wide area wireless communication to transportable units
74	ISP	Information Service Provider	trip plan	PIAS	Personal Information Access	W,U1t	Conversational data, Messaging data	Bursty data
75	ISP	Information Service Provider	traveler information	PIAS	Personal Information Access	W,U1t	Broadcast data, Multicast data	Bursty data upon request. Bursty or continuous transmission for one-way systems. Free services and services that require subscription.
103	PIAS	Personal Information	traveler information	ISP	Information Service	W,U1t	messaging data	Bursty messages, Wireless



**Table C.1-3 Wireline Connection Data Flows (w)**

Flow #	Source	Source Name	Architecture Flow	Destination	Destination Name	Interconnects	Communication Service	Rationale
		Access	request		Provider			to PDA. Location data for value added services.
104	PIAS	Personal Information Access	trip request	ISP	Information Service Provider	W,U1t	Conversational Data, Messaging data	Bursty messages, Wireless to PDA
105	PIAS	Personal Information Access	trip confirmation	ISP	Information Service Provider	W,U1t	Conversational Data, Messaging data	Bursty messages. Wireless to PDA
106	PIAS	Personal Information Access	yellow pages request	ISP	Information Service Provider	W,U1t	Conversational Data, Messaging data	Bursty messages, Wireless to PDA
108	PIAS	Personal Information Access	map update request	X23	Map Update Provider	W,U1t	messaging data	Service on request or services by subscription
141	RTS	Remote Traveler Support	emergency notification	EM	Emergency Management	W,U1t	Conversational speech, messaging data, location data	RTS can be a transportable unit. Location data emergency response.
187	TRMS	Transit Management	demand responsive transit route	PIAS	Personal Information Access	W,U1t	messaging data	Bursty data
248	X23	Map Update Provider	map updates	PIAS	Personal Information Access	W,U1t	messaging data, Multicast data	Service on request or by subscription

## C.2 Applicable Technologies Mapped to the Renditions

The task here is to identify applicable technologies which will support the Level 0 Rendition. This requires assessing the technologies presented in Appendix D, and then mapping them onto the Rendition Level 0 diagram as shown in Figure C.2-1. Evaluation of these technologies yields the Architecture Interconnect Specifications. A host of existing and emerging technologies applicable to ITS are identified in Appendix D. This assessment covers the candidate communication technologies depicted in Figure C.2-1.

The wireline technologies are typically provided by the local Telco and other service providers, although private networks are sometimes used when the loading is high enough to justify the cost. Even then, lines are often leased from the local Telco. The choice between the different services (PSTN, ISDN, IP, PDN) will be based almost exclusively on cost. As the competition to provide these services continues, it will be easy to switch from one to the other as the data transmission loads change and new services are offered.

As an illustrative example, a set of communication technologies that are applicable to provide some or all of the services identified in the AIDs for the  $u_{1t}$  link are listed in the highlighted box in Figure C.2-2. This figure shows the list of technologies superimposed on the  $u_{1t}$  Level 1 rendition.

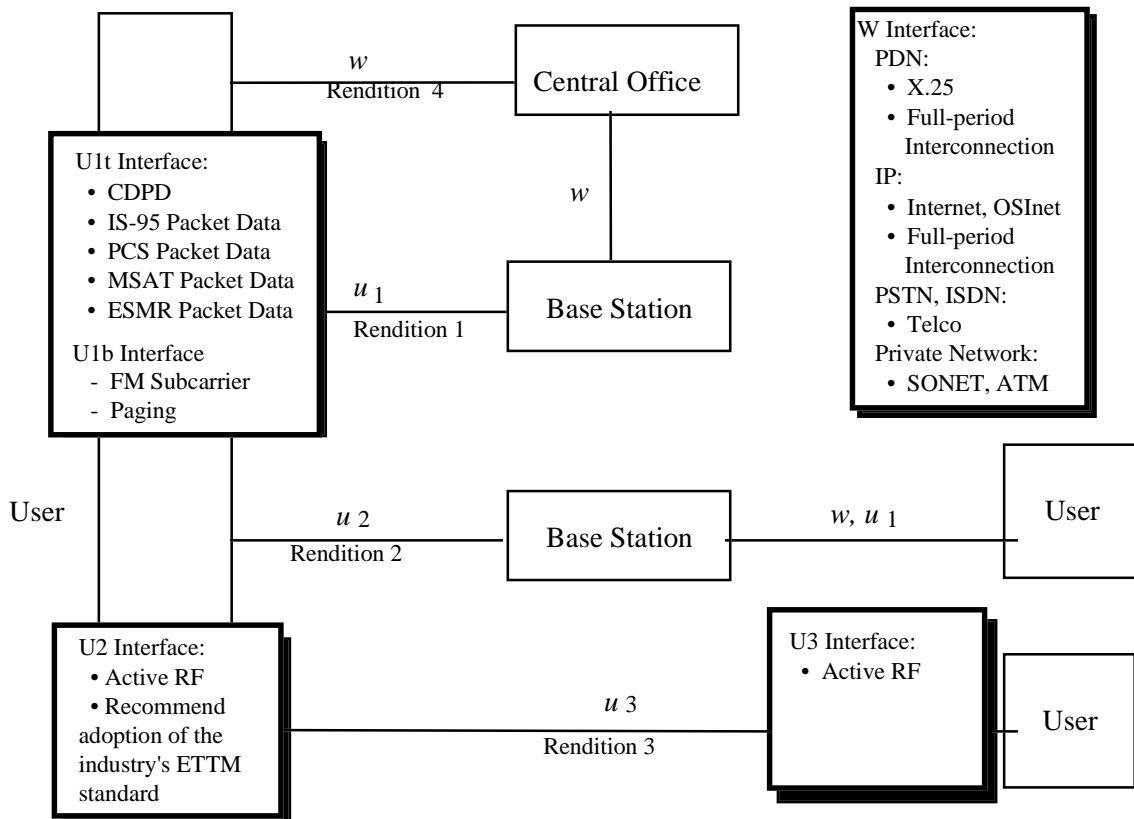


Figure C.2-1 Technology Mapping onto Level 0 Rendition

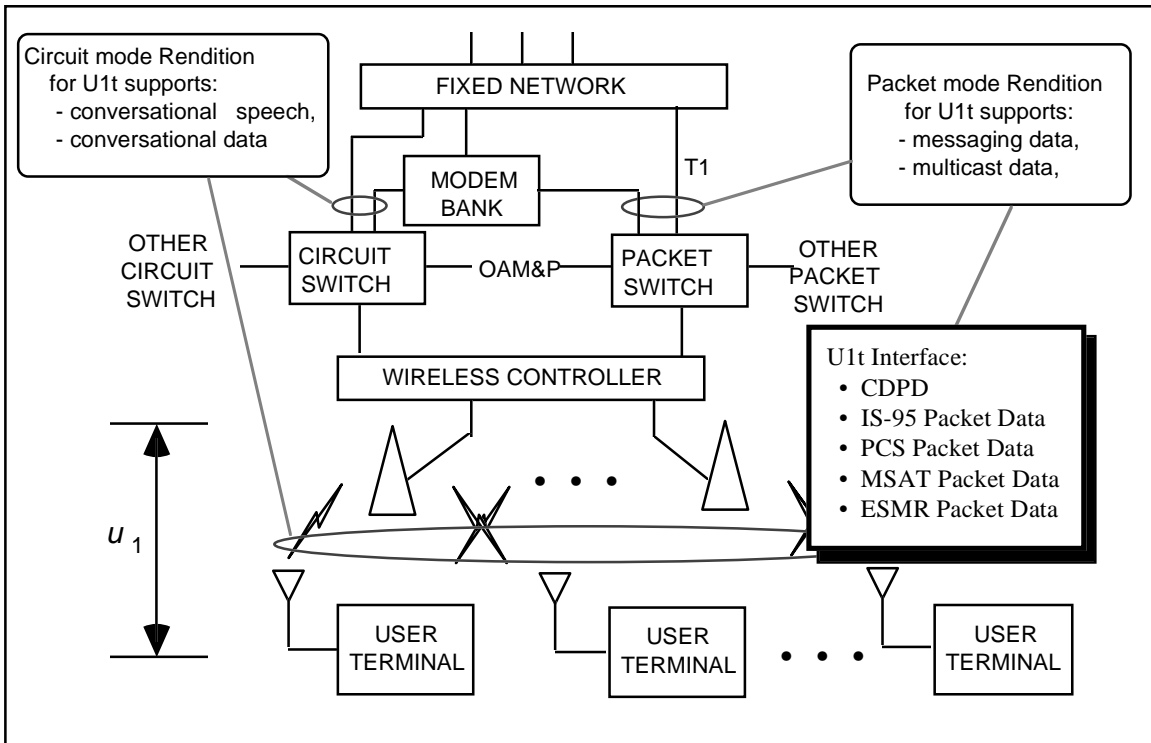


Figure C.2-2 Candidate Technologies for Rendition Level 1 – Two-Way Wide Area Wireless Link

## APPENDIX D TECHNOLOGY ASSESSMENT SOURCES

This appendix provides a list of technical sources and the URL's of web sites that were used to obtain information on the systems evaluated in Section 7.5. This information is intended to facilitate more in-depth study of the systems and to provide up-to-date technical, availability, and price information. Whenever possible, information for direct contact with the companies involved will also be provided. As a general rule, ITS America's World Wide Web site, <http://www.itsa.org/>, is a major source of information, however it is restricted to ITS America membership.

### D.1 Wireless

Wireless has seen in recent times an explosion of new books, making it almost impossible to track the wealth of information now available. As a compromise, reference will be made only to those works that endure the test of time, though still providing enough timely information to be useful.

#### D.1.1 MAN's

Due to their proprietary nature, there is little existing information on MAN's, especially on those using the ISM band. Therefore, only WWW references can be provided at this time.

Company	URL
Metricom, Inc. 980 University Avenue Los Gatos, CA 95030 (408) 399-8200	<a href="http://www.metricom.com/metricom.html">http://www.metricom.com/metricom.html</a>
Tetherless Access Ltd. 930 E. Arques Ave. Sunnyvale CA 94086 (408) 523-8000	<a href="http://www.tetherless.net/home.html">http://www.tetherless.net/home.html</a>

## D.1.2 Land Mobile Systems

### General Sources:

1. *Wireless Information Networks*, K. Pahlavan, A. Levesque, John Wiley & Sons, 1995
2. *Wireless Data Networking*, N.J. Muller, Artech House, 1995
3. *Wireless Personal Communications - The Future of Talk*, R. Schneiderman, IEEE Press, 1994
4. *Cellular Radio Systems*, D.M. Balston, R.C.V. Macario, Eds., Artech House, 1993
5. *Mobile Information Systems*, J. Walker, Ed., Artech House, 1990

### GSM Sources:

1. *The GSM System for Mobile Communications*, M. Mouly, M.-B. Pautet, self-published, 1992
2. *An Introduction to GSM*, S.M. Redl, M.K. Weber, M.W. Oliphant, Artech House, 1995
3. *Mobile Radio Communications*, R. Steele, Ed., Pentech Press Publishers, London, 1992

### WWW sites and contacts:

Company	URL
Omnipoint Corporation 1365 Garden of the Gods Road Colorado Springs, CO 80907 (719) 548-1200	<a href="http://www.omnipoint.com/">http://www.omnipoint.com/</a>
Northern Telecom Ltd.	<a href="http://www.nortel.com/english/wireless/omnipnt.html">http://www.nortel.com/english/wireless/omnipnt.html</a>
RAM Mobile Data Woodbridge, NJ 908-602-5500	<a href="http://www.ram-wireless.com/">http://www.ram-wireless.com/</a>
BellSouth Mobile Data, Inc. 1100 Peachtree Street, NE, Room 5D09 Atlanta, GA 30309-4599 (404) 249-4744	<a href="http://www.data-mobile.com/">http://www.data-mobile.com/</a>
Ericsson Mobile Communications AB	Mobitex  <a href="http://www.ericsson.com/mobitex/">http://www.ericsson.com/mobitex/</a> <a href="http://www.ericson.nl/EPI/BR/2mobitex.html">http://www.ericson.nl/EPI/BR/2mobitex.html</a>  D-AMPS 1900 <a href="http://www.ericsson.com/systems/D-AMPS_1900/">http://www.ericsson.com/systems/D-AMPS_1900/</a>
ARDIS Lincolnshire, IL 708-913-1215	<a href="http://www.ardis.com/ardis_hp/website2.htm">http://www.ardis.com/ardis_hp/website2.htm</a>
IBM Wireless 700 Park Office Road, Highway 54 Building 662 Research Triangle Park, NC 27709 (919) 543-7708	<a href="http://www.raleigh.ibm.com/cel/celinfo.html">http://www.raleigh.ibm.com/cel/celinfo.html</a>
Nextel Communications Inc. Rutherford, NJ	
Geotek Communications Inc. 20 Craig Road, Montvale, NJ 07645 (201) 930-9305	<a href="http://www.geotek.com/">http://www.geotek.com/</a>
SkyTel Corp.	<a href="http://www.skytel.com/">http://www.skytel.com/</a> <a href="http://www.skytel.com/Products/2way/">http://www.skytel.com/Products/2way/</a>

Motorola	<a href="http://www.mot.com/MIMS/WDG/">http://www.mot.com/MIMS/WDG/</a> <a href="http://www.mot.com/MIMS/PPG/org/amg/products/tango/">http://www.mot.com/MIMS/PPG/org/amg/products/tango/</a>
QUALCOMM Incorporated 6455 Lusk Boulevard San Diego, CA 92121-2779 (619) 587-1121	<a href="http://www.qualcomm.com/QualHome.html/">http://www.qualcomm.com/QualHome.html/</a>

#### CDPD Sources:

Company	URL
IBM Corp. Wireless Headquarters	<a href="http://www.raleigh.ibm.com/cel/celinfo.html">http://www.raleigh.ibm.com/cel/celinfo.html</a>
AT&T Wireless Services	<a href="http://www.airdata.com/index.html">http://www.airdata.com/index.html</a>
CDPD Forum Inc.	<a href="http://www.cdpd.org/">http://www.cdpd.org/</a>
Northern Telecom Ltd.	<a href="http://www.nortel.com/english/wireless/cdpd_net.html">http://www.nortel.com/english/wireless/cdpd_net.html</a>
Pacific Communication Sciences Inc.	<a href="http://www.pcsi.com/html/pr_cdpd.html">http://www.pcsi.com/html/pr_cdpd.html</a>
Tellabs Wireless Inc.	<a href="http://steinbrecher.com/architecture.html">http://steinbrecher.com/architecture.html</a> <a href="http://steinbrecher.com/compare.html">http://steinbrecher.com/compare.html</a>
Rockwell International Corp.	<a href="http://www.nb.rockwell.com/pb/cdpd.html">http://www.nb.rockwell.com/pb/cdpd.html</a> <a href="http://www.nb.rockwell.com/wcd/wireless.html">http://www.nb.rockwell.com/wcd/wireless.html</a>
Sierra Wireless Inc.	<a href="http://www.sierrawireless.ca/products.htm">http://www.sierrawireless.ca/products.htm</a>
Cincinnati Microwave	<a href="http://www.cnmw.com/">http://www.cnmw.com/</a> <a href="http://www.cnmw.com/product/cdpd/cdpdhtm.htm">http://www.cnmw.com/product/cdpd/cdpdhtm.htm</a>
Motorola	<a href="http://www.mot.com/MIMS/WDG/Technology/CelTAC/">http://www.mot.com/MIMS/WDG/Technology/CelTAC/</a>

#### CDPD Service Providers

Company	Service Name	Deployed
Ameritech Cellular Services Hoffman Estates, IL 708-248-2000	Wireless Packet Service	Chicago, Detroit/Ann Arbor, Gary,IN, Cincinnati, Columbus,OH, Milwaukee Data
Bell Atlantic Mobile Corp. Bedminster, NJ 908-306-7000	Airbridge Packet Service	Charlotte, NC; New London,CT; Northern New Jersey; Philadelphia; Phoenix; Pittsburgh; Washington,DC/ Baltimore; Hartford, CT
Comcast Cellular Communications Inc. Wayne, PA 610-995-5000		Philadelphia; Delaware; New Jersey
GTE Mobilnet Atlanta, GA 404-391-8000	CDPD Service	Houston, San Francisco, San Jose/ Oakland, Cleveland, Indianapolis, Memphis, Nashville, Tampa/ St. Petersburg
AT&T Wireless (ex-McCaw Cellular Communications Inc.) Kirkland, WA 206-803-4000	Airdata	Dallas, Las Vegas, Miami, New York, Seattle, Denver, Jacksonville, Orlando, Tampa/ St. Petersburg, West Palm Beach, Kansas City, Minneapolis, Oklahoma City, Pittsburgh, Portland, OR, Sacramento, Salt Lake City, San Antonio, San Jose
Nynex Mobile Communications Co. Orangeburg, NY 914-365-7200		Boston; New York
Sprint Cellular Co. Chicago 312-399-2275		New Mexico; Las Vegas, Greensboro/Winston-Salem, Norfolk

## GSM/PCS 1900 Sources, and Service Providers

Company	URL
VODAFONE	<a href="http://www.vodafone.co.uk/n3/index/indhome">http://www.vodafone.co.uk/n3/index/indhome</a>
Northern Telecom Ltd.	<a href="http://www.nortel.com/english/wireless/pcs_1900.html">http://www.nortel.com/english/wireless/pcs_1900.html</a>
Sprint Spectrum L.P.	<a href="http://www.sprint.com/home/product/spectrum.html">http://www.sprint.com/home/product/spectrum.html</a>

### D.1.3 Satellite Mobile Systems

In compiling the information on Satellite systems, two major sources were used:

1. *Satellite Communication Systems - Mobile and Fixed Services*, M.J. Miller, B. Vucetic, L. Berry, Eds., Kluwer Academic Publs., 1993
2. *Digital Satellite Communications Systems and Technologies - Military and Civil Applications*, A.N. Ince, Ed., Kluwer Academic Publs., 1992

In addition, extensive use was made of the WWW to track the most recent information on the proposed systems and to obtain the graphics relating to the systems' characteristics, mainly their orbits and coverage.

Company	URL
Iridium	<a href="http://leonardo.jpl.nasa.gov/msl/QuickLooks/iridiumQL.html">http://leonardo.jpl.nasa.gov/msl/QuickLooks/iridiumQL.html</a>
Teledesic	<a href="http://leonardo.jpl.nasa.gov/msl/QuickLooks/teledesicQL.html">http://leonardo.jpl.nasa.gov/msl/QuickLooks/teledesicQL.html</a>
Odyssey	<a href="http://leonardo.jpl.nasa.gov/msl/QuickLooks/odysseyQL.html">http://leonardo.jpl.nasa.gov/msl/QuickLooks/odysseyQL.html</a>
ICO Global Communications	<a href="http://www.i-co.co.uk/index-page.html">http://www.i-co.co.uk/index-page.html</a>
Orbcomm	<a href="http://leonardo.jpl.nasa.gov/msl/QuickLooks/orbcommQL.html">http://leonardo.jpl.nasa.gov/msl/QuickLooks/orbcommQL.html</a>
Skycell	<a href="http://www.azstarnet.com/public/commerce/satellite/">http://www.azstarnet.com/public/commerce/satellite/</a>
MSAT	<a href="http://www.radiosat.com/radiostar/msat.htm">http://www.radiosat.com/radiostar/msat.htm</a>
OmniTRACS	<a href="http://www.qualcomm.com/ProdTech/Omni/">http://www.qualcomm.com/ProdTech/Omni/</a>
INMARSAT	<a href="http://www.inmarsat.org/inmarsat/">http://www.inmarsat.org/inmarsat/</a>
COMSAT	<a href="http://www.comsat.com/">http://www.comsat.com/</a>
GPS	<a href="http://leonardo.jpl.nasa.gov/msl/Programs/gps.html">http://leonardo.jpl.nasa.gov/msl/Programs/gps.html</a>
DGPS	<a href="http://www.inforamp.net/~pinpoint/">http://www.inforamp.net/~pinpoint/</a>
Differential Corrections Inc. 10121 Miller Ave Cupertino, CA 95014 408-446-8350	<a href="http://www.dgps.com/">http://www.dgps.com/</a>
Omnistar, Inc. 8200 Westglen Houston, TX 77063 713-785-5850	<a href="http://www.omnistar.com/">http://www.omnistar.com/</a>
Glonass	<a href="http://leonardo.jpl.nasa.gov/msl/QuickLooks/glonassQL.html">http://leonardo.jpl.nasa.gov/msl/QuickLooks/glonassQL.html</a>
Mike's Spacecraft Library (@ JPL)	<a href="http://leonardo.jpl.nasa.gov/msl/home.html">http://leonardo.jpl.nasa.gov/msl/home.html</a>

#### D.1.4 Meteor Burst Systems

Main sources:

1. *Meteor Burst Communications - Theory and Practice*, D.L. Schilling, Ed., John Wiley & Sons, 1993
2. *Meteor Burst Communications*, J.Z. Schanker, Artech House, 1990

#### D.1.5 Broadcast Systems

An interesting article appeared recently in the IEEE Spectrum Magazine, covering most aspects of digital broadcasting:

1. "Broadcasting with Digital Audio", Robert Braham, Ed., IEEE Spectrum, March 1996

##### D.1.5.1 FM Subcarrier

Similar pages exist for other cities in the country:

City	URL
San Diego, CA	<a href="http://www.scubed.com/caltrans/sd/big_map.shtml">http://www.scubed.com/caltrans/sd/big_map.shtml</a>
Los Angeles, CA	<a href="http://www.scubed.com/caltrans/la/la_big_map.shtml">http://www.scubed.com/caltrans/la/la_big_map.shtml</a>
Seattle, WA	<a href="http://www.wsdot.wa.gov/regions/northwest/NWFLOW/">http://www.wsdot.wa.gov/regions/northwest/NWFLOW/</a>
Houston, TX	<a href="http://herman.tamu.edu/traffic.html">http://herman.tamu.edu/traffic.html</a>
Chicago, IL	<a href="http://www.ai.eecs.uic.edu/GCM/CongestionMap.html">http://www.ai.eecs.uic.edu/GCM/CongestionMap.html</a>

##### D.1.5.2 DAB

Company	URL
EuroDAB Newsletter	<a href="http://www.ebu.ch/dep_tech/eurodab.html">http://www.ebu.ch/dep_tech/eurodab.html</a>
Digital Radio Research Inc. (DRRI)	<a href="http://radioworks.cbc.ca/radio/digital-radio/drri.html">http://radioworks.cbc.ca/radio/digital-radio/drri.html</a>
USA Digital Radio	<a href="http://www.usadr.com/techieam.html">http://www.usadr.com/techieam.html</a>

#### D.1.6 Short-Range Communications

ITS America's World Wide Web site, <http://www.itsa.org/> is the main source of short-range communications information, since it maintains a data base of all related information.

##### D.1.6.1 DSRC Communications

Company	Home Page
Hughes	<a href="http://www.hughes.com/">http://www.hughes.com/</a>



### **D.1.6.2 Vehicle-to-Vehicle Communications**

AHS is still quite a new area, and information of interest can be found almost exclusively in trade magazines and in academic publications. A good example of the latter is the *IVHS Journal*, now *ITS Journal*, where a few papers have focused on this issue.

### **D.2 Wireline Communications**

Sources in this area abound. Here are just a few ones that we think are more appropriate given their emphasis on performance:

1. *Advances in Telecommunications Networks*, W.S. Lee, D.C. Brown, Artech House, 1995
2. *FDDI and FDDI-II: Architecture, Protocols, and Performance*, B. Albert, A.P. Jayasumana, Artech House, 1994
3. *SMDS: Wide-Area Data Networking with Switched Multi-megabit Data Service*, R.W. Klessig, K. Tesink, Prentice-Hall, 1995
4. *Asynchronous Transfer Mode Networks: Performance Issues*, R.O. Onvural, Artech House, 1994

As for service contacts, all RBOC's and major telecommunication companies offer wireline services of all kinds.

## **APPENDIX E POTENTIAL USERS ACCORDING TO USER SERVICE GROUP**

In order to enhance the understanding of the data loads generated by ITS services, the analyses were performed for seven distinct user service groups, each with its own population, message set, peak period definition, and message frequency of use. The user service groups include private vehicles, CVO-Local vehicles, CVO-long haul vehicles, travelers (PIAS users), transit management, emergency management, and probes.

The number of potential users that might buy a service was determined for each of the nine scenarios through the use of national statistics. The analysis used in the derivation is shown below, using the 1997 Urbansville scenario as an example. The same derivation was used for each of the other eight scenarios, working from the total population and number of household vehicles of the scenario region in that time frame. The theory is that the number of vehicles of all types can be related to the population, as long as the scenario regions all have the same services available. The lack of a particular service (e.g. fixed route transit in the rural scenario) was handled later in the data loading models with the lack of an entry in the database table of market packages of services for that scenario, preventing messages related to that service from being included in the message set for that scenario.

In the case of the Thruville scenario, the added traffic traveling completely through the entire scenario region must be added to the models shown here. This was accomplished by increasing the number of private vehicles and CVO long haul vehicles shown here by one-third. The other user service groups do not travel through the scenario region by definition.

The number of potential users was derived for the peak period defined for that particular user service group. The number of potential users for the off-peak period was then defined as a fraction of the peak period number.

## E.1 Private Vehicle Service Group Users – Urbansville, 1997

The peak period for this user service group is defined as the two, three-hour periods of 6 am to 9 am, and 4 PM to 7 PM. This two-peak model may not be very pronounced over the traffic which occurs between the peaks in many urban areas, but the peaks are present. The number of household vehicles in the Urbansville region is defined in the Urbansville Scenario Guide for the five-year time frame as 1,688,970<sup>1</sup>. The average daily number of miles driven per household vehicle in the Urbansville region was derived from the average number of household vehicle miles traveled per year in the US ( $1.4096 \times 10^{12}$ )<sup>2</sup> divided by the total number of household vehicles in the US ( $1.6522 \times 10^8$ )<sup>3</sup>. This result (8531.6 miles per year) is divided by 365 to obtain the average household vehicle miles traveled per day (23.374). There is little error in the assumption that the miles driven are equal for every day of the week. The distribution of person trips by day of the week shows little variation between week days and weekend days<sup>4</sup>. The daily household vehicle miles traveled (23.374) is multiplied by the number of household vehicles in the Urbansville region (1,688,970) to obtain the Daily Vehicles Miles Traveled (DVMT) for Urbansville.

$$\text{DVMT} = 39,478,000 \text{ miles}$$

Since we are principally interested in the peak period traffic, we must then obtain the DVMT in the peak period, consisting of the two, three-hour periods. The fraction of traffic found in one study to consistently occur during the peak periods was 45%<sup>5</sup>. The number of weekday trips in the peak periods was found by survey to be 41.3% of the daily trips<sup>6</sup>. A CALTRANS study found that the traffic counts during the peak periods were 37.6% of the daily traffic on their freeway system<sup>7</sup>. Using an rounded up average fraction of 42%, and multiplying DVMT by that peak-period fraction (0.42), results in the peak-period DVMT (PDVMT):

$$\text{PDVMT} = 16,700,000 \text{ miles}$$

Dividing PDVMT by the average trip length during the peak period will result in the number of trips during the peak period. The trip length used is 11 miles<sup>8</sup>. Since 95% of the household travel

---

<sup>1</sup> Urban Scenario Guide, Urbansville, Phase II, March 13, 1995.

<sup>2</sup> Summary of Travel Trends, 1990 National Personal Transportation Survey, Center for Transportation Analysis, Energy Division, Oak Ridge National Laboratory, Oak Ridge TN, 1993, page 6.

<sup>3</sup> Summary of Travel Trends, 1990 National Personal Transportation Survey, Center for Transportation Analysis, Energy Division, Oak Ridge National Laboratory, Oak Ridge TN, 1993, page 6.

<sup>4</sup> NPTS Databook, National Personal Transportation Survey, Volume I, Center for Transportation Analysis, Energy Division, Oak Ridge National Laboratory, Oak Ridge TN, 1993, page 4-103.

<sup>5</sup> Hanks, J. W., and T. J. Lomax, Roadway Congestion in Major Urban Areas 1982 to 1988, Texas Transportation Institute, College Station, Texas, 1990, page D-5.

<sup>6</sup> NPTS Databook, National Personal Transportation Survey, Volume I, Center for Transportation Analysis, Energy Division, Oak Ridge National Laboratory, Oak Ridge TN, 1993, page 4-108.

<sup>7</sup> Perrin, C., California Department of Transportation, private communications, 1994.

<sup>8</sup> National Transportation Statistics, Annual Report, September 1993, Historical Compendium, 1960-1992, Department of Transportation, 1993, page 198.

during the AM commute time is commuter travel<sup>9</sup>, and the average trip length for all trips is 9.0 miles<sup>10</sup>, there is little error in using the 11 mile trip length for all trips in the peak periods. The resulting number of peak-period trips in the peak period defined (consisting of two, three-hour periods) is 1,520,000 trips. This result is divided by two to obtain the number of peak period trips occurring in each of the two three-hour periods, and is equal to 760,037 trips. Since we know that 95% of these trips are commuting trips (with normally a work day on the order of eight hours), and the average length of the commute is 11 miles, which is close to one-half of the average household vehicle miles traveled per day (23.374), it is assumed that each vehicle makes one trip during each of the two, three-hour peak periods in a day. This allows the translation of the number of trips to the number of vehicles which are potential users of the private vehicle user service group.

NUMBER OF POTENTIAL USERS FOR PRIVATE VEHICLE USER SERVICE GROUP:  
**760,037**

## **E.2 CVO - Long-Haul Service Group Users**

The number of long-haul trucks was obtained from the US Census Bureau<sup>11</sup>, by adding up those truck-type categories that fit the definition of long-haul trucks. The total number that fit the definition is 1 million nationwide, for the 1987 survey. Using the US population for 1987 (242,804,000)<sup>12</sup>, this is one truck for every 242.8 people. It was assumed that these trucks spend one-half of their work day within a metropolitan area, resulting in 500,000 trucks within metropolitan areas, or one truck for every 485.6 people. Trucks are assigned to the Urbansville metropolitan region as a proportion of its population to that of the entire US, so that the Urbansville region population (2,814,950)<sup>13</sup> is divided by 485.6 to arrive at the number of long-haul trucks within the Urbansville region.

NUMBER OF POTENTIAL USERS FOR LONG-HAUL CVO SERVICE GROUP: **5,797**

## **E.3 CVO - Local Service Group Users**

The number of short-haul trucks was obtained from the US Census Bureau<sup>14</sup>, by adding up those truck-type categories that fit the definition of short-haul trucks. The total number that fit the definition is 7 million nationwide, for the 1987 survey. This group includes short-haul trucks, taxis, and automobile fleets. Using the US population for 1987 (242,804,000)<sup>15</sup>, this is one short-haul vehicle for every 34.7 people. Vehicles are assigned to the Urbansville metropolitan region

---

<sup>9</sup> Urban Scenario Guide, Urbansville, October 5, 1993, Integration Simulation Parameter, page 11.

<sup>10</sup> National Transportation Statistics, Annual Report, September 1993, Historical Compendium, 1960-1992, Department of Transportation, 1993, page 198.

<sup>11</sup> Truck Inventory and Use Survey, Census of Transportation, US Bureau of the Census, 1987, page 29.

<sup>12</sup> Statistical Abstract of the United States: 1993, US Bureau of the Census, 1993, page 8.

<sup>13</sup> Urban Scenario Guide, Urbansville, Phase II, March 13, 1995.

<sup>14</sup> Truck Inventory and Use Survey, Census of Transportation, US Bureau of the Census, 1987, page 29.

<sup>15</sup> Statistical Abstract of the United States: 1993, US Bureau of the Census, 1993, page 8.

as a proportion of its population to that of the entire US, so that the Urbansville region population (2,814,950)<sup>16</sup> is divided by 34.7 to arrive at the number of short-haul trucks within the Urbansville region.

NUMBER OF POTENTIAL USERS FOR LOCAL CVO SERVICE GROUP: **81,155**

#### **E.4 Traveler Information Service Group Users**

This group of users includes those accessing information from personal computers at the home or office, and those accessing information from portable computers while traveling. This includes both wireless and wireline access. The number of users is related then to the number of personal computers in the region. The number was taken from the Evaluatory Design Document.

NUMBER OF POTENTIAL USERS OF TRAVELER INFORMATION SERVICES: **200,750**

#### **E.5 Public Transportation Management Service Users**

There were 93,232 local transit vehicles of all types, including buses, light rail, heavy rail, trolleys, and ferries in the US in 1991<sup>17</sup>. Dividing by the US metropolitan-area population (1990 data) of 197,467,000, where bus systems are available, results in 472 such vehicles per million metropolitan area residents. The number of local transit vehicles in the Urbansville area is obtained by multiplying this number by the Urbansville population (resulting in 1329 transit vehicles). To account for the paratransit vehicles, it is assumed that the number of paratransit vehicles is equal to 25% of the transit vehicle number. This gives a total for the transit category of 1329 multiplied by 1.25:

NUMBER OF POTENTIAL USERS OF TRANSIT MANAGEMENT SERVICES: **1,661**

#### **E.6 Emergency Response Vehicles Management Services**

The number of emergency response vehicles is provided in the Urban Scenario Guide, in the Integration simulation parameters section as 0.25% of vehicles<sup>18</sup>.

NUMBER OF POTENTIAL USERS OF EMERGENCY RESPONSE MANAGEMENT SERVICES: **4,444**

#### **E.7 Probes**

The goal is to provide a uniform distribution of probe vehicles throughout the region studied. The limited access highways and arterial surface streets need coverage throughout the day. In order to determine a data loading model, a scenario was developed for optimizing the distribution of probe vehicles in the region: Assuming that there are 225 miles of limited-access highways and 1701 miles of arterial surface streets to be covered, and a desired probe spacing of one mile in each direction of travel, a total of 3852 probe vehicles are required. Adjusting this number by

---

<sup>16</sup> Urban Scenario Guide, Urbansville, Phase II, March 13, 1995.

<sup>17</sup> National Transportation Statistics, Annual Report, September 1993, Historical Compendium, 1960-1992, Department of Transportation, 1993, page 29.

<sup>18</sup> Urban Scenario Guide, Urbansville, Phase II, March 13, 1995.

a factor of two to allow for traffic density variations and variations in local directional flow results in a total of 7704 probe vehicles required. In order to maximize the probe density uniformity, a probe acceptance scheme was assumed, where probes are accepted for participation based on as uniform a distribution as possible. In this scheme potential probe vehicle owners would sign up to participate in the probe program, receiving some financial benefit, or additional service benefits, such as en-route route guidance updates. When leaving on a trip the probe vehicle reports its location and destination to the TMS. The TMS may then accept the vehicle as a probe on that trip if the data is desired. If so, a probe-specific route message is sent to the probe indicating the route and the way point where the probe is to report in. At that way point, the probe vehicle may also receive a new route and a way point for reporting in again.

**NUMBER OF PROBES: 7,704**

## **APPENDIX F MESSAGE DEFINITIONS AND DATA LOADING MODELS**

The complete definitions of the message sets for each scenario and time frame are provided in this appendix. Models are sorted by physical source and sink. The definition of the message is provided, along with the user penetration for that message, frequency of message use, size, and link rate for that message.

The order of the models in the table is: 1997 results appear first, then 2002 results, and finally 2012 results. Within each year the scenario regions are ordered with Urbansville first, Thruville next, and finally Mountainville results. Within the scenario region the models for the user service groups are ordered private vehicle, travelers (PIAS users), CVO-local, CVO-long haul, transit, emergency management, and finally probes. If a model does not appear for a scenario and time frame it is because there were no market packages, and therefore data flows deployed for that scenario/time frame.

The columns of the models are defined as follows. The first column contains the physical architecture source for the message. The second column contains the sink for the message. The data flow name from the logical architecture, which is also the name of the message is shown in the next column. The contents column shows the size of the data flow (in bytes, without the 18-bit message\_id header) if it is a PEL (primitive element) in the logical architecture, or the column lists the subflows within the data flow if the data flow is not a PEL. The direction of message flow is shown next, with the forward direction being defined as the direction away from the center. In cases of messages flowing between vehicles, the flow has been defined as a reverse direction flow to provide a worst-case analysis on contention-based reverse channels. The penetration column shows the penetration for that particular message for that particular scenario. It is based on the penetration for the market package to which the message belongs. The frequency of use is defined as the number of uses of that message per user for the entire peak period of a day. For private vehicles, travelers, and probes this is a total of six hours. For CVO this is 12 hours. For emergency management and transit this is 13 hours. Frequencies of use are based on the best engineering judgment for the average user of that market package. The “freq” column contains the product of the message frequency of use times the penetration times the ul1 fraction. The explanation for the frequency of use is shown in the next column. In some cases the explanation will differ from the “freq” column by exactly the factor explained earlier in the body of this document as the fraction of the number of users of this message that are assigned to the wireless interface, where users are split between wireless and wireline, or another communications interface. The size column shows the size of the message in bits. An 18-bit message\_id header has been added to the logical data flow size at this point. The final columns contain the average peak period data rate that results from the particular message on the wide area wireless interface in bits per second per user.

Table F-1 Data Loading Models for the Wide-Area Wireless Two-Way (u1t) Interface.

<b>Private Vehicle, 1997, Urbansville</b>											
PA Source	PA Sink	Data Flow	Contents	Dir c.	Pen e tra ti on	freq	Freq. Explain	Fwd bits	Rev bits	Fwd rate (b/s/u)	Rev rate (b/s/u)
EM	VS	emergency_request_driver_acknowledge	=1	f	0.05	5E-05	one emergency per 1000 vehicles per peak period	26	0	6.02E-08	
EM	VS	emergency_request_vehicle_acknowledge	=1	f	0.05	5E-05	one emergency per 1000 vehicles per peak period	26	0	6.02E-08	
VS	EM	emergency_request_driver_details	=date+driver_personal_emergency_request+time	r	0.05	5E-05	one emergency per 1000 vehicles per peak period	0	282		6.53E-07
VS	EM	emergency_request_vehicle_details	=date+time+vehicle_emergency_request	r	0.05	5E-05	one emergency per 1000 vehicles per peak period	0	3354		7.76E-06
VS	ISP	advisory_data_request	=advisory_data_scope+vehicle_location_for_advisories+transit_route_number+transit_vehicle_identity	r	0.01	0.01	one request per vehicle per peak period	0	290		1.34E-04
<b>TOTALS (b/s/user):</b>										<b>1.20E-07</b>	<b>1.43E-04</b>



## Traveler, 1997, Urbansville

PA Source	PA Sink	Data Flow	Contents	Dir c.	Pene trati on	freq	Freq. Explain	Fwd bits	Rev bits	Fwd rate (b/s/u)	Rev rate (b/s/u)
EM	PIAS	emergency_request_personal_traveler_acknowledge	=confirmation_flag	f	0.05	1E-05	one emergency per 2000 users in peak period	26	0	1.50E-08	
ISP	PIAS	transit_deviations_for_portables	=traveler_identity+list_size+TRANSIT_SEGS*(transit_vehicle_identity+transit_vehicle_achieved_time+transit_route_segment_number)	f	0.01	3E-05	one request per 20 pias per peak period	3578	0	4.14E-06	
PIAS	EM	emergency_request_personal_traveler_details	=date+time+traveler_personal_emergency_request	r	0.05	1E-05	one emergency per 2000 users in peak period	0	370		2.14E-07
PIAS	ISP	traffic_data_portables_request	=traffic_data_request+traveler_identity	r	0.01	0.005	one request per pias per peak period	0	250		5.79E-05
PIAS	ISP	transit_deviations_portables_request	=traveler_identity+transit_vehicle_deviation_request+transit_route_number	r	0.01	3E-04	one request per 20 pias per peak period	0	250		2.89E-06
<b>TOTALS (b/s/user):</b>										<b>4.16E-06</b>	<b>6.10E-05</b>

## CVO-Local, 1997, Urbansville

PA Source	PA Sink	Data Flow	Contents	Dir	Penetration	freq	Freq. Explain	Fwd bits	Rev bits	Fwd rate (b/s/u)	Rev rate (b/s/u)
CVS	FMS	cf_driver_route_instructions_request	=cv_driver_number+cv_route_number	r	0.25	0.5	average fleet vehicle requests two routes per peak period	0	154		1.78E-03
CVS	FMS	cv_driver_route_request	=trip_request+route_type	r	0.25	1	average vehicle requests 4 routes per peak period	0	1234		2.86E-02
CVS	FMS	cv_driver_storage_request	=cv_route_number	r	0.25	0.025	one in ten vehicles per peak period	0	26		1.50E-05
CVS	FMS	cv_static_route_data	=256	r	0.25	1	four routes per vehicle per peak period	0	2066		4.78E-02
EM	VS	emergency_request_driver_acknowledge	=1	f	0.05	5E-05	one emergency per 1000 vehicles per peak period	26	0	3.01E-08	
EM	VS	emergency_request_vehicle_acknowledge	=1	f	0.05	5E-05	one emergency per 1000 vehicles per peak period	26	0	3.01E-08	
FMS	CVS	cf_driver_route_instructions	=cf_driver_route+cf_driver_load_details	f	0.25	0.5	twice per vehicle per peak period	5082	0	5.88E-02	
FMS	CVS	cv_driver_route_data	=cv_route_data+route_type+cv_route_number	f	0.25	1	average vehicle requests four routes per peak period	3042	0	7.04E-02	
FMS	CVS	cv_static_route_request	=origin+destination+departure_time+desired_arrival_time+preferences+constraints	f	0.25	1	average vehicle requests four routes per peak period	1226	0	2.84E-02	
FMS	ImFrghD	To_Intermodal_Freight_Depot	=64	r	0.25	0.003	one in ten of vehicles interact once with an intermodal carrier	0	530		3.07E-05
FMS	ImFrghS	To_Intermodal_Freight_Shipper	=64	r	0.25	0.003	one in ten of vehicles interact once with an intermodal carrier	0	530		3.07E-05
FMS	ISP	cf_route_request	=trip_request+cv_route_number	r	0.25	0.05	twice per vehicle per peak period	0	1234		1.43E-03
FMS	ISP	cv_route_request	=trip_request+vehicle_identity	r	0.25	0.1	four times per vehicle per peak period	0	1354		3.13E-03
ImFrghD	FMS	From_Intermodal_Freight_Depot	=64	f	0.25	0.003	one in ten of vehicles interact once with an intermodal carrier	530	0	3.07E-05	

## CVO-Local, 1997, Urbansville

ImFrghtS	FMS	From_Intermodal_Freight_Shipper	=64	f	0.25	0.003	one in ten of vehicles interact once with an intermodal carrier	530	0	3.07E-05	
ISP	FMS	cf_route	=cv_route_data+cv_route_number	f	0.25	0.05	twice per vehicle per peak period	3034	0	3.51E-03	
ISP	FMS	cv_route	=cv_route_data+vehicle_identity	f	0.25	0.1	four times per vehicle per peak period	3154	0	7.30E-03	
VS	EM	emergency_request_driver_details	=date+driver_personal_emergency_request+time	r	0.05	5E-05	one emergency per 1000 vehicles per peak period	0	282		3.26E-07
VS	EM	emergency_request_vehicle_details	=date+time+vehicle_emergency_request	r	0.05	5E-05	one emergency per 1000 vehicles per peak period	0	3354		3.88E-06
VS	ISP	advisory_data_request	=advisory_data_scope+vehicle_location_for_advisories+transit_route_number+transit_vehicle_identity	r	0.01	0.02	two requests per vehicle per peak period	0	290		1.34E-04
<b>TOTALS (b/s/user):</b>										<b>1.68E-01</b>	<b>8.29E-02</b>

## CVO-Long Haul, 1997, Urbansville

PA Source	PA Sink	Data Flow	Contents	Dir c.	Pene tration	freq	Freq. Explain	Fwd bits	Rev bits	Fwd rate (b/s/u)	Rev rate (b/s/u)
CVS	FMS	cf_driver_route_instructions_request	=cv_driver_number+cv_route_number	r	0.25	0.25	average fleet vehicle requests one route per peak period	0	154		8.91E-04
CVS	FMS	cv_driver_route_request	=trip_request+route_type	r	0.25	0.5	average vehicle requests 2 routes per peak period	0	1234		1.43E-02
CVS	FMS	cv_driver_storage_request	=cv_route_number	r	0.25	0.025	one in ten vehicles per peak period	0	26		1.50E-05
CVS	FMS	cv_static_route_data	=256	r	0.25	0.5	two routes per vehicle per peak period	0	2066		2.39E-02
EM	VS	emergency_request_driver_acknowledge	=1	f	0.05	5E-05	one emergency per 1000 vehicles per peak period	26	0	3.01E-08	
EM	VS	emergency_request_vehicle_acknowledge	=1	f	0.05	5E-05	one emergency per 1000 vehicles per peak period	26	0	3.01E-08	
FMS	CVS	cf_driver_route_instructions	=cf_driver_route+cf_driver_load_details	f	0.25	0.25	once per vehicle per peak period	5082	0	2.94E-02	
FMS	CVS	cv_driver_route_data	=cv_route_data+route_type+cv_route_number	f	0.25	0.5	average vehicle requests two routes per peak period	3042	0	3.52E-02	
FMS	CVS	cv_static_route_request	=origin+destination+departure_time+desired_arrival_time+preferences+constraints	f	0.25	0.5	average vehicle requests two routes per peak period	1226	0	1.42E-02	
FMS	ImFrghD	To_Intermodal_Freight_Depot	=64	r	0.25	0.003	one in ten vehicles interacts once with an intermodal carrier	0	530		3.07E-05
FMS	ImFrghS	To_Intermodal_Freight_Shipper	=64	r	0.25	0.003	one in ten vehicles interacts once with an intermodal carrier	0	530		3.07E-05
FMS	ISP	cf_route_request	=trip_request+cv_route_number	r	0.25	0.025	once per vehicle per peak period	0	1234		7.14E-04
FMS	ISP	cv_route_request	=trip_request+vehicle_identity	r	0.25	0.05	twice per vehicle per peak period	0	1354		1.57E-03
ImFrghD	FMS	From_Intermodal_Freight_Depot	=64	f	0.25	0.003	one in ten vehicles interacts once with an intermodal carrier	530	0	3.07E-05	

## CVO-Long Haul, 1997, Urbansville

ImFrghtS	FMS	From_Intermodal_Freight_Shipper	=64	f	0.25	0.003	one in ten vehicles interacts once with an intermodal carrier	530	0	3.07E-05	
ISP	FMS	cf_route	=cv_route_data+cv_route_number	f	0.25	0.025	once per vehicle per peak period	3034	0	1.76E-03	
ISP	FMS	cv_route	=cv_route_data+vehicle_identity	f	0.25	0.05	twice per vehicle per peak period	3154	0	3.65E-03	
VS	EM	emergency_request_driver_details	=date+driver_personal_emergency_request+time	r	0.05	5E-05	one emergency per 1000 vehicles per peak period	0	282		3.26E-07
VS	EM	emergency_request_vehicle_details	=date+time+vehicle_emergency_request	r	0.05	5E-05	one emergency per 1000 vehicles per peak period	0	3354		3.88E-06
VS	ISP	advisory_data_request	=advisory_data_scope+vehicle_location_for_advisories+transit_route_number+transit_vehicle_identity	r	0.01	0.02	two requests per vehicle per peak period	0	290		1.34E-04
<b>TOTALS (b/s/user):</b>										<b>8.43E-02</b>	<b>4.16E-02</b>

## Transit, 1997, Urbansville

PA Source	PA Sink	Data Flow	Contents	Dir c.	Pene tration	freq	Freq. Explain	Fwd bits	Rev bits	Fwd rate (b/s/u)	Rev rate (b/s/u)
RTS	ISP	traffic_data_kiosk_request	=kiosk_identity+traffic_data_request	r	0.01	0.032	average of one use per transit user per peak period = 32 per transit vehicle	0	98		6.70E-05
RTS	ISP	transit_deviation_kiosk_request	=kiosk_identity+transit_vehicle_deviation_request	r	0.01	0.006	one in five transit users = 6.4 per transit vehicle per peak period	0	66		9.03E-06
RTS	ISP	traveler_current_condition_request	=kiosk_identity	r	0.01	0.032	average of one use per transit user per peak period = 32 per transit vehicle	0	58		3.97E-05
TRMS	TRVS	approved_corrective_plan	=transit_route_corrections+transit_changes_in_stops+transit_changes_in_speed	f	0.66	0.066	one corrective message per ten vehicles per peak period	8210	0	1.16E-02	
TRMS	TRVS	paratransit_transit_driver_instructions	=128	f	0.66	8.58	dispatch message every 15 min. during peak period=48/4(ratio of paratr/tr veh)	1042	0	1.91E-01	
TRMS	TRVS	transit_services_for_corrections	=list_size+1*(2/NUM_TRANSIT_ROUTES)*(transit_services)	f	0.66	8.58	one correction per hour during the peak period	17260	0	3.16E+00	
TRMS	TRVS	transit_services_for_eta	=transit_route_number+transit_route_segment_list+transit_route_stop_list	f	0.66	34.32	update every 15 minutes during the peak period	7786	0	5.71E+00	
TRVS	TRMS	paratransit_transit_vehicle_availability	=1	r	0.66	8.58	avail. message every 15 min. during peak period=48/4(ratio of paratr/tr veh)	0	26		4.77E-03
TRVS	TRMS	transit_conditions_request	=2	r	0.66	0.066	one corrective message per ten vehicles per peak period	0	34		4.79E-05
TRVS	TRMS	transit_services_for_eta_request	=transit_vehicle_identity+transit_route_number+transit_route_schedule_number	r	0.66	2.112	average of one use per 10 transit users per peak period=3.2 per transit vehicle	0	186		8.39E-03

## Transit, 1997, Urbansville

TRVS	TRMS	transit_vehicle_arrival_conditions	=128	r	0.33	4.29	updated every 60 minutes during the peak period	0	1042		9.55E-02
TRVS	TRMS	transit_vehicle_deviations_from_schedule	=32	r	0.66	34.32	update every 15 minutes during the peak period	0	274		2.01E-01
TRVS	TRMS	transit_vehicle_eta	=transit_vehicle_identity+transit_vehicle_time+transit_route_number	r	0.33	51.48	updated every 5 minutes during the peak period	0	234		2.57E-01
TRVS	TRMS	transit_vehicle_location	=transit_vehicle_identity+transit_vehicle_location_data	r	0.33	17.16	updated every 15 minutes during the peak period	0	250		9.17E-02
TRVS	TRMS	transit_vehicle_location_for_deviation	=transit_vehicle_identity+transit_vehicle_location_data	r	0.33	17.16	updated every 15 minutes during the peak period	0	250		9.17E-02
TRVS	TRMS	transit_vehicle_location_for_store	=transit_vehicle_identity+transit_vehicle_location_data	r	0.33	4.29	updated every 60 minutes during the peak period	0	250		2.29E-02
TRVS	TRMS	transit_vehicle_schedule_deviation	=32	r	0.33	17.16	updated every 15 minutes during the peak period	0	274		1.00E-01
<b>TOTALS (b/s/user):</b>									<b>9.08E+00</b>	<b>8.74E-01</b>	

## Emergency Management, 1997, Urbansville

PA Source	PA Sink	Data Flow	Contents	Direc.	Penetration	freq	Freq. Explain	Fwd bits	Rev bits	Fwd rate (b/s/u)	Rev rate (b/s/u)
EM	EVS	emergency_vehicle_driver_outputs	=128	f	0.5	6.5	average one driver output per vehicle per hour during the peak period	1042	0	1.45E-01	
EVS	EM	emergency_driver_dispatch_acknowledge	=1	r	0.5	13	average one dispatch acknowledge per vehicle per 1/2 hour during the peak period	0	26		7.22E-03
EVS	EM	emergency_driver_status_update	=16	r	0.5	13	average one status update per vehicle per 1/2 hour during the peak period	0	146		4.06E-02
EVS	EM	emergency_vehicle_driver_inputs	=64	r	0.5	6.5	average one driver input per vehicle per hour during the peak period	0	530		7.36E-02
<b>TOTALS (b/s/user):</b>										<b>1.45E-01</b>	<b>1.21E-01</b>

## Probes, 1997, Urbansville

PA Source	PA Sink	Data Flow	Contents	Direc.	Penetration	freq	Freq. Explain	Fwd bits	Rev bits	Fwd rate (b/s/u)	Rev rate (b/s/u)
VS	ISP	vehicle_guidance_probe_data	=route_segment_identity+vehicle_identity	r	1	12	average of 12 probe reports per vehicle per peak period	0	314		1.74E-01
<b>TOTALS (b/s/user):</b>										<b>0.00E+00</b>	<b>1.74E-01</b>



## CVO-Local, 1997, Thruville

PA Source	PA Sink	Data Flow	Contents	Dir	Penetration	freq	Freq. Explain	Fwd bits	Rev bits	Fwd rate (b/s/u)	Rev rate (b/s/u)
CVS	FMS	cf_driver_route_instructions_request	=cv_driver_number+cv_route_number	r	0.25	0.5	average fleet vehicle requests two routes per peak period	0	154		1.78E-03
CVS	FMS	cv_driver_route_request	=trip_request+route_type	r	0.25	1	average vehicle requests 4 routes per peak period	0	1234		2.86E-02
CVS	FMS	cv_driver_storage_request	=cv_route_number	r	0.25	0.025	one in ten vehicles per peak period	0	26		1.50E-05
CVS	FMS	cv_static_route_data	=256	r	0.25	1	four routes per vehicle per peak period	0	2066		4.78E-02
FMS	CVS	cf_driver_route_instructions	=cf_driver_route+cf_driver_load_details	f	0.25	0.5	twice per vehicle per peak period	5082	0	5.88E-02	
FMS	CVS	cv_driver_route_data	=cv_route_data+route_type+cv_route_number	f	0.25	1	average vehicle requests four routes per peak period	3042	0	7.04E-02	
FMS	CVS	cv_static_route_request	=origin+destination+departure_time+desired_arrival_time+preferences+constraints	f	0.25	1	average vehicle requests four routes per peak period	1226	0	2.84E-02	
FMS	ImFrghD	To_Intermodal_Freight_Depot	=64	r	0.25	0.003	one in ten of vehicles interact once with an intermodal carrier	0	530		3.07E-05
FMS	ImFrghS	To_Intermodal_Freight_Shipper	=64	r	0.25	0.003	one in ten of vehicles interact once with an intermodal carrier	0	530		3.07E-05
FMS	ISP	cf_route_request	=trip_request+cv_route_number	r	0.25	0.05	twice per vehicle per peak period	0	1234		1.43E-03
FMS	ISP	cv_route_request	=trip_request+vehicle_identity	r	0.25	0.1	four times per vehicle per peak period	0	1354		3.13E-03
ImFrghD	FMS	From_Intermodal_Freight_Depot	=64	f	0.25	0.003	one in ten of vehicles interact once with an intermodal carrier	530	0	3.07E-05	
ImFrghS	FMS	From_Intermodal_Freight_Shipper	=64	f	0.25	0.003	one in ten of vehicles interact once with an intermodal carrier	530	0	3.07E-05	

<b>CVO-Local, 1997, Thruville</b>											
ISP	FMS	cf_route	=cv_route_data+cv_route_number	f	0.25	0.05	twice per vehicle per peak period	3034	0	3.51E-03	
ISP	FMS	cv_route	=cv_route_data+vehicle_identity	f	0.25	0.1	four times per vehicle per peak period	3154	0	7.30E-03	
<b>TOTALS (b/s/user):</b>										<b>1.68E-01</b>	<b>8.28E-02</b>

<b>CVO-Long Haul, 1997, Thruville</b>											
PA Source	PA Sink	Data Flow	Contents	Direc.	Penetration	freq	Freq. Explain	Fwd bits	Rev bits	Fwd rate (b/s/u)	Rev rate (b/s/u)
CVS	FMS	cf_driver_route_instructions_request	=cv_driver_number+cv_route_number	r	0.25	0.25	average fleet vehicle requests one route per peak period	0	154		8.91E-04
CVS	FMS	cv_driver_route_request	=trip_request+route_type	r	0.25	0.5	average vehicle requests 2 routes per peak period	0	1234		1.43E-02
CVS	FMS	cv_driver_storage_request	=cv_route_number	r	0.25	0.025	one in ten vehicles per peak period	0	26		1.50E-05
CVS	FMS	cv_static_route_data	=256	r	0.25	0.5	two routes per vehicle per peak period	0	2066		2.39E-02
FMS	CVS	cf_driver_route_instructions	=cf_driver_route+cf_driver_load_details	f	0.25	0.25	once per vehicle per peak period	5082	0	2.94E-02	
FMS	CVS	cv_driver_route_data	=cv_route_data+route_type+cv_route_number	f	0.25	0.5	average vehicle requests two routes per peak period	3042	0	3.52E-02	
FMS	CVS	cv_static_route_request	=origin+destination+departure_time+desired_arrival_time+preferences+constraints	f	0.25	0.5	average vehicle requests two routes per peak period	1226	0	1.42E-02	
FMS	ImFrghD	To_Intermodal_Freight_Depot	=64	r	0.25	0.003	one in ten vehicles interacts once with an intermodal carrier	0	530		3.07E-05
FMS	ImFrghS	To_Intermodal_Freight_Shipper	=64	r	0.25	0.003	one in ten vehicles interacts once with an intermodal carrier	0	530		3.07E-05
FMS	ISP	cf_route_request	=trip_request+cv_route_number	r	0.25	0.025	once per vehicle per peak period	0	1234		7.14E-04

## CVO-Long Haul, 1997, Thruville

FMS	ISP	cv_route_request	=trip_request+vehicle_identity	r	0.25	0.05	twice per vehicle per peak period	0	1354		1.57E-03	
ImFrghtD	FMS	From_Intermodal_Freight_Depot	=64	f	0.25	0.003	one in ten vehicles interacts once with an intermodal carrier	530	0	3.07E-05		
ImFrghtS	FMS	From_Intermodal_Freight_Shipper	=64	f	0.25	0.003	one in ten vehicles interacts once with an intermodal carrier	530	0	3.07E-05		
ISP	FMS	cf_route	=cv_route_data+cv_route_number	f	0.25	0.025	once per vehicle per peak period	3034	0	1.76E-03		
ISP	FMS	cv_route	=cv_route_data+vehicle_identity	f	0.25	0.05	twice per vehicle per peak period	3154	0	3.65E-03		
<b>TOTALS (b/s/user):</b>											<b>8.43E-02</b>	<b>4.14E-02</b>

## Transit, 1997, Thruville

PA Source	PA Sink	Data Flow	Contents	Direction	Penetration	freq	Freq. Explain	Fwd bits	Rev bits	Fwd rate (b/s/u)	Rev rate (b/s/u)
TRMS	TRVS	approved_corrective_plan	=transit_route_corrections+transit_changes_in_stops+transit_changes_in_speed	f	0.66	0.066	one corrective message per ten vehicles per peak period	8210	0	1.16E-02	
TRMS	TRVS	paratransit_transit_driver_instructions	=128	f	0.66	8.58	dispatch message every 15 min. during peak period=48/4(ratio of paratr/tr veh)	1042	0	1.91E-01	
TRMS	TRVS	transit_services_for_corrections	=list_size+1*(2/NUM_TRANSIT_ROUTES)*(transit_services)	f	0.66	8.58	one correction per hour during the peak period	17260	0	3.16E+00	
TRMS	TRVS	transit_services_for_eta	=transit_route_number+transit_route_segment_list+transit_route_stop_list	f	0.66	34.32	update every 15 minutes during the peak period	7786	0	5.71E+00	
TRVS	TRMS	paratransit_transit_vehicle_availability	=1	r	0.66	8.58	avail. message every 15 min. during peak period=48/4(ratio of paratr/tr veh)	0	26		4.77E-03
TRVS	TRMS	transit_conditions_request	=2	r	0.66	0.066	one corrective message per ten vehicles per peak period	0	34		4.79E-05
TRVS	TRMS	transit_services_for_eta_request	=transit_vehicle_identity+transit_route_number+transit_route_schedule_number	r	0.66	2.112	average of one use per 10 transit users per peak period=3.2 per transit vehicle	0	186		8.39E-03
TRVS	TRMS	transit_vehicle_arrival_conditions	=128	r	0.33	4.29	updated every 60 minutes during the peak period	0	1042		9.55E-02
TRVS	TRMS	transit_vehicle_deviations_from_schedule	=32	r	0.66	34.32	update every 15 minutes during the peak period	0	274		2.01E-01
TRVS	TRMS	transit_vehicle_eta	=transit_vehicle_identity+transit_vehicle_time+transit_route_number	r	0.33	51.48	updated every 5 minutes during the peak period	0	234		2.57E-01
TRVS	TRMS	transit_vehicle_location	=transit_vehicle_identity+transit_vehicle_location_data	r	0.33	17.16	updated every 15 minutes during the peak period	0	250		9.17E-02
TRVS	TRMS	transit_vehicle_location_for_deviation	=transit_vehicle_identity+transit_vehicle_location_data	r	0.33	17.16	updated every 15 minutes during the peak period	0	250		9.17E-02

<b>Transit, 1997, Thruville</b>											
TRVS	TRMS	transit_vehicle_location_for_store	=transit_vehicle_identity+transit_vehicle_location_data	r	0.33	4.29	updated every 60 minutes during the peak period	0	250		2.29E-02
TRVS	TRMS	transit_vehicle_schedule_deviation	=32	r	0.33	17.16	updated every 15 minutes during the peak period	0	274		1.00E-01
<b>TOTALS (b/s/user):</b>										<b>9.08E+00</b>	<b>8.74E-01</b>

<b>Emergency Management, 1997, Thruville</b>											
PA Source	PA Sink	Data Flow	Contents	Dir	Penetration	freq	Freq. Explain	Fwd bits	Rev bits	Fwd rate (b/s/u)	Rev rate (b/s/u)
EM	EVS	emergency_vehicle_driver_outputs	=128	f	0.5	6.5	average one driver output per vehicle per hour during the peak period	1042	0	1.45E-01	
EVS	EM	emergency_driver_dispatch_acknowledge	=1	r	0.5	13	average one dispatch acknowledge per vehicle per 1/2 hour during the peak period	0	26		7.22E-03
EVS	EM	emergency_driver_statuses_update	=16	r	0.5	13	average one status update per vehicle per 1/2 hour during the peak period	0	146		4.06E-02
EVS	EM	emergency_vehicle_driver_inputs	=64	r	0.5	6.5	average one driver input per vehicle per hour during the peak period	0	530		7.36E-02
<b>TOTALS (b/s/user):</b>										<b>1.45E-01</b>	<b>1.21E-01</b>

Probes, 1997, Thruville												
PA Source	PA Sink	Data Flow	Contents	Dir c.	Penetration	freq	Freq. Explain	Fwd bits	Rev bits	Fwd rate (b/s/u)	Rev rate (b/s/u)	
VS	ISP	vehicle_guidance_probe_data	=route_segment_identity+vehicle_identity	r	1	12	average of 12 probe reports per vehicle per peak period	0	314		1.74E-01	
<b>TOTALS (b/s/user):</b>										<b>0.00E+00</b>	<b>1.74E-01</b>	

Private Vehicle, 2002, Urbansville												
PA Source	PA Sink	Data Flow	Contents	Dir c.	Penetration	freq	Freq. Explain	Fwd bits	Rev bits	Fwd rate (b/s/u)	Rev rate (b/s/u)	
EM	VS	emergency_request_driver_acknowledge	=1	f	0.1	1E-04	one emergency per 1000 vehicles per peak period	26	0	1.20E-07		
EM	VS	emergency_request_vehicle_acknowledge	=1	f	0.1	1E-04	one emergency per 1000 vehicles per peak period	26	0	1.20E-07		
ISP	VS	advanced_fares_and_charges_response	=confirmation_flag+credit_identity+parking_lot_cost+stored_credit+transit_fare	f	0.1	1E-04	one user per 1000 users per peak period	234	0	1.08E-06		
ISP	VS	advanced_tolls_and_fares_response	=confirmation_flag+credit_identity+stored_credit+tolll_cost+transit_fare	f	0.1	1E-04	one user per 1000 users per peak period	234	0	1.08E-06		
ISP	VS	advisory_data	=traffic_data_for_advisories+predicted_incidents_for_advisories+prediction_data_for_advisories+transit_services_for_advisories+transit_running_data_for_advisories	f	0.1	0.1	one set of data per peak period	6146	0	2.85E-02		
ISP	VS	yellow_pages_advisory_data	=yellow_pages_data_for_advisories+yellow_pages_cost+yellow_pages_dining_reservation_confirmation+yellow_pages_lodging_reservation_confirmation+yellow_pages_ticket_purchase_confirmation	f	0.1	0.01	one yellow pages advisory per 10 vehicles per peak period	10802	0	5.00E-03		
LocData	VS	From_Location_Data_Source	=16	f	0.07	0.007	one in ten vs uses per peak period	146	0	4.73E-05		
PayInstr	VS	fpi_driver_vehicle_input_credit_identity	=credit_identity	f	0.1	1E-04	one vehicle per 1000 per peak period	178	0	8.24E-07		

<b>Private Vehicle, 2002, Urbansville</b>											
PayInstr	VS	fpi_transit_user_vehicle_input_credit_identity	=credit_identity	f	1	1E-04	one in 10000 vehicles uses this flow per peak period	178	0	8.24E-07	
VS	EM	emergency_request_driver_details	=date+driver_personal_emergency_request+time	r	0.1	1E-04	one emergency per 1000 vehicles per peak period	0	282		1.31E-06
VS	EM	emergency_request_vehicle_details	=date+time+vehicle_emergency_request	r	0.1	1E-04	one emergency per 1000 vehicles per peak period	0	3354		1.55E-05
VS	ISP	advanced_fares_and_charges_request	=0.6*(advanced_fare_details)+0.6*(advanced_parking_lot_charges)	r	0.1	1E-04	one user per 1000 users per peak period	0	632.4		2.93E-06
VS	ISP	advanced_tolls_and_fares_request	=0.6*(advanced_fare_details)+0.6*(advanced_tolls)	r	0.1	1E-04	one user per 1000 users per peak period	0	642		2.97E-06
VS	ISP	advisory_data_request	=advisory_data_scope+vehicle_location_for_advisories+transit_route_number+transit_vehicle_identity	r	0.1	0.1	one request per vehicle per peak period	0	290		1.34E-03
VS	ISP	vehicle_guidance_route_accepted	=route_identity	r	0.07	0.14	two acceptances per peak period	0	34		2.20E-04
VS	ISP	yellow_pages_advisory_requests	=advisory_data_scope+vehicle_location_for_advisories+transit_route_number+transit_vehicle_identity+yellow_pages_dining_reservation+yellow_pages_lodging_reservation+yellow_pages_ticket_purchase	r	0.1	0.01	one yellow pages advisory per ten vehicles per peak period	0	674		3.12E-04
VS	PayInstr	tpi_debited_driver_payment_at_vehicle	=4	r	0.1	1E-04	one vehicle per 1000 per peak period	0	50		2.31E-07
VS	PMS	advanced_parking_lot_charges_request	=credit_identity+parking_lot_identity+parking_space_details+stored_credit+vehicle_identity	r	0.1	5E-05	one user per 1000 users per peak period	0	514		1.19E-06
VS	PMS	parking_lot_payment_confirmation	=confirmation_flag	r	0.1	5E-05	one vehicle per 1000 per peak period	0	26		6.02E-08
<b>TOTALS (b/s/user):</b>										<b>3.35E-02</b>	<b>1.90E-03</b>

## Traveler, 2002, Urbansville

PA Source	PA Sink	Data Flow	Contents	Dir c.	Penetration	freq	Freq. Explain	Fwd bits	Rev bits	Fwd rate (b/s/u)	Rev rate (b/s/u)
EM	PIAS	emergency_request_personal_traveler_acknowledge	=confirmation_flag	f	0.1	3E-05	one emergency per 2000 users in peak period	26	0	3.01E-08	
ISP	PIAS	transit_deviations_for_portables	=traveler_identity+list_size+TRANSIT_SEGS*(transit_vehicle_identity+transit_vehicle_achieved_time+transit_route_segment_number)	f	0.1	3E-04	one request per 20 pias per peak period	3578	0	4.14E-05	
ISP	PIAS	traveler_guidance_route	=route_identity+traveler_route+traveler_identity	f	0.07	0.004	one route per day per pias	18306	0	2.97E-03	
ISP	PIAS	traveler_personal_payment_confirmation	=advanced_tolls_confirm+advanced_fares_confirm+advanced_parking_lot_charges_confirm+credit_identity+stored_credit+traveler_identity+traveler_total_trip_cost	f	0.1	0.005	one payment per 10 pias per peak period	818	0	1.89E-04	
ISP	PIAS	traveler_personal_transaction_confirmation	=credit_identity+traveler_identity+transaction_number+yellow_pages_cost+yellow_pages_lodging_reservation_confirmation+yellow_pages_dining_reservation_confirmation+yellow_pages_ticket_purchase_confirmation	f	0.1	0.005	one confirmation per 10 pias per day	650	0	1.50E-04	
ISP	PIAS	traveler_personal_yellow_pages_data	=traveler_identity+0.01*(yellow_pages_general_information+yellow_pages_specific_information+yellow_pages_transaction_information)	f	0.1	0.05	one yellow pages response per pias per peak period	1140	0	2.64E-03	
LocData	PIAS	From_Location_Data_Source	=16	f	0.07	0.007	one in ten pias uses per peak period	146	0	4.73E-05	
PayInstr	PIAS	fpi_traveler_personal_input_credit_identity	=credit_identity	f	0.1	0.005	one transaction per 10 pias per day	178	0	4.12E-05	
PIAS	EM	emergency_request_personal_traveler_details	=date+time+traveler_personal_emergency_request	r	0.1	3E-05	one emergency per 2000 users in peak period	0	370		4.28E-07
PIAS	ISP	traffic_data_portables_request	=traffic_data_request+traveler_identity	r	0.1	0.05	one request per pias per peak period	0	250		5.79E-04
PIAS	ISP	transit_deviations_portables_request	=traveler_identity+transit_vehicle_deviation_request+transit_route_number	r	0.1	0.003	one request per 20 pias per peak period	0	250		2.89E-05



<b>Traveler, 2002, Urbansville</b>											
PIAS	ISP	traveler_personal_current_condition_request	=traveler_identity	r	0.1	0.05	one request per pias per peak period	0	210		4.86E-04
PIAS	ISP	traveler_personal_payment_information	=credit_identity+parking_space_details+ride_segments+stored_credit+toll_segments+traveler_identity	r	0.1	0.005	one payment per 10 pias per peak period	0	1130		2.62E-04
PIAS	ISP	traveler_personal_transaction_request	=yellow_pages_dining_reservation+yellow_pages_lodging_reservation+yellow_pages_ticket_purchase	r	0.1	0.005	one request per 10 pias per peak period	0	402		9.31E-05
PIAS	ISP	traveler_personal_yellow_pages_information_request	=1	r	0.1	0.05	one yellow pages request per pias per peak period	0	26		6.02E-05
PIAS	PayInstr	tpi_debited_payment_at_personal_device	=4	r	0.1	0.005	one transaction per 10 pias per day	0	50		1.16E-05
PIAS	TRMS	transit_services_portables_request	=destination+origin+traveler_identity	r	0.1	0.005	one request per 10 pias per peak period	0	466		1.08E-04
TRMS	PIAS	transit_services_for_portables	=traveler_identity+2*(transit_services_for_output)	f	0.1	0.002	one request per 20 pias per peak period	2530	0	1.93E-04	
<b>TOTALS (b/s/user):</b>									<b>6.27E-03</b>	<b>1.63E-03</b>	

## CVO-Local, 2002, Urbansville

PA Source	PA Sink	Data Flow	Contents	Dir	Penetration	freq	Freq. Explain	Fwd bits	Rev bits	Fwd rate (b/s/u)	Rev rate (b/s/u)
CVS	FMS	cf_driver_route_instructions_request	=cv_driver_number+cv_route_number	r	0.5	1	average fleet vehicle requests two routes per peak period	0	154		3.56E-03
CVS	FMS	cv_driver_route_request	=trip_request+route_type	r	0.5	2	average vehicle requests 4 routes per peak period	0	1234		5.71E-02
CVS	FMS	cv_driver_storage_request	=cv_route_number	r	0.5	0.05	one in ten vehicles per peak period	0	26		3.01E-05
CVS	FMS	cv_static_route_data	=256	r	0.5	2	four routes per vehicle per peak period	0	2066		9.56E-02
EM	FMS	cf_hazmat_request	=16	f	0.1	1E-05	once per 1000 vehicles per peak period	146	0	3.38E-08	
EM	VS	emergency_request_driver_acknowledge	=1	f	0.1	1E-04	one emergency per 1000 vehicles per peak period	26	0	6.02E-08	
EM	VS	emergency_request_vehicle_acknowledge	=1	f	0.1	1E-04	one emergency per 1000 vehicles per peak period	26	0	6.02E-08	
FMS	CVS	cf_driver_route_instructions	=cf_driver_route+cf_driver_load_details	f	0.5	1	twice per vehicle per peak period	5082	0	1.18E-01	
FMS	CVS	cv_driver_route_data	=cv_route_data+route_type+cv_route_number	f	0.5	2	average vehicle requests four routes per peak period	3042	0	1.41E-01	
FMS	CVS	cv_static_route_request	=origin+destination+departure_time+desired_arrival_time+preferences+constraints	f	0.5	2	average vehicle requests four routes per peak period	1226	0	5.68E-02	
FMS	EM	cf_hazmat_route_information	=cv_route_number+route	r	0.1	1E-05	once per 1000 vehicles per peak period	0	3754		8.69E-07
FMS	EM	cf_hazmat_vehicle_information	=28	r	0.1	1E-05	once per 1000 vehicles per peak period	0	242		5.60E-08
FMS	ImFrghD	To_Intermodal_Freight_Depot	=64	r	0.5	0.005	one in ten of vehicles interact once with an intermodal carrier	0	530		6.13E-05
FMS	ImFrghS	To_Intermodal_Freight_Shipper	=64	r	0.5	0.005	one in ten of vehicles interact once with an intermodal carrier	0	530		6.13E-05

## CVO-Local, 2002, Urbansville

FMS	ISP	cf_route_request	=trip_request+cv_route_number	r	0.5	0.1	twice per vehicle per peak period	0	1234		2.86E-03
FMS	ISP	cv_route_request	=trip_request+vehicle_identity	r	0.5	0.2	four times per vehicle per peak period	0	1354		6.27E-03
ImFrghD	FMS	From_Intermodal_Freight_Depot	=64	f	0.5	0.005	one in ten of vehicles interact once with an intermodal carrier	530	0		6.13E-05
ImFrghS	FMS	From_Intermodal_Freight_Shipper	=64	f	0.5	0.005	one in ten of vehicles interact once with an intermodal carrier	530	0		6.13E-05
ISP	FMS	cf_route	=cv_route_data+cv_route_number	f	0.5	0.1	twice per vehicle per peak period	3034	0		7.02E-03
ISP	FMS	cv_route	=cv_route_data+vehicle_identity	f	0.5	0.2	four times per vehicle per peak period	3154	0		1.46E-02
ISP	VS	advanced_fares_and_charges_response	=confirmation_flag+credit_identity+parking_lot_cost+stored_credit+transit_fare	f	0.1	1E-04	one user per 1000 users per peak period	234	0		5.42E-07
ISP	VS	advanced_tolls_and_fares_response	=confirmation_flag+credit_identity+stored_credit+toll_cost+transit_fare	f	0.1	1E-04	one user per 1000 users per peak period	234	0		5.42E-07
ISP	VS	advisory_data	=traffic_data_for_advisories+predicted_incidents_for_advisories+prediction_data_for_advisories+transit_services_for_advisories+transit_running_data_for_advisories	f	0.1	0.2	two sets of data per peak period	6146	0		2.85E-02
ISP	VS	yellow_pages_advisory_data	=yellow_pages_data_for_advisories+yellow_pages_cost+yellow_pages_dining_reservation_confirmation+yellow_pages_lodging_reservation_confirmation+yellow_pages_ticket_purchase_confirmation	f	0.1	0.01	one yellow pages advisory per 10 vehicles per peak period	10802	0		2.50E-03
LocData	VS	From_Location_Data_Source	=16	f	0.07	0.007	one in ten vehicles uses once per peak period	146	0		2.37E-05
PayInstr	VS	fpi_driver_vehicle_input_credit_identity	=credit_identity	f	0.1	1E-04	one vehicle per 1000 per peak period	178	0		4.12E-07
VS	EM	emergency_request_driver_details	=date+driver_personal_emergency_request+time	r	0.1	1E-04	one emergency per 1000 vehicles per peak period	0	282		6.53E-07
VS	EM	emergency_request_vehicle_details	=date+time+vehicle_emergency_request	r	0.1	1E-04	one emergency per 1000 vehicles per peak period	0	3354		7.76E-06

<b>CVO-Local, 2002, Urbansville</b>											
VS	ISP	advanced_fares_and_charges_request	=0.6*(advanced_fare_details)+0.6*(advanced_parking_lot_charges)	r	0.1	1E-04	one user per 1000 users per peak period	0	632.4		1.46E-06
VS	ISP	advanced_tolls_and_fares_request	=0.6*(advanced_fare_details)+0.6*(advanced_tolls)	r	0.1	1E-04	one user per 1000 users per peak period	0	642		1.49E-06
VS	ISP	advisory_data_request	=advisory_data_scope+vehicle_location_for_advisories+transit_route_number+transit_vehicle_identity	r	0.1	0.2	two requests per vehicle per peak period	0	290		1.34E-03
VS	ISP	yellow_pages_advisory_requests	=advisory_data_scope+vehicle_location_for_advisories+transit_route_number+transit_vehicle_identity+yellow_pages_dining_reservation+yellow_pages_lodging_reservation+yellow_pages_ticket_purchase	r	0.1	0.01	one yellow pages advisory per 10 vehicles per peak period	0	674		1.56E-04
VS	PayInstr	tpi_debited_driver_payment_at_vehicle	=4	r	0.1	1E-04	one vehicle per 1000 per peak period	0	50		1.16E-07
VS	PMS	advanced_parking_lot_charges_request	=credit_identity+parking_lot_identity+parking_space_details+stored_credit+vehicle_identity	r	0.1	5E-05	one user per 1000 users per peak period	0	514		5.95E-07
VS	PMS	parking_lot_payment_confirmation	=confirmation_flag	r	0.1	5E-05	one vehicle per 1000 per peak period	0	26		3.01E-08
<b>TOTALS (b/s/user):</b>									<b>3.68E-01</b>	<b>1.67E-01</b>	

## CVO-Long Haul, 2002, Urbansville

PA Source	PA Sink	Data Flow	Contents	Dir	Penetration	freq	Freq. Explain	Fwd bits	Rev bits	Fwd rate (b/s/u)	Rev rate (b/s/u)
CVAS	CVCS	cv_credentials_database_update	=cv_credentials_details+cv_credentials_status_code+cv_trip_classification_data	f	0.5	5E-05	one out of 1000 vehicles per peak period	482	0	5.58E-07	
CVAS	CVCS	cv_credentials_information_response	=cv_credentials_details+cv_credentials_status_code	f	0.5	0.005	one out of 10 vehicles	410	0	4.75E-05	
CVAS	CVCS	cv_safety_database_update	=cv_credentials_details+cv_roadside_safety_data	f	1	0.001	one out of 100 vehicles	410	0	9.49E-06	
CVAS	CVCS	cv_safety_information_response	=cv_credentials_details+cv_roadside_safety_data	f	1	0.001	one out of 100 vehicles are transmitted	410	0	9.49E-06	
CVAS	FMS	cf_clearance_enrollment_confirm	=confirmation_flag	f	0.5	0.05	once per vehicle per peak period	26	0	3.01E-05	
CVAS	FMS	cf_enrollment_information	=cv_route_number+cv_taxes_and_duties+route+route_type	f	0.5	0.025	one out of two vehicles require info. per peak period	3818	0	2.21E-03	
CVAS	FMS	cf_enrollment_payment_confirmation	=cv_route_number+cv_account_number+cv_amount_billed	f	0.5	0.05	once per vehicle per peak period	170	0	1.97E-04	
CVAS	FMS	cv_enrollment_information	=cv_route_number+cv_taxes_and_duties+route+route_type	f	0.5	0.025	one out of two vehicles require info. per peak period	3818	0	2.21E-03	
CVAS	FMS	cv_enrollment_payment_confirmation	=cv_account_number+cv_amount_billed+cv_driver_credit_identity+cv_route_number	f	0.5	0.05	once per vehicle per peak period	346	0	4.00E-04	
CVCS	CVAS	cv_credentials_information_request	=cv_credentials_details+cv_credentials_request_type+cv_credentials_request_identity+cv_roadside_facility_identity	r	0.5	0.005	request info on one in ten vehicles	0	554		6.41E-05
CVCS	CVAS	cv_roadside_daily_log	=cv_roadside_facility_identity+date++cv_archived_safety_data+cv_archived_inspection_data+cv_screening_record	r	0.5	5E-04	one report per 100 vehicles per peak period	0	3362		3.89E-05
CVCS	CVAS	cv_safety_information_request	=cv_credentials_details+cv_safety_information_request_identity+cv_safety_information_request_type+cv_roadside_facility_identity	r	1	0.01	request info on one in ten vehicles	0	554		1.28E-04
CVCS	CVAS	cv_update_safety_problems_list	=cv_credentials_details+cv_roadside_facility_identity+cv_roadside_safety_data	r	1	0.001	one out of 100 vehicles are on the list per peak period	0	538		1.25E-05

## CVO-Long Haul, 2002, Urbansville

CVS	FMS	cf_driver_route_instructions_request	=cv_driver_number+cv_route_number	r	0.5	0.5	average fleet vehicle requests one route per peak period	0	154		1.78E-03
CVS	FMS	cv_driver_enrollment_payment_request	=cv_account_number+cv_driver_credit_identity+cv_route_number	r	0.5	0.5	once per vehicle per peak period	0	330		3.82E-03
CVS	FMS	cv_driver_enrollment_request	=cv_cargo_class+cv_route_number+cv_vehicle_class+cv_weight_class	r	0.5	0.5	once per vehicle per peak period	0	98		1.13E-03
CVS	FMS	cv_driver_route_request	=trip_request+route_type	r	0.5	1	average vehicle requests 2 routes per peak period	0	1234		2.86E-02
CVS	FMS	cv_driver_storage_request	=cv_route_number	r	0.5	0.05	one in ten vehicles per peak period	0	26		3.01E-05
CVS	FMS	cv_static_route_data	=256	r	0.5	1	two routes per vehicle per peak period	0	2066		4.78E-02
EM	FMS	cf_hazmat_request	=16	f	0.1	1E-05	once per 1000 vehicles per peak period	146	0	3.38E-08	
EM	VS	emergency_request_driver_acknowledge	=1	f	0.1	1E-04	one emergency per 1000 vehicles per peak period	26	0	6.02E-08	
EM	VS	emergency_request_vehicle_acknowledge	=1	f	0.1	1E-04	one emergency per 1000 vehicles per peak period	26	0	6.02E-08	
FMS	CVAS	cf_enroll_clearance_data	=cv_credentials_details	r	0.5	0.05	once per vehicle per peak period	0	402		4.65E-04
FMS	CVAS	cf_enrollment_payment_request	=cf_manager_credit_identity+cv_account_number+cv_route_number+1.5*(cv_taxes_and_duties)	r	0.5	0.05	once per vehicle per peak period	0	414		4.79E-04
FMS	CVAS	cf_enrollment_request	=cv_route_data+cv_credentials_details+cv_route_number+cv_trip_classification_data+route_type	r	0.5	0.05	once per vehicle per peak period	0	3498		4.05E-03
FMS	CVAS	cv_enrollment_payment_request	=cv_account_number+cv_driver_credit_identity+cv_route_number+1.5*(cv_taxes_and_duties)	r	0.5	0.05	once per vehicle per peak period	0	414		4.79E-04
FMS	CVAS	cv_enrollment_request	=cv_route_data+cv_credentials_details+cv_trip_classification_data+cv_route_number+route_type	r	0.5	0.05	once per vehicle per peak period	0	3498		4.05E-03
FMS	CVS	cf_driver_route_instructions	=cf_driver_route+cf_driver_load_details	f	0.5	0.5	once per vehicle per peak period	5082	0	5.88E-02	

## CVO-Long Haul, 2002, Urbansville

FMS	CVS	cv_driver_enrollment_in formation	=cv_route_number+cv_taxes_and_duties	f	0.5	0.25	one out of two vehicles require info. per peak period	82	0	4.75E-04	
FMS	CVS	cv_driver_enrollment_p ayment_confirmation	=cv_account_number+cv_amount_billed+cv_driver _credit_identity+cv_route_number	f	0.5	0.5	once per vehicle per peak period	346	0	4.00E-03	
FMS	CVS	cv_driver_route_data	=cv_route_data+route_type+cv_route_number	f	0.5	1	average vehicle requests two routes per peak period	3042	0	7.04E-02	
FMS	CVS	cv_static_route_request	=origin+destination+departure_time+desired_arrival _time+preferences+constraints	f	0.5	1	average vehicle requests two routes per peak period	1226	0	2.84E-02	
FMS	EM	cf_hazmat_route_inform ation	=cv_route_number+route	r	0.1	1E-05	once per 1000 vehicles per peak period	0	3754		8.69E-07
FMS	EM	cf_hazmat_vehicle_infor mation	=28	r	0.1	1E-05	once per 1000 vehicles per peak period	0	242		5.60E-08
FMS	ImFrgh tD	To_Intermodal_Freight_ Depot	=64	r	0.5	0.005	one in ten vehicles interacts once with an intermodal carrier	0	530		6.13E-05
FMS	ImFrgh tS	To_Intermodal_Freight_ Shipper	=64	r	0.5	0.005	one in ten vehicles interacts once with an intermodal carrier	0	530		6.13E-05
FMS	ISP	cf_route_request	=trip_request+cv_route_number	r	0.5	0.05	once per vehicle per peak period	0	1234		1.43E-03
FMS	ISP	cv_route_request	=trip_request+vehicle_identity	r	0.5	0.1	twice per vehicle per peak period	0	1354		3.13E-03
FMS	PayInstr	tpi_debited_commercial_ _manager_payment	=4	r	0.5	0.05	once per enrollment	0	50		5.79E-05
ImFrgh tD	FMS	From_Intermodal_Freig ht_Depot	=64	f	0.5	0.005	one in ten vehicles interacts once with an intermodal carrier	530	0	6.13E-05	
ImFrgh tS	FMS	From_Intermodal_Freig ht_Shipper	=64	f	0.5	0.005	one in ten vehicles interacts once with an intermodal carrier	530	0	6.13E-05	
ISP	FMS	cf_route	=cv_route_data+cv_route_number	f	0.5	0.05	once per vehicle per peak period	3034	0	3.51E-03	
ISP	FMS	cv_route	=cv_route_data+vehicle_identity	f	0.5	0.1	twice per vehicle per peak period	3154	0	7.30E-03	

## CVO-Long Haul, 2002, Urbansville

ISP	VS	advanced_fares_and_charges_response	=confirmation_flag+credit_identity+parking_lot_cost+stored_credit+transit_fare	f	0.1	1E-04	one user per 1000 users per peak period	234	0	5.42E-07	
ISP	VS	advanced_tolls_and_fares_response	=confirmation_flag+credit_identity+stored_credit+toll_cost+transit_fare	f	0.1	1E-04	one user per 1000 users per peak period	234	0	5.42E-07	
ISP	VS	advisory_data	=traffic_data_for_advisories+predicted_incidents_for_advisories+prediction_data_for_advisories+transit_services_for_advisories+transit_running_data_for_advisories	f	0.1	0.1	one set of data per peak period	6146	0	1.42E-02	
ISP	VS	yellow_pages_advisory_data	=yellow_pages_data_for_advisories+yellow_pages_cost+yellow_pages_dining_reservation_confirmation+yellow_pages_lodging_reservation_confirmation+yellow_pages_ticket_purchase_confirmation	f	0.1	0.01	one yellow pages advisory per 10 vehicles per peak period	10802	0	2.50E-03	
LocData	VS	From_Location_Data_Source	=16	f	0.07	0.007	one in ten vehicles uses once per peak period	146	0	2.37E-05	
PayInstr	FMS	fpi_commercial_manager_input_credit_identity	=12	f	0.5	0.05	once per enrollment = once per cv per peak period	114	0	1.32E-04	
PayInstr	VS	fpi_driver_vehicle_input_credit_identity	=credit_identity	f	0.1	1E-04	one vehicle per 1000 per peak period	178	0	4.12E-07	
VS	EM	emergency_request_driver_details	=date+driver_personal_emergency_request+time	r	0.1	1E-04	one emergency per 1000 vehicles per peak period	0	282		6.53E-07
VS	EM	emergency_request_vehicle_details	=date+time+vehicle_emergency_request	r	0.1	1E-04	one emergency per 1000 vehicles per peak period	0	3354		7.76E-06
VS	ISP	advanced_fares_and_charges_request	=0.6*(advanced_fare_details)+0.6*(advanced_parking_lot_charges)	r	0.1	1E-04	one user per 1000 users per peak period	0	632.4		1.46E-06
VS	ISP	advanced_tolls_and_fares_request	=0.6*(advanced_fare_details)+0.6*(advanced_tolls)	r	0.1	1E-04	one user per 1000 users per peak period	0	642		1.49E-06
VS	ISP	advisory_data_request	=advisory_data_scope+vehicle_location_for_advisories+transit_route_number+transit_vehicle_identity	r	0.1	0.2	two requests per vehicle per peak period	0	290		1.34E-03
VS	ISP	vehicle_guidance_route_accepted	=route_identity	r	0.07	0.14	two acceptances per peak period	0	34		1.10E-04



## CVO-Long Haul, 2002, Urbansville

VS	ISP	yellow_pages_advisory_requests	=advisory_data_scope+vehicle_location_for_advisories+transit_route_number+transit_vehicle_identity+yellow_pages_dining_reservation+yellow_pages_lodging_reservation+yellow_pages_ticket_purchase	r	0.1	0.01	one yellow pages advisory per 10 vehicles per peak period	0	674		1.56E-04
VS	PayInstr	tpi_debited_driver_payment_at_vehicle	=4	r	0.1	1E-04	one vehicle per 1000 per peak period	0	50		1.16E-07
VS	PMS	advanced_parking_lot_charges_request	=credit_identity+parking_lot_identity+parking_space_details+stored_credit+vehicle_identity	r	0.1	5E-05	one user per 1000 users per peak period	0	514		5.95E-07
VS	PMS	parking_lot_payment_confirmation	=confirmation_flag	r	0.1	5E-05	one vehicle per 1000 per peak period	0	26		3.01E-08
<b>TOTALS (b/s/user):</b>									<b>1.95E-01</b>	<b>9.93E-02</b>	

## Transit, 2002, Urbansville

PA Source	PA Sink	Data Flow	Contents	Dire c.	Pene tration	freq	Freq. Explain	Fwd bits	Rev bits	Fwd rate (b/s/u)	Rev rate (b/s/u)
ISP	RTS	advanced_tolls_and_charges_roadside_confirm	=advanced_charges_confirm+advanced_tolls_confirm+confirmation_flag	f	0.1	3E-04	one use per 1000 transit users per peak period, or 0.032/transit vehicle	426	0	2.91E-06	
ISP	RTS	traveler_payment_confirmation	=advanced_tolls_confirm+advanced_fares_confirm+advanced_parking_lot_charges_confirm+credit_identity+kiosk_identity+stored_credit+traveler_total_trip_cost	f	0.1	3E-04	one use per 1000 transit users per peak period, or 0.032/transit vehicle	666	0	4.55E-06	
ISP	RTS	traveler_transaction_confirmation	=credit_identity+kiosk_identity+transaction_number+yellow_pages_cost+yellow_pages_lodging_reservation_confirmation+yellow_pages_dining_reservation_confirmation+yellow_pages_ticket_purchase_confirmation	f	0.1	3E-04	one use per 1000 transit users per peak period, or 0.032/transit vehicle	498	0	3.41E-06	
ISP	RTS	traveler_yellow_pages_data	=kiosk_identity+0.01*(yellow_pages_general_information+yellow_pages_specific_information+yellow_pages_transaction_information)	f	0.1	3E-04	one use per 1000 transit users per peak period, or 0.032/transit vehicle	987.7	0	6.75E-06	

## Transit, 2002, Urbansville

PayInstr	RTS	fpi_confirm_fare_payment_at_roadside	=confirmation_flag	f	0.1	0.064	one in five transit users = 6.4 per transit vehicle per peak period	26	0	3.56E-05	
PayInstr	RTS	fpi_transit_roadside_tag_data	=credit_identity	f	0.1	3E-04	one data set for 1000 users = 0.032 uses per transit vehicle per peak period	178	0	1.22E-06	
PayInstr	RTS	fpi_transit_user_roadside_input_credit_identity	=credit_identity	f	0.1	3E-04	one data set for 1000 users = 0.032 uses per transit vehicle per peak period	178	0	1.22E-06	
PayInstr	RTS	fpi_traveler_roadside_input_credit_identity	=credit_identity	f	0.1	3E-04	one data set for 1000 users = 0.032 uses per transit vehicle per peak period	178	0	1.22E-06	
PayInstr	TRVS	fpi_confirm_fare_payment_on_transit_vehicle	=confirmation_flag	f	1	32	average of one use per transit user per peak period = 32 per transit vehicle	26	0	1.78E-02	
PayInstr	TRVS	fpi_transit_vehicle_tag_data	=credit_identity	f	1	0.032	one data set for 1000 users = 0.032 uses per transit vehicle per peak period	178	0	1.22E-04	
RTS	EM	emergency_request_kiosk_traveler_details	=date+time+traveler_personal_emergency_request	r	1	0.003	one emergency per 1000 transit users per peak period, or 0.032/transit vehicle	0	370		2.53E-05
RTS	ISP	advanced_tolls_and_charges_roadside_request	=0.6*(advanced_charges)+0.6*(advanced_tolls)	r	0.1	3E-04	one use per 1000 transit users per peak period, or 0.032/transit vehicle	0	738		5.05E-06
RTS	ISP	traffic_data_kiosk_request	=kiosk_identity+traffic_data_request	r	0.1	0.32	average of one use per transit user per peak period = 32 per transit vehicle	0	98		6.70E-04
RTS	ISP	transit_deviation_kiosk_request	=kiosk_identity+transit_vehicle_deviation_request	r	0.1	0.064	one in five transit users = 6.4 per transit vehicle per peak period	0	66		9.03E-05

## Transit, 2002, Urbansville

RTS	ISP	traveler_current_conditi on_request	=kiosk_identity	r	0.1	0.32	average of one use per transit user per peak period = 32 per transit vehicle	0	58		3.97E-04
RTS	ISP	traveler_payment_infor mation	=credit_identity+kiosk_identity+parking_space_deta ils+ride_segments+stored_credit+toll_segments	r	0.1	3E-04	one use per 1000 transit users per peak period, or 0.032/transit vehicle	0	978		6.69E-06
RTS	ISP	traveler_transaction_req uest	=yellow_pages_dining_reservation+yellow_pages_l odging_reservation+yellow_pages_ticket_purchase	r	0.1	3E-04	one use per 1000 transit users per peak period, or 0.032/transit vehicle	0	402		2.75E-06
RTS	ISP	traveler_trip_confirmatio n	=paratransit_service_confirmation+traveler_identity +traveler_rideshare_confirmation	r	0.1	3E-04	one use per 1000 transit users per peak period, or 0.032/transit vehicle	0	858		5.87E-06
RTS	ISP	traveler_trip_request	=trip_request+traveler_identity+traveler_rideshare_r equest	r	0.1	3E-04	one use per 1000 transit users per peak period, or 0.032/transit vehicle	0	1434		9.81E-06
RTS	ISP	traveler_yellow_pages_i nformation_request	=1	r	0.1	3E-04	one use per 1000 transit users per peak period, or 0.032/transit vehicle	0	26		1.78E-07
RTS	PayInstr	tpi_debited_fare_payme nt_at_roadside	=4	r	0.1	0.064	one in five transit users = 6.4 per transit vehicle per peak period	0	50		6.84E-05
RTS	PayInstr	tpi_debited_transit_user _payment_at_roadside	=4	r	0.1	0.032	one in ten transit users = 3.2 per transit vehicle per peak period	0	50		3.42E-05
RTS	PayInstr	tpi_debited_traveler_pa yment_at_roadside	=4	r	0.1	3E-04	one data set for 1000 users = 0.032 uses per transit vehicle per peak period	0	50		3.42E-07
RTS	PayInstr	tpi_request_fare_payme nt_at_roadside	=2	r	0.1	3E-04	one data set for 1000 users = 0.032 uses per transit vehicle per peak period	0	34		2.32E-07
TRMS	TRVS	approved_corrective_pl an	=transit_route_corrections+transit_changes_in_stop s+transit_changes_in_speed	f	1	0.1	one corrective message per ten vehicles per peak period	8210	0	1.75E-02	

## Transit, 2002, Urbansville

TRMS	TRVS	confirm_vehicle_fare_payment	=confirmation_flag	f	1	32	average of one use per transit user per peak period = 32 per transit vehicle	26	0	1.78E-02
TRMS	TRVS	other_services_vehicle_response	=traveler_identity+credit_identity+other_services_data	f	0.1	0.003	one data set for 1000 users = 0.032 uses per transit vehicle per peak period	2418	0	1.65E-04
TRMS	TRVS	paratransit_transit_driver_instructions	=128	f	1	13	dispatch message every 15 min. during peak period=48/4(ratio of paratr/tr veh)	1042	0	2.89E-01
TRMS	TRVS	request_transit_user_image	=8	f	1	0.032	one image for 1000 users = 0.032 uses per transit vehicle per peak period	82	0	5.61E-05
TRMS	TRVS	transit_operator_request_acknowledge	=2	f	1	0.032	one data set for 1000 users = 0.032 uses per transit vehicle per peak period	34	0	2.32E-05
TRMS	TRVS	transit_services_for_corrections	=list_size+1*(2/NUM_TRANSIT_ROUTES)*(transit_services)	f	1	13	one correction per hour during the peak period	17260	0	4.79E+00
TRMS	TRVS	transit_services_for_eta	=transit_route_number+transit_route_segment_list+transit_route_stop_list	f	1	52	update every 15 minutes during the peak period	7786	0	8.65E+00
TRMS	TRVS	transit_services_for_vehicle_fares	=transit_route_fare_data	f	1	1	update daily during peak period	16826	0	3.60E-01
TRMS	TRVS	transit_vehicle_advanced_payment_response	=advanced_charges_confirm+advanced_tolls_confirm+confirmation_flag+transit_vehicle_identity	f	1	0.032	one data set for 1000 users = 0.032 uses per transit vehicle per peak period	554	0	3.79E-04
TRMS	TRVS	transit_vehicle_fare_data	=transit_fares	f	1	1	updated once per peak period per transit vehicle	922	0	1.97E-02
TRMS	TRVS	transit_vehicle_fare_payment_debited	=confirmation_flag	f	1	32	average of one use per transit user per peak period = 32 per transit vehicle	26	0	1.78E-02
TRMS	TRVS	transit_vehicle_fare_payment_request	=transit_fare	f	1	32	average of one use per transit user per peak period = 32 per transit vehicle	34	0	2.32E-02

# Transit, 2002, Urbansville

TRVS	PayInstr	tpi_debited_payment_on_transit_vehicle	=4	f	1	32	average of one use per transit user per peak period = 32 per transit vehicle	50	0	3.42E-02	
TRVS	PayInstr	tpi_request_fare_payment_on_transit_vehicle	=2	f	1	32	average of one use per transit user per peak period = 32 per transit vehicle	34	0	2.32E-02	
TRVS	TRMS	other_services_vehicle_request	=traveler_identity+credit_identity+other_services_data	r	0.1	0.003	one data set for 1000 users = 0.032 uses per transit vehicle per peak period	0	2418		1.65E-04
TRVS	TRMS	paratransit_transit_vehicle_availability	=1	r	1	13	avail. message every 15 min. during peak period=48/4(ratio of paratr/tr veh)	0	26		7.22E-03
TRVS	TRMS	request_vehicle_fare_payment	=credit_identity+transit_fare+transit_route_number+transit_route_segment_number+transit_route_use_time+transit_user_category+traveler_identity	r	1	32	average of one use per peak period per transit user = 32 per transit vehicle	0	466		3.19E-01
TRVS	TRMS	transit_conditions_request	=2	r	1	0.1	one corrective message per ten vehicles per peak period	0	34		7.26E-05
TRVS	TRMS	transit_emergency_details	=transit_driver_emergency_request+transit_user_emergency_request+transit_vehicle_location	r	1	0.003	emergency for one in 10000 transit users=0.0032 per transit vehicle per peak	0	282		1.93E-05
TRVS	TRMS	transit_emergency_information	=transit_driver_emergency_request+transit_user_emergency_request+transit_vehicle_location	r	1	0.003	emergency for one in 10000 transit users=0.0032 per transit vehicle per peak	0	282		1.93E-05
TRVS	TRMS	transit_operator_emergency_request	=128	r	1	0.003	emergency for one in 10000 transit users=0.0032 per transit vehicle per peak	0	1042		7.12E-05
TRVS	TRMS	transit_services_for_eta_request	=transit_vehicle_identity+transit_route_number+transit_route_schedule_number	r	1	3.2	average of one use per 10 transit users per peak period=3.2 per transit vehicle	0	186		1.27E-02

<b>Transit, 2002, Urbansville</b>											
TRVS	TRMS	transit_user_vehicle_image	=JPEG*(ftu_transit_user_vehicle_image)	r	1	0.011	20 images per metro area per peak period=20/1788 transit vehicles	0	73746		1.73E-02
TRVS	TRMS	transit_vehicle_advanced_payment_request	=advanced_charges+advanced_tolls+transit_vehicle_location	r	0.1	0.003	one data set for 1000 users = 0.032 uses per transit vehicle per peak period	0	1450		9.91E-05
TRVS	TRMS	transit_vehicle_arrival_conditions	=128	r	1	13	updated every 60 minutes during the peak period	0	1042		2.89E-01
TRVS	TRMS	transit_vehicle_collected_trip_data	=transit_vehicle_passenger_loading+transit_vehicle_running_times	r	1	13	every hour for each transit vehicle per peak period	0	1826		5.07E-01
TRVS	TRMS	transit_vehicle_deviations_from_schedule	=32	r	1	52	update every 15 minutes during the peak period	0	274		3.04E-01
TRVS	TRMS	transit_vehicle_eta	=transit_vehicle_identity+transit_vehicle_time+transit_route_number	r	1	156	updated every 5 minutes during the peak period	0	234		7.80E-01
TRVS	TRMS	transit_vehicle_fare_payment_confirmation	=confirmation_flag	r	1	32	average of one use per transit user per peak period = 32 per transit vehicle	0	26		1.78E-02
TRVS	TRMS	transit_vehicle_location	=transit_vehicle_identity+transit_vehicle_location_data	r	1	52	updated every 15 minutes during the peak period	0	250		2.78E-01
TRVS	TRMS	transit_vehicle_location_for_deviation	=transit_vehicle_identity+transit_vehicle_location_data	r	1	52	updated every 15 minutes during the peak period	0	250		2.78E-01
TRVS	TRMS	transit_vehicle_location_for_store	=transit_vehicle_identity+transit_vehicle_location_data	r	1	13	updated every 60 minutes during the peak period	0	250		6.94E-02
TRVS	TRMS	transit_vehicle_passenger_data	=transit_passenger_numbers+transit_route_number+transit_route_segment_number+transit_route_use_time+transit_user_category+transit_vehicle_identity	r	1	52	update every 15 minutes during the peak period	0	242		2.69E-01
TRVS	TRMS	transit_vehicle_schedule_deviation	=32	r	1	52	updated every 15 minutes during the peak period	0	274		3.04E-01
<b>TOTALS (b/s/user):</b>									<b>1.43E+01</b>	<b>3.45E+00</b>	

## Emergency Management, 2002, Urbansville

PA Source	PA Sink	Data Flow	Contents	Dire c.	Pene trati on	freq	Freq. Explain	Fwd bits	Rev bits	Fwd rate (b/s/u)	Rev rate (b/s/u)
EM	EVS	emergency_vehicle_driver_outputs	=128	f	1	13	average one driver output per vehicle per hour during the peak period	1042	0	2.89E-01	
EVS	EM	emergency_driver_dispatch_acknowledge	=1	r	1	26	average one dispatch acknowledge per vehicle per 1/2 hour during the peak period	0	26		1.44E-02
EVS	EM	emergency_driver_statuses_update	=16	r	1	26	average one status update per vehicle per 1/2 hour during the peak period	0	146		8.11E-02
EVS	EM	emergency_vehicle_driver_inputs	=64	r	1	13	average one driver input per vehicle per hour during the peak period	0	530		1.47E-01
<b>TOTALS (b/s/user):</b>										<b>2.89E-01</b>	<b>2.43E-01</b>

## Probes, 2002, Urbansville

PA Source	PA Sink	Data Flow	Contents	Dire c.	Pene trati on	freq	Freq. Explain	Fwd bits	Rev bits	Fwd rate (b/s/u)	Rev rate (b/s/u)
VS	ISP	vehicle_guidance_probe_data	=route_segment_identity+vehicle_identity	r	1	12	average of 12 probe reports per vehicle per peak period	0	314		1.74E-01
<b>TOTALS (b/s/user):</b>										<b>0.00E+00</b>	<b>1.74E-01</b>

## Private Vehicle, 2002, Thruville

PA Source	PA Sink	Data Flow	Contents	Dir ec.	Penetration	freq	Freq. Explain	Fwd bits	Rev bits	Fwd rate (b/s/u)	Rev rate (b/s/u)
EM	VS	emergency_request_driver_acknowledge	=1	f	0.1	1E-04	one emergency per 1000 vehicles per peak period	26	0	1.20E-07	
EM	VS	emergency_request_vehicle_acknowledge	=1	f	0.1	1E-04	one emergency per 1000 vehicles per peak period	26	0	1.20E-07	
LocData	VS	From_Location_Data_Source	=16	f	0.07	0.007	one in ten vs uses per peak period	146	0	4.73E-05	
PayInstr	VS	fpi_transit_user_vehicle_input_credit_identity	=credit_identity	f	1	1E-04	one in 10000 vehicles uses this flow per peak period	178	0	8.24E-07	
VS	EM	emergency_request_driver_details	=date+driver_personal_emergency_request+time	r	0.1	1E-04	one emergency per 1000 vehicles per peak period	0	282		1.31E-06
VS	EM	emergency_request_vehicle_details	=date+time+vehicle_emergency_request	r	0.1	1E-04	one emergency per 1000 vehicles per peak period	0	3354		1.55E-05
VS	ISP	advisory_data_request	=advisory_data_scope+vehicle_location_for_advisories+transit_route_number+transit_vehicle_identity	r	0.1	0.1	one request per vehicle per peak period	0	290		1.34E-03
VS	ISP	vehicle_guidance_route_accepted	=route_identity	r	0.07	0.14	two acceptances per peak period	0	34		2.20E-04
<b>TOTALS (b/s/user):</b>										<b>4.84E-05</b>	<b>1.58E-03</b>



## Traveler, 2002, Thruville

PA Source	PA Sink	Data Flow	Contents	Dir c.	Penetration	freq	Freq. Explain	Fwd bits	Rev bits	Fwd rate (b/s/u)	Rev rate (b/s/u)
EM	PIAS	emergency_request_personal_traveler_acknowledge	=confirmation_flag	f	0.1	3E-05	one emergency per 2000 users in peak period	26	0	3.01E-08	
ISP	PIAS	transit_deviations_for_portables	=traveler_identity+list_size+TRANSIT_SEGS*(transit_vehicle_identity+transit_vehicle_achieved_time+transit_route_segment_number)	f	0.1	3E-04	one request per 20 pias per peak period	3578	0	4.14E-05	
ISP	PIAS	traveler_guidance_route	=route_identity+traveler_route+traveler_identity	f	0.07	0.004	one route per day per pias	18306	0	2.97E-03	
LocData	PIAS	From_Location_Data_Source	=16	f	0.07	0.007	one in ten pias uses per peak period	146	0	4.73E-05	
PIAS	EM	emergency_request_personal_traveler_details	=date+time+traveler_personal_emergency_request	r	0.1	3E-05	one emergency per 2000 users in peak period	0	370		4.28E-07
PIAS	ISP	traffic_data_portables_request	=traffic_data_request+traveler_identity	r	0.1	0.05	one request per pias per peak period	0	250		5.79E-04
PIAS	ISP	transit_deviations_portables_request	=traveler_identity+transit_vehicle_deviation_request+transit_route_number	r	0.1	0.003	one request per 20 pias per peak period	0	250		2.89E-05
<b>TOTALS (b/s/user):</b>										<b>3.06E-03</b>	<b>6.08E-04</b>

## CVO-Local, 2002, Thruville

PA Source	PA Sink	Data Flow	Contents	Dir c.	Penetration	freq	Freq. Explain	Fwd bits	Rev bits	Fwd rate (b/s/u)	Rev rate (b/s/u)
CVS	FMS	cf_driver_route_instructions_request	=cv_driver_number+cv_route_number	r	0.5	1	average fleet vehicle requests two routes per peak period	0	154		3.56E-03
CVS	FMS	cv_driver_route_request	=trip_request+route_type	r	0.5	2	average vehicle requests 4 routes per peak period	0	1234		5.71E-02
CVS	FMS	cv_driver_storage_request	=cv_route_number	r	0.5	0.05	one in ten vehicles per peak period	0	26		3.01E-05
CVS	FMS	cv_static_route_data	=256	r	0.5	2	four routes per vehicle per peak period	0	2066		9.56E-02
EM	FMS	cf_hazmat_request	=16	f	0.1	1E-05	once per 1000 vehicles per peak period	146	0	3.38E-08	
EM	VS	emergency_request_driver_acknowledge	=1	f	0.1	1E-04	one emergency per 1000 vehicles per peak period	26	0	6.02E-08	
EM	VS	emergency_request_vehicle_acknowledge	=1	f	0.1	1E-04	one emergency per 1000 vehicles per peak period	26	0	6.02E-08	
FMS	CVS	cf_driver_route_instructions	=cf_driver_route+cf_driver_load_details	f	0.5	1	twice per vehicle per peak period	5082	0	1.18E-01	
FMS	CVS	cv_driver_route_data	=cv_route_data+route_type+cv_route_number	f	0.5	2	average vehicle requests four routes per peak period	3042	0	1.41E-01	
FMS	CVS	cv_static_route_request	=origin+destination+departure_time+desired_arrival_time+preferences+constraints	f	0.5	2	average vehicle requests four routes per peak period	1226	0	5.68E-02	
FMS	EM	cf_hazmat_route_information	=cv_route_number+route	r	0.1	1E-05	once per 1000 vehicles per peak period	0	3754		8.69E-07
FMS	EM	cf_hazmat_vehicle_information	=28	r	0.1	1E-05	once per 1000 vehicles per peak period	0	242		5.60E-08
FMS	ImFrghD	To_Intermodal_Freight_Depot	=64	r	0.5	0.005	one in ten of vehicles interact once with an intermodal carrier	0	530		6.13E-05
FMS	ImFrghS	To_Intermodal_Freight_Shipper	=64	r	0.5	0.005	one in ten of vehicles interact once with an intermodal carrier	0	530		6.13E-05

## CVO-Local, 2002, Thruville

FMS	ISP	cf_route_request	=trip_request+cv_route_number	r	0.5	0.1	twice per vehicle per peak period	0	1234		2.86E-03	
FMS	ISP	cv_route_request	=trip_request+vehicle_identity	r	0.5	0.2	four times per vehicle per peak period	0	1354		6.27E-03	
ImFrghtD	FMS	From_Intermodal_Freight_Depot	=64	f	0.5	0.005	one in ten of vehicles interact once with an intermodal carrier	530	0		6.13E-05	
ImFrghtS	FMS	From_Intermodal_Freight_Shipper	=64	f	0.5	0.005	one in ten of vehicles interact once with an intermodal carrier	530	0		6.13E-05	
ISP	FMS	cf_route	=cv_route_data+cv_route_number	f	0.5	0.1	twice per vehicle per peak period	3034	0		7.02E-03	
ISP	FMS	cv_route	=cv_route_data+vehicle_identity	f	0.5	0.2	four times per vehicle per peak period	3154	0		1.46E-02	
LocData	VS	From_Location_Data_Source	=16	f	0.07	0.007	one in ten vehicles uses once per peak period	146	0		2.37E-05	
VS	EM	emergency_request_driver_details	=date+driver_personal_emergency_request+time	r	0.1	1E-04	one emergency per 1000 vehicles per peak period	0	282		6.53E-07	
VS	EM	emergency_request_vehicle_details	=date+time+vehicle_emergency_request	r	0.1	1E-04	one emergency per 1000 vehicles per peak period	0	3354		7.76E-06	
VS	ISP	advisory_data_request	=advisory_data_scope+vehicle_location_for_advisories+transit_route_number+transit_vehicle_identity	r	0.1	0.2	two requests per vehicle per peak period	0	290		1.34E-03	
<b>TOTALS (b/s/user):</b>											<b>3.37E-01</b>	<b>1.67E-01</b>

## CVO-Long Haul, 2002, Thruville

PA Source	PA Sink	Data Flow	Contents	Dir	Penetration	freq	Freq. Explain	Fwd bits	Rev bits	Fwd rate (b/s/u)	Rev rate (b/s/u)
CVAS	CVCS	cv_credentials_database_update	=cv_credentials_details+cv_credentials_status_code+cv_trip_classification_data	f	0.5	5E-05	one out of 1000 vehicles per peak period	482	0	5.58E-07	
CVAS	CVCS	cv_credentials_information_response	=cv_credentials_details+cv_credentials_status_code	f	0.5	0.005	one out of 10 vehicles	410	0	4.75E-05	
CVAS	CVCS	cv_safety_database_update	=cv_credentials_details+cv_roadside_safety_data	f	1	0.001	one out of 100 vehicles	410	0	9.49E-06	
CVAS	CVCS	cv_safety_information_response	=cv_credentials_details+cv_roadside_safety_data	f	1	0.001	one out of 100 vehicles are transmitted	410	0	9.49E-06	
CVAS	FMS	cf_clearance_enrollment_confirm	=confirmation_flag	f	0.5	0.05	once per vehicle per peak period	26	0	3.01E-05	
CVAS	FMS	cf_enrollment_information	=cv_route_number+cv_taxes_and_duties+route+route_type	f	0.5	0.025	one out of two vehicles require info. per peak period	3818	0	2.21E-03	
CVAS	FMS	cf_enrollment_payment_confirmation	=cv_route_number+cv_account_number+cv_amount_billed	f	0.5	0.05	once per vehicle per peak period	170	0	1.97E-04	
CVAS	FMS	cv_enrollment_information	=cv_route_number+cv_taxes_and_duties+route+route_type	f	0.5	0.025	one out of two vehicles require info. per peak period	3818	0	2.21E-03	
CVAS	FMS	cv_enrollment_payment_confirmation	=cv_account_number+cv_amount_billed+cv_driver_credit_identity+cv_route_number	f	0.5	0.05	once per vehicle per peak period	346	0	4.00E-04	
CVCS	CVAS	cv_credentials_information_request	=cv_credentials_details+cv_credentials_request_type+cv_credentials_request_identity+cv_roadside_facility_identity	r	0.5	0.005	request info on one in ten vehicles	0	554		6.41E-05
CVCS	CVAS	cv_roadside_daily_log	=cv_roadside_facility_identity+date++cv_archived_safety_data+cv_archived_inspection_data+cv_screening_record	r	0.5	5E-04	one report per 100 vehicles per peak period	0	3362		3.89E-05
CVCS	CVAS	cv_safety_information_request	=cv_credentials_details+cv_safety_information_request_identity+cv_safety_information_request_type+cv_roadside_facility_identity	r	1	0.01	request info on one in ten vehicles	0	554		1.28E-04
CVCS	CVAS	cv_update_safety_problems_list	=cv_credentials_details+cv_roadside_facility_identity+cv_roadside_safety_data	r	1	0.001	one out of 100 vehicles are on the list per peak period	0	538		1.25E-05

## CVO-Long Haul, 2002, Thruville

CVS	FMS	cf_driver_route_instructions_request	=cv_driver_number+cv_route_number	r	0.5	0.5	average fleet vehicle requests one route per peak period	0	154		1.78E-03
CVS	FMS	cv_driver_enrollment_payment_request	=cv_account_number+cv_driver_credit_identity+cv_route_number	r	0.5	0.5	once per vehicle per peak period	0	330		3.82E-03
CVS	FMS	cv_driver_enrollment_request	=cv_cargo_class+cv_route_number+cv_vehicle_class+cv_weight_class	r	0.5	0.5	once per vehicle per peak period	0	98		1.13E-03
CVS	FMS	cv_driver_route_request	=trip_request+route_type	r	0.5	1	average vehicle requests 2 routes per peak period	0	1234		2.86E-02
CVS	FMS	cv_driver_storage_request	=cv_route_number	r	0.5	0.05	one in ten vehicles per peak period	0	26		3.01E-05
CVS	FMS	cv_static_route_data	=256	r	0.5	1	two routes per vehicle per peak period	0	2066		4.78E-02
EM	FMS	cf_hazmat_request	=16	f	0.1	1E-05	once per 1000 vehicles per peak period	146	0	3.38E-08	
EM	VS	emergency_request_driver_acknowledge	=1	f	0.1	1E-04	one emergency per 1000 vehicles per peak period	26	0	6.02E-08	
EM	VS	emergency_request_vehicle_acknowledge	=1	f	0.1	1E-04	one emergency per 1000 vehicles per peak period	26	0	6.02E-08	
FMS	CVAS	cf_enroll_clearance_data	=cv_credentials_details	r	0.5	0.05	once per vehicle per peak period	0	402		4.65E-04
FMS	CVAS	cf_enrollment_payment_request	=cf_manager_credit_identity+cv_account_number+cv_route_number+1.5*(cv_taxes_and_duties)	r	0.5	0.05	once per vehicle per peak period	0	414		4.79E-04
FMS	CVAS	cf_enrollment_request	=cv_route_data+cv_credentials_details+cv_route_number+cv_trip_classification_data+route_type	r	0.5	0.05	once per vehicle per peak period	0	3498		4.05E-03
FMS	CVAS	cv_enrollment_payment_request	=cv_account_number+cv_driver_credit_identity+cv_route_number+1.5*(cv_taxes_and_duties)	r	0.5	0.05	once per vehicle per peak period	0	414		4.79E-04
FMS	CVAS	cv_enrollment_request	=cv_route_data+cv_credentials_details+cv_trip_classification_data+cv_route_number+route_type	r	0.5	0.05	once per vehicle per peak period	0	3498		4.05E-03
FMS	CVS	cf_driver_route_instructions	=cf_driver_route+cf_driver_load_details	f	0.5	0.5	once per vehicle per peak period	5082	0	5.88E-02	

## CVO-Long Haul, 2002, Thruville

FMS	CVS	cv_driver_enrollment_in formation	=cv_route_number+cv_taxes_and_duties	f	0.5	0.25	one out of two vehicles require info. per peak period	82	0	4.75E-04	
FMS	CVS	cv_driver_enrollment_p ayment_confirmation	=cv_account_number+cv_amount_billed+cv_driver _credit_identity+cv_route_number	f	0.5	0.5	once per vehicle per peak period	346	0	4.00E-03	
FMS	CVS	cv_driver_route_data	=cv_route_data+route_type+cv_route_number	f	0.5	1	average vehicle requests two routes per peak period	3042	0	7.04E-02	
FMS	CVS	cv_static_route_request	=origin+destination+departure_time+desired_arrival _time+preferences+constraints	f	0.5	1	average vehicle requests two routes per peak period	1226	0	2.84E-02	
FMS	EM	cf_hazmat_route_inform ation	=cv_route_number+route	r	0.1	1E-05	once per 1000 vehicles per peak period	0	3754		8.69E-07
FMS	EM	cf_hazmat_vehicle_infor mation	=28	r	0.1	1E-05	once per 1000 vehicles per peak period	0	242		5.60E-08
FMS	ImFrgh tD	To_Intermodal_Freight_ Depot	=64	r	0.5	0.005	one in ten vehicles interacts once with an intermodal carrier	0	530		6.13E-05
FMS	ImFrgh tS	To_Intermodal_Freight_ Shipper	=64	r	0.5	0.005	one in ten vehicles interacts once with an intermodal carrier	0	530		6.13E-05
FMS	ISP	cf_route_request	=trip_request+cv_route_number	r	0.5	0.05	once per vehicle per peak period	0	1234		1.43E-03
FMS	ISP	cv_route_request	=trip_request+vehicle_identity	r	0.5	0.1	twice per vehicle per peak period	0	1354		3.13E-03
FMS	PayInstr	tpi_debited_commercial_ _manager_payment	=4	r	0.5	0.05	once per enrollment	0	50		5.79E-05
ImFrgh tD	FMS	From_Intermodal_Freig ht_Depot	=64	f	0.5	0.005	one in ten vehicles interacts once with an intermodal carrier	530	0	6.13E-05	
ImFrgh tS	FMS	From_Intermodal_Freig ht_Shipper	=64	f	0.5	0.005	one in ten vehicles interacts once with an intermodal carrier	530	0	6.13E-05	
ISP	FMS	cf_route	=cv_route_data+cv_route_number	f	0.5	0.05	once per vehicle per peak period	3034	0	3.51E-03	
ISP	FMS	cv_route	=cv_route_data+vehicle_identity	f	0.5	0.1	twice per vehicle per peak period	3154	0	7.30E-03	

## CVO-Long Haul, 2002, Thruville

LocData	VS	From_Location_Data_Source	=16	f	0.07	0.007	one in ten vehicles uses once per peak period	146	0	2.37E-05	
PayInstr	FMS	fpi_commercial_manager_input_credit_identity	=12	f	0.5	0.05	once per enrollment = once per cv per peak period	114	0	1.32E-04	
VS	EM	emergency_request_driver_details	=date+driver_personal_emergency_request+time	r	0.1	1E-04	one emergency per 1000 vehicles per peak period	0	282		6.53E-07
VS	EM	emergency_request_vehicle_details	=date+time+vehicle_emergency_request	r	0.1	1E-04	one emergency per 1000 vehicles per peak period	0	3354		7.76E-06
VS	ISP	advisory_data_request	=advisory_data_scope+vehicle_location_for_advisories+transit_route_number+transit_vehicle_identity	r	0.1	0.2	two requests per vehicle per peak period	0	290		1.34E-03
VS	ISP	vehicle_guidance_route_accepted	=route_identity	r	0.07	0.14	two acceptances per peak period	0	34		1.10E-04
<b>TOTALS (b/s/user):</b>										<b>1.78E-01</b>	<b>9.91E-02</b>

## Transit, 2002, Thruville

PA Source	PA Sink	Data Flow	Contents	Direc.	Penetration	freq	Freq. Explain	Fwd bits	Rev bits	Fwd rate (b/s/u)	Rev rate (b/s/u)
PayInstr	TRVS	fpi_confirm_fare_payment_on_transit_vehicle	=confirmation_flag	f	1	32	average of one use per transit user per peak period = 32 per transit vehicle	26	0	1.78E-02	
PayInstr	TRVS	fpi_transit_vehicle_tag_data	=credit_identity	f	1	0.032	one data set for 1000 users = 0.032 uses per transit vehicle per peak period	178	0	1.22E-04	
RTS	ISP	traffic_data_kiosk_request	=kiosk_identity+traffic_data_request	r	0.1	0.32	average of one use per transit user per peak period = 32 per transit vehicle	0	98		6.70E-04
RTS	ISP	transit_deviation_kiosk_request	=kiosk_identity+transit_vehicle_deviation_request	r	0.1	0.064	one in five transit users = 6.4 per transit vehicle per peak period	0	66		9.03E-05

## Transit, 2002, Thruville

RTS	ISP	traveler_current_conditi on_request	=kiosk_identity	r	0.1	0.32	average of one use per transit user per peak period = 32 per transit vehicle	0	58		3.97E-04
TRMS	TRVS	approved_corrective_pl an	=transit_route_corrections+transit_changes_in_stops+transit_changes_in_speed	f	1	0.1	one corrective message per ten vehicles per peak period	8210	0	1.75E-02	
TRMS	TRVS	confirm_vehicle_fare_p ayment	=confirmation_flag	f	1	32	average of one use per transit user per peak period = 32 per transit vehicle	26	0	1.78E-02	
TRMS	TRVS	paratransit_transit_drive r_instructions	=128	f	1	13	dispatch message every 15 min. during peak period=48/4(ratio of paratr/tr veh)	1042	0	2.89E-01	
TRMS	TRVS	request_transit_user_im age	=8	f	1	0.032	one image for 1000 users = 0.032 uses per transit vehicle per peak period	82	0	5.61E-05	
TRMS	TRVS	transit_services_for_cor rections	=list_size+1*(2/NUM_TRANSIT_ROUTES)*(transit_ services)	f	1	13	one correction per hour during the peak period	17260	0	4.79E+00	
TRMS	TRVS	transit_services_for_eta	=transit_route_number+transit_route_segment_list+ transit_route_stop_list	f	1	52	update every 15 minutes during the peak period	7786	0	8.65E+00	
TRMS	TRVS	transit_services_for_veh icle_fares	=transit_route_fare_data	f	1	1	update daily during peak period	16826	0	3.60E-01	
TRMS	TRVS	transit_vehicle_advance d_payment_response	=advanced_charges_confirm+advanced_tolls_confir m+confirmation_flag+transit_vehicle_identity	f	1	0.032	one data set for 1000 users = 0.032 uses per transit vehicle per peak period	554	0	3.79E-04	
TRMS	TRVS	transit_vehicle_fare_dat a	=transit_fares	f	1	1	updated once per peak period per transit vehicle	922	0	1.97E-02	
TRMS	TRVS	transit_vehicle_fare_pay ment_debited	=confirmation_flag	f	1	32	average of one use per transit user per peak period = 32 per transit vehicle	26	0	1.78E-02	
TRMS	TRVS	transit_vehicle_fare_pay ment_request	=transit_fare	f	1	32	average of one use per transit user per peak period = 32 per transit vehicle	34	0	2.32E-02	



# Transit, 2002, Thruville

TRVS	PayInstr	tpi_debited_payment_on_transit_vehicle	=4	f	1	32	average of one use per transit user per peak period = 32 per transit vehicle	50	0	3.42E-02	
TRVS	PayInstr	tpi_request_fare_payment_on_transit_vehicle	=2	f	1	32	average of one use per transit user per peak period = 32 per transit vehicle	34	0	2.32E-02	
TRVS	TRMS	paratransit_transit_vehicle_availability	=1	r	1	13	avail. message every 15 min. during peak period=48/4(ratio of paratr/tr veh)	0	26		7.22E-03
TRVS	TRMS	request_vehicle_fare_payment	=credit_identity+transit_fare+transit_route_number+transit_route_segment_number+transit_route_use_time+transit_user_category+traveler_identity	r	1	32	average of one use per peak period per transit user = 32 per transit vehicle	0	466		3.19E-01
TRVS	TRMS	transit_conditions_request	=2	r	1	0.1	one corrective message per ten vehicles per peak period	0	34		7.26E-05
TRVS	TRMS	transit_services_for_eta_request	=transit_vehicle_identity+transit_route_number+transit_route_schedule_number	r	1	3.2	average of one use per 10 transit users per peak period=3.2 per transit vehicle	0	186		1.27E-02
TRVS	TRMS	transit_user_vehicle_image	=JPEG*(ftu_transit_user_vehicle_image)	r	1	0.011	20 images per metro area per peak period=20/1788 transit vehicles	0	73746		1.73E-02
TRVS	TRMS	transit_vehicle_arrival_conditions	=128	r	1	13	updated every 60 minutes during the peak period	0	1042		2.89E-01
TRVS	TRMS	transit_vehicle_collected_trip_data	=transit_vehicle_passenger_loading+transit_vehicle_running_times	r	1	13	every hour for each transit vehicle per peak period	0	1826		5.07E-01
TRVS	TRMS	transit_vehicle_deviations_from_schedule	=32	r	1	52	update every 15 minutes during the peak period	0	274		3.04E-01
TRVS	TRMS	transit_vehicle_eta	=transit_vehicle_identity+transit_vehicle_time+transit_route_number	r	1	156	updated every 5 minutes during the peak period	0	234		7.80E-01
TRVS	TRMS	transit_vehicle_fare_payment_confirmation	=confirmation_flag	r	1	32	average of one use per transit user per peak period = 32 per transit vehicle	0	26		1.78E-02

<b>Transit, 2002, Thruville</b>											
TRVS	TRMS	transit_vehicle_location	=transit_vehicle_identity+transit_vehicle_location_data	r	1	52	updated every 15 minutes during the peak period	0	250		2.78E-01
TRVS	TRMS	transit_vehicle_location_for_deviation	=transit_vehicle_identity+transit_vehicle_location_data	r	1	52	updated every 15 minutes during the peak period	0	250		2.78E-01
TRVS	TRMS	transit_vehicle_location_for_store	=transit_vehicle_identity+transit_vehicle_location_data	r	1	13	updated every 60 minutes during the peak period	0	250		6.94E-02
TRVS	TRMS	transit_vehicle_passenger_data	=transit_passenger_numbers+transit_route_number+transit_route_segment_number+transit_route_use_time+transit_user_category+transit_vehicle_identity	r	1	52	update every 15 minutes during the peak period	0	242		2.69E-01
TRVS	TRMS	transit_vehicle_schedule_deviation	=32	r	1	52	updated every 15 minutes during the peak period	0	274		3.04E-01
<b>TOTALS (b/s/user):</b>									<b>1.43E+01</b>	<b>3.45E+00</b>	

<b>Emergency Management, 2002, Thruville</b>											
PA Source	PA Sink	Data Flow	Contents	Dir c.	Pene tration	freq	Freq. Explain	Fwd bits	Rev bits	Fwd rate (b/s/u)	Rev rate (b/s/u)
EM	EVS	emergency_vehicle_driver_outputs	=128	f	1	13	average one driver output per vehicle per hour during the peak period	1042	0	2.89E-01	
EVS	EM	emergency_driver_dispatch_acknowledge	=1	r	1	26	average one dispatch acknowledge per vehicle per 1/2 hour during the peak period	0	26		1.44E-02
EVS	EM	emergency_driver_status_update	=16	r	1	26	average one status update per vehicle per 1/2 hour during the peak period	0	146		8.11E-02
EVS	EM	emergency_vehicle_driver_inputs	=64	r	1	13	average one driver input per vehicle per hour during the peak period	0	530		1.47E-01
<b>TOTALS (b/s/user):</b>									<b>2.89E-01</b>	<b>2.43E-01</b>	

<b>Probes, 2002, Thruville</b>												
PA Source	PA Sink	Data Flow	Contents	Dir ec.	Penetration	freq	Freq. Explain	Fwd bits	Rev bits	Fwd rate (b/s/u)	Rev rate (b/s/u)	
VS	ISP	vehicle_guidance_probe_data	=route_segment_identity+vehicle_identity	r	1	12	average of 12 probe reports per vehicle per peak period	0	314		1.74E-01	
<b>TOTALS (b/s/user):</b>										<b>0.00E+00</b>	<b>1.74E-01</b>	

<b>Private Vehicle, 2002, Mountainville</b>												
PA Source	PA Sink	Data Flow	Contents	Dir ec.	Penetration	freq	Freq. Explain	Fwd bits	Rev bits	Fwd rate (b/s/u)	Rev rate (b/s/u)	
EM	VS	emergency_request_driver_acknowledge	=1	f	0.1	1E-04	one emergency per 1000 vehicles per peak period	26	0	1.20E-07		
EM	VS	emergency_request_vehicle_acknowledge	=1	f	0.1	1E-04	one emergency per 1000 vehicles per peak period	26	0	1.20E-07		
PayInstr	VS	fpi_transit_user_vehicle_input_credit_identity	=credit_identity	f	1	1E-04	one in 10000 vehicles uses this flow per peak period	178	0	8.24E-07		
VS	EM	emergency_request_driver_details	=date+driver_personal_emergency_request+time	r	0.1	1E-04	one emergency per 1000 vehicles per peak period	0	282		1.31E-06	
VS	EM	emergency_request_vehicle_details	=date+time+vehicle_emergency_request	r	0.1	1E-04	one emergency per 1000 vehicles per peak period	0	3354		1.55E-05	
<b>TOTALS (b/s/user):</b>										<b>1.06E-06</b>	<b>1.68E-05</b>	

## Traveler, 2002, Mountainville

PA Source	PA Sink	Data Flow	Contents	Dir c.	Penetration	freq	Freq. Explain	Fwd bits	Rev bits	Fwd rate (b/s/u)	Rev rate (b/s/u)
EM	PIAS	emergency_request_personal_traveler_acknowledge	=confirmation_flag	f	0.1	3E-05	one emergency per 2000 users in peak period	26	0	3.01E-08	
PIAS	EM	emergency_request_personal_traveler_details	=date+time+traveler_personal_emergency_request	r	0.1	3E-05	one emergency per 2000 users in peak period	0	370		4.28E-07
<b>TOTALS (b/s/user):</b>										<b>3.01E-08</b>	<b>4.28E-07</b>

## CVO-Local, 2002, Mountainville

PA Source	PA Sink	Data Flow	Contents	Dir c.	Penetration	freq	Freq. Explain	Fwd bits	Rev bits	Fwd rate (b/s/u)	Rev rate (b/s/u)
CVS	FMS	cf_driver_route_instructions_request	=cv_driver_number+cv_route_number	r	0.5	1	average fleet vehicle requests two routes per peak period	0	154		3.56E-03
CVS	FMS	cv_driver_route_request	=trip_request+route_type	r	0.5	2	average vehicle requests 4 routes per peak period	0	1234		5.71E-02
CVS	FMS	cv_driver_storage_request	=cv_route_number	r	0.5	0.05	one in ten vehicles per peak period	0	26		3.01E-05
CVS	FMS	cv_static_route_data	=256	r	0.5	2	four routes per vehicle per peak period	0	2066		9.56E-02
EM	FMS	cf_hazmat_request	=16	f	0.1	1E-05	once per 1000 vehicles per peak period	146	0	3.38E-08	
EM	VS	emergency_request_driver_acknowledge	=1	f	0.1	1E-04	one emergency per 1000 vehicles per peak period	26	0	6.02E-08	
EM	VS	emergency_request_vehicle_acknowledge	=1	f	0.1	1E-04	one emergency per 1000 vehicles per peak period	26	0	6.02E-08	
FMS	CVS	cf_driver_route_instructions	=cf_driver_route+cf_driver_load_details	f	0.5	1	twice per vehicle per peak period	5082	0	1.18E-01	

## CVO-Local, 2002, Mountainville

FMS	CVS	cv_driver_route_data	=cv_route_data+route_type+cv_route_number	f	0.5	2	average vehicle requests four routes per peak period	3042	0	1.41E-01	
FMS	CVS	cv_static_route_request	=origin+destination+departure_time+desired_arrival_time+preferences+constraints	f	0.5	2	average vehicle requests four routes per peak period	1226	0	5.68E-02	
FMS	EM	cf_hazmat_route_information	=cv_route_number+route	r	0.1	1E-05	once per 1000 vehicles per peak period	0	3754		8.69E-07
FMS	EM	cf_hazmat_vehicle_information	=28	r	0.1	1E-05	once per 1000 vehicles per peak period	0	242		5.60E-08
FMS	ImFrghD	To_Intermodal_Freight_Depot	=64	r	0.5	0.005	one in ten of vehicles interact once with an intermodal carrier	0	530		6.13E-05
FMS	ImFrghS	To_Intermodal_Freight_Shipper	=64	r	0.5	0.005	one in ten of vehicles interact once with an intermodal carrier	0	530		6.13E-05
FMS	ISP	cf_route_request	=trip_request+cv_route_number	r	0.5	0.1	twice per vehicle per peak period	0	1234		2.86E-03
FMS	ISP	cv_route_request	=trip_request+vehicle_identity	r	0.5	0.2	four times per vehicle per peak period	0	1354		6.27E-03
ImFrghD	FMS	From_Intermodal_Freight_Depot	=64	f	0.5	0.005	one in ten of vehicles interact once with an intermodal carrier	530	0	6.13E-05	
ImFrghS	FMS	From_Intermodal_Freight_Shipper	=64	f	0.5	0.005	one in ten of vehicles interact once with an intermodal carrier	530	0	6.13E-05	
ISP	FMS	cf_route	=cv_route_data+cv_route_number	f	0.5	0.1	twice per vehicle per peak period	3034	0	7.02E-03	
ISP	FMS	cv_route	=cv_route_data+vehicle_identity	f	0.5	0.2	four times per vehicle per peak period	3154	0	1.46E-02	
VS	EM	emergency_request_driver_details	=date+driver_personal_emergency_request+time	r	0.1	1E-04	one emergency per 1000 vehicles per peak period	0	282		6.53E-07
VS	EM	emergency_request_vehicle_details	=date+time+vehicle_emergency_request	r	0.1	1E-04	one emergency per 1000 vehicles per peak period	0	3354		7.76E-06
<b>TOTALS (b/s/user):</b>										<b>3.37E-01</b>	<b>1.66E-01</b>

## CVO-Long Haul, 2002, Mountainville

PA Source	PA Sink	Data Flow	Contents	Dir	Penetration	freq	Freq. Explain	Fwd bits	Rev bits	Fwd rate (b/s/u)	Rev rate (b/s/u)
CVAS	CVCS	cv_credentials_database_update	=cv_credentials_details+cv_credentials_status_code+cv_trip_classification_data	f	0.5	5E-05	one out of 1000 vehicles per peak period	482	0	5.58E-07	
CVAS	CVCS	cv_credentials_information_response	=cv_credentials_details+cv_credentials_status_code	f	0.5	0.005	one out of 10 vehicles	410	0	4.75E-05	
CVAS	CVCS	cv_safety_database_update	=cv_credentials_details+cv_roadside_safety_data	f	1	0.001	one out of 100 vehicles	410	0	9.49E-06	
CVAS	CVCS	cv_safety_information_response	=cv_credentials_details+cv_roadside_safety_data	f	1	0.001	one out of 100 vehicles are transmitted	410	0	9.49E-06	
CVAS	FMS	cf_clearance_enrollment_confirm	=confirmation_flag	f	0.5	0.05	once per vehicle per peak period	26	0	3.01E-05	
CVAS	FMS	cf_enrollment_information	=cv_route_number+cv_taxes_and_duties+route+route_type	f	0.5	0.025	one out of two vehicles require info. per peak period	3818	0	2.21E-03	
CVAS	FMS	cf_enrollment_payment_confirmation	=cv_route_number+cv_account_number+cv_amount_billed	f	0.5	0.05	once per vehicle per peak period	170	0	1.97E-04	
CVAS	FMS	cv_enrollment_information	=cv_route_number+cv_taxes_and_duties+route+route_type	f	0.5	0.025	one out of two vehicles require info. per peak period	3818	0	2.21E-03	
CVAS	FMS	cv_enrollment_payment_confirmation	=cv_account_number+cv_amount_billed+cv_driver_credit_identity+cv_route_number	f	0.5	0.05	once per vehicle per peak period	346	0	4.00E-04	
CVCS	CVAS	cv_credentials_information_request	=cv_credentials_details+cv_credentials_request_type+cv_credentials_request_identity+cv_roadside_facility_identity	r	0.5	0.005	request info on one in ten vehicles	0	554		6.41E-05
CVCS	CVAS	cv_roadside_daily_log	=cv_roadside_facility_identity+date++cv_archived_safety_data+cv_archived_inspection_data+cv_screening_record	r	0.5	5E-04	one report per 100 vehicles per peak period	0	3362		3.89E-05
CVCS	CVAS	cv_safety_information_request	=cv_credentials_details+cv_safety_information_request_identity+cv_safety_information_request_type+cv_roadside_facility_identity	r	1	0.01	request info on one in ten vehicles	0	554		1.28E-04
CVCS	CVAS	cv_update_safety_problems_list	=cv_credentials_details+cv_roadside_facility_identity+cv_roadside_safety_data	r	1	0.001	one out of 100 vehicles are on the list per peak period	0	538		1.25E-05

## CVO-Long Haul, 2002, Mountainville

CVS	FMS	cf_driver_route_instructions_request	=cv_driver_number+cv_route_number	r	0.5	0.5	average fleet vehicle requests one route per peak period	0	154		1.78E-03
CVS	FMS	cv_driver_enrollment_payment_request	=cv_account_number+cv_driver_credit_identity+cv_route_number	r	0.5	0.5	once per vehicle per peak period	0	330		3.82E-03
CVS	FMS	cv_driver_enrollment_request	=cv_cargo_class+cv_route_number+cv_vehicle_class+cv_weight_class	r	0.5	0.5	once per vehicle per peak period	0	98		1.13E-03
CVS	FMS	cv_driver_route_request	=trip_request+route_type	r	0.5	1	average vehicle requests 2 routes per peak period	0	1234		2.86E-02
CVS	FMS	cv_driver_storage_request	=cv_route_number	r	0.5	0.05	one in ten vehicles per peak period	0	26		3.01E-05
CVS	FMS	cv_static_route_data	=256	r	0.5	1	two routes per vehicle per peak period	0	2066		4.78E-02
EM	FMS	cf_hazmat_request	=16	f	0.1	1E-05	once per 1000 vehicles per peak period	146	0	3.38E-08	
EM	VS	emergency_request_driver_acknowledge	=1	f	0.1	1E-04	one emergency per 1000 vehicles per peak period	26	0	6.02E-08	
EM	VS	emergency_request_vehicle_acknowledge	=1	f	0.1	1E-04	one emergency per 1000 vehicles per peak period	26	0	6.02E-08	
FMS	CVAS	cf_enroll_clearance_data	=cv_credentials_details	r	0.5	0.05	once per vehicle per peak period	0	402		4.65E-04
FMS	CVAS	cf_enrollment_payment_request	=cf_manager_credit_identity+cv_account_number+cv_route_number+1.5*(cv_taxes_and_duties)	r	0.5	0.05	once per vehicle per peak period	0	414		4.79E-04
FMS	CVAS	cf_enrollment_request	=cv_route_data+cv_credentials_details+cv_route_number+cv_trip_classification_data+route_type	r	0.5	0.05	once per vehicle per peak period	0	3498		4.05E-03
FMS	CVAS	cv_enrollment_payment_request	=cv_account_number+cv_driver_credit_identity+cv_route_number+1.5*(cv_taxes_and_duties)	r	0.5	0.05	once per vehicle per peak period	0	414		4.79E-04
FMS	CVAS	cv_enrollment_request	=cv_route_data+cv_credentials_details+cv_trip_classification_data+cv_route_number+route_type	r	0.5	0.05	once per vehicle per peak period	0	3498		4.05E-03
FMS	CVS	cf_driver_route_instructions	=cf_driver_route+cf_driver_load_details	f	0.5	0.5	once per vehicle per peak period	5082	0	5.88E-02	

## CVO-Long Haul, 2002, Mountainville

FMS	CVS	cv_driver_enrollment_in formation	=cv_route_number+cv_taxes_and_duties	f	0.5	0.25	one out of two vehicles require info. per peak period	82	0	4.75E-04	
FMS	CVS	cv_driver_enrollment_p ayment_confirmation	=cv_account_number+cv_amount_billed+cv_driver _credit_identity+cv_route_number	f	0.5	0.5	once per vehicle per peak period	346	0	4.00E-03	
FMS	CVS	cv_driver_route_data	=cv_route_data+route_type+cv_route_number	f	0.5	1	average vehicle requests two routes per peak period	3042	0	7.04E-02	
FMS	CVS	cv_static_route_request	=origin+destination+departure_time+desired_arrival _time+preferences+constraints	f	0.5	1	average vehicle requests two routes per peak period	1226	0	2.84E-02	
FMS	EM	cf_hazmat_route_inform ation	=cv_route_number+route	r	0.1	1E-05	once per 1000 vehicles per peak period	0	3754		8.69E-07
FMS	EM	cf_hazmat_vehicle_infor mation	=28	r	0.1	1E-05	once per 1000 vehicles per peak period	0	242		5.60E-08
FMS	ImFrgh tD	To_Intermodal_Freight_ Depot	=64	r	0.5	0.005	one in ten vehicles interacts once with an intermodal carrier	0	530		6.13E-05
FMS	ImFrgh tS	To_Intermodal_Freight_ Shipper	=64	r	0.5	0.005	one in ten vehicles interacts once with an intermodal carrier	0	530		6.13E-05
FMS	ISP	cf_route_request	=trip_request+cv_route_number	r	0.5	0.05	once per vehicle per peak period	0	1234		1.43E-03
FMS	ISP	cv_route_request	=trip_request+vehicle_identity	r	0.5	0.1	twice per vehicle per peak period	0	1354		3.13E-03
FMS	PayInstr	tpi_debited_commercial_ _manager_payment	=4	r	0.5	0.05	once per enrollment	0	50		5.79E-05
ImFrgh tD	FMS	From_Intermodal_Freig ht_Depot	=64	f	0.5	0.005	one in ten vehicles interacts once with an intermodal carrier	530	0	6.13E-05	
ImFrgh tS	FMS	From_Intermodal_Freig ht_Shipper	=64	f	0.5	0.005	one in ten vehicles interacts once with an intermodal carrier	530	0	6.13E-05	
ISP	FMS	cf_route	=cv_route_data+cv_route_number	f	0.5	0.05	once per vehicle per peak period	3034	0	3.51E-03	
ISP	FMS	cv_route	=cv_route_data+vehicle_identity	f	0.5	0.1	twice per vehicle per peak period	3154	0	7.30E-03	



<b>CVO-Long Haul, 2002, Mountainville</b>											
PayInstr	FMS	fpi_commercial_manager_input_credit_identity	=12	f	0.5	0.05	once per enrollment = once per cv per peak period	114	0	1.32E-04	
VS	EM	emergency_request_driver_details	=date+driver_personal_emergency_request+time	r	0.1	1E-04	one emergency per 1000 vehicles per peak period	0	282		6.53E-07
VS	EM	emergency_request_vehicle_details	=date+time+vehicle_emergency_request	r	0.1	1E-04	one emergency per 1000 vehicles per peak period	0	3354		7.76E-06
<b>TOTALS (b/s/user):</b>										<b>1.78E-01</b>	<b>9.77E-02</b>

<b>Transit, 2002, Mountainville</b>											
PA Source	PA Sink	Data Flow	Contents	Dir c.	Pene tration	freq	Freq. Explain	Fwd bits	Rev bits	Fwd rate (b/s/u)	Rev rate (b/s/u)
PayInstr	TRVS	fpi_confirm_fare_payment_on_transit_vehicle	=confirmation_flag	f	1	32	average of one use per transit user per peak period = 32 per transit vehicle	26	0	1.78E-02	
PayInstr	TRVS	fpi_transit_vehicle_tag_data	=credit_identity	f	1	0.032	one data set for 1000 users = 0.032 uses per transit vehicle per peak period	178	0	1.22E-04	
TRMS	TRVS	confirm_vehicle_fare_payment	=confirmation_flag	f	1	32	average of one use per transit user per peak period = 32 per transit vehicle	26	0	1.78E-02	
TRMS	TRVS	request_transit_user_image	=8	f	1	0.032	one image for 1000 users = 0.032 uses per transit vehicle per peak period	82	0	5.61E-05	
TRMS	TRVS	transit_services_for_vehicle_fares	=transit_route_fare_data	f	1	1	update daily during peak period	16826	0	3.60E-01	
TRMS	TRVS	transit_vehicle_advanced_payment_response	=advanced_charges_confirm+advanced_tolls_confirm+confirmation_flag+transit_vehicle_identity	f	1	0.032	one data set for 1000 users = 0.032 uses per transit vehicle per peak period	554	0	3.79E-04	

## Transit, 2002, Mountainville

TRMS	TRVS	transit_vehicle_fare_data	=transit_fares	f	1	1	updated once per peak period per transit vehicle	922	0	1.97E-02	
TRMS	TRVS	transit_vehicle_fare_payment_debited	=confirmation_flag	f	1	32	average of one use per transit user per peak period = 32 per transit vehicle	26	0	1.78E-02	
TRMS	TRVS	transit_vehicle_fare_payment_request	=transit_fare	f	1	32	average of one use per transit user per peak period = 32 per transit vehicle	34	0	2.32E-02	
TRVS	PayInstr	tpi_debited_payment_on_transit_vehicle	=4	f	1	32	average of one use per transit user per peak period = 32 per transit vehicle	50	0	3.42E-02	
TRVS	PayInstr	tpi_request_fare_payment_on_transit_vehicle	=2	f	1	32	average of one use per transit user per peak period = 32 per transit vehicle	34	0	2.32E-02	
TRVS	TRMS	request_vehicle_fare_payment	=credit_identity+transit_fare+transit_route_number+transit_route_segment_number+transit_route_use_time+transit_user_category+traveler_identity	r	1	32	average of one use per peak period per transit user = 32 per transit vehicle	0	466		3.19E-01
TRVS	TRMS	transit_user_vehicle_image	=JPEG*(ftu_transit_user_vehicle_image)	r	1	0.011	20 images per metro area per peak period=20/1788 transit vehicles	0	73746		1.73E-02
TRVS	TRMS	transit_vehicle_fare_payment_confirmation	=confirmation_flag	r	1	32	average of one use per transit user per peak period = 32 per transit vehicle	0	26		1.78E-02
TRVS	TRMS	transit_vehicle_passenger_data	=transit_passenger_numbers+transit_route_number+transit_route_segment_number+transit_route_use_time+transit_user_category+transit_vehicle_identity	r	1	52	update every 15 minutes during the peak period	0	242		2.69E-01
<b>TOTALS (b/s/user):</b>										<b>5.14E-01</b>	<b>6.23E-01</b>

## Emergency Management, 2002, Mountainville

PA Source	PA Sink	Data Flow	Contents	Direc.	Penetration	freq	Freq. Explain	Fwd bits	Rev bits	Fwd rate (b/s/u)	Rev rate (b/s/u)
EM	EVS	emergency_vehicle_driver_outputs	=128	f	1	13	average one driver output per vehicle per hour during the peak period	1042	0	2.89E-01	
EVS	EM	emergency_driver_dispatch_acknowledge	=1	r	1	26	average one dispatch acknowledge per vehicle per 1/2 hour during the peak period	0	26		1.44E-02
EVS	EM	emergency_driver_statuses_update	=16	r	1	26	average one status update per vehicle per 1/2 hour during the peak period	0	146		8.11E-02
EVS	EM	emergency_vehicle_driver_inputs	=64	r	1	13	average one driver input per vehicle per hour during the peak period	0	530		1.47E-01
<b>TOTALS (b/s/user):</b>										<b>2.89E-01</b>	<b>2.43E-01</b>

## Private Vehicle, 2012, Urbansville

PA Source	PA Sink	Data Flow	Contents	Dir	Penetration	freq	Freq. Explain	Fwd bits	Rev bits	Fwd rate (b/s/u)	Rev rate (b/s/u)
EM	VS	emergency_request_driver_acknowledge	=1	f	0.3	3E-04	one emergency per 1000 vehicles per peak period	26	0	3.61E-07	
EM	VS	emergency_request_vehicle_acknowledge	=1	f	0.3	3E-04	one emergency per 1000 vehicles per peak period	26	0	3.61E-07	
ISP	VS	advanced_fares_and_charges_response	=confirmation_flag+credit_identity+parking_lot_cost+stored_credit+transit_fare	f	0.2	2E-04	one user per 1000 users per peak period	234	0	2.17E-06	
ISP	VS	advanced_tolls_and_fares_response	=confirmation_flag+credit_identity+stored_credit+toll_cost+transit_fare	f	0.2	2E-04	one user per 1000 users per peak period	234	0	2.17E-06	
ISP	VS	advisory_data	=traffic_data_for_advisories+predicted_incidents_for_advisories+prediction_data_for_advisories+transit_services_for_advisories+transit_running_data_for_advisories	f	0.2	0.2	one set of data per peak period	6146	0	5.69E-02	
ISP	VS	yellow_pages_advisory_data	=yellow_pages_data_for_advisories+yellow_pages_cost+yellow_pages_dining_reservation_confirmation+yellow_pages_lodging_reservation_confirmation+yellow_pages_ticket_purchase_confirmation	f	0.2	0.02	one yellow pages advisory per 10 vehicles per peak period	10802	0	1.00E-02	
LocData	VS	From_Location_Data_Source	=16	f	0.3	0.03	one in ten vs uses per peak period	146	0	2.03E-04	
PayInstr	VS	fpi_driver_vehicle_input_credit_identity	=credit_identity	f	0.2	2E-04	one vehicle per 1000 per peak period	178	0	1.65E-06	
PayInstr	VS	fpi_transit_user_vehicle_input_credit_identity	=credit_identity	f	1	1E-04	one in 10000 vehicles uses this flow per peak period	178	0	8.24E-07	
VS	EM	emergency_request_driver_details	=date+driver_personal_emergency_request+time	r	0.3	3E-04	one emergency per 1000 vehicles per peak period	0	282		3.92E-06
VS	EM	emergency_request_vehicle_details	=date+time+vehicle_emergency_request	r	0.3	3E-04	one emergency per 1000 vehicles per peak period	0	3354		4.66E-05
VS	ISP	advanced_fares_and_charges_request	=0.6*(advanced_fare_details)+0.6*(advanced_parking_lot_charges)	r	0.2	2E-04	one user per 1000 users per peak period	0	632.4		5.86E-06
VS	ISP	advanced_tolls_and_fares_request	=0.6*(advanced_fare_details)+0.6*(advanced_tolls)	r	0.2	2E-04	one user per 1000 users per peak period	0	642		5.94E-06

## Private Vehicle, 2012, Urbansville

VS	ISP	advisory_data_request	=advisory_data_scope+vehicle_location_for_advisories+transit_route_number+transit_vehicle_identity	r	0.2	0.2	one request per vehicle per peak period	0	290		2.69E-03
VS	ISP	vehicle_guidance_route_accepted	=route_identity	r	0.3	0.6	two acceptances per peak period	0	34		9.44E-04
VS	ISP	yellow_pages_advisory_requests	=advisory_data_scope+vehicle_location_for_advisories+transit_route_number+transit_vehicle_identity+yellow_pages_dining_reservation+yellow_pages_lodging_reservation+yellow_pages_ticket_purchase	r	0.2	0.02	one yellow pages advisory per ten vehicles per peak period	0	674		6.24E-04
VS	PayInstr	tpi_debited_driver_payment_at_vehicle	=4	r	0.2	2E-04	one vehicle per 1000 per peak period	0	50		4.63E-07
VS	PMS	advanced_parking_lot_charges_request	=credit_identity+parking_lot_identity+parking_space_details+stored_credit+vehicle_identity	r	0.2	1E-04	one user per 1000 users per peak period	0	514		2.38E-06
VS	PMS	parking_lot_payment_confirmation	=confirmation_flag	r	0.2	1E-04	one vehicle per 1000 per peak period	0	26		1.20E-07
<b>TOTALS (b/s/user):</b>									<b>6.71E-02</b>	<b>4.32E-03</b>	

## Traveler, 2012, Urbansville

PA Source	PA Sink	Data Flow	Contents	Dire c.	Pene tration	freq	Freq. Explain	Fwd bits	Rev bits	Fwd rate (b/s/u)	Rev rate (b/s/u)
EM	PIAS	emergency_request_personal_traveler_acknowledge	=confirmation_flag	f	0.3	8E-05	one emergency per 2000 users in peak period	26	0	9.03E-08	
ISP	PIAS	transit_deviations_for_portables	=traveler_identity+list_size+TRANSIT_SEGS*(transit_vehicle_identity+transit_vehicle_achieved_time+transit_route_segment_number)	f	0.2	5E-04	one request per 20 pias per peak period	3578	0	8.28E-05	
ISP	PIAS	traveler_guidance_route	=route_identity+traveler_route+traveler_identity	f	0.3	0.015	one route per day per pias	18306	0	1.27E-02	
ISP	PIAS	traveler_personal_payment_confirmation	=advanced_tolls_confirm+advanced_fares_confirm+advanced_parking_lot_charges_confirm+credit_identity+stored_credit+traveler_identity+traveler_total_trip_cost	f	0.2	0.01	one payment per 10 pias per peak period	818	0	3.79E-04	
ISP	PIAS	traveler_personal_transaction_confirmation	=credit_identity+traveler_identity+transaction_number+yellow_pages_cost+yellow_pages_lodging_reservation_confirmation+yellow_pages_dining_reservation_confirmation+yellow_pages_ticket_purchase_confirmation	f	0.2	0.01	one confirmation per 10 pias per day	650	0	3.01E-04	
ISP	PIAS	traveler_personal_yellow_pages_data	=traveler_identity+0.01*(yellow_pages_general_information+yellow_pages_specific_information+yellow_pages_transaction_information)	f	0.2	0.1	one yellow pages response per pias per peak period	1140	0	5.28E-03	
LocData	PIAS	From_Location_Data_Source	=16	f	0.3	0.03	one in ten pias uses per peak period	146	0	2.03E-04	
PayInstr	PIAS	fpi_traveler_personal_input_credit_identity	=credit_identity	f	0.2	0.01	one transaction per 10 pias per day	178	0	8.24E-05	
PIAS	EM	emergency_request_personal_traveler_details	=date+time+traveler_personal_emergency_request	r	0.3	8E-05	one emergency per 2000 users in peak period	0	370		1.28E-06
PIAS	ISP	traffic_data_portables_request	=traffic_data_request+traveler_identity	r	0.2	0.1	one request per pias per peak period	0	250		1.16E-03
PIAS	ISP	transit_deviations_portables_request	=traveler_identity+transit_vehicle_deviation_request+transit_route_number	r	0.2	0.005	one request per 20 pias per peak period	0	250		5.79E-05

<b>Traveler, 2012, Urbansville</b>											
PIAS	ISP	traveler_personal_current_condition_request	=traveler_identity	r	0.2	0.1	one request per pias per peak period	0	210		9.72E-04
PIAS	ISP	traveler_personal_payment_information	=credit_identity+parking_space_details+ride_segments+stored_credit+toll_segments+traveler_identity	r	0.2	0.01	one payment per 10 pias per peak period	0	1130		5.23E-04
PIAS	ISP	traveler_personal_transaction_request	=yellow_pages_dining_reservation+yellow_pages_lodging_reservation+yellow_pages_ticket_purchase	r	0.2	0.01	one request per 10 pias per peak period	0	402		1.86E-04
PIAS	ISP	traveler_personal_yellow_pages_information_request	=1	r	0.2	0.1	one yellow pages request per pias per peak period	0	26		1.20E-04
PIAS	PayInstr	tpi_debited_payment_at_personal_device	=4	r	0.2	0.01	one transaction per 10 pias per day	0	50		2.31E-05
PIAS	TRMS	transit_services_portables_request	=destination+origin+traveler_identity	r	0.2	0.01	one request per 10 pias per peak period	0	466		2.16E-04
TRMS	PIAS	transit_services_for_portables	=traveler_identity+2*(transit_services_for_output)	f	0.2	0.003	one request per 20 pias per peak period	2530	0	3.87E-04	
<b>TOTALS (b/s/user):</b>									<b>1.94E-02</b>	<b>3.26E-03</b>	

## CVO-Local, 2012, Urbansville

PA Source	PA Sink	Data Flow	Contents	Dir c.	Penetration	freq	Freq. Explain	Fwd bits	Rev bits	Fwd rate (b/s/u)	Rev rate (b/s/u)
CVS	FMS	cf_driver_route_instructions_request	=cv_driver_number+cv_route_number	r	0.8	1.6	average fleet vehicle requests two routes per peak period	0	154		5.70E-03
CVS	FMS	cv_driver_route_request	=trip_request+route_type	r	0.8	3.2	average vehicle requests 4 routes per peak period	0	1234		9.14E-02
CVS	FMS	cv_driver_storage_request	=cv_route_number	r	0.8	0.08	one in ten vehicles per peak period	0	26		4.81E-05
CVS	FMS	cv_static_route_data	=256	r	0.8	3.2	four routes per vehicle per peak period	0	2066		1.53E-01
EM	FMS	cf_hazmat_request	=16	f	0.5	5E-05	once per 1000 vehicles per peak period	146	0	1.69E-07	
EM	VS	emergency_request_driver_acknowledge	=1	f	0.3	3E-04	one emergency per 1000 vehicles per peak period	26	0	1.81E-07	
EM	VS	emergency_request_vehicle_acknowledge	=1	f	0.3	3E-04	one emergency per 1000 vehicles per peak period	26	0	1.81E-07	
FMS	CVS	cf_driver_route_instructions	=cf_driver_route+cf_driver_load_details	f	0.8	1.6	twice per vehicle per peak period	5082	0	1.88E-01	
FMS	CVS	cv_driver_route_data	=cv_route_data+route_type+cv_route_number	f	0.8	3.2	average vehicle requests four routes per peak period	3042	0	2.25E-01	
FMS	CVS	cv_static_route_request	=origin+destination+departure_time+desired_arrival_time+preferences+constraints	f	0.8	3.2	average vehicle requests four routes per peak period	1226	0	9.08E-02	
FMS	EM	cf_hazmat_route_information	=cv_route_number+route	r	0.5	5E-05	once per 1000 vehicles per peak period	0	3754		4.34E-06
FMS	EM	cf_hazmat_vehicle_information	=28	r	0.5	5E-05	once per 1000 vehicles per peak period	0	242		2.80E-07
FMS	ImFrghD	To_Intermodal_Freight_Depot	=64	r	0.8	0.008	one in ten of vehicles interact once with an intermodal carrier	0	530		9.81E-05
FMS	ImFrghS	To_Intermodal_Freight_Shipper	=64	r	0.8	0.008	one in ten of vehicles interact once with an intermodal carrier	0	530		9.81E-05



## CVO-Local, 2012, Urbansville

FMS	ISP	cf_route_request	=trip_request+cv_route_number	r	0.8	0.16	twice per vehicle per peak period	0	1234		4.57E-03
FMS	ISP	cv_route_request	=trip_request+vehicle_identity	r	0.8	0.32	four times per vehicle per peak period	0	1354		1.00E-02
ImFrghD	FMS	From_Intermodal_Freight_Depot	=64	f	0.8	0.008	one in ten of vehicles interact once with an intermodal carrier	530	0		9.81E-05
ImFrghS	FMS	From_Intermodal_Freight_Shipper	=64	f	0.8	0.008	one in ten of vehicles interact once with an intermodal carrier	530	0		9.81E-05
ISP	FMS	cf_route	=cv_route_data+cv_route_number	f	0.8	0.16	twice per vehicle per peak period	3034	0		1.12E-02
ISP	FMS	cv_route	=cv_route_data+vehicle_identity	f	0.8	0.32	four times per vehicle per peak period	3154	0		2.34E-02
ISP	VS	advanced_fares_and_charges_response	=confirmation_flag+credit_identity+parking_lot_cost+stored_credit+transit_fare	f	0.2	2E-04	one user per 1000 users per peak period	234	0		1.08E-06
ISP	VS	advanced_tolls_and_fares_response	=confirmation_flag+credit_identity+stored_credit+toll_cost+transit_fare	f	0.2	2E-04	one user per 1000 users per peak period	234	0		1.08E-06
ISP	VS	advisory_data	=traffic_data_for_advisories+predicted_incidents_for_advisories+prediction_data_for_advisories+transit_services_for_advisories+transit_running_data_for_advisories	f	0.2	0.4	two sets of data per peak period	6146	0		5.69E-02
ISP	VS	yellow_pages_advisory_data	=yellow_pages_data_for_advisories+yellow_pages_cost+yellow_pages_dining_reservation_confirmation+yellow_pages_lodging_reservation_confirmation+yellow_pages_ticket_purchase_confirmation	f	0.2	0.02	one yellow pages advisory per 10 vehicles per peak period	10802	0		5.00E-03
LocData	VS	From_Location_Data_Source	=16	f	0.3	0.03	one in ten vehicles uses once per peak period	146	0		1.01E-04
PayInstr	VS	fpi_driver_vehicle_input_credit_identity	=credit_identity	f	0.2	2E-04	one vehicle per 1000 per peak period	178	0		8.24E-07
VS	EM	emergency_request_driver_details	=date+driver_personal_emergency_request+time	r	0.3	3E-04	one emergency per 1000 vehicles per peak period	0	282		1.96E-06
VS	EM	emergency_request_vehicle_details	=date+time+vehicle_emergency_request	r	0.3	3E-04	one emergency per 1000 vehicles per peak period	0	3354		2.33E-05

<b>CVO-Local, 2012, Urbansville</b>											
VS	ISP	advanced_fares_and_charges_request	=0.6*(advanced_fare_details)+0.6*(advanced_parking_lot_charges)	r	0.2	2E-04	one user per 1000 users per peak period	0	632.4		2.93E-06
VS	ISP	advanced_tolls_and_fares_request	=0.6*(advanced_fare_details)+0.6*(advanced_tolls)	r	0.2	2E-04	one user per 1000 users per peak period	0	642		2.97E-06
VS	ISP	advisory_data_request	=advisory_data_scope+vehicle_location_for_advisories+transit_route_number+transit_vehicle_identity	r	0.2	0.4	two requests per vehicle per peak period	0	290		2.69E-03
VS	ISP	yellow_pages_advisory_requests	=advisory_data_scope+vehicle_location_for_advisories+transit_route_number+transit_vehicle_identity+yellow_pages_dining_reservation+yellow_pages_lodging_reservation+yellow_pages_ticket_purchase	r	0.2	0.02	one yellow pages advisory per 10 vehicles per peak period	0	674		3.12E-04
VS	PayInstr	tpi_debited_driver_payment_at_vehicle	=4	r	0.2	2E-04	one vehicle per 1000 per peak period	0	50		2.31E-07
VS	PMS	advanced_parking_lot_charges_request	=credit_identity+parking_lot_identity+parking_space_details+stored_credit+vehicle_identity	r	0.2	1E-04	one user per 1000 users per peak period	0	514		1.19E-06
VS	PMS	parking_lot_payment_confirmation	=confirmation_flag	r	0.2	1E-04	one vehicle per 1000 per peak period	0	26		6.02E-08
<b>TOTALS (b/s/user):</b>									<b>6.01E-01</b>	<b>2.68E-01</b>	

## CVO-Long Haul, 2012, Urbansville

PA Source	PA Sink	Data Flow	Contents	Dir	Penetration	freq	Freq. Explain	Fwd bits	Rev bits	Fwd rate (b/s/u)	Rev rate (b/s/u)
CVAS	CVCS	cv_credentials_database_update	=cv_credentials_details+cv_credentials_status_code+cv_trip_classification_data	f	0.85	9E-05	one out of 1000 vehicles per peak period	482	0	9.48E-07	
CVAS	CVCS	cv_credentials_information_response	=cv_credentials_details+cv_credentials_status_code	f	0.85	0.009	one out of 10 vehicles	410	0	8.07E-05	
CVAS	CVCS	cv_safety_database_update	=cv_credentials_details+cv_roadside_safety_data	f	1	0.001	one out of 100 vehicles	410	0	9.49E-06	
CVAS	CVCS	cv_safety_information_response	=cv_credentials_details+cv_roadside_safety_data	f	1	0.001	one out of 100 vehicles are transmitted	410	0	9.49E-06	
CVAS	FMS	cf_clearance_enrollment_confirm	=confirmation_flag	f	0.85	0.085	once per vehicle per peak period	26	0	5.12E-05	
CVAS	FMS	cf_enrollment_information	=cv_route_number+cv_taxes_and_duties+route+route_type	f	0.85	0.043	one out of two vehicles require info. per peak period	3818	0	3.76E-03	
CVAS	FMS	cf_enrollment_payment_confirmation	=cv_route_number+cv_account_number+cv_amount_billed	f	0.85	0.085	once per vehicle per peak period	170	0	3.34E-04	
CVAS	FMS	cv_enrollment_information	=cv_route_number+cv_taxes_and_duties+route+route_type	f	0.85	0.043	one out of two vehicles require info. per peak period	3818	0	3.76E-03	
CVAS	FMS	cv_enrollment_payment_confirmation	=cv_account_number+cv_amount_billed+cv_driver_credit_identity+cv_route_number	f	0.85	0.085	once per vehicle per peak period	346	0	6.81E-04	
CVCS	CVAS	cv_credentials_information_request	=cv_credentials_details+cv_credentials_request_type+cv_credentials_request_identity+cv_roadside_facility_identity	r	0.85	0.009	request info on one in ten vehicles	0	554		1.09E-04
CVCS	CVAS	cv_roadside_daily_log	=cv_roadside_facility_identity+date++cv_archived_safety_data+cv_archived_inspection_data+cv_screening_record	r	0.85	9E-04	one report per 100 vehicles per peak period	0	3362		6.62E-05
CVCS	CVAS	cv_safety_information_request	=cv_credentials_details+cv_safety_information_request_identity+cv_safety_information_request_type+cv_roadside_facility_identity	r	1	0.01	request info on one in ten vehicles	0	554		1.28E-04
CVCS	CVAS	cv_update_safety_problems_list	=cv_credentials_details+cv_roadside_facility_identity+cv_roadside_safety_data	r	1	0.001	one out of 100 vehicles are on the list per peak period	0	538		1.25E-05

## CVO-Long Haul, 2012, Urbansville

CVS	FMS	cf_driver_route_instructions_request	=cv_driver_number+cv_route_number	r	0.8	0.8	average fleet vehicle requests one route per peak period	0	154		2.85E-03
CVS	FMS	cv_driver_enrollment_payment_request	=cv_account_number+cv_driver_credit_identity+cv_route_number	r	0.85	0.85	once per vehicle per peak period	0	330		6.49E-03
CVS	FMS	cv_driver_enrollment_request	=cv_cargo_class+cv_route_number+cv_vehicle_class+cv_weight_class	r	0.85	0.85	once per vehicle per peak period	0	98		1.93E-03
CVS	FMS	cv_driver_route_request	=trip_request+route_type	r	0.8	1.6	average vehicle requests 2 routes per peak period	0	1234		4.57E-02
CVS	FMS	cv_driver_storage_request	=cv_route_number	r	0.8	0.08	one in ten vehicles per peak period	0	26		4.81E-05
CVS	FMS	cv_static_route_data	=256	r	0.8	1.6	two routes per vehicle per peak period	0	2066		7.65E-02
EM	FMS	cf_hazmat_request	=16	f	0.5	5E-05	once per 1000 vehicles per peak period	146	0	1.69E-07	
EM	VS	emergency_request_driver_acknowledge	=1	f	0.3	3E-04	one emergency per 1000 vehicles per peak period	26	0	1.81E-07	
EM	VS	emergency_request_vehicle_acknowledge	=1	f	0.3	3E-04	one emergency per 1000 vehicles per peak period	26	0	1.81E-07	
FMS	CVAS	cf_enroll_clearance_data	=cv_credentials_details	r	0.85	0.085	once per vehicle per peak period	0	402		7.91E-04
FMS	CVAS	cf_enrollment_payment_request	=cf_manager_credit_identity+cv_account_number+cv_route_number+1.5*(cv_taxes_and_duties)	r	0.85	0.085	once per vehicle per peak period	0	414		8.15E-04
FMS	CVAS	cf_enrollment_request	=cv_route_data+cv_credentials_details+cv_route_number+cv_trip_classification_data+route_type	r	0.85	0.085	once per vehicle per peak period	0	3498		6.88E-03
FMS	CVAS	cv_enrollment_payment_request	=cv_account_number+cv_driver_credit_identity+cv_route_number+1.5*(cv_taxes_and_duties)	r	0.85	0.085	once per vehicle per peak period	0	414		8.15E-04
FMS	CVAS	cv_enrollment_request	=cv_route_data+cv_credentials_details+cv_trip_classification_data+cv_route_number+route_type	r	0.85	0.085	once per vehicle per peak period	0	3498		6.88E-03
FMS	CVS	cf_driver_route_instructions	=cf_driver_route+cf_driver_load_details	f	0.8	0.8	once per vehicle per peak period	5082	0	9.41E-02	

## CVO-Long Haul, 2012, Urbansville

FMS	CVS	cv_driver_enrollment_in formation	=cv_route_number+cv_taxes_and_duties	f	0.85	0.425	one out of two vehicles require info. per peak period	82	0	8.07E-04	
FMS	CVS	cv_driver_enrollment_p ayment_confirmation	=cv_account_number+cv_amount_billed+cv_driver _credit_identity+cv_route_number	f	0.85	0.85	once per vehicle per peak period	346	0	6.81E-03	
FMS	CVS	cv_driver_route_data	=cv_route_data+route_type+cv_route_number	f	0.8	1.6	average vehicle requests two routes per peak period	3042	0	1.13E-01	
FMS	CVS	cv_static_route_request	=origin+destination+departure_time+desired_arrival _time+preferences+constraints	f	0.8	1.6	average vehicle requests two routes per peak period	1226	0	4.54E-02	
FMS	EM	cf_hazmat_route_inform ation	=cv_route_number+route	r	0.5	5E-05	once per 1000 vehicles per peak period	0	3754		4.34E-06
FMS	EM	cf_hazmat_vehicle_infor mation	=28	r	0.5	5E-05	once per 1000 vehicles per peak period	0	242		2.80E-07
FMS	ImFrgh tD	To_Intermodal_Freight_ Depot	=64	r	0.8	0.008	one in ten vehicles interacts once with an intermodal carrier	0	530		9.81E-05
FMS	ImFrgh tS	To_Intermodal_Freight_ Shipper	=64	r	0.8	0.008	one in ten vehicles interacts once with an intermodal carrier	0	530		9.81E-05
FMS	ISP	cf_route_request	=trip_request+cv_route_number	r	0.8	0.08	once per vehicle per peak period	0	1234		2.29E-03
FMS	ISP	cv_route_request	=trip_request+vehicle_identity	r	0.8	0.16	twice per vehicle per peak period	0	1354		5.01E-03
FMS	PayInstr	tpi_debited_commercial_ _manager_payment	=4	r	0.85	0.085	once per enrollment	0	50		9.84E-05
ImFrgh tD	FMS	From_Intermodal_Freig ht_Depot	=64	f	0.8	0.008	one in ten vehicles interacts once with an intermodal carrier	530	0	9.81E-05	
ImFrgh tS	FMS	From_Intermodal_Freig ht_Shipper	=64	f	0.8	0.008	one in ten vehicles interacts once with an intermodal carrier	530	0	9.81E-05	
ISP	FMS	cf_route	=cv_route_data+cv_route_number	f	0.8	0.08	once per vehicle per peak period	3034	0	5.62E-03	
ISP	FMS	cv_route	=cv_route_data+vehicle_identity	f	0.8	0.16	twice per vehicle per peak period	3154	0	1.17E-02	

## CVO-Long Haul, 2012, Urbansville

ISP	VS	advanced_fares_and_charges_response	=confirmation_flag+credit_identity+parking_lot_cost+stored_credit+transit_fare	f	0.2	2E-04	one user per 1000 users per peak period	234	0	1.08E-06	
ISP	VS	advanced_tolls_and_fares_response	=confirmation_flag+credit_identity+stored_credit+toll_cost+transit_fare	f	0.2	2E-04	one user per 1000 users per peak period	234	0	1.08E-06	
ISP	VS	advisory_data	=traffic_data_for_advisories+predicted_incidents_for_advisories+prediction_data_for_advisories+transit_services_for_advisories+transit_running_data_for_advisories	f	0.2	0.2	one set of data per peak period	6146	0	2.85E-02	
ISP	VS	yellow_pages_advisory_data	=yellow_pages_data_for_advisories+yellow_pages_cost+yellow_pages_dining_reservation_confirmation+yellow_pages_lodging_reservation_confirmation+yellow_pages_ticket_purchase_confirmation	f	0.2	0.02	one yellow pages advisory per 10 vehicles per peak period	10802	0	5.00E-03	
LocData	VS	From_Location_Data_Source	=16	f	0.3	0.03	one in ten vehicles uses once per peak period	146	0	1.01E-04	
PayInstr	FMS	fpi_commercial_manager_input_credit_identity	=12	f	0.85	0.085	once per enrollment = once per cv per peak period	114	0	2.24E-04	
PayInstr	VS	fpi_driver_vehicle_input_credit_identity	=credit_identity	f	0.2	2E-04	one vehicle per 1000 per peak period	178	0	8.24E-07	
VS	EM	emergency_request_driver_details	=date+driver_personal_emergency_request+time	r	0.3	3E-04	one emergency per 1000 vehicles per peak period	0	282		1.96E-06
VS	EM	emergency_request_vehicle_details	=date+time+vehicle_emergency_request	r	0.3	3E-04	one emergency per 1000 vehicles per peak period	0	3354		2.33E-05
VS	ISP	advanced_fares_and_charges_request	=0.6*(advanced_fare_details)+0.6*(advanced_parking_lot_charges)	r	0.2	2E-04	one user per 1000 users per peak period	0	632.4		2.93E-06
VS	ISP	advanced_tolls_and_fares_request	=0.6*(advanced_fare_details)+0.6*(advanced_tolls)	r	0.2	2E-04	one user per 1000 users per peak period	0	642		2.97E-06
VS	ISP	advisory_data_request	=advisory_data_scope+vehicle_location_for_advisories+transit_route_number+transit_vehicle_identity	r	0.2	0.4	two requests per vehicle per peak period	0	290		2.69E-03
VS	ISP	vehicle_guidance_route_accepted	=route_identity	r	0.3	0.6	two acceptances per peak period	0	34		4.72E-04

## CVO-Long Haul, 2012, Urbansville

VS	ISP	yellow_pages_advisory_requests	=advisory_data_scope+vehicle_location_for_advisories+transit_route_number+transit_vehicle_identity+yellow_pages_dining_reservation+yellow_pages_lodging_reservation+yellow_pages_ticket_purchase	r	0.2	0.02	one yellow pages advisory per 10 vehicles per peak period	0	674		3.12E-04
VS	PayInstr	tpi_debited_driver_payment_at_vehicle	=4	r	0.2	2E-04	one vehicle per 1000 per peak period	0	50		2.31E-07
VS	PMS	advanced_parking_lot_charges_request	=credit_identity+parking_lot_identity+parking_space_details+stored_credit+vehicle_identity	r	0.2	1E-04	one user per 1000 users per peak period	0	514		1.19E-06
VS	PMS	parking_lot_payment_confirmation	=confirmation_flag	r	0.2	1E-04	one vehicle per 1000 per peak period	0	26		6.02E-08
<b>TOTALS (b/s/user):</b>										<b>3.20E-01</b>	<b>1.61E-01</b>

## Transit, 2012, Urbansville

PA Source	PA Sink	Data Flow	Contents	Dire c.	Pene tration	freq	Freq. Explain	Fwd bits	Rev bits	Fwd rate (b/s/u)	Rev rate (b/s/u)
ISP	RTS	advanced_tolls_and_charges_roadside_confirm	=advanced_charges_confirm+advanced_tolls_confirm+confirmation_flag	f	0.2	6E-04	one use per 1000 transit users per peak period, or 0.032/transit vehicle	426	0	5.83E-06	
ISP	RTS	traveler_payment_confirmation	=advanced_tolls_confirm+advanced_fares_confirm+advanced_parking_lot_charges_confirm+credit_identity+kiosk_identity+stored_credit+traveler_total_trip_cost	f	0.2	6E-04	one use per 1000 transit users per peak period, or 0.032/transit vehicle	666	0	9.11E-06	
ISP	RTS	traveler_transaction_confirmation	=credit_identity+kiosk_identity+transaction_number+yellow_pages_cost+yellow_pages_lodging_reservation_confirmation+yellow_pages_dining_reservation_confirmation+yellow_pages_ticket_purchase_confirmation	f	0.2	6E-04	one use per 1000 transit users per peak period, or 0.032/transit vehicle	498	0	6.81E-06	
ISP	RTS	traveler_yellow_pages_data	=kiosk_identity+0.01*(yellow_pages_general_information+yellow_pages_specific_information+yellow_pages_transaction_information)	f	0.2	6E-04	one use per 1000 transit users per peak period, or 0.032/transit vehicle	987.7	0	1.35E-05	

## Transit, 2012, Urbansville

PayInstr	RTS	fpi_confirm_fare_payment_at_roadside	=confirmation_flag	f	0.2	0.128	one in five transit users = 6.4 per transit vehicle per peak period	26	0	7.11E-05	
PayInstr	RTS	fpi_transit_roadside_tag_data	=credit_identity	f	0.2	6E-04	one data set for 1000 users = 0.032 uses per transit vehicle per peak period	178	0	2.43E-06	
PayInstr	RTS	fpi_transit_user_roadside_input_credit_identity	=credit_identity	f	0.2	6E-04	one data set for 1000 users = 0.032 uses per transit vehicle per peak period	178	0	2.43E-06	
PayInstr	RTS	fpi_traveler_roadside_input_credit_identity	=credit_identity	f	0.2	6E-04	one data set for 1000 users = 0.032 uses per transit vehicle per peak period	178	0	2.43E-06	
PayInstr	TRVS	fpi_confirm_fare_payment_on_transit_vehicle	=confirmation_flag	f	1	32	average of one use per transit user per peak period = 32 per transit vehicle	26	0	1.78E-02	
PayInstr	TRVS	fpi_transit_vehicle_tag_data	=credit_identity	f	1	0.032	one data set for 1000 users = 0.032 uses per transit vehicle per peak period	178	0	1.22E-04	
RTS	EM	emergency_request_kiosk_traveler_details	=date+time+traveler_personal_emergency_request	r	1	0.003	one emergency per 1000 transit users per peak period, or 0.032/transit vehicle	0	370		2.53E-05
RTS	ISP	advanced_tolls_and_charges_roadside_request	=0.6*(advanced_charges)+0.6*(advanced_tolls)	r	0.2	6E-04	one use per 1000 transit users per peak period, or 0.032/transit vehicle	0	738		1.01E-05
RTS	ISP	traffic_data_kiosk_request	=kiosk_identity+traffic_data_request	r	0.2	0.64	average of one use per transit user per peak period = 32 per transit vehicle	0	98		1.34E-03
RTS	ISP	transit_deviation_kiosk_request	=kiosk_identity+transit_vehicle_deviation_request	r	0.2	0.128	one in five transit users = 6.4 per transit vehicle per peak period	0	66		1.81E-04



# Transit, 2012, Urbansville

RTS	ISP	traveler_current_conditi on_request	=kiosk_identity	r	0.2	0.64	average of one use per transit user per peak period = 32 per transit vehicle	0	58		7.93E-04
RTS	ISP	traveler_payment_infor mation	=credit_identity+kiosk_identity+parking_space_deta ils+ride_segments+stored_credit+toll_segments	r	0.2	6E-04	one use per 1000 transit users per peak period, or 0.032/transit vehicle	0	978		1.34E-05
RTS	ISP	traveler_transaction_req uest	=yellow_pages_dining_reservation+yellow_pages_l odging_reservation+yellow_pages_ticket_purchase	r	0.2	6E-04	one use per 1000 transit users per peak period, or 0.032/transit vehicle	0	402		5.50E-06
RTS	ISP	traveler_trip_confirmatio n	=paratransit_service_confirmation+traveler_identity +traveler_rideshare_confirmation	r	0.2	6E-04	one use per 1000 transit users per peak period, or 0.032/transit vehicle	0	858		1.17E-05
RTS	ISP	traveler_trip_request	=trip_request+traveler_identity+traveler_rideshare_r equest	r	0.2	6E-04	one use per 1000 transit users per peak period, or 0.032/transit vehicle	0	1434		1.96E-05
RTS	ISP	traveler_yellow_pages_i nformation_request	=1	r	0.2	6E-04	one use per 1000 transit users per peak period, or 0.032/transit vehicle	0	26		3.56E-07
RTS	PayInstr	tpi_debited_fare_payme nt_at_roadside	=4	r	0.2	0.128	one in five transit users = 6.4 per transit vehicle per peak period	0	50		1.37E-04
RTS	PayInstr	tpi_debited_transit_user _payment_at_roadside	=4	r	0.2	0.064	one in ten transit users = 3.2 per transit vehicle per peak period	0	50		6.84E-05
RTS	PayInstr	tpi_debited_traveler_pa yment_at_roadside	=4	r	0.2	6E-04	one data set for 1000 users = 0.032 uses per transit vehicle per peak period	0	50		6.84E-07
RTS	PayInstr	tpi_request_fare_payme nt_at_roadside	=2	r	0.2	6E-04	one data set for 1000 users = 0.032 uses per transit vehicle per peak period	0	34		4.65E-07
TRMS	TRVS	approved_corrective_pl an	=transit_route_corrections+transit_changes_in_stop s+transit_changes_in_speed	f	1	0.1	one corrective message per ten vehicles per peak period	8210	0	1.75E-02	

## Transit, 2012, Urbansville

TRMS	TRVS	confirm_vehicle_fare_payment	=confirmation_flag	f	1	32	average of one use per transit user per peak period = 32 per transit vehicle	26	0	1.78E-02
TRMS	TRVS	other_services_vehicle_response	=traveler_identity+credit_identity+other_services_data	f	0.2	0.006	one data set for 1000 users = 0.032 uses per transit vehicle per peak period	2418	0	3.31E-04
TRMS	TRVS	paratransit_transit_driver_instructions	=128	f	1	13	dispatch message every 15 min. during peak period=48/4(ratio of paratr/tr veh)	1042	0	2.89E-01
TRMS	TRVS	request_transit_user_image	=8	f	1	0.032	one image for 1000 users = 0.032 uses per transit vehicle per peak period	82	0	5.61E-05
TRMS	TRVS	transit_operator_request_acknowledge	=2	f	1	0.032	one data set for 1000 users = 0.032 uses per transit vehicle per peak period	34	0	2.32E-05
TRMS	TRVS	transit_services_for_corrections	=list_size+1*(2/NUM_TRANSIT_ROUTES)*(transit_services)	f	1	13	one correction per hour during the peak period	17260	0	4.79E+00
TRMS	TRVS	transit_services_for_eta	=transit_route_number+transit_route_segment_list+transit_route_stop_list	f	1	52	update every 15 minutes during the peak period	7786	0	8.65E+00
TRMS	TRVS	transit_services_for_vehicle_fares	=transit_route_fare_data	f	1	1	update daily during peak period	16826	0	3.60E-01
TRMS	TRVS	transit_vehicle_advanced_payment_response	=advanced_charges_confirm+advanced_tolls_confirm+confirmation_flag+transit_vehicle_identity	f	1	0.032	one data set for 1000 users = 0.032 uses per transit vehicle per peak period	554	0	3.79E-04
TRMS	TRVS	transit_vehicle_fare_data	=transit_fares	f	1	1	updated once per peak period per transit vehicle	922	0	1.97E-02
TRMS	TRVS	transit_vehicle_fare_payment_debited	=confirmation_flag	f	1	32	average of one use per transit user per peak period = 32 per transit vehicle	26	0	1.78E-02
TRMS	TRVS	transit_vehicle_fare_payment_request	=transit_fare	f	1	32	average of one use per transit user per peak period = 32 per transit vehicle	34	0	2.32E-02

## Transit, 2012, Urbansville

TRVS	PayInstr	tpi_debited_payment_on_transit_vehicle	=4	f	1	32	average of one use per transit user per peak period = 32 per transit vehicle	50	0	3.42E-02	
TRVS	PayInstr	tpi_request_fare_payment_on_transit_vehicle	=2	f	1	32	average of one use per transit user per peak period = 32 per transit vehicle	34	0	2.32E-02	
TRVS	TRMS	other_services_vehicle_request	=traveler_identity+credit_identity+other_services_data	r	0.2	0.006	one data set for 1000 users = 0.032 uses per transit vehicle per peak period	0	2418		3.31E-04
TRVS	TRMS	paratransit_transit_vehicle_availability	=1	r	1	13	avail. message every 15 min. during peak period=48/4(ratio of paratr/tr veh)	0	26		7.22E-03
TRVS	TRMS	request_vehicle_fare_payment	=credit_identity+transit_fare+transit_route_number+transit_route_segment_number+transit_route_use_time+transit_user_category+traveler_identity	r	1	32	average of one use per peak period per transit user = 32 per transit vehicle	0	466		3.19E-01
TRVS	TRMS	transit_conditions_request	=2	r	1	0.1	one corrective message per ten vehicles per peak period	0	34		7.26E-05
TRVS	TRMS	transit_emergency_details	=transit_driver_emergency_request+transit_user_emergency_request+transit_vehicle_location	r	1	0.003	emergency for one in 10000 transit users=0.0032 per transit vehicle per peak	0	282		1.93E-05
TRVS	TRMS	transit_emergency_information	=transit_driver_emergency_request+transit_user_emergency_request+transit_vehicle_location	r	1	0.003	emergency for one in 10000 transit users=0.0032 per transit vehicle per peak	0	282		1.93E-05
TRVS	TRMS	transit_operator_emergency_request	=128	r	1	0.003	emergency for one in 10000 transit users=0.0032 per transit vehicle per peak	0	1042		7.12E-05
TRVS	TRMS	transit_services_for_eta_request	=transit_vehicle_identity+transit_route_number+transit_route_schedule_number	r	1	3.2	average of one use per 10 transit users per peak period=3.2 per transit vehicle	0	186		1.27E-02

Transit, 2012, Urbansville											
TRVS	TRMS	transit_user_vehicle_image	=JPEG*(ftu_transit_user_vehicle_image)	r	1	0.011	20 images per metro area per peak period=20/1788 transit vehicles	0	73746		1.73E-02
TRVS	TRMS	transit_vehicle_advanced_payment_request	=advanced_charges+advanced_tolls+transit_vehicle_location	r	0.2	0.006	one data set for 1000 users = 0.032 uses per transit vehicle per peak period	0	1450		1.98E-04
TRVS	TRMS	transit_vehicle_arrival_conditions	=128	r	1	13	updated every 60 minutes during the peak period	0	1042		2.89E-01
TRVS	TRMS	transit_vehicle_collected_trip_data	=transit_vehicle_passenger_loading+transit_vehicle_running_times	r	1	13	every hour for each transit vehicle per peak period	0	1826		5.07E-01
TRVS	TRMS	transit_vehicle_deviations_from_schedule	=32	r	1	52	update every 15 minutes during the peak period	0	274		3.04E-01
TRVS	TRMS	transit_vehicle_eta	=transit_vehicle_identity+transit_vehicle_time+transit_route_number	r	1	156	updated every 5 minutes during the peak period	0	234		7.80E-01
TRVS	TRMS	transit_vehicle_fare_payment_confirmation	=confirmation_flag	r	1	32	average of one use per transit user per peak period = 32 per transit vehicle	0	26		1.78E-02
TRVS	TRMS	transit_vehicle_location	=transit_vehicle_identity+transit_vehicle_location_data	r	1	52	updated every 15 minutes during the peak period	0	250		2.78E-01
TRVS	TRMS	transit_vehicle_location_for_deviation	=transit_vehicle_identity+transit_vehicle_location_data	r	1	52	updated every 15 minutes during the peak period	0	250		2.78E-01
TRVS	TRMS	transit_vehicle_location_for_store	=transit_vehicle_identity+transit_vehicle_location_data	r	1	13	updated every 60 minutes during the peak period	0	250		6.94E-02
TRVS	TRMS	transit_vehicle_passenger_data	=transit_passenger_numbers+transit_route_number+transit_route_segment_number+transit_route_use_time+transit_user_category+transit_vehicle_identity	r	1	52	update every 15 minutes during the peak period	0	242		2.69E-01
TRVS	TRMS	transit_vehicle_schedule_deviation	=32	r	1	52	updated every 15 minutes during the peak period	0	274		3.04E-01
<b>TOTALS (b/s/user):</b>									<b>1.43E+01</b>	<b>3.46E+00</b>	

## Emergency Management, 2102, Urbansville

PA Source	PA Sink	Data Flow	Contents	Dir c.	Pene trati on	freq	Freq. Explain	Fwd bits	Rev bits	Fwd rate (b/s/u)	Rev rate (b/s/u)
EM	EVS	emergency_vehicle_driver_outputs	=128	f	1	13	average one driver output per vehicle per hour during the peak period	1042	0	2.89E-01	
EVS	EM	emergency_driver_dispatch_acknowledge	=1	r	1	26	average one dispatch acknowledge per vehicle per 1/2 hour during the peak period	0	26		1.44E-02
EVS	EM	emergency_driver_statuses_update	=16	r	1	26	average one status update per vehicle per 1/2 hour during the peak period	0	146		8.11E-02
EVS	EM	emergency_vehicle_driver_inputs	=64	r	1	13	average one driver input per vehicle per hour during the peak period	0	530		1.47E-01
<b>TOTALS (b/s/user):</b>										<b>2.89E-01</b>	<b>2.43E-01</b>

<b>Probes, 2012, Urbansville</b>											
PA Source	PA Sink	Data Flow	Contents	Dir c.	Pen e tra tion	freq	Freq. Explain	Fwd bits	Rev bits	Fwd rate (b/s/u)	Rev rate (b/s/u)
VS	ISP	vehicle_guidance_probe_data	=route_segment_identity+vehicle_identity	r	1	12	average of 12 probe reports per vehicle per peak period	0	314		1.74E-01
<b>TOTALS (b/s/user):</b>										<b>0.00E+00</b>	<b>1.74E-01</b>

## Private Vehicle, 2012, Thruville

PA Source	PA Sink	Data Flow	Contents	Dir	Penetration	freq	Freq. Explain	Fwd bits	Rev bits	Fwd rate (b/s/u)	Rev rate (b/s/u)
EM	VS	emergency_request_driver_acknowledge	=1	f	0.3	3E-04	one emergency per 1000 vehicles per peak period	26	0	3.61E-07	
EM	VS	emergency_request_vehicle_acknowledge	=1	f	0.3	3E-04	one emergency per 1000 vehicles per peak period	26	0	3.61E-07	
LocData	VS	From_Location_Data_Source	=16	f	0.3	0.03	one in ten vs uses per peak period	146	0	2.03E-04	
PayInstr	VS	fpi_transit_user_vehicle_input_credit_identity	=credit_identity	f	1	1E-04	one in 10000 vehicles uses this flow per peak period	178	0	8.24E-07	
VS	EM	emergency_request_driver_details	=date+driver_personal_emergency_request+time	r	0.3	3E-04	one emergency per 1000 vehicles per peak period	0	282		3.92E-06
VS	EM	emergency_request_vehicle_details	=date+time+vehicle_emergency_request	r	0.3	3E-04	one emergency per 1000 vehicles per peak period	0	3354		4.66E-05
VS	ISP	advisory_data_request	=advisory_data_scope+vehicle_location_for_advisories+transit_route_number+transit_vehicle_identity	r	0.2	0.2	one request per vehicle per peak period	0	290		2.69E-03
VS	ISP	vehicle_guidance_route_accepted	=route_identity	r	0.3	0.6	two acceptances per peak period	0	34		9.44E-04
<b>TOTALS (b/s/user):</b>										<b>2.04E-04</b>	<b>3.68E-03</b>

## Traveler, 2012, Thruville

PA Source	PA Sink	Data Flow	Contents	Dir	Penetration	freq	Freq. Explain	Fwd bits	Rev bits	Fwd rate (b/s/u)	Rev rate (b/s/u)
EM	PIAS	emergency_request_personal_traveler_acknowledge	=confirmation_flag	f	0.3	8E-05	one emergency per 2000 users in peak period	26	0	9.03E-08	
ISP	PIAS	transit_deviations_for_portables	=traveler_identity+list_size+TRANSIT_SEGS*(transit_vehicle_identity+transit_vehicle_achieved_time+transit_route_segment_number)	f	0.2	5E-04	one request per 20 pias per peak period	3578	0	8.28E-05	
ISP	PIAS	traveler_guidance_route	=route_identity+traveler_route+traveler_identity	f	0.3	0.015	one route per day per pias	18306	0	1.27E-02	
LocData	PIAS	From_Location_Data_Source	=16	f	0.3	0.03	one in ten pias uses per peak period	146	0	2.03E-04	
PIAS	EM	emergency_request_personal_traveler_details	=date+time+traveler_personal_emergency_request	r	0.3	8E-05	one emergency per 2000 users in peak period	0	370		1.28E-06
PIAS	ISP	traffic_data_portables_request	=traffic_data_request+traveler_identity	r	0.2	0.1	one request per pias per peak period	0	250		1.16E-03
PIAS	ISP	transit_deviations_portables_request	=traveler_identity+transit_vehicle_deviation_request+transit_route_number	r	0.2	0.005	one request per 20 pias per peak period	0	250		5.79E-05
<b>TOTALS (b/s/user):</b>										<b>1.30E-02</b>	<b>1.22E-03</b>



## CVO-Local, 2012, Thruville

PA Source	PA Sink	Data Flow	Contents	Dir	Penetration	freq	Freq. Explain	Fwd bits	Rev bits	Fwd rate (b/s/u)	Rev rate (b/s/u)
CVS	FMS	cf_driver_route_instructions_request	=cv_driver_number+cv_route_number	r	0.8	1.6	average fleet vehicle requests two routes per peak period	0	154		5.70E-03
CVS	FMS	cv_driver_route_request	=trip_request+route_type	r	0.8	3.2	average vehicle requests 4 routes per peak period	0	1234		9.14E-02
CVS	FMS	cv_driver_storage_request	=cv_route_number	r	0.8	0.08	one in ten vehicles per peak period	0	26		4.81E-05
CVS	FMS	cv_static_route_data	=256	r	0.8	3.2	four routes per vehicle per peak period	0	2066		1.53E-01
EM	FMS	cf_hazmat_request	=16	f	0.5	5E-05	once per 1000 vehicles per peak period	146	0	1.69E-07	
EM	VS	emergency_request_driver_acknowledge	=1	f	0.3	3E-04	one emergency per 1000 vehicles per peak period	26	0	1.81E-07	
EM	VS	emergency_request_vehicle_acknowledge	=1	f	0.3	3E-04	one emergency per 1000 vehicles per peak period	26	0	1.81E-07	
FMS	CVS	cf_driver_route_instructions	=cf_driver_route+cf_driver_load_details	f	0.8	1.6	twice per vehicle per peak period	5082	0	1.88E-01	
FMS	CVS	cv_driver_route_data	=cv_route_data+route_type+cv_route_number	f	0.8	3.2	average vehicle requests four routes per peak period	3042	0	2.25E-01	
FMS	CVS	cv_static_route_request	=origin+destination+departure_time+desired_arrival_time+preferences+constraints	f	0.8	3.2	average vehicle requests four routes per peak period	1226	0	9.08E-02	
FMS	EM	cf_hazmat_route_information	=cv_route_number+route	r	0.5	5E-05	once per 1000 vehicles per peak period	0	3754		4.34E-06
FMS	EM	cf_hazmat_vehicle_information	=28	r	0.5	5E-05	once per 1000 vehicles per peak period	0	242		2.80E-07
FMS	ImFrghD	To_Intermodal_Freight_Depot	=64	r	0.8	0.008	one in ten of vehicles interact once with an intermodal carrier	0	530		9.81E-05
FMS	ImFrghS	To_Intermodal_Freight_Shipper	=64	r	0.8	0.008	one in ten of vehicles interact once with an intermodal carrier	0	530		9.81E-05

## CVO-Local, 2012, Thruville

FMS	ISP	cf_route_request	=trip_request+cv_route_number	r	0.8	0.16	twice per vehicle per peak period	0	1234		4.57E-03	
FMS	ISP	cv_route_request	=trip_request+vehicle_identity	r	0.8	0.32	four times per vehicle per peak period	0	1354		1.00E-02	
ImFrghtD	FMS	From_Intermodal_Freight_Depot	=64	f	0.8	0.008	one in ten of vehicles interact once with an intermodal carrier	530	0	9.81E-05		
ImFrghtS	FMS	From_Intermodal_Freight_Shipper	=64	f	0.8	0.008	one in ten of vehicles interact once with an intermodal carrier	530	0	9.81E-05		
ISP	FMS	cf_route	=cv_route_data+cv_route_number	f	0.8	0.16	twice per vehicle per peak period	3034	0	1.12E-02		
ISP	FMS	cv_route	=cv_route_data+vehicle_identity	f	0.8	0.32	four times per vehicle per peak period	3154	0	2.34E-02		
LocData	VS	From_Location_Data_Source	=16	f	0.3	0.03	one in ten vehicles uses once per peak period	146	0	1.01E-04		
VS	EM	emergency_request_driver_details	=date+driver_personal_emergency_request+time	r	0.3	3E-04	one emergency per 1000 vehicles per peak period	0	282		1.96E-06	
VS	EM	emergency_request_vehicle_details	=date+time+vehicle_emergency_request	r	0.3	3E-04	one emergency per 1000 vehicles per peak period	0	3354		2.33E-05	
VS	ISP	advisory_data_request	=advisory_data_scope+vehicle_location_for_advisories+transit_route_number+transit_vehicle_identity	r	0.2	0.4	two requests per vehicle per peak period	0	290		2.69E-03	
<b>TOTALS (b/s/user):</b>											<b>5.39E-01</b>	<b>2.68E-01</b>

## CVO-Long Haul, 2012, Thruville

PA Source	PA Sink	Data Flow	Contents	Dir	Penetration	freq	Freq. Explain	Fwd bits	Rev bits	Fwd rate (b/s/u)	Rev rate (b/s/u)
CVAS	CVCS	cv_credentials_database_update	=cv_credentials_details+cv_credentials_status_code+cv_trip_classification_data	f	0.85	9E-05	one out of 1000 vehicles per peak period	482	0	9.48E-07	
CVAS	CVCS	cv_credentials_information_response	=cv_credentials_details+cv_credentials_status_code	f	0.85	0.009	one out of 10 vehicles	410	0	8.07E-05	
CVAS	CVCS	cv_safety_database_update	=cv_credentials_details+cv_roadside_safety_data	f	1	0.001	one out of 100 vehicles	410	0	9.49E-06	
CVAS	CVCS	cv_safety_information_response	=cv_credentials_details+cv_roadside_safety_data	f	1	0.001	one out of 100 vehicles are transmitted	410	0	9.49E-06	
CVAS	FMS	cf_clearance_enrollment_confirm	=confirmation_flag	f	0.85	0.085	once per vehicle per peak period	26	0	5.12E-05	
CVAS	FMS	cf_enrollment_information	=cv_route_number+cv_taxes_and_duties+route+route_type	f	0.85	0.043	one out of two vehicles require info. per peak period	3818	0	3.76E-03	
CVAS	FMS	cf_enrollment_payment_confirmation	=cv_route_number+cv_account_number+cv_amount_billed	f	0.85	0.085	once per vehicle per peak period	170	0	3.34E-04	
CVAS	FMS	cv_enrollment_information	=cv_route_number+cv_taxes_and_duties+route+route_type	f	0.85	0.043	one out of two vehicles require info. per peak period	3818	0	3.76E-03	
CVAS	FMS	cv_enrollment_payment_confirmation	=cv_account_number+cv_amount_billed+cv_driver_credit_identity+cv_route_number	f	0.85	0.085	once per vehicle per peak period	346	0	6.81E-04	
CVCS	CVAS	cv_credentials_information_request	=cv_credentials_details+cv_credentials_request_type+cv_credentials_request_identity+cv_roadside_facility_identity	r	0.85	0.009	request info on one in ten vehicles	0	554		1.09E-04
CVCS	CVAS	cv_roadside_daily_log	=cv_roadside_facility_identity+date++cv_archived_safety_data+cv_archived_inspection_data+cv_screening_record	r	0.85	9E-04	one report per 100 vehicles per peak period	0	3362		6.62E-05
CVCS	CVAS	cv_safety_information_request	=cv_credentials_details+cv_safety_information_request_identity+cv_safety_information_request_type+cv_roadside_facility_identity	r	1	0.01	request info on one in ten vehicles	0	554		1.28E-04
CVCS	CVAS	cv_update_safety_problems_list	=cv_credentials_details+cv_roadside_facility_identity+cv_roadside_safety_data	r	1	0.001	one out of 100 vehicles are on the list per peak period	0	538		1.25E-05

## CVO-Long Haul, 2012, Thruville

CVS	FMS	cf_driver_route_instructions_request	=cv_driver_number+cv_route_number	r	0.8	0.8	average fleet vehicle requests one route per peak period	0	154		2.85E-03
CVS	FMS	cv_driver_enrollment_payment_request	=cv_account_number+cv_driver_credit_identity+cv_route_number	r	0.85	0.85	once per vehicle per peak period	0	330		6.49E-03
CVS	FMS	cv_driver_enrollment_request	=cv_cargo_class+cv_route_number+cv_vehicle_class+cv_weight_class	r	0.85	0.85	once per vehicle per peak period	0	98		1.93E-03
CVS	FMS	cv_driver_route_request	=trip_request+route_type	r	0.8	1.6	average vehicle requests 2 routes per peak period	0	1234		4.57E-02
CVS	FMS	cv_driver_storage_request	=cv_route_number	r	0.8	0.08	one in ten vehicles per peak period	0	26		4.81E-05
CVS	FMS	cv_static_route_data	=256	r	0.8	1.6	two routes per vehicle per peak period	0	2066		7.65E-02
EM	FMS	cf_hazmat_request	=16	f	0.5	5E-05	once per 1000 vehicles per peak period	146	0	1.69E-07	
EM	VS	emergency_request_driver_acknowledge	=1	f	0.3	3E-04	one emergency per 1000 vehicles per peak period	26	0	1.81E-07	
EM	VS	emergency_request_vehicle_acknowledge	=1	f	0.3	3E-04	one emergency per 1000 vehicles per peak period	26	0	1.81E-07	
FMS	CVAS	cf_enroll_clearance_data	=cv_credentials_details	r	0.85	0.085	once per vehicle per peak period	0	402		7.91E-04
FMS	CVAS	cf_enrollment_payment_request	=cf_manager_credit_identity+cv_account_number+cv_route_number+1.5*(cv_taxes_and_duties)	r	0.85	0.085	once per vehicle per peak period	0	414		8.15E-04
FMS	CVAS	cf_enrollment_request	=cv_route_data+cv_credentials_details+cv_route_number+cv_trip_classification_data+route_type	r	0.85	0.085	once per vehicle per peak period	0	3498		6.88E-03
FMS	CVAS	cv_enrollment_payment_request	=cv_account_number+cv_driver_credit_identity+cv_route_number+1.5*(cv_taxes_and_duties)	r	0.85	0.085	once per vehicle per peak period	0	414		8.15E-04
FMS	CVAS	cv_enrollment_request	=cv_route_data+cv_credentials_details+cv_trip_classification_data+cv_route_number+route_type	r	0.85	0.085	once per vehicle per peak period	0	3498		6.88E-03
FMS	CVS	cf_driver_route_instructions	=cf_driver_route+cf_driver_load_details	f	0.8	0.8	once per vehicle per peak period	5082	0	9.41E-02	

## CVO-Long Haul, 2012, Thruville

FMS	CVS	cv_driver_enrollment_in formation	=cv_route_number+cv_taxes_and_duties	f	0.85	0.425	one out of two vehicles require info. per peak period	82	0	8.07E-04	
FMS	CVS	cv_driver_enrollment_p ayment_confirmation	=cv_account_number+cv_amount_billed+cv_driver _credit_identity+cv_route_number	f	0.85	0.85	once per vehicle per peak period	346	0	6.81E-03	
FMS	CVS	cv_driver_route_data	=cv_route_data+route_type+cv_route_number	f	0.8	1.6	average vehicle requests two routes per peak period	3042	0	1.13E-01	
FMS	CVS	cv_static_route_request	=origin+destination+departure_time+desired_arrival _time+preferences+constraints	f	0.8	1.6	average vehicle requests two routes per peak period	1226	0	4.54E-02	
FMS	EM	cf_hazmat_route_inform ation	=cv_route_number+route	r	0.5	5E-05	once per 1000 vehicles per peak period	0	3754		4.34E-06
FMS	EM	cf_hazmat_vehicle_infor mation	=28	r	0.5	5E-05	once per 1000 vehicles per peak period	0	242		2.80E-07
FMS	ImFrgh tD	To_Intermodal_Freight_ Depot	=64	r	0.8	0.008	one in ten vehicles interacts once with an intermodal carrier	0	530		9.81E-05
FMS	ImFrgh tS	To_Intermodal_Freight_ Shipper	=64	r	0.8	0.008	one in ten vehicles interacts once with an intermodal carrier	0	530		9.81E-05
FMS	ISP	cf_route_request	=trip_request+cv_route_number	r	0.8	0.08	once per vehicle per peak period	0	1234		2.29E-03
FMS	ISP	cv_route_request	=trip_request+vehicle_identity	r	0.8	0.16	twice per vehicle per peak period	0	1354		5.01E-03
FMS	PayInstr	tpi_debited_commercial_ _manager_payment	=4	r	0.85	0.085	once per enrollment	0	50		9.84E-05
ImFrgh tD	FMS	From_Intermodal_Freig ht_Depot	=64	f	0.8	0.008	one in ten vehicles interacts once with an intermodal carrier	530	0	9.81E-05	
ImFrgh tS	FMS	From_Intermodal_Freig ht_Shipper	=64	f	0.8	0.008	one in ten vehicles interacts once with an intermodal carrier	530	0	9.81E-05	
ISP	FMS	cf_route	=cv_route_data+cv_route_number	f	0.8	0.08	once per vehicle per peak period	3034	0	5.62E-03	
ISP	FMS	cv_route	=cv_route_data+vehicle_identity	f	0.8	0.16	twice per vehicle per peak period	3154	0	1.17E-02	

## CVO-Long Haul, 2012, Thruville

LocData	VS	From_Location_Data_S ource	=16	f	0.3	0.03	one in ten vehicles uses once per peak period	146	0	1.01E-04	
PayInstr	FMS	fpi_commercial_manag er_input_credit_identity	=12	f	0.85	0.085	once per enrollment = once per cv per peak period	114	0	2.24E-04	
VS	EM	emergency_request_dri ver_details	=date+driver_personal_emergency_request+time	r	0.3	3E-04	one emergency per 1000 vehicles per peak period	0	282		1.96E-06
VS	EM	emergency_request_ve hicle_details	=date+time+vehicle_emergency_request	r	0.3	3E-04	one emergency per 1000 vehicles per peak period	0	3354		2.33E-05
VS	ISP	advisory_data_request	=advisory_data_scope+vehicle_location_for_adviso ries+transit_route_number+transit_vehicle_identity	r	0.2	0.4	two requests per vehicle per peak period	0	290		2.69E-03
VS	ISP	vehicle_guidance_route _accepted	=route_identity	r	0.3	0.6	two acceptances per peak period	0	34		4.72E-04
<b>TOTALS (b/s/user):</b>										<b>2.86E-01</b>	<b>1.61E-01</b>

## Transit, 2012, Thruville

PA Source	PA Sink	Data Flow	Contents	Dir ec.	Penetration	freq	Freq. Explain	Fwd bits	Rev bits	Fwd rate (b/s/u)	Rev rate (b/s/u)
PayInstr	TRVS	fpi_confirm_fare_payment_on_transit_vehicle	=confirmation_flag	f	1	32	average of one use per transit user per peak period = 32 per transit vehicle	26	0	1.78E-02	
PayInstr	TRVS	fpi_transit_vehicle_tag_data	=credit_identity	f	1	0.032	one data set for 1000 users = 0.032 uses per transit vehicle per peak period	178	0	1.22E-04	
RTS	ISP	traffic_data_kiosk_request	=kiosk_identity+traffic_data_request	r	0.2	0.64	average of one use per transit user per peak period = 32 per transit vehicle	0	98		1.34E-03
RTS	ISP	transit_deviation_kiosk_request	=kiosk_identity+transit_vehicle_deviation_request	r	0.2	0.128	one in five transit users = 6.4 per transit vehicle per peak period	0	66		1.81E-04
RTS	ISP	traveler_current_condition_request	=kiosk_identity	r	0.2	0.64	average of one use per transit user per peak period = 32 per transit vehicle	0	58		7.93E-04
TRMS	TRVS	approved_corrective_plan	=transit_route_corrections+transit_changes_in_stops+transit_changes_in_speed	f	1	0.1	one corrective message per ten vehicles per peak period	8210	0	1.75E-02	
TRMS	TRVS	confirm_vehicle_fare_payment	=confirmation_flag	f	1	32	average of one use per transit user per peak period = 32 per transit vehicle	26	0	1.78E-02	
TRMS	TRVS	paratransit_transit_driver_instructions	=128	f	1	13	dispatch message every 15 min. during peak period=48/4(ratio of paratr/tr veh)	1042	0	2.89E-01	
TRMS	TRVS	request_transit_user_image	=8	f	1	0.032	one image for 1000 users = 0.032 uses per transit vehicle per peak period	82	0	5.61E-05	
TRMS	TRVS	transit_services_for_corrections	=list_size+1*(2/NUM_TRANSIT_ROUTES)*(transit_services)	f	1	13	one correction per hour during the peak period	17260	0	4.79E+00	

## Transit, 2012, Thruville

TRMS	TRVS	transit_services_for_eta	=transit_route_number+transit_route_segment_list+transit_route_stop_list	f	1	52	update every 15 minutes during the peak period	7786	0	8.65E+00	
TRMS	TRVS	transit_services_for_vehicle_fares	=transit_route_fare_data	f	1	1	update daily during peak period	16826	0	3.60E-01	
TRMS	TRVS	transit_vehicle_advance_d_payment_response	=advanced_charges_confirm+advanced_tolls_confirm+confirmation_flag+transit_vehicle_identity	f	1	0.032	one data set for 1000 users = 0.032 uses per transit vehicle per peak period	554	0	3.79E-04	
TRMS	TRVS	transit_vehicle_fare_data	=transit_fares	f	1	1	updated once per peak period per transit vehicle	922	0	1.97E-02	
TRMS	TRVS	transit_vehicle_fare_payment_debited	=confirmation_flag	f	1	32	average of one use per transit user per peak period = 32 per transit vehicle	26	0	1.78E-02	
TRMS	TRVS	transit_vehicle_fare_payment_request	=transit_fare	f	1	32	average of one use per transit user per peak period = 32 per transit vehicle	34	0	2.32E-02	
TRVS	PayInstr	tpi_debited_payment_on_transit_vehicle	=4	f	1	32	average of one use per transit user per peak period = 32 per transit vehicle	50	0	3.42E-02	
TRVS	PayInstr	tpi_request_fare_payment_on_transit_vehicle	=2	f	1	32	average of one use per transit user per peak period = 32 per transit vehicle	34	0	2.32E-02	
TRVS	TRMS	paratransit_transit_vehicle_availability	=1	r	1	13	avail. message every 15 min. during peak period=48/4(ratio of paratr/tr veh)	0	26		7.22E-03
TRVS	TRMS	request_vehicle_fare_payment	=credit_identity+transit_fare+transit_route_number+transit_route_segment_number+transit_route_use_time+transit_user_category+traveler_identity	r	1	32	average of one use per peak period per transit user = 32 per transit vehicle	0	466		3.19E-01
TRVS	TRMS	transit_conditions_request	=2	r	1	0.1	one corrective message per ten vehicles per peak period	0	34		7.26E-05



Transit, 2012, Thruville											
TRVS	TRMS	transit_services_for_eta_request	=transit_vehicle_identity+transit_route_number+transit_route_schedule_number	r	1	3.2	average of one use per 10 transit users per peak period=3.2 per transit vehicle	0	186		1.27E-02
TRVS	TRMS	transit_user_vehicle_image	=JPEG*(ftu_transit_user_vehicle_image)	r	1	0.011	20 images per metro area per peak period=20/1788 transit vehicles	0	73746		1.73E-02
TRVS	TRMS	transit_vehicle_arrival_conditions	=128	r	1	13	updated every 60 minutes during the peak period	0	1042		2.89E-01
TRVS	TRMS	transit_vehicle_collected_trip_data	=transit_vehicle_passenger_loading+transit_vehicle_running_times	r	1	13	every hour for each transit vehicle per peak period	0	1826		5.07E-01
TRVS	TRMS	transit_vehicle_deviations_from_schedule	=32	r	1	52	update every 15 minutes during the peak period	0	274		3.04E-01
TRVS	TRMS	transit_vehicle_eta	=transit_vehicle_identity+transit_vehicle_time+transit_route_number	r	1	156	updated every 5 minutes during the peak period	0	234		7.80E-01
TRVS	TRMS	transit_vehicle_fare_payment_confirmation	=confirmation_flag	r	1	32	average of one use per transit user per peak period = 32 per transit vehicle	0	26		1.78E-02
TRVS	TRMS	transit_vehicle_location	=transit_vehicle_identity+transit_vehicle_location_data	r	1	52	updated every 15 minutes during the peak period	0	250		2.78E-01
TRVS	TRMS	transit_vehicle_location_for_deviation	=transit_vehicle_identity+transit_vehicle_location_data	r	1	52	updated every 15 minutes during the peak period	0	250		2.78E-01
TRVS	TRMS	transit_vehicle_location_for_store	=transit_vehicle_identity+transit_vehicle_location_data	r	1	13	updated every 60 minutes during the peak period	0	250		6.94E-02
TRVS	TRMS	transit_vehicle_passenger_data	=transit_passenger_numbers+transit_route_number+transit_route_segment_number+transit_route_use_time+transit_user_category+transit_vehicle_identity	r	1	52	update every 15 minutes during the peak period	0	242		2.69E-01
TRVS	TRMS	transit_vehicle_schedule_deviation	=32	r	1	52	updated every 15 minutes during the peak period	0	274		3.04E-01
<b>TOTALS (b/s/user):</b>									<b>1.43E+01</b>	<b>3.46E+00</b>	

## Emergency Management, 2012, Thruville

PA Source	PA Sink	Data Flow	Contents	Dir c.	Pen etra tion	freq	Freq. Explain	Fwd bits	Rev bits	Fwd rate (b/s/u)	Rev rate (b/s/u)
EM	EVS	emergency_vehicle_driver_outputs	=128	f	1	13	average one driver output per vehicle per hour during the peak period	1042	0	2.89E-01	
EVS	EM	emergency_driver_dispatch_acknowledge	=1	r	1	26	average one dispatch acknowledge per vehicle per 1/2 hour during the peak period	0	26		1.44E-02
EVS	EM	emergency_driver_status_update	=16	r	1	26	average one status update per vehicle per 1/2 hour during the peak period	0	146		8.11E-02
EVS	EM	emergency_vehicle_driver_inputs	=64	r	1	13	average one driver input per vehicle per hour during the peak period	0	530		1.47E-01
<b>TOTALS (b/s/user):</b>										<b>2.89E-01</b>	<b>2.43E-01</b>

## Probes, 2012, Thruville

PA Source	PA Sink	Data Flow	Contents	Dir c.	Pen etra tion	freq	Freq. Explain	Fwd bits	Rev bits	Fwd rate (b/s/u)	Rev rate (b/s/u)
VS	ISP	vehicle_guidance_probe_data	=route_segment_identity+vehicle_identity	r	1	12	average of 12 probe reports per vehicle per peak period	0	314		1.74E-01
<b>TOTALS (b/s/user):</b>										<b>0.00E+00</b>	<b>1.74E-01</b>

## Private Vehicle, 2012, Mountainville

PA Source	PA Sink	Data Flow	Contents	Dir	Penetration	freq	Freq. Explain	Fwd bits	Rev bits	Fwd rate (b/s/u)	Rev rate (b/s/u)
EM	VS	emergency_request_driver_acknowledge	=1	f	0.3	3E-04	one emergency per 1000 vehicles per peak period	26	0	3.61E-07	
EM	VS	emergency_request_vehicle_acknowledge	=1	f	0.3	3E-04	one emergency per 1000 vehicles per peak period	26	0	3.61E-07	
ISP	VS	advanced_fares_and_charges_response	=confirmation_flag+credit_identity+parking_lot_cost+stored_credit+transit_fare	f	0.2	2E-04	one user per 1000 users per peak period	234	0	2.17E-06	
ISP	VS	advanced_tolls_and_fares_response	=confirmation_flag+credit_identity+stored_credit+toll_cost+transit_fare	f	0.2	2E-04	one user per 1000 users per peak period	234	0	2.17E-06	
ISP	VS	advisory_data	=traffic_data_for_advisories+predicted_incidents_for_advisories+prediction_data_for_advisories+transit_services_for_advisories+transit_running_data_for_advisories	f	0.2	0.2	one set of data per peak period	6146	0	5.69E-02	
ISP	VS	yellow_pages_advisory_data	=yellow_pages_data_for_advisories+yellow_pages_cost+yellow_pages_dining_reservation_confirmation+yellow_pages_lodging_reservation_confirmation+yellow_pages_ticket_purchase_confirmation	f	0.2	0.02	one yellow pages advisory per 10 vehicles per peak period	10802	0	1.00E-02	
LocData	VS	From_Location_Data_Source	=16	f	0.3	0.03	one in ten vs uses per peak period	146	0	2.03E-04	
PayInstr	VS	fpi_driver_vehicle_input_credit_identity	=credit_identity	f	0.2	2E-04	one vehicle per 1000 per peak period	178	0	1.65E-06	
PayInstr	VS	fpi_transit_user_vehicle_input_credit_identity	=credit_identity	f	1	1E-04	one in 10000 vehicles uses this flow per peak period	178	0	8.24E-07	
VS	EM	emergency_request_driver_details	=date+driver_personal_emergency_request+time	r	0.3	3E-04	one emergency per 1000 vehicles per peak period	0	282		3.92E-06
VS	EM	emergency_request_vehicle_details	=date+time+vehicle_emergency_request	r	0.3	3E-04	one emergency per 1000 vehicles per peak period	0	3354		4.66E-05
VS	ISP	advanced_fares_and_charges_request	=0.6*(advanced_fare_details)+0.6*(advanced_parking_lot_charges)	r	0.2	2E-04	one user per 1000 users per peak period	0	632.4		5.86E-06
VS	ISP	advanced_tolls_and_fares_request	=0.6*(advanced_fare_details)+0.6*(advanced_tolls)	r	0.2	2E-04	one user per 1000 users per peak period	0	642		5.94E-06

## Private Vehicle, 2012, Mountainville

VS	ISP	advisory_data_request	=advisory_data_scope+vehicle_location_for_advisories+transit_route_number+transit_vehicle_identity	r	0.2	0.2	one request per vehicle per peak period	0	290		2.69E-03	
VS	ISP	vehicle_guidance_route_accepted	=route_identity	r	0.3	0.6	two acceptances per peak period	0	34		9.44E-04	
VS	ISP	yellow_pages_advisory_requests	=advisory_data_scope+vehicle_location_for_advisories+transit_route_number+transit_vehicle_identity+yellow_pages_dining_reservation+yellow_pages_lodging_reservation+yellow_pages_ticket_purchase	r	0.2	0.02	one yellow pages advisory per ten vehicles per peak period	0	674		6.24E-04	
VS	PayInstr	tpi_debited_driver_payment_at_vehicle	=4	r	0.2	2E-04	one vehicle per 1000 per peak period	0	50		4.63E-07	
VS	PMS	advanced_parking_lot_charges_request	=credit_identity+parking_lot_identity+parking_space_details+stored_credit+vehicle_identity	r	0.2	1E-04	one user per 1000 users per peak period	0	514		2.38E-06	
VS	PMS	parking_lot_payment_confirmation	=confirmation_flag	r	0.2	1E-04	one vehicle per 1000 per peak period	0	26		1.20E-07	
<b>TOTALS (b/s/user):</b>											<b>6.71E-02</b>	<b>4.32E-03</b>

## Traveler, 2012, Mountainville

PA Source	PA Sink	Data Flow	Contents	Dir c.	Penetration	freq	Freq. Explain	Fwd bits	Rev bits	Fwd rate (b/s/u)	Rev rate (b/s/u)
EM	PIAS	emergency_request_personal_traveler_acknowledge	=confirmation_flag	f	0.3	8E-05	one emergency per 2000 users in peak period	26	0	9.03E-08	
ISP	PIAS	transit_deviations_for_portables	=traveler_identity+list_size+TRANSIT_SEGS*(transit_vehicle_identity+transit_vehicle_achieved_time+transit_route_segment_number)	f	0.2	5E-04	one request per 20 pias per peak period	3578	0	8.28E-05	
ISP	PIAS	traveler_guidance_route	=route_identity+traveler_route+traveler_identity	f	0.3	0.015	one route per day per pias	18306	0	1.27E-02	
ISP	PIAS	traveler_personal_payment_confirmation	=advanced_tolls_confirm+advanced_fares_confirm+advanced_parking_lot_charges_confirm+credit_identity+stored_credit+traveler_identity+traveler_total_trip_cost	f	0.2	0.01	one payment per 10 pias per peak period	818	0	3.79E-04	
ISP	PIAS	traveler_personal_transaction_confirmation	=credit_identity+traveler_identity+transaction_number+yellow_pages_cost+yellow_pages_lodging_reservation_confirmation+yellow_pages_dining_reservation_confirmation+yellow_pages_ticket_purchase_confirmation	f	0.2	0.01	one confirmation per 10 pias per day	650	0	3.01E-04	
ISP	PIAS	traveler_personal_yellow_pages_data	=traveler_identity+0.01*(yellow_pages_general_information+yellow_pages_specific_information+yellow_pages_transaction_information)	f	0.2	0.1	one yellow pages response per pias per peak period	1140	0	5.28E-03	
LocData	PIAS	From_Location_Data_Source	=16	f	0.3	0.03	one in ten pias uses per peak period	146	0	2.03E-04	
PayInstr	PIAS	fpi_traveler_personal_input_credit_identity	=credit_identity	f	0.2	0.01	one transaction per 10 pias per day	178	0	8.24E-05	
PIAS	EM	emergency_request_personal_traveler_details	=date+time+traveler_personal_emergency_request	r	0.3	8E-05	one emergency per 2000 users in peak period	0	370		1.28E-06
PIAS	ISP	traffic_data_portables_request	=traffic_data_request+traveler_identity	r	0.2	0.1	one request per pias per peak period	0	250		1.16E-03
PIAS	ISP	transit_deviations_portables_request	=traveler_identity+transit_vehicle_deviation_request+transit_route_number	r	0.2	0.005	one request per 20 pias per peak period	0	250		5.79E-05

<b>Traveler, 2012, Mountainville</b>											
PIAS	ISP	traveler_personal_current_condition_request	=traveler_identity	r	0.2	0.1	one request per pias per peak period	0	210		9.72E-04
PIAS	ISP	traveler_personal_payment_information	=credit_identity+parking_space_details+ride_segments+stored_credit+toll_segments+traveler_identity	r	0.2	0.01	one payment per 10 pias per peak period	0	1130		5.23E-04
PIAS	ISP	traveler_personal_transaction_request	=yellow_pages_dining_reservation+yellow_pages_lodging_reservation+yellow_pages_ticket_purchase	r	0.2	0.01	one request per 10 pias per peak period	0	402		1.86E-04
PIAS	ISP	traveler_personal_yellow_pages_information_request	=1	r	0.2	0.1	one yellow pages request per pias per peak period	0	26		1.20E-04
PIAS	PayInstr	tpi_debited_payment_at_personal_device	=4	r	0.2	0.01	one transaction per 10 pias per day	0	50		2.31E-05
PIAS	TRMS	transit_services_portables_request	=destination+origin+traveler_identity	r	0.2	0.01	one request per 10 pias per peak period	0	466		2.16E-04
TRMS	PIAS	transit_services_for_portables	=traveler_identity+2*(transit_services_for_output)	f	0.2	0.003	one request per 20 pias per peak period	2530	0	3.87E-04	
<b>TOTALS (b/s/user):</b>									<b>1.94E-02</b>	<b>3.26E-03</b>	

## CVO-Local, 2012, Mountainville

PA Source	PA Sink	Data Flow	Contents	Dir	Penetration	freq	Freq. Explain	Fwd bits	Rev bits	Fwd rate (b/s/u)	Rev rate (b/s/u)
CVS	FMS	cf_driver_route_instructions_request	=cv_driver_number+cv_route_number	r	0.8	1.6	average fleet vehicle requests two routes per peak period	0	154		5.70E-03
CVS	FMS	cf_on_board_vehicle_data	=cv_on_board_data+cv_general_output_message+vehicle_location_for_cv	r	0.1	0.2	two times per vehicle per peak period for an average over all vehicles	0	2106		9.75E-03
CVS	FMS	cv_driver_route_request	=trip_request+route_type	r	0.8	3.2	average vehicle requests 4 routes per peak period	0	1234		9.14E-02
CVS	FMS	cv_driver_storage_request	=cv_route_number	r	0.8	0.08	one in ten vehicles per peak period	0	26		4.81E-05
CVS	FMS	cv_static_route_data	=256	r	0.8	3.2	four routes per vehicle per peak period	0	2066		1.53E-01
EM	FMS	cf_hazmat_request	=16	f	0.5	5E-05	once per 1000 vehicles per peak period	146	0	1.69E-07	
EM	VS	emergency_request_driver_acknowledge	=1	f	0.3	3E-04	one emergency per 1000 vehicles per peak period	26	0	1.81E-07	
EM	VS	emergency_request_vehicle_acknowledge	=1	f	0.3	3E-04	one emergency per 1000 vehicles per peak period	26	0	1.81E-07	
FMS	CVS	cf_driver_route_instructions	=cf_driver_route+cf_driver_load_details	f	0.8	1.6	twice per vehicle per peak period	5082	0	1.88E-01	
FMS	CVS	cf_request_on_board_vehicle_data	=2	f	0.1	0.4	four times per vehicle per peak period for an average over all vehicles	34	0	3.15E-04	
FMS	CVS	cv_driver_route_data	=cv_route_data+route_type+cv_route_number	f	0.8	3.2	average vehicle requests four routes per peak period	3042	0	2.25E-01	
FMS	CVS	cv_static_route_request	=origin+destination+departure_time+desired_arrival_time+preferences+constraints	f	0.8	3.2	average vehicle requests four routes per peak period	1226	0	9.08E-02	
FMS	EM	cf_hazmat_route_information	=cv_route_number+route	r	0.5	5E-05	once per 1000 vehicles per peak period	0	3754		4.34E-06
FMS	EM	cf_hazmat_vehicle_information	=28	r	0.5	5E-05	once per 1000 vehicles per peak period	0	242		2.80E-07

## CVO-Local, 2012, Mountainville

FMS	ImFrghD	To_Intermodal_Freight_Depot	=64	r	0.8	0.008	one in ten of vehicles interact once with an intermodal carrier	0	530		9.81E-05
FMS	ImFrghS	To_Intermodal_Freight_Shipper	=64	r	0.8	0.008	one in ten of vehicles interact once with an intermodal carrier	0	530		9.81E-05
FMS	ISP	cf_route_request	=trip_request+cv_route_number	r	0.8	0.16	twice per vehicle per peak period	0	1234		4.57E-03
FMS	ISP	cv_route_request	=trip_request+vehicle_identity	r	0.8	0.32	four times per vehicle per peak period	0	1354		1.00E-02
ImFrghD	FMS	From_Intermodal_Freight_Depot	=64	f	0.8	0.008	one in ten of vehicles interact once with an intermodal carrier	530	0		9.81E-05
ImFrghS	FMS	From_Intermodal_Freight_Shipper	=64	f	0.8	0.008	one in ten of vehicles interact once with an intermodal carrier	530	0		9.81E-05
ISP	FMS	cf_route	=cv_route_data+cv_route_number	f	0.8	0.16	twice per vehicle per peak period	3034	0		1.12E-02
ISP	FMS	cv_route	=cv_route_data+vehicle_identity	f	0.8	0.32	four times per vehicle per peak period	3154	0		2.34E-02
ISP	VS	advanced_fares_and_charges_response	=confirmation_flag+credit_identity+parking_lot_cost+stored_credit+transit_fare	f	0.2	2E-04	one user per 1000 users per peak period	234	0		1.08E-06
ISP	VS	advanced_tolls_and_fares_response	=confirmation_flag+credit_identity+stored_credit+toll_cost+transit_fare	f	0.2	2E-04	one user per 1000 users per peak period	234	0		1.08E-06
ISP	VS	advisory_data	=traffic_data_for_advisories+predicted_incidents_for_advisories+prediction_data_for_advisories+transit_services_for_advisories+transit_running_data_for_advisories	f	0.2	0.4	two sets of data per peak period	6146	0		5.69E-02
ISP	VS	yellow_pages_advisory_data	=yellow_pages_data_for_advisories+yellow_pages_cost+yellow_pages_dining_reservation_confirmation+yellow_pages_lodging_reservation_confirmation+yellow_pages_ticket_purchase_confirmation	f	0.2	0.02	one yellow pages advisory per 10 vehicles per peak period	10802	0		5.00E-03
LocData	VS	From_Location_Data_Source	=16	f	0.3	0.03	one in ten vehicles uses once per peak period	146	0		1.01E-04



## CVO-Local, 2012, Mountainville

PayInstr	VS	fpi_driver_vehicle_input_credit_identity	=credit_identity	f	0.2	2E-04	one vehicle per 1000 per peak period	178	0	8.24E-07	
VS	EM	emergency_request_driver_details	=date+driver_personal_emergency_request+time	r	0.3	3E-04	one emergency per 1000 vehicles per peak period	0	282		1.96E-06
VS	EM	emergency_request_vehicle_details	=date+time+vehicle_emergency_request	r	0.3	3E-04	one emergency per 1000 vehicles per peak period	0	3354		2.33E-05
VS	ISP	advanced_fares_and_charges_request	=0.6*(advanced_fare_details)+0.6*(advanced_parking_lot_charges)	r	0.2	2E-04	one user per 1000 users per peak period	0	632.4		2.93E-06
VS	ISP	advanced_tolls_and_fares_request	=0.6*(advanced_fare_details)+0.6*(advanced_tolls)	r	0.2	2E-04	one user per 1000 users per peak period	0	642		2.97E-06
VS	ISP	advisory_data_request	=advisory_data_scope+vehicle_location_for_advisories+transit_route_number+transit_vehicle_identity	r	0.2	0.4	two requests per vehicle per peak period	0	290		2.69E-03
VS	ISP	yellow_pages_advisory_requests	=advisory_data_scope+vehicle_location_for_advisories+transit_route_number+transit_vehicle_identity+yellow_pages_dining_reservation+yellow_pages_lodging_reservation+yellow_pages_ticket_purchase	r	0.2	0.02	one yellow pages advisory per 10 vehicles per peak period	0	674		3.12E-04
VS	PayInstr	tpi_debited_driver_payment_at_vehicle	=4	r	0.2	2E-04	one vehicle per 1000 per peak period	0	50		2.31E-07
VS	PMS	advanced_parking_lot_charges_request	=credit_identity+parking_lot_identity+parking_space_details+stored_credit+vehicle_identity	r	0.2	1E-04	one user per 1000 users per peak period	0	514		1.19E-06
VS	PMS	parking_lot_payment_confirmation	=confirmation_flag	r	0.2	1E-04	one vehicle per 1000 per peak period	0	26		6.02E-08
<b>TOTALS (b/s/user):</b>										<b>6.01E-01</b>	<b>2.78E-01</b>

## CVO-Long Haul, 2012, Mountainville

PA Source	PA Sink	Data Flow	Contents	Dir	Penetration	freq	Freq. Explain	Fwd bits	Rev bits	Fwd rate (b/s/u)	Rev rate (b/s/u)
CVAS	CVCS	cv_credentials_database_update	=cv_credentials_details+cv_credentials_status_code+cv_trip_classification_data	f	0.85	9E-05	one out of 1000 vehicles per peak period	482	0	9.48E-07	
CVAS	CVCS	cv_credentials_information_response	=cv_credentials_details+cv_credentials_status_code	f	0.85	0.009	one out of 10 vehicles	410	0	8.07E-05	
CVAS	CVCS	cv_safety_database_update	=cv_credentials_details+cv_roadside_safety_data	f	1	0.001	one out of 100 vehicles	410	0	9.49E-06	
CVAS	CVCS	cv_safety_information_response	=cv_credentials_details+cv_roadside_safety_data	f	1	0.001	one out of 100 vehicles are transmitted	410	0	9.49E-06	
CVAS	FMS	cf_clearance_enrollment_confirm	=confirmation_flag	f	0.85	0.085	once per vehicle per peak period	26	0	5.12E-05	
CVAS	FMS	cf_enrollment_information	=cv_route_number+cv_taxes_and_duties+route+route_type	f	0.85	0.043	one out of two vehicles require info. per peak period	3818	0	3.76E-03	
CVAS	FMS	cf_enrollment_payment_confirmation	=cv_route_number+cv_account_number+cv_amount_billed	f	0.85	0.085	once per vehicle per peak period	170	0	3.34E-04	
CVAS	FMS	cv_enrollment_information	=cv_route_number+cv_taxes_and_duties+route+route_type	f	0.85	0.043	one out of two vehicles require info. per peak period	3818	0	3.76E-03	
CVAS	FMS	cv_enrollment_payment_confirmation	=cv_account_number+cv_amount_billed+cv_driver_credit_identity+cv_route_number	f	0.85	0.085	once per vehicle per peak period	346	0	6.81E-04	
CVCS	CVAS	cv_credentials_information_request	=cv_credentials_details+cv_credentials_request_type+cv_credentials_request_identity+cv_roadside_facility_identity	r	0.85	0.009	request info on one in ten vehicles	0	554		1.09E-04
CVCS	CVAS	cv_roadside_daily_log	=cv_roadside_facility_identity+date++cv_archived_safety_data+cv_archived_inspection_data+cv_screening_record	r	0.85	9E-04	one report per 100 vehicles per peak period	0	3362		6.62E-05
CVCS	CVAS	cv_safety_information_request	=cv_credentials_details+cv_safety_information_request_identity+cv_safety_information_request_type+cv_roadside_facility_identity	r	1	0.01	request info on one in ten vehicles	0	554		1.28E-04
CVCS	CVAS	cv_update_safety_problems_list	=cv_credentials_details+cv_roadside_facility_identity+cv_roadside_safety_data	r	1	0.001	one out of 100 vehicles are on the list per peak period	0	538		1.25E-05

## CVO-Long Haul, 2012, Mountainville

CVS	FMS	cf_driver_route_instructions_request	=cv_driver_number+cv_route_number	r	0.8	0.8	average fleet vehicle requests one route per peak period	0	154		2.85E-03
CVS	FMS	cf_on_board_vehicle_data	=cv_on_board_data+cv_general_output_message+vehicle_location_for_cv	r	0.1	0.2	two times per vehicle per peak period for an average over all vehicles	0	2106		9.75E-03
CVS	FMS	cv_driver_enrollment_payment_request	=cv_account_number+cv_driver_credit_identity+cv_route_number	r	0.85	0.85	once per vehicle per peak period	0	330		6.49E-03
CVS	FMS	cv_driver_enrollment_request	=cv_cargo_class+cv_route_number+cv_vehicle_class+cv_weight_class	r	0.85	0.85	once per vehicle per peak period	0	98		1.93E-03
CVS	FMS	cv_driver_route_request	=trip_request+route_type	r	0.8	1.6	average vehicle requests 2 routes per peak period	0	1234		4.57E-02
CVS	FMS	cv_driver_storage_request	=cv_route_number	r	0.8	0.08	one in ten vehicles per peak period	0	26		4.81E-05
CVS	FMS	cv_static_route_data	=256	r	0.8	1.6	two routes per vehicle per peak period	0	2066		7.65E-02
EM	FMS	cf_hazmat_request	=16	f	0.5	5E-05	once per 1000 vehicles per peak period	146	0	1.69E-07	
EM	VS	emergency_request_driver_acknowledge	=1	f	0.3	3E-04	one emergency per 1000 vehicles per peak period	26	0	1.81E-07	
EM	VS	emergency_request_vehicle_acknowledge	=1	f	0.3	3E-04	one emergency per 1000 vehicles per peak period	26	0	1.81E-07	
FMS	CVAS	cf_enroll_clearance_data	=cv_credentials_details	r	0.85	0.085	once per vehicle per peak period	0	402		7.91E-04
FMS	CVAS	cf_enrollment_payment_request	=cf_manager_credit_identity+cv_account_number+cv_route_number+1.5*(cv_taxes_and_duties)	r	0.85	0.085	once per vehicle per peak period	0	414		8.15E-04
FMS	CVAS	cf_enrollment_request	=cv_route_data+cv_credentials_details+cv_route_number+cv_trip_classification_data+route_type	r	0.85	0.085	once per vehicle per peak period	0	3498		6.88E-03
FMS	CVAS	cv_enrollment_payment_request	=cv_account_number+cv_driver_credit_identity+cv_route_number+1.5*(cv_taxes_and_duties)	r	0.85	0.085	once per vehicle per peak period	0	414		8.15E-04
FMS	CVAS	cv_enrollment_request	=cv_route_data+cv_credentials_details+cv_trip_classification_data+cv_route_number+route_type	r	0.85	0.085	once per vehicle per peak period	0	3498		6.88E-03

## CVO-Long Haul, 2012, Mountainville

FMS	CVS	cf_driver_route_instructions	=cf_driver_route+cf_driver_load_details	f	0.8	0.8	once per vehicle per peak period	5082	0	9.41E-02	
FMS	CVS	cf_request_on_board_vehicle_data	=2	f	0.1	0.2	two times per vehicle per peak period for an average over all vehicles	34	0	1.57E-04	
FMS	CVS	cv_driver_enrollment_information	=cv_route_number+cv_taxes_and_duties	f	0.85	0.425	one out of two vehicles require info. per peak period	82	0	8.07E-04	
FMS	CVS	cv_driver_enrollment_payment_confirmation	=cv_account_number+cv_amount_billed+cv_driver_credit_identity+cv_route_number	f	0.85	0.85	once per vehicle per peak period	346	0	6.81E-03	
FMS	CVS	cv_driver_route_data	=cv_route_data+route_type+cv_route_number	f	0.8	1.6	average vehicle requests two routes per peak period	3042	0	1.13E-01	
FMS	CVS	cv_static_route_request	=origin+destination+departure_time+desired_arrival_time+preferences+constraints	f	0.8	1.6	average vehicle requests two routes per peak period	1226	0	4.54E-02	
FMS	EM	cf_hazmat_route_information	=cv_route_number+route	r	0.5	5E-05	once per 1000 vehicles per peak period	0	3754		4.34E-06
FMS	EM	cf_hazmat_vehicle_information	=28	r	0.5	5E-05	once per 1000 vehicles per peak period	0	242		2.80E-07
FMS	ImFrghD	To_Intermodal_Freight_Depot	=64	r	0.8	0.008	one in ten vehicles interacts once with an intermodal carrier	0	530		9.81E-05
FMS	ImFrghS	To_Intermodal_Freight_Shipper	=64	r	0.8	0.008	one in ten vehicles interacts once with an intermodal carrier	0	530		9.81E-05
FMS	ISP	cf_route_request	=trip_request+cv_route_number	r	0.8	0.08	once per vehicle per peak period	0	1234		2.29E-03
FMS	ISP	cv_route_request	=trip_request+vehicle_identity	r	0.8	0.16	twice per vehicle per peak period	0	1354		5.01E-03
FMS	PayInstr	tpi_debited_commercial_manager_payment	=4	r	0.85	0.085	once per enrollment	0	50		9.84E-05
ImFrghD	FMS	From_Intermodal_Freight_Depot	=64	f	0.8	0.008	one in ten vehicles interacts once with an intermodal carrier	530	0	9.81E-05	

## CVO-Long Haul, 2012, Mountainville

ImFrghS	FMS	From_Intermodal_Freight_Shipper	=64	f	0.8	0.008	one in ten vehicles interacts once with an intermodal carrier	530	0	9.81E-05	
ISP	FMS	cf_route	=cv_route_data+cv_route_number	f	0.8	0.08	once per vehicle per peak period	3034	0	5.62E-03	
ISP	FMS	cv_route	=cv_route_data+vehicle_identity	f	0.8	0.16	twice per vehicle per peak period	3154	0	1.17E-02	
ISP	VS	advanced_fares_and_charges_response	=confirmation_flag+credit_identity+parking_lot_cost+stored_credit+transit_fare	f	0.2	2E-04	one user per 1000 users per peak period	234	0	1.08E-06	
ISP	VS	advanced_tolls_and_fares_response	=confirmation_flag+credit_identity+stored_credit+toll_cost+transit_fare	f	0.2	2E-04	one user per 1000 users per peak period	234	0	1.08E-06	
ISP	VS	advisory_data	=traffic_data_for_advisories+predicted_incidents_for_advisories+prediction_data_for_advisories+transit_services_for_advisories+transit_running_data_for_advisories	f	0.2	0.2	one set of data per peak period	6146	0	2.85E-02	
ISP	VS	yellow_pages_advisory_data	=yellow_pages_data_for_advisories+yellow_pages_cost+yellow_pages_dining_reservation_confirmation+yellow_pages_lodging_reservation_confirmation+yellow_pages_ticket_purchase_confirmation	f	0.2	0.02	one yellow pages advisory per 10 vehicles per peak period	10802	0	5.00E-03	
LocData	VS	From_Location_Data_Source	=16	f	0.3	0.03	one in ten vehicles uses once per peak period	146	0	1.01E-04	
PayInstr	FMS	fpi_commercial_manager_input_credit_identity	=12	f	0.85	0.085	once per enrollment = once per cv per peak period	114	0	2.24E-04	
PayInstr	VS	fpi_driver_vehicle_input_credit_identity	=credit_identity	f	0.2	2E-04	one vehicle per 1000 per peak period	178	0	8.24E-07	
VS	EM	emergency_request_driver_details	=date+driver_personal_emergency_request+time	r	0.3	3E-04	one emergency per 1000 vehicles per peak period	0	282		1.96E-06
VS	EM	emergency_request_vehicle_details	=date+time+vehicle_emergency_request	r	0.3	3E-04	one emergency per 1000 vehicles per peak period	0	3354		2.33E-05
VS	ISP	advanced_fares_and_charges_request	=0.6*(advanced_fare_details)+0.6*(advanced_parking_lot_charges)	r	0.2	2E-04	one user per 1000 users per peak period	0	632.4		2.93E-06
VS	ISP	advanced_tolls_and_fares_request	=0.6*(advanced_fare_details)+0.6*(advanced_tolls)	r	0.2	2E-04	one user per 1000 users per peak period	0	642		2.97E-06

## CVO-Long Haul, 2012, Mountainville

VS	ISP	advisory_data_request	=advisory_data_scope+vehicle_location_for_advisories+transit_route_number+transit_vehicle_identity	r	0.2	0.4	two requests per vehicle per peak period	0	290		2.69E-03
VS	ISP	vehicle_guidance_route_accepted	=route_identity	r	0.3	0.6	two acceptances per peak period	0	34		4.72E-04
VS	ISP	yellow_pages_advisory_requests	=advisory_data_scope+vehicle_location_for_advisories+transit_route_number+transit_vehicle_identity+yellow_pages_dining_reservation+yellow_pages_lodging_reservation+yellow_pages_ticket_purchase	r	0.2	0.02	one yellow pages advisory per 10 vehicles per peak period	0	674		3.12E-04
VS	PayInstr	tpi_debited_driver_payment_at_vehicle	=4	r	0.2	2E-04	one vehicle per 1000 per peak period	0	50		2.31E-07
VS	PMS	advanced_parking_lot_charges_request	=credit_identity+parking_lot_identity+parking_space_details+stored_credit+vehicle_identity	r	0.2	1E-04	one user per 1000 users per peak period	0	514		1.19E-06
VS	PMS	parking_lot_payment_confirmation	=confirmation_flag	r	0.2	1E-04	one vehicle per 1000 per peak period	0	26		6.02E-08
<b>TOTALS (b/s/user):</b>									<b>3.20E-01</b>	<b>1.71E-01</b>	

## Transit, 2012, Mountainville

PA Source	PA Sink	Data Flow	Contents	Dire c.	Pene tration	freq	Freq. Explain	Fwd bits	Rev bits	Fwd rate (b/s/u)	Rev rate (b/s/u)
ISP	RTS	advanced_tolls_and_charges_roadside_confirm	=advanced_charges_confirm+advanced_tolls_confirm+confirmation_flag	f	0.2	6E-04	one use per 1000 transit users per peak period, or 0.032/transit vehicle	426	0	5.83E-06	
ISP	RTS	traveler_payment_confirmation	=advanced_tolls_confirm+advanced_fares_confirm+advanced_parking_lot_charges_confirm+credit_identity+kiosk_identity+stored_credit+traveler_total_trip_cost	f	0.2	6E-04	one use per 1000 transit users per peak period, or 0.032/transit vehicle	666	0	9.11E-06	
ISP	RTS	traveler_transaction_confirmation	=credit_identity+kiosk_identity+transaction_number+yellow_pages_cost+yellow_pages_lodging_reservation_confirmation+yellow_pages_dining_reservation_confirmation+yellow_pages_ticket_purchase_confirmation	f	0.2	6E-04	one use per 1000 transit users per peak period, or 0.032/transit vehicle	498	0	6.81E-06	

## Transit, 2012, Mountainville

ISP	RTS	traveler_yellow_pages_data	=kiosk_identity+0.01*(yellow_pages_general_information+yellow_pages_specific_information+yellow_pages_transaction_information)	f	0.2	6E-04	one use per 1000 transit users per peak period, or 0.032/transit vehicle	987.7	0	1.35E-05	
PayInstr	RTS	fpi_confirm_fare_payment_at_roadside	=confirmation_flag	f	0.2	0.128	one in five transit users = 6.4 per transit vehicle per peak period	26	0	7.11E-05	
PayInstr	RTS	fpi_transit_roadside_tag_data	=credit_identity	f	0.2	6E-04	one data set for 1000 users = 0.032 uses per transit vehicle per peak period	178	0	2.43E-06	
PayInstr	RTS	fpi_transit_user_roadside_input_credit_identity	=credit_identity	f	0.2	6E-04	one data set for 1000 users = 0.032 uses per transit vehicle per peak period	178	0	2.43E-06	
PayInstr	RTS	fpi_traveler_roadside_input_credit_identity	=credit_identity	f	0.2	6E-04	one data set for 1000 users = 0.032 uses per transit vehicle per peak period	178	0	2.43E-06	
PayInstr	TRVS	fpi_confirm_fare_payment_on_transit_vehicle	=confirmation_flag	f	1	32	average of one use per transit user per peak period = 32 per transit vehicle	26	0	1.78E-02	
PayInstr	TRVS	fpi_transit_vehicle_tag_data	=credit_identity	f	1	0.032	one data set for 1000 users = 0.032 uses per transit vehicle per peak period	178	0	1.22E-04	
RTS	EM	emergency_request_kiosk_traveler_details	=date+time+traveler_personal_emergency_request	r	1	0.003	one emergency per 1000 transit users per peak period, or 0.032/transit vehicle	0	370		2.53E-05
RTS	ISP	advanced_tolls_and_charges_roadside_request	=0.6*(advanced_charges)+0.6*(advanced_tolls)	r	0.2	6E-04	one use per 1000 transit users per peak period, or 0.032/transit vehicle	0	738		1.01E-05
RTS	ISP	traffic_data_kiosk_request	=kiosk_identity+traffic_data_request	r	0.2	0.64	average of one use per transit user per peak period = 32 per transit vehicle	0	98		1.34E-03

# Transit, 2012, Mountainville

RTS	ISP	transit_deviation_kiosk_request	=kiosk_identity+transit_vehicle_deviation_request	r	0.2	0.128	one in five transit users = 6.4 per transit vehicle per peak period	0	66		1.81E-04
RTS	ISP	traveler_current_condition_request	=kiosk_identity	r	0.2	0.64	average of one use per transit user per peak period = 32 per transit vehicle	0	58		7.93E-04
RTS	ISP	traveler_payment_information	=credit_identity+kiosk_identity+parking_space_details+ride_segments+stored_credit+toll_segments	r	0.2	6E-04	one use per 1000 transit users per peak period, or 0.032/transit vehicle	0	978		1.34E-05
RTS	ISP	traveler_transaction_request	=yellow_pages_dining_reservation+yellow_pages_lodging_reservation+yellow_pages_ticket_purchase	r	0.2	6E-04	one use per 1000 transit users per peak period, or 0.032/transit vehicle	0	402		5.50E-06
RTS	ISP	traveler_trip_confirmation	=paratransit_service_confirmation+traveler_identity+traveler_rideshare_confirmation	r	0.2	6E-04	one use per 1000 transit users per peak period, or 0.032/transit vehicle	0	858		1.17E-05
RTS	ISP	traveler_trip_request	=trip_request+traveler_identity+traveler_rideshare_request	r	0.2	6E-04	one use per 1000 transit users per peak period, or 0.032/transit vehicle	0	1434		1.96E-05
RTS	ISP	traveler_yellow_pages_information_request	=1	r	0.2	6E-04	one use per 1000 transit users per peak period, or 0.032/transit vehicle	0	26		3.56E-07
RTS	PayInstr	tpi_debited_fare_payment_at_roadside	=4	r	0.2	0.128	one in five transit users = 6.4 per transit vehicle per peak period	0	50		1.37E-04
RTS	PayInstr	tpi_debited_transit_user_payment_at_roadside	=4	r	0.2	0.064	one in ten transit users = 3.2 per transit vehicle per peak period	0	50		6.84E-05
RTS	PayInstr	tpi_debited_traveler_payment_at_roadside	=4	r	0.2	6E-04	one data set for 1000 users = 0.032 uses per transit vehicle per peak period	0	50		6.84E-07
RTS	PayInstr	tpi_request_fare_payment_at_roadside	=2	r	0.2	6E-04	one data set for 1000 users = 0.032 uses per transit vehicle per peak period	0	34		4.65E-07



## Transit, 2012, Mountainville

TRMS	TRVS	approved_corrective_plan	=transit_route_corrections+transit_changes_in_stops+transit_changes_in_speed	f	1	0.1	one corrective message per ten vehicles per peak period	8210	0	1.75E-02
TRMS	TRVS	confirm_vehicle_fare_payment	=confirmation_flag	f	1	32	average of one use per transit user per peak period = 32 per transit vehicle	26	0	1.78E-02
TRMS	TRVS	other_services_vehicle_response	=traveler_identity+credit_identity+other_services_data	f	0.2	0.006	one data set for 1000 users = 0.032 uses per transit vehicle per peak period	2418	0	3.31E-04
TRMS	TRVS	paratransit_transit_driver_instructions	=128	f	1	13	dispatch message every 15 min. during peak period=48/4(ratio of paratr/tr veh)	1042	0	2.89E-01
TRMS	TRVS	request_transit_user_image	=8	f	1	0.032	one image for 1000 users = 0.032 uses per transit vehicle per peak period	82	0	5.61E-05
TRMS	TRVS	transit_operator_request_acknowledge	=2	f	1	0.032	one data set for 1000 users = 0.032 uses per transit vehicle per peak period	34	0	2.32E-05
TRMS	TRVS	transit_services_for_corrections	=list_size+1*(2/NUM_TRANSIT_ROUTES)*(transit_services)	f	1	13	one correction per hour during the peak period	17260	0	4.79E+00
TRMS	TRVS	transit_services_for_eta	=transit_route_number+transit_route_segment_list+transit_route_stop_list	f	1	52	update every 15 minutes during the peak period	7786	0	8.65E+00
TRMS	TRVS	transit_services_for_vehicle_fares	=transit_route_fare_data	f	1	1	update daily during peak period	16826	0	3.60E-01
TRMS	TRVS	transit_vehicle_advanced_payment_response	=advanced_charges_confirm+advanced_tolls_confirm+confirmation_flag+transit_vehicle_identity	f	1	0.032	one data set for 1000 users = 0.032 uses per transit vehicle per peak period	554	0	3.79E-04
TRMS	TRVS	transit_vehicle_fare_data	=transit_fares	f	1	1	updated once per peak period per transit vehicle	922	0	1.97E-02
TRMS	TRVS	transit_vehicle_fare_payment_debited	=confirmation_flag	f	1	32	average of one use per transit user per peak period = 32 per transit vehicle	26	0	1.78E-02

# Transit, 2012, Mountainville

TRMS	TRVS	transit_vehicle_fare_payment_request	=transit_fare	f	1	32	average of one use per transit user per peak period = 32 per transit vehicle	34	0	2.32E-02	
TRVS	PayInstr	tpi_debited_payment_on_transit_vehicle	=4	f	1	32	average of one use per transit user per peak period = 32 per transit vehicle	50	0	3.42E-02	
TRVS	PayInstr	tpi_request_fare_payment_on_transit_vehicle	=2	f	1	32	average of one use per transit user per peak period = 32 per transit vehicle	34	0	2.32E-02	
TRVS	TRMS	other_services_vehicle_request	=traveler_identity+credit_identity+other_services_data	r	0.2	0.006	one data set for 1000 users = 0.032 uses per transit vehicle per peak period	0	2418		3.31E-04
TRVS	TRMS	paratransit_transit_vehicle_availability	=1	r	1	13	avail. message every 15 min. during peak period=48/4(ratio of paratr/tr veh)	0	26		7.22E-03
TRVS	TRMS	request_vehicle_fare_payment	=credit_identity+transit_fare+transit_route_number+transit_route_segment_number+transit_route_use_time+transit_user_category+traveler_identity	r	1	32	average of one use per peak period per transit user = 32 per transit vehicle	0	466		3.19E-01
TRVS	TRMS	transit_conditions_request	=2	r	1	0.1	one corrective message per ten vehicles per peak period	0	34		7.26E-05
TRVS	TRMS	transit_emergency_details	=transit_driver_emergency_request+transit_user_emergency_request+transit_vehicle_location	r	1	0.003	emergency for one in 10000 transit users=0.0032 per transit vehicle per peak	0	282		1.93E-05
TRVS	TRMS	transit_emergency_information	=transit_driver_emergency_request+transit_user_emergency_request+transit_vehicle_location	r	1	0.003	emergency for one in 10000 transit users=0.0032 per transit vehicle per peak	0	282		1.93E-05
TRVS	TRMS	transit_operator_emergency_request	=128	r	1	0.003	emergency for one in 10000 transit users=0.0032 per transit vehicle per peak	0	1042		7.12E-05

## Transit, 2012, Mountainville

TRVS	TRMS	transit_services_for_eta_request	=transit_vehicle_identity+transit_route_number+transit_route_schedule_number	r	1	3.2	average of one use per 10 transit users per peak period=3.2 per transit vehicle	0	186		1.27E-02
TRVS	TRMS	transit_user_vehicle_image	=JPEG*(ftu_transit_user_vehicle_image)	r	1	0.011	20 images per metro area per peak period=20/1788 transit vehicles	0	73746		1.73E-02
TRVS	TRMS	transit_vehicle_advanced_payment_request	=advanced_charges+advanced_tolls+transit_vehicle_location	r	0.2	0.006	one data set for 1000 users = 0.032 uses per transit vehicle per peak period	0	1450		1.98E-04
TRVS	TRMS	transit_vehicle_arrival_conditions	=128	r	1	13	updated every 60 minutes during the peak period	0	1042		2.89E-01
TRVS	TRMS	transit_vehicle_collected_trip_data	=transit_vehicle_passenger_loading+transit_vehicle_running_times	r	1	13	every hour for each transit vehicle per peak period	0	1826		5.07E-01
TRVS	TRMS	transit_vehicle_deviations_from_schedule	=32	r	1	52	update every 15 minutes during the peak period	0	274		3.04E-01
TRVS	TRMS	transit_vehicle_eta	=transit_vehicle_identity+transit_vehicle_time+transit_route_number	r	1	156	updated every 5 minutes during the peak period	0	234		7.80E-01
TRVS	TRMS	transit_vehicle_fare_payment_confirmation	=confirmation_flag	r	1	32	average of one use per transit user per peak period = 32 per transit vehicle	0	26		1.78E-02
TRVS	TRMS	transit_vehicle_location	=transit_vehicle_identity+transit_vehicle_location_data	r	1	52	updated every 15 minutes during the peak period	0	250		2.78E-01
TRVS	TRMS	transit_vehicle_location_for_deviation	=transit_vehicle_identity+transit_vehicle_location_data	r	1	52	updated every 15 minutes during the peak period	0	250		2.78E-01
TRVS	TRMS	transit_vehicle_location_for_store	=transit_vehicle_identity+transit_vehicle_location_data	r	1	13	updated every 60 minutes during the peak period	0	250		6.94E-02
TRVS	TRMS	transit_vehicle_passenger_data	=transit_passenger_numbers+transit_route_number+transit_route_segment_number+transit_route_use_time+transit_user_category+transit_vehicle_identity	r	1	52	update every 15 minutes during the peak period	0	242		2.69E-01
TRVS	TRMS	transit_vehicle_schedule_deviation	=32	r	1	52	updated every 15 minutes during the peak period	0	274		3.04E-01
<b>TOTALS (b/s/user):</b>									<b>1.43E+01</b>	<b>3.46E+00</b>	

## Emergency Management, 2012, Mountainville

PA Source	PA Sink	Data Flow	Contents	Dir c.	Pen e tra ti on	freq	Freq. Explain	Fwd bits	Rev bits	Fwd rate (b/s/u)	Rev rate (b/s/u)
EM	EVS	emergency_vehicle_driver_outputs	=128	f	1	13	average one driver output per vehicle per hour during the peak period	1042	0	2.89E-01	
EVS	EM	emergency_driver_dispatch_acknowledge	=1	r	1	26	average one dispatch acknowledge per vehicle per 1/2 hour during the peak period	0	26		1.44E-02
EVS	EM	emergency_driver_statuses_update	=16	r	1	26	average one status update per vehicle per 1/2 hour during the peak period	0	146		8.11E-02
EVS	EM	emergency_vehicle_driver_inputs	=64	r	1	13	average one driver input per vehicle per hour during the peak period	0	530		1.47E-01
<b>TOTALS (b/s/user):</b>										<b>2.89E-01</b>	<b>2.43E-01</b>

## **APPENDIX G USE OF BEACONS FOR WIDE AREA DELIVERY/COLLECTION OF ITS INFORMATION**

### **G.1 Introduction**

In the ITS architecture, certain ITS interconnections are handled by means of wide area wireless communication systems such as cellular, while other services are handled by short range wireless links such as dedicated short range communications (DSRC) systems or beacons. It is important to choose the communications technology appropriate for each application. It is also worthwhile to observe that ITS has a number of new applications for each technology that will expand the use of existing infrastructures. Significant attention has been paid to the wide area technology elsewhere in this document. This section focuses more on the dedicated short range communications. The broad collection of messages specific to this interface is summarized in table G5.1.

The first type of interconnections, wide area wireless communication systems, supports several service groupings which include:

- traveler and driver information (e.g., routes, yellow pages information, emergency services)
- commercial vehicle operation – local and long haul (e.g., routes, dispatch, preclearance, yellow pages, emergency services, vehicle and cargo tracking)
- emergency vehicle management (e.g., dispatch, routes, status reporting)

The second type of interconnections, short range wireless links, support services that include:

- public transportation management (e.g., fixed route and paratransit management, emergency services, fare and passenger load management)
- toll collection
- roadside safety inspection (e.g., roadside check and safety check)
- in-vehicle signing (e.g., fixed signage beacons, incident warning beacons)

Message structure, traffic loading, and performance have been analyzed elsewhere in this document for the first type of interconnections under the proposed cell-based architecture. However, the partition of user services between wide-area and short-range wireless communication is not uniquely determined by (technical) system requirements.

In the communications analysis, messages are allowed to flow over the wide area (u1t) interface and the dedicated short range (u2) interface. A determination of the fraction that may flow over each interface was also made. The assignments are detailed in Section 4.5 of this document.

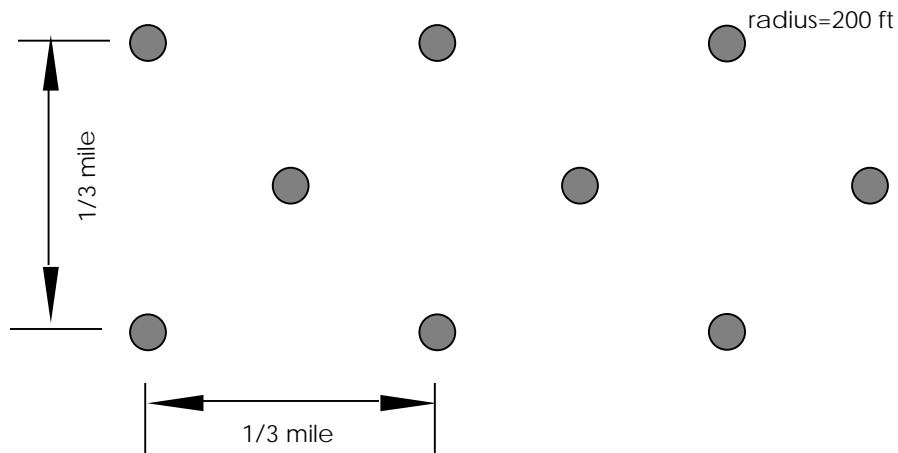
Table 4.5-1 lists the messages and the interface(s) that each is allowed to flow over. This table was primarily developed in order to model the u1t interface loads, and therefore was designed for the worst case analysis for that interface. This means that the ratio of u1t to u2 data loads was kept high, and u1t data loads were maximized by assuming that the use of the u2 interface does not, in many cases, reduce the u1t data load. This was done in order to model the worst case situation where no beacons are deployed.

The purpose of this section is to examine, primarily from technical and feasibility standpoints, alternative architectures in which some or all of the services in the first category are provided by short-range wireless communication between vehicles and roadside beacons, i.e., wide area coverage by means of roadside beacons. The specific beacon system considered here just as an example is Hughes' DSRC system.

Three technical issues will be examined quantitatively, based on traffic loading analyses which have already been performed. These are: 1) compatibility of message formats with Hughes' signaling format used here as a working example; 2) the impact of DSRC data traffic on the wireline network; and 3) most importantly, the crucial issue of coverage and the related problems of delay and complexity. Conclusions will then be drawn, from a technical perspective, regarding the utilization of short-range communication systems (beacons) in the ITS architecture. This will be followed by an analysis that touches upon the economic considerations of wide area deployment of dedicated beacon systems.

## G.2 Candidate Beacon Deployment

All beacons in the metropolitan area are assumed to use the same frequency, and beacon placement is constrained by the need to eliminate interference. In the DSRC system, receiver sensitivity is set to limit the effective range to about 200 feet. For acceptable interference levels, the minimum separation between beacons in the absence of obstructions is about 1/3 mile. This leads to the deployment shown below using cross-hatched circles. In an urban or suburban setting, however, the obstruction caused by buildings located on a rectangular street grid allows placement of additional beacons without interference. Typically the number of beacons can be doubled by locating the additional beacons (shown as dotted circles) equidistant from the original ones. We therefore postulate the idealized full deployment of Figure G.2-1.



**Figure G.2-1 Full Deployment of a Beacon System**

In this deployment, there are eighteen beacons per square mile. Since the Urbansville region covers 800 square miles, the postulated deployment would require approximately 14,400 beacons. The postulated full deployment of DSRC would greatly increase the number of devices which must be installed along roadways and connected via wired communication networks relative to a cellular wide area solution, and would thus increase the initial costs associated with communication infrastructure deployment.

Another key aspect of the indicated deployment is that the fraction of the total area actually within communication range of a beacon is just  $18 * \pi(200)^2 / 5280^2 = 0.081$  (8.1%). However, given that the vehicles move essentially on surface streets and highways, it is more meaningful to compute the percentage of “linear” coverage, i.e., the fraction of the roadway length covered by the beacons. The fraction is slightly higher at  $200 / (5280/3) = 0.114$  (11.4%). This immediately points out to the fact that only a small percentage of the vehicles will be within range of such a fully deployed system.

This possible coverage could be increased if frequency reuse were implemented, since beacons operating at different frequencies could be interspersed among those shown above. Such a system would then be no different from a full fledged micro-cellular system-- and if implemented on a wide scale as in the case of cellular telephone systems, would be prohibitively expensive for any dedicated set of users. Such a hypothetical situation, however, would defeat the essence of DSRC, which is based on site specific information exchange. Thus, it will not be considered.

### **G.3 Message Compatibility with DSRC**

Again we consider here the open system specification proposed by Hughes as an example of a DSRC system capabilities. The Hughes system uses TDMA with a reservation slotted-ALOHA access protocol to resolve collisions that result from multiple vehicles responding to the trigger of the reader. The TDMA protocol has a basic frame length of 9.58 ms (including guard and dead times) during which the reader and transponders communicate. The frame consists of three segments. The first is the segment where the reader sends a control message to activate the transponders and/or give them instructions. The second segment is the data message segment containing four slots each of which can be used for either forward or reverse transmission of a data packet under control of the reader. The size of these packets is 512 bits. The third segment is the one in which transponders respond to the reader's trigger with their respective ID's.

The message lengths which have been defined in the ITS architecture to be sent over the u2 interface for various wireless ITS services are generally less than 500 bits. (See Table G.5-1 for a listing of the messages.) Hence, the majority of ITS messages will be compatible with a single 512 bit slot in the DSRC TDMA format. In some cases, messages may include larger amounts of data that will significantly increase their length. However, these messages can be accommodated either by multiple slots within a frame or multiple slots in successive frames.

### **G.4 Impact of ITS Data on Beacon Capacity**

The effective user data rate of a beacon (on the order of 200 kbps) is much greater than that of a mobile wide area wireless channel (e.g., a CDPD channel with a 19.2 kbps channel rate). In addition, a beacon will serve fewer vehicles than a cellular sector. Therefore, data throughput of a DSRC is adequate to support ITS wireless traffic from vehicles within its limited range (100 to 200 feet).

## **G.5 Impact of DSRC Traffic on Wireline Network**

If wide area wireless communication is based on beacons rather than cell-based techniques, additional communications loading will occur on the wireline network connecting beacons, hubs and TMCs. In a cell-based architecture, wide area mobile communications are provided by wireless carriers, so they do not contribute to this wireline traffic. If cellular communications were replaced by widely deployed beacons, some of this wireless traffic would also have to pass through the ITS wireline network.

Many beacons may be placed along highway rights of way and then be able to utilize any private fiber network placed along that path to provide wireline communications with their controller.

The larger fraction of the total beacon population that is not along a fiber route will need to be connected to the beacon controller through additional wireline links. These will be assumed to be leased digital lines and will not impact the performance of any existing wireline network..



**Table G.5-1 ITS Wireless Messages for the u2 Interface**

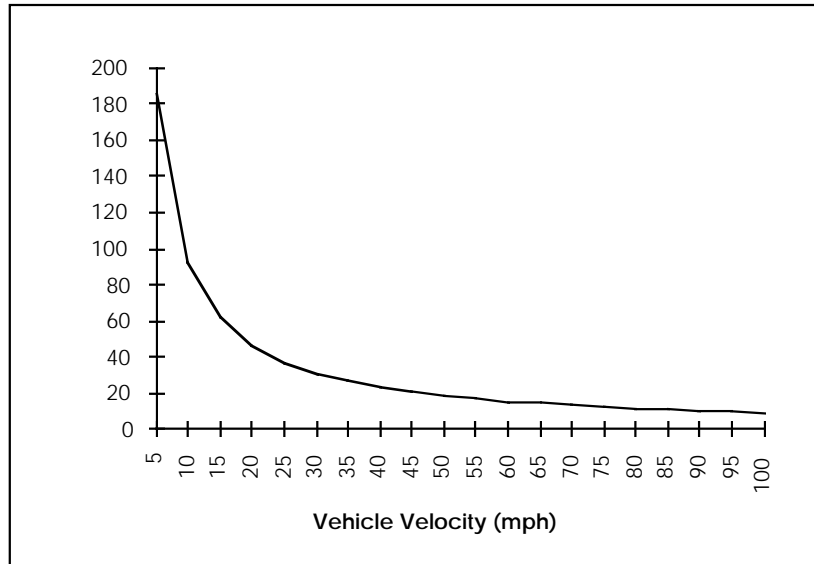
PA Source	PA Sink	Logical Data Flow	Size (Bytes)
Basic Vehicle	PMS	fbv vehicle characteristics	6
Basic Vehicle	RS	fbv vehicle characteristics	6
Basic Vehicle	TCS	fbv vehicle characteristics	6
Commercial Vehicle	CVCS	fcv vehicle characteristics	6
CVCS	Commercial Vehicle Driver	tcvd clearance pull in output	64
CVCS	Commercial Vehicle Driver	tcvd general pull in output	64
CVCS	Commercial Vehicle Driver	tcvd safety pull in output	64
CVCS	Commercial Vehicle Driver	tcvd inspection results	32
CVCS	CVS	cv inspection data output	1024
CVCS	CVS	cv request on board data	32
CVS	CVCS	cv on board data	200
CVS	CVCS	cv electronic clearance data	48
EVS	RS	emergency vehicle preemptions	8
PMS	Driver	td parking lot payment confirmed	2
PMS	Driver	td parking lot payment invalid	2
PMS	VS	parking lot payment debited	1
PMS	VS	parking lot payment request	2
PMS	VS	advanced parking lot charges confirm	18
Potential Obstacles	VS	From Potential Obstacles	16
Roadway	VS	From Roadway	16
Roadway	VS	From Roadway	16
RS	Driver	td lane use indication	4
RS	Driver	td ramp state indication	4
RS	Driver	td signal indication	4
RS	Driver	td vms indication	8
RS	VS	vehicle signage data	20
RS	VS	ahs check response	513
TCS	Driver	td toll payment confirmed	2
TCS	Driver	td toll payment invalid	2
TCS	VS	toll payment debited	1
TCS	VS	toll payment request	2
TRMS	Transit Driver	ttd route assignments	64
TRMS	TRVS	transit operator request acknowledge	2
TRMS	TRVS	approved corrective plan	1024
TRMS	TRVS	transit vehicle conditions	2908
TRMS	TRVS	paratransit transit driver instructions	128
TRMS	TRVS	transit services for corrections	10240000
TRMS	TRVS	transit services for eta	10240000
TRMS	TRVS	transit vehicle advanced payment response	53
TRMS	TRVS	transit vehicle fare payment debited	1
TRMS	TRVS	transit vehicle fare payment request	2
TRMS	TRVS	transit vehicle fare data	113
TRMS	TRVS	request transit user image	8
TRMS	TRVS	other services vehicle response	293
TRMS	TRVS	transit services for vehicle fares	10240000
TRMS	TRVS	confirm vehicle fare payment	1
TRVS	Payment Instrument	tpi debited payment on transit vehicle	4
TRVS	Payment Instrument	tpi request fare payment on transit vehicle	2
TRVS	RS	transit roadway preemptions	16
TRVS	RS	transit ramp preemptions	16
TRVS	TRMS	transit emergency details	36
TRVS	TRMS	transit operator emergency request	256
TRVS	TRMS	transit user vehicle image	1024000
TRVS	TRMS	fare collection vehicle violation information	1024046
TRVS	TRMS	request vehicle fare payment	49

**Table G.5-1 ITS Wireless Messages for the u2 Interface**

PA Source	PA Sink	Logical Data Flow	Size (Bytes)
TRVS	TRMS	other services vehicle request	293
TRVS	TRMS	transit vehicle passenger data	28
TRVS	TRMS	paratransit transit vehicle availability	1
TRVS	TRMS	transit vehicle fare payment confirmation	1
TRVS	TRMS	transit vehicle advanced payment request	283
TRVS	TRMS	transit vehicle location for deviation	32
TRVS	TRMS	transit vehicle location	32
TRVS	TRMS	transit vehicle arrival conditions	128
TRVS	TRMS	transit vehicle schedule deviation	32
TRVS	TRMS	transit vehicle eta	27
TRVS	TRMS	transit vehicle deviations from schedule	32
TRVS	TRMS	transit conditions request	2
TRVS	TRMS	transit vehicle collected data	0
TRVS	TRMS	transit emergency information	36
TRVS	TRMS	transit vehicle location for store	32
Vehicle Characteristics	PMS	From Vehicle Characteristics	1000000
Vehicle Characteristics	TCS	From Vehicle Characteristics	1000000
VS	PMS	parking lot payment confirmation	1
VS	PMS	parking lot tag data	15
VS	PMS	advanced parking lot charges request	74
VS	RS	vehicle status details	4
VS	RS	ahs route data	2401
VS	RS	ahs vehicle condition	128
VS	TCS	toll tag data	15
VS	TCS	toll payment confirmation	1

### G.6 Some Problems with Beacon Systems

One of the serious drawbacks of wireless communication using beacons is transmission delays which occur while a vehicle is located in the dead zone between beacons. This is, of course, most significant for vehicles which are traveling slowly or are stationary for some period of time as illustrated in Figure G.6-1.



**Figure G.6-1 Transmission Delay as a Function of Vehicle Velocity**

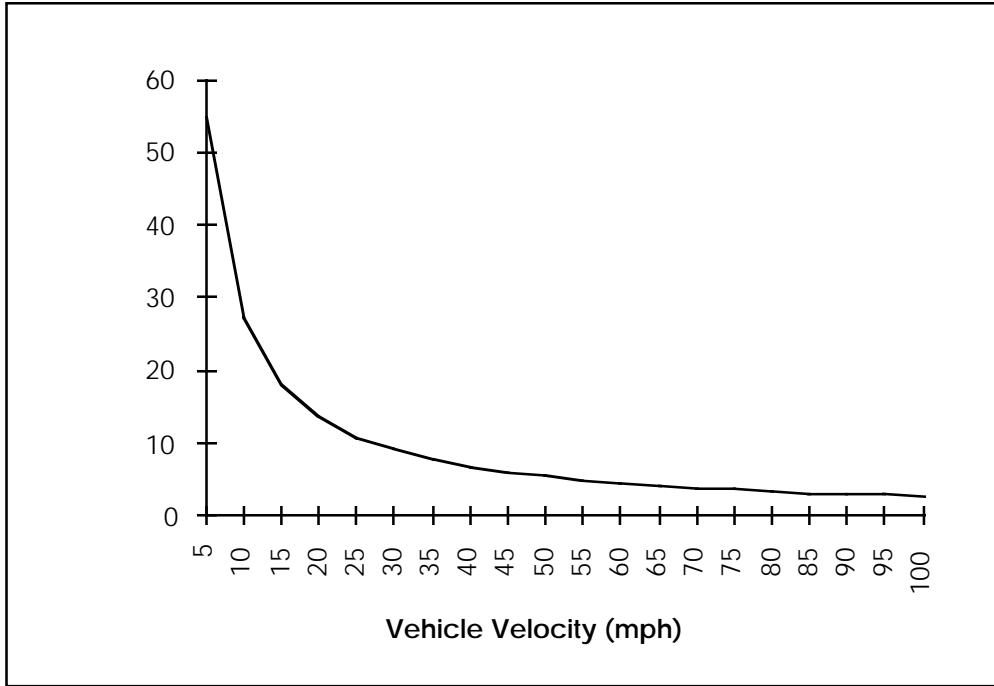
For example, a vehicle traveling 10 mph requires 93 seconds to traverse the 1360 foot dead zone between beacons. This should be compared with the following list of requirements for round-trip transmission time:

Driver information	5 seconds
En route transit advisory	5 seconds
Route guidance	5 seconds
Incident management	1 second
Traffic control	5 seconds
Commercial vehicle pre clearance	5 seconds
Automated roadside safety inspection	5 seconds
Commercial vehicle administrative processing	5 seconds
On-board safety monitoring	5 seconds
Commercial fleet management	15 seconds
Public transportation management	5 seconds
Personalized public transit	5 seconds
Emergency notification and personal security	1 second
Public travel security	1 second
Emergency vehicle management	1 second

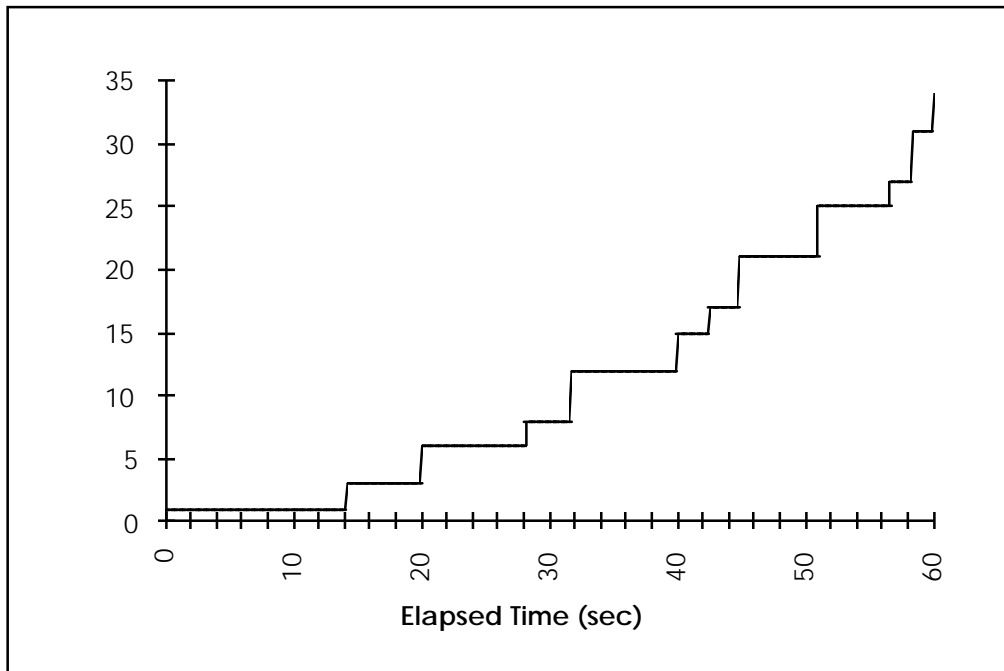
It is clear that a beacon system cannot meet transmission time requirements for many wide area ITS services under normal traffic conditions.

Another problem that surfaces with a wide area deployment of a beacon system is the complexity required to carry out two-way communications between the fixed center (ISP or TMC) and vehicles which move from one beacon to another during the exchange. The time a moving vehicle will remain in the coverage area of a beacon is plotted in Figure G.6-2.

For example, a vehicle traveling at 60 mph will traverse beacon coverage (400 feet) in 4.6 seconds. For many traffic types a query from the vehicle will elicit a response from either the TMC or a third-party provider. In many cases, the response will not be available until after the vehicle has left the coverage range of the beacon. Therefore, the TMC must direct its response to multiple neighboring beacons. Figure G.6-3 shows the number of beacons at which vehicles traveling at 60 mph might be located as a function of elapsed time assuming vehicle direction is known to the service provider within  $\pm 90$  degrees. Compensating for this location uncertainty will increase processing at the TMC or service provider and message storage at the beacons. In order to minimize wireless traffic, the beacon-to-vehicle communication protocol should restrict transmission of such responses to the first reader which establishes contact with the vehicle and transmits the response.



**Figure G.6-2 Time a Vehicle will Remain in the Coverage Area of a Beacon**



**Figure G.6-3 Location Uncertainty (number of beacons at which vehicles traveling at 60 mph might be located at) as a Function of Elapsed Time**

## **G.7 Summary**

An evaluation of beacon systems in the context of providing wide area ITS communication services has led to the following conclusions:

- A widely deployed beacon system would be technically capable of accommodating projected ITS wireless communications traffic within its footprint. Such a beacon system would however be inadequate and inappropriate for all time-sensitive wide area services due to holes in coverage.
- A beacon system is appropriate only for specific short-range services, requiring only a limited deployment. This avoids issues of delay, complexity and above all cost, which arise in connection with a widely deployed system. Examples of short-range services for which beacons are suitable include toll collection, truck clearance at borders, and roadside inspection (see Chapter 3 for the full details).

## APPENDIX H WIRELESS AND WIRELINE PROTOCOLS

### H.1 Wireless Protocols

#### H.1.1 CDPD

The wireless protocols for the CDPD test case are described concisely as follows:

1. Media access protocol:
  - DSMA/CD in the reverse link
  - TDM broadcast in the forward link
2. Link access protocol: MDLP
3. Error control/correction protocol: RS-coding plus TCP/IP control
4. Transport protocol: TCP
5. Networking protocols: IP
6. Routing algorithm/tables: IP
7. Packet processing algorithm: SNDCP

#### H.1.2 CDPD Protocols as Implemented in MOSS

The data delivery air-interface platform which is implemented on MOSS, follows the Cellular Digital Packet Data (CDPD) reverse and forward links protocols. The following is a short description of the CDPD part in MOSS, which draws closely from the CDPD system specification<sup>1</sup>.

In the forward link, MOSS implements a constantly transmitting Mobile Data Base Station (MDBS). By default, for a given base station and a given sector, MOSS randomly selects a single channel for CDPD use, out of the set of frequencies allocated to that sector under a given, most likely 3-sectored, frequency plan<sup>1</sup>.

---

<sup>1</sup> The default frequency plan used in MOSS, which meets the Advanced Mobile Phone System (AMPS) specifications, is given in *Mobile Telecommunications Systems*, W.C.Y. Lee, McGraw-Hill 1989.

MOSS' CDPD forward link transmission information includes periodically two signals that inform the mobile users on the reverse CDPD channel status: a "Busy/Idle" flag and a "Decode Status" flag. The content of these signals is constantly updated and is made available to the user community every seven CDPD "minislots" (a minislot last 3.1msec approximately), i.e., every RS-Block, the "quantum" of information in the reverse link. Note that no other information (more specifically no ITS information) is transmitted to the users in the forward link.

The performance of CDPD equipped cellular infrastructure for a mix of voice and data users hinges on the combined performance of the Physical layer and the Medium Access Control (MAC) layer on top of it. The task of the Physical layer design is to control the interference induced by co-channel voice users in other cells through the use of power control and error correcting codes (ECC), in this case a Reed-Solomon (RS) (63,47) code. The MAC protocol, on the other hand, resolves contention on the common reverse channel due to the competition with the other data users within the same cell.

In the reverse link, MOSS implements the random-access protocol as described in the *CDPD System Specification*. At the Physical Layer, the implementation uses independently computed results regarding the decoding performance of a CDPD receiver that meets the specifications. The CDPD receiver uses a two-branch diversity scheme called Decision-Directed Phase Estimation<sup>2</sup>. The receiver makes maximum use of knowledge of the waveform structure, and of all the information made available by the system (e.g., the sync and continuity indications on the reverse link, and sync words and flags on the forward link).

At the MAC layer, MOSS follows all the details of CDPD reverse channel random-access protocol, which conforms to a non-persistent Digital Sense Multiple Access with Collision Detection (DSMA/CD) protocol. Parts of the Mobile Data Link Protocol (MDLP) which relate to the CDPD re-transmission policy are implemented as well.

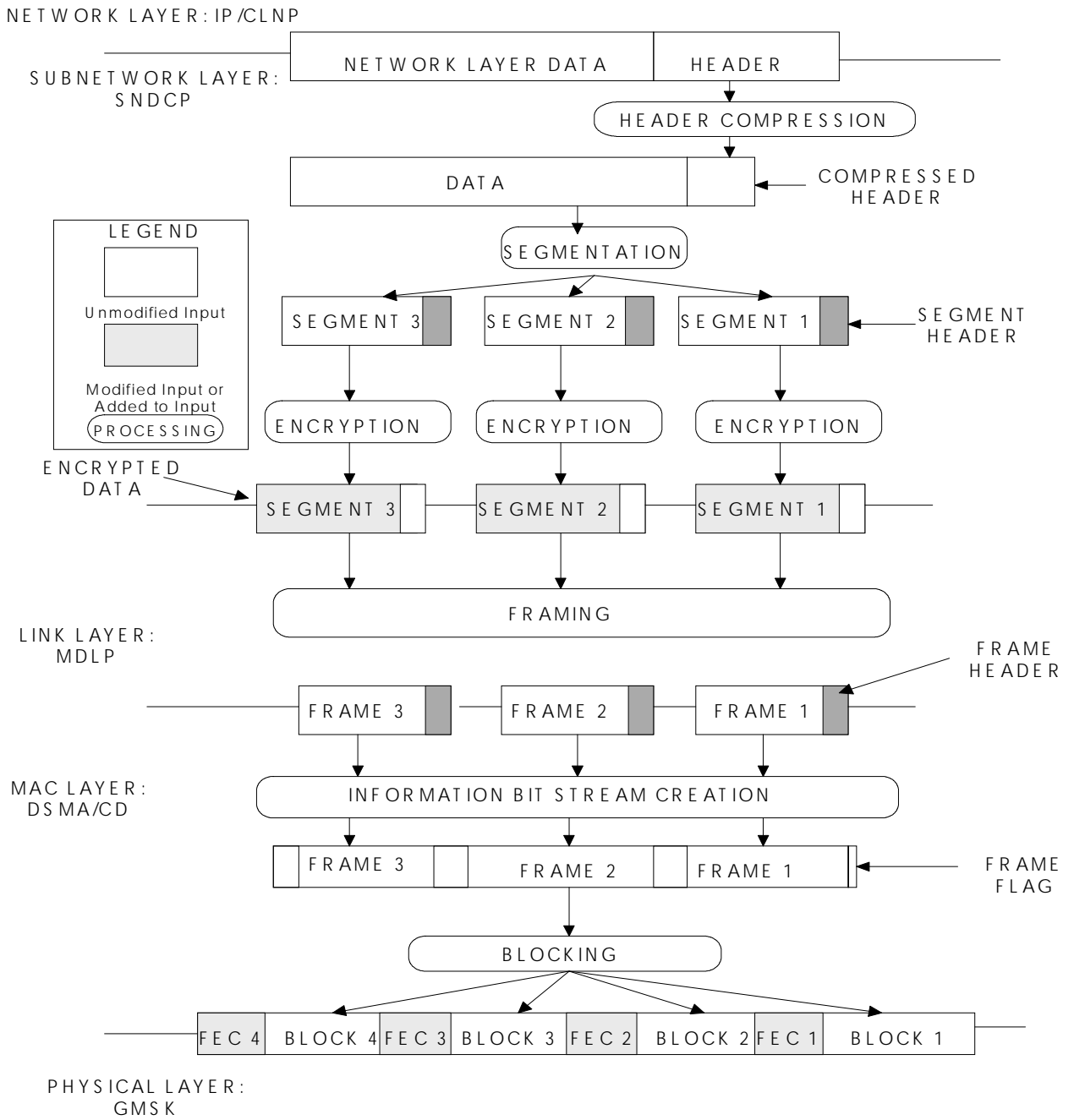
The CDPD specification (see Figure H.1-1 and H.1-2) establishes the Reed-Solomon (RS)-block as the quantum of information transmitted in the channel. Thus, the transaction lengths determined elsewhere in this document have to be converted to the corresponding number of blocks, taking into account the overhead introduced by TCP/IP.<sup>3</sup> In its present form, TCP/IP adds 40 bytes (320 bits) of addressing and control overhead to the first packet of each transaction. If more than one packet (are required, significant header compression gain (from 40 to 3 bytes on average<sup>4</sup>) could be achieved. Industry consensus at this time is that four RS-blocks is the optimum length of a packet. In the ITS case, all the transactions analyzed so far require only one packet in each direction, so no gain can be achieved.

---

<sup>2</sup> Described in *Digital Communications*, J.G. Proakis, McGraw-Hill, 1983.

<sup>3</sup> A recent reference on this subject is *TCP/IP Illustrated- Volume I: The Protocols*, W.R. Stevens, Addison-Wesley, 1994.

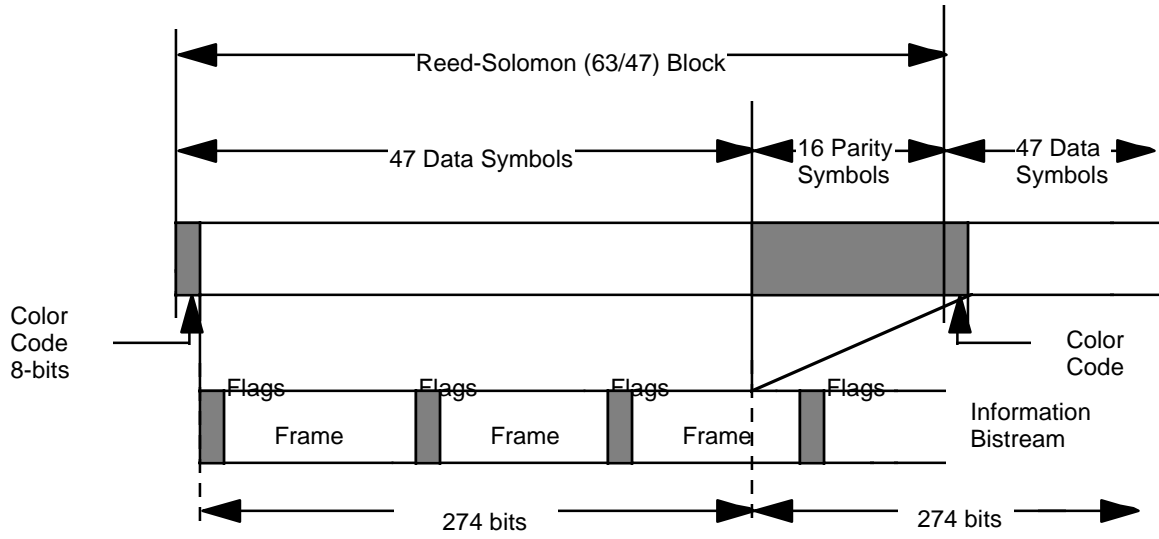
<sup>4</sup> The definitive reference for header compression is "Compressing TCP/IP Headers for Low-Speed Serial Links", V. Jacobson, Network Working Group Request for Comments 1144, February 1990.



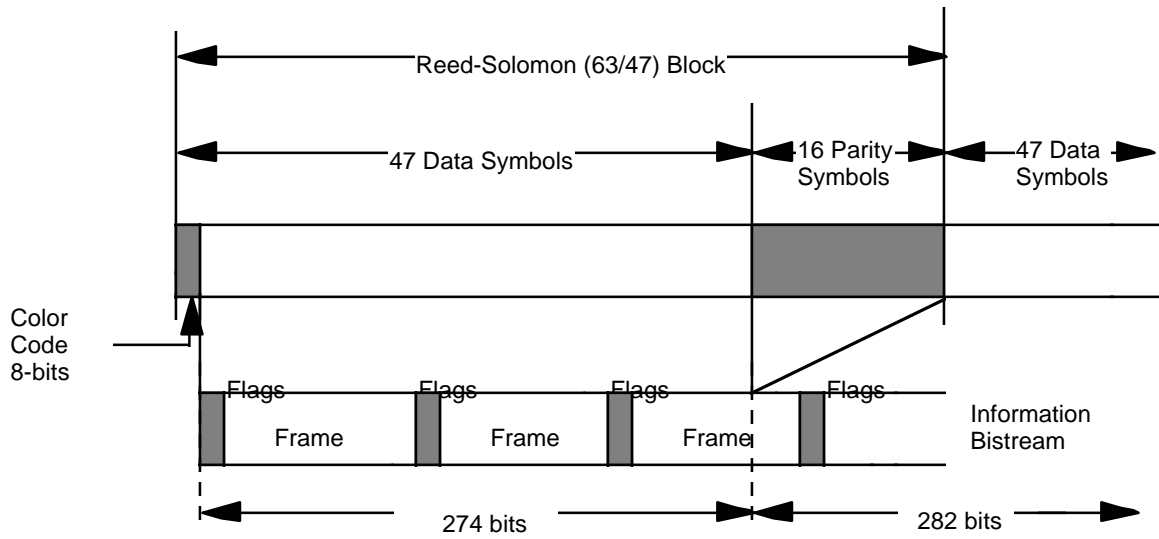
**Figure H.1-1 Packet Segmentation in CDPD  
(from CDPD System Spec-Release 1.0)**



## Forward Channel Framing and Block Structure



## Reverse Channel Framing and Block Structure



**Figure H.1-2 Framing and Block Structure for CDPD  
(from CDPD System Spec-Release 1.0)**

### **H.1.3 GPRS**

As soon as the information becomes available (i.e., as soon as the standard work at ETSI moves to a no-proprietary level), a brief, comparative description of the proposed protocol will be included.

## **H.2 Wireline Protocols**

Whenever appropriate, the protocols in the supporting wireline component will be matched with those of the wireless segment. More specifically, TCP/IP will be used to direct the information coming from/destined to the wireless portion. For the interconnection of the fixed network entities (e.g., TMCs, TIPs, ERCs, sensors, signals, CMSs), a host of protocols, with a point-to-point emphasis, are available. A few protocols have been considered for the Data Collection and Control network, namely Ethernet-like, FDDI, and ATM/SONET. They are described below.

### **H.2.1 Ethernet**

Ethernet is a bus-based local area network (LAN) technology commonly used today. Its operation is managed by a media access protocol (MAC) based on IEEE 802.3 standard. The role of this MAC protocol is to provide efficient and fair sharing of the communication bus connecting the stations in the LAN. The Ethernet MAC accepts data packets from a higher layer protocol and attempts to transmit them at appropriate times to other stations on the bus. However, because the higher layer protocols can forward data at any time and the bus is a broadcast medium, it is possible that several stations will simultaneously attempt to transmit resulting in packet collision. To resolve this problem, Ethernet's MAC protocol uses the CSMA/CD (Carrier Sensing Multiple Access with Collision Detection) scheme. This together with the "Truncated Binary Exponential Backoff" re-transmission mechanism promote Ethernet as one of the most powerful LAN protocols.

However, Ethernet has the following limitations when using fiber-based transmission for metropolitan-area communication between hubs and TMC in Urbansville:

- Ethernet is a coaxial-cable-based protocol. Therefore, electrical/optical (E/O) conversion is required as the interface between the optical signals transmitted and the electrical signals for processing.
- Ethernet is a LAN-based technology. For MAN application, such as our ITS architecture, the relatively large propagation delay will significantly degrade the system performance.
- Ethernet offers a typical data rate of 10 Mbits/sec. However, given that in our candidate implementation there are 6 Type-A and 3 Type-C hubs in Urbansville, each with 13 and 40 CCTV cameras, respectively, with each CCTV camera transmitting continuously at 64 kbits/sec, the total data rate required will be 12.672 Mbits/sec which exceeds Ethernet's nominal data rate. Therefore, Ethernet is not adequate to support this video traffic. A separate network for CCTV camera traffic would then be required.
- Ethernet cannot gracefully migrate to fully optical protocols such as ATM/SONET.

## **H.2.2 FDDI**

Fiber Distributed Data Interface (FDDI) is a fiber-based medium access protocol for metropolitan area networks (MANs). The nominal channel transmission rate is 100 Mbps. Although a logical ring network topology is required, this protocol can support both physical star and ring topologies as in our ITS system architecture candidate implementations.

There are two types of traffic at each hub, namely, the constant-bit-rate traffic from the CCTV cameras and the variable-bit-rate traffic from various traffic controllers/sensors. In order to support both types of traffic, we use an enhanced version of FDDI called FDDI-II. In FDDI-II, the whole bandwidth (100 Mbps) is divided into 16 wideband channels (WBC) of 6.144 Mbps each. Each WBC can operate either in isochronous (circuit-switched) mode or asynchronous (packet-switched) mode. In our case, we assign an integral number of WBCs to the constant-bit-rate CCTV traffic and then use the rest of the bandwidth for asynchronous transmission.

## **H.2.3 ATM**

Fiber Distributed Data Interface (FDDI) is a fiber-based medium access protocol for metropolitan area networks (MANs). The nominal channel transmission rate is 100 Mbps. Although a logical ring network topology is required, this protocol can support both physical star and ring topologies as in our ITS system architecture candidate implementations.

There are two types of traffic at each hub, namely, the constant-bit-rate traffic from the CCTV cameras and the variable-bit-rate traffic from various traffic controllers/sensors. In order to support both types of traffic, we use an enhanced version of FDDI called FDDI-II. In FDDI-II, the whole bandwidth (100 Mbps) is divided into 16 wideband channels (WBC) of 6.144 Mbps each. Each WBC can operate either in isochronous (circuit-switched) mode or asynchronous (packet-switched) mode. In our case, we assign an integral number of WBCs to the constant-bit-rate CCTV traffic and then use the rest of the bandwidth for asynchronous transmission.

## APPENDIX I SIMULATION TOOLS

### I.1 Introduction

The data volume analysis was completed using a database model. A separate database form was defined to model each of the groups of user services studied. A total of seven groups of services were studied: Traveler Information, Freight and Fleet Management - Local, Freight and Fleet Management - Long Haul, Private Vehicle Information, Public Transportation Management, Emergency Management, and Probes. The other ITS service groups (Traffic Management, Vehicle Monitoring and Control, and Electronic Payment) were not studied here explicitly, but their relevant wireless data flows (e.g., vehicle probes) were included within other services studied. Traveler Information is defined as information for a traveler other than a driver. Freight and Fleet Management - Local includes all commercial vehicle services operating only within the metropolitan area. Driver information is reserved for non-commercial driver services. The Public Transportation and Emergency Management functions serve those two specific areas.

As mentioned in the *Architecture Evaluation Plan* document under simulation strategy, the ITS communication system simulation will be configured into two modules: wireless and wireline/backbone. Although the wireless segment typically limits performance, the joint performance is required for complete characterization and optimization of the communication layer of the ITS system architecture. GTE Laboratories' proprietary tools MOSS and GRANET will be used to model the wireless candidate technology implementations, and the commercial package OPNET will be used to simulate the wireline/backbone alternatives.

The wireless communication module simulates the communication between the vehicles and the serving base stations (BSs) through the air interface, covering all radio aspects, namely fading channel, frequency allocation, modulation scheme, transmitted powers, antenna patterns, and multi-access protocols. This, obviously, is only a segment of the overall connection between the vehicle and the fixed transportation entities such as the traffic management centers (TMCs), traffic information service providers (TIPs), or fleet management centers (FMCs). The wireless module would also evaluate the communication between the TMC and roadway sensors/actuators if these connections are wireless in some physical architecture renditions.

The wireline module simulates communication between the BSs and the mobile switching centers (MSCs — MD-ISs in the CDPD nomenclature), and provides as well the connectivity to and among fixed transportation entities (e.g., TMCs, TIPs, FMCs, regulatory agencies, and kiosks). The wireline network also provides connectivity between a TIP and a personal computer

or cable TV user at home. Wireline is also likely to provide the connection between the TMCs and roadway sensors or traffic control signals. For the wide variety of fixed links and nodes identified herein the wireline simulation models link performance, processing at the switching nodes, and network routing protocols.

End-to-end (wireless and wireline) system performance will be obtained by feeding into the backbone simulation results derived from the wireless simulation. Dividing the communication simulation into the two separate modules has the following advantages:

- *Increases the programming and technical efficiency* — The wireless communication module uses cell-based (mobile) radio as the communication medium, while the "wireline" communication module uses either copper, optical fiber or fixed point-to-point microwave radio links. These two drastically different types of links (for fixed and mobile/portable users) have very different attributes and behaviors requiring distinct simulation capabilities and functions. In addition, the two modules, wireless and wireline, correspond to different mix of ITS user service traffic, with different traffic volumes, requirements, coverage areas, and with transport protocols that could well be very different. Partitioning the simulation into these two modules is therefore logical, and leads to enhanced utilization of specialized technical skills and programming efficiency.
- *Matches the strength of the simulation packages used* — The distinct transmission characteristics, communication schemes, and networking protocols require specific, highly developed simulation programs. A particular package (commercial or otherwise) typically does not provide an adequate simulation environment for both the wireless and the wireline communications. Partitioning the program into two modules allows us to take advantages of the strengths of the individual simulation packages.

It may be thought that the wireless and wireline communication modules should interact in real-time to simulate the end-to-end message transmission, for example between the vehicles and fixed entities like the TMCs, TIPs and FMCs. The wireless communication module would simulate how the packets are transmitted from a vehicle to a base station, and then the wireline communication module would take over the packets and simulates how a given packet is transmitted from the base station to the eventual fixed transportation entity. In the forward link, the fixed entity would, for example, answer the requesting vehicle or demand an update from it via the associated base station.

A close examination, however, reveals the following problems with a real time interface:

- *Incompatibility* — In general, integration of multiple commercial packages into a single interactive simulation requires heavy code translation and even code development. The increased overhead would offset any benefits resulting from the use of an integrated package.
- *Communication Overhead* — Large amounts of data would need to be transferred back and forth among the packages, significantly slowing the speed of the overall simulation.

Hence, in Phase 1, we consider off-line rather than interactive simulation with the following assumptions:

- The interaction between the wireless and the wireline communication modules occurs only as the data packet arrives at the base station and is delivered to the wireline communication module, or from the wireline communication module delivers a packet to the base station.
- The data packets suffer in the wireline portion of the communication system delays which are independent of those in the wireless portion, i.e., the delay distributions in the two segments are independent of each other.

The off-line interaction between the wireless and the wireline communication modules, i.e., between MOSS and OPNET, is as follows:

- The reverse wireless link simulation generates the input packet statistics for the wireline communication module. (Note : Voice is a factor in determining the wireless delay, but as soon as the data packets, ITS or non-ITS, reach the BS, it no longer affects the wireline behavior.)
- The wireline communication module, based on the data loading analysis and other market assessment derived inputs, generates the output packet statistics for the forward link simulation.

The packet statistics include the traffic matrix, the percentage of various traffic classes, the distribution of packet length, and the distribution of the packet inter arrival times.

The wireless communication module can be thought of as consisting of two wireless communication "sub-modules", one for each link: the up-link or reverse (i.e., from the vehicle to the base station) module, and the down-link or forward (i.e., from the base station to the vehicle) module. This division is convenient since different protocols are typically used on these two links. On the reverse link, many vehicles will share the same communication channel, and hence multi-access with collision-resolution protocols are used. In the forward link, on the other hand, the base station broadcasts messages to the vehicles, and thus a point-to-point protocol may be used.

The wireline communication module will simulate the data packet stream from the wireless communication by generating a packet arriving sequence with the statistics obtained from the reverse wireless module. On the other hand, the forward wireless communication module should simulate the data packet stream from the wireline communication by generating a packet arriving sequence.

## **I.2 Wireless Communications (Cellular/PCS)**

The primary wireless communication simulation tools used are MOSS and GRANET, both GTE Laboratories proprietary software packages. The selected wireline simulation tool was OPNET, which was also used in conjunction with MOSS+GRANET for end-to-end performance analysis.

MOSS simulates the performance of mobile and wireless communication systems providing both voice and data services. It computes voice and data link and system aggregate performance figures. GRANET is a radio planning tool for Cellular and Personal Communication Systems which models the mobile propagation environment, the allocation of frequency channels, and the management of all the relevant detailed infrastructure and scenario information.

MOSS and GRANET have been developed based on years of experience with analysis, design and modeling of practical, deployed or soon to be deployed, state-of-the-art wireless communication systems. GRANET, for example, has been extensively used by GTE Mobilnet in the U.S. and abroad (Germany, Israel, Korea, Japan) for radio planning, and because of its capability to be tuned by field measurements, has performed consistently very well as a prediction/analysis tool in various GTE cellular service areas. MOSS, on the other hand, contains unique capabilities that combine in-depth analysis of wireless data packet systems (ideal for ITS) with the realism derived from validation with the measured behavior of operational cellular systems.

OPNET, the wireline simulation tool, on the other hand, is a widely used commercial product. It is very versatile and very powerful; an excellent match to the analysis required of the wireline network — with its myriad possibilities of mixing and matching technologies to meet the needs of disparate scenarios and jurisdictions. OPNET will be used to simulate the CDPD protocol stack beyond the radio link. Loral's CDPD protocol simulation will be integrated with GTEL's CDPD channel characterization to provide end-to-end CDPD delay, a much missed information in Phase I.

The combination of MOSS, supported by GRANET, with OPNET offers the Joint Team the ability to analyze, predict, and tradeoff the performance of the communication architecture, including both the wireless and wireline segments, and their interfaces.

### **I.2.1 Graphical RADio Network Engineering Tool (GRANET)**

GRANET is a radio planning tool for Cellular and PCS developed by the Mobile Systems Department of GTE Laboratories. This planning tool consists of a collection of software modules for the modeling of the mobile propagation environment, the allocation of frequency channels, and the management of all the relevant input/output information, which may include geographical data, antenna patterns, FCC forms, demographics, traffic, overlay maps, etc. The complete package may be used to engineer and optimize analog and/or digital wireless communication systems.

GRANET, which is graphics-based and highly interactive, is designed to run on UNIX graphics workstations with an X-Windows/Motif user interface. The radio propagation model that forms the core of this planning tool was originally developed to provide accurate AMPS and DCS-1800 radio coverage predictions. This model is based on extensive experimentation, and if necessary, can be easily tuned to specific areas. The AMPS frequency planning module is based on collaborative research carried out with Professor J. McEliece of the California Institute of Technology beginning in 1989. In addition, GRANET incorporates basic CDMA planning features based on radio engineering technology currently under development at GTE Laboratories.

GRANET has the capability to calculate and display:

- Coverage map – The maximum field strength among all cells serving the area.
- Best server map – This is a graphical display of the area served by each cell, i.e., the area for which the field strength contributed by a cell exceeds both a minimum service threshold and the field from every other cell.
- Interference diagram – The tool displays the ratio of carrier (best-server field strength) to interference (the total field strength contributed by all other cells using the same frequency group).
- Frequency planning – State-of-the-art algorithms have been developed for automatically finding optimum frequency allocation. These algorithms resulted from a research collaboration between GTE Laboratories and the California Institute of Technology. Some of the frequency planning display techniques were developed by GTE Mobilnet.
- CDMA planning – The tool can display maps of soft/softer hand-off regions as well as forward/reverse link availability.
- Comparisons with experiments – This feature is useful for tuning parameters of the PCS model using experimental data.

- Geographical information – Any of the above results may be overlaid on a variety of digital maps from the geographical database included with the tool. This type of information is provided for all of the US.
- Carey contours, necessary for FCC filings.

The planning tool is able to handle an arbitrary number of sites, configured as omni or sectored, arbitrary antenna patterns (horizontal and vertical), as well as arbitrary antenna down tilt. A powerful feature of GRANET is its ability to carry out traffic analysis using population databases and marketing inputs.

### **I.2.2 MOBILE SYSTEMS SIMULATOR (MOSS)**

The MOBILE SYSTEM SIMULATOR (MOSS) is a proprietary software package that has been developed at GTE Laboratories for simulating the performance of mobile and wireless communication systems providing voice and data services. Development of MOSS began in January 1991, with the following major objectives:

1. To simulate the behavior of cellular mobile radio systems on a macroscopic level;
2. To determine overall system performance given knowledge of the performance of its elements; and
3. To be able to easily study the performance impact of varying system parameters and deployment methods.

MOSS' objectives have been met in the form of a stand-alone modular C program which can be run on any UNIX workstation. MOSS models both the forward (base station to mobile terminal) and the reverse (mobile to base) links in a wireless communication system, and includes the effects of teletraffic statistics, large scale propagation effects such as log-normal shadowing and power loss laws, channel assignment algorithms, configuration of network elements such as radio ports and antenna sites, antenna gain patterns, and other details of the layout and configuration.

The core of MOSS is an event-list-driven discrete-event simulator designed specifically for simulating the behavior of mobile systems. The core module processes all events in the system, such as arrival and completion of service requests (calls and protocol data units), power control initiations, and vehicle motion. The software also includes data structures that define the system geometry, track and compile statistics for individual connections and traffic at individual base sites and for the system as a whole. These data structures include data on features such as: antenna gain patterns for each radio port, radio port placement and antenna sectorization, channels available at each sector, transmit power at each sector, and propagation characteristics in the system. Statistics on various aspects of system performance are collected and reported. Separate statistics are kept for forward- and reverse-link performance on each occurrence of service.

In the cellular voice mode, calls are modeled with Poisson arrival and exponential holding times, but arbitrary distributions for these quantities can be easily incorporated. In particular, the concept of a call has been generalized to apply to data packets, and statistics appropriate for arrivals and lengths of data packets in various applications can be used/computed.

Propagation loss is modeled using the Okumura-Hata equation  $A + B \log_{10} D$ , where  $D$  is the distance in km,  $A$  is the 1 km intercept, and  $B$  is usually taken to be 3.46, which is a typical value encountered in cellular systems in urban environments. Log-normal variability of the received signal strength is taken into account by adding a zero mean normal random variable to the



propagation loss, expressed in dB. Standard deviations of 6 dB and 8 dB are typically used. MOSS can model three levels of system interference: 1) co-channel only, 2) co-channel and adjacent, or 3) co-channel, adjacent and alternate.

Currently, MOSS incorporates simulation of AMPS analog cellular systems, IS-54 TDMA cellular systems, and CDPD packet data for overlay on voice cellular systems. Enhancement of MOSS to include facilities for simulating CDMA cellular systems is also under way. In addition, MOSS functions will be integrated with a GTEL-proprietary radio propagation analysis and prediction software tool, GRANET, which will be described below.

Specific features of MOSS include:

- Discrete event simulation of mobile/wireless systems.
- Determination of quality and performance statistics of mobile systems: voice quality, data quality, blocked calls, dropped calls or messages, average delay, etc.
- Simulation of analog and digital cellular voice systems and cellular packet data systems.
- Accommodates arbitrary cell/radio port geometry, arbitrary antenna gain patterns and transmit powers, and allows for arbitrary specification of traffic sources and distributions.
- Implements reverse link power control.
- Multi-channel CDPD capability: more than one CDPD data channel per sector.
- Enhanced mobility functionality
- Interface to the GRANET propagation prediction tool allowing for detailed radio signal strength maps for specific service areas to be used in place of the generic Okumura-Hata models currently used in MOSS.

Users are able to model their individual systems by selecting from various blocks of code to meet their own specifications. Performance is evaluated by examining the statistics generated, in particular C/I ratios and the number of calls blocked. Performance can be re-evaluated following selected changes to the system, such as using different antenna types, using different channel assignment techniques, modifying the frequency plan, etc. System evaluation is rapid – as an indication, modeling a 3 hour run at 10 Erlang of traffic, executing on an HP 9000/730 unloaded workstation, takes approximately 10 minutes. Raising the traffic level to 40 Erlang takes approximately 2.5 hours.

Development plans that will span 1995 and 1996 include addition of GSM and CDMA modeling capabilities to the existing AMPS, IS-54 TDMA, and CDPD packet data capabilities:

- Detailed link-level analysis and simulation of the performance of the GSM/DCS-1800 air interface – This effort will include modeling the effects of coding and interleaving in conjunction with a fully functional receiver employing maximum likelihood sequence estimation for optimal detection of the GMSK wave form in the presence of channel multipath. The model will also include the effects of antenna diversity and slow frequency hopping.
- CDMA packet data performance – We will make use of the CDMA modeling capability developed in previous years to explore various packet data schemes for use as an overlay on systems that providing voice services according to the IS-95 standard for CDMA cellular service.

### **I.2.3 Integrated GRANET+MOSS**

As stated above, a modicum of integration between the two packages has already been achieved. However, it is still GTEL's purpose, independent of the National ITS Architecture effort, to proceed with the objective of full integration. The idea is to automate the use of the extensive mobile radio system simulation capabilities of MOSS with realistic propagation information obtained via GRANET (based upon topographical, topological, and land use information available through GIS data bases) made even more accurate via field measurement feedback, and not use MOSS' default Okumura-Hata model.

During Phase I, GRANET was used to obtain very realistic scenario propagation data for Detroit based upon topographical, topological, and land use information available through GIS data bases. Feeding this information into MOSS resulted in a rather tedious task which is currently being automated.

In Phase II, two other regions are being considered, corresponding to the Thruville and Mountainville scenarios, namely the Philadelphia-Trenton corridor, and Lincoln County, Montana. At this time, only coverage information is available, based upon information lifted from the operating cellular companies' FCC filings. Additional analysis using MOSS will have to be postponed until more complete, better information on the cellular deployment in those two area is obtained.

### **I.3 OPTimized Network Engineering Tools (OPNET)**

Commercial simulation packages are usually designed for special types of problems, and their performance varies. The choice of OPTimized Network Engineering Tools (OPNET) as the simulation package for the wireline communication simulation stems from the following strengths of OPNET:

- A variety of library programs – OPNET addresses all the related levels of digital communication networks, including network architectures, node structures, protocols, data transmissions, and operational environments. A variety of library model programs, particularly those of wireline communication networks, are included in this package.
- The most recent version of OPNET includes a model for ATM, as well as an highly simplified model for cellular radio (in that it does not account for all the interference caused by voice and data in an actual cellular deployment, nor for the actual number of channels available for CDPD — in no way a match for the MOSS+GRANET combination).
- Open environment and compatibility with C – OPNET is a set of UNIX-based C programs, and hence it is compatible with C. In addition, OPNET has an open design environment in which user-developed C programs can be easily incorporated into an OPNET program.

OPNET is a dynamic, event-driven simulation package and as stated above particularly suited as a simulation tool for modeling protocols and evaluating the performance of large communication networks. Some of the features of OPNET are listed below:

- OPNET has a hierarchical, object-based structure – Programming is done hierarchically from the network, the node, and the process/link models. The module is object-based, which allow the extensive reuse of the same code in different simulations.
- OPNET allows for the graphical specification of models – The input of the network topology can be done using the graphical interface. The library models can be selected using the graphical interface. Some programs can be written from the state transition diagram using the graphical interface.
- OPNET has comprehensive data analysis tools – There are many complicated data analysis functions in this package and specific variables can be probed and selected as the performance measures. The results of data analysis can be displayed using a powerful, user friendly graphical display.

OPNET is very versatile and powerful package, indeed an excellent match to the analysis required of the wireline network with its myriad possibilities of mixing and matching technologies to meet the needs of disparate scenarios and jurisdictions. Simultaneously, its wireless capabilities are increasing, with new cellular and satellite models recently added.

#### **I.3.1 Wireline Communications**

All Government-provided scenarios will be analyzed, for the evaluatory designs identified in the Physical Architecture. The same wireline topology alternatives analyzed in Phase I, namely Ring, Star, and hybrid, will be considered again in Phase II, where appropriated (a backbone infrastructure is not likely to exist in the rural scenario), for all transportation mechanisms already studied, namely FDDI, and Ethernet, with the addition of ATM modeling.

### **I.3.2 Wireless + Wireline Simulation Integration**

As mentioned above, GTEL's MOSS deals primarily with the lower layers of the CDPD stack (Physical and MAC layers), taking into account in its entirety the actual cellular environment under consideration, providing realistic over-the-air delay characterization. The upper layers of the stack were not analyzed in detail since they were expected to add only a small fraction to the overall CDPD delay.

In Phase II, we have combined GTEL's precise characterization of the radio channel with Loral's protocol stack simulation capabilities. For that purpose, Loral's OPNET simulation of the CDPD stack will be enhanced by substituting GTEL's radio channel characterization for the lower layers of the stack. We expect thus to answer to the concerns expressed by the Technical Review Team (TRT) referring to the overall performance of the CDPD channel.

### **I.4 Validation of the Modeling Tools**

It is recognized that a primary problem in the development of any simulation is verification of the correctness of the simulation and the numerical results from the simulation. Whenever possible, the simulation results obtained using the models above will be compared with available field measurements. Otherwise, the following methods have been successfully used at GTE Laboratories to control the possibility of simulation error:

- Analytical Models – Where possible strong in-house analytical skills have been utilized to build analytical models. Typically, it is not possible to develop analytical models that capture as much detail as a good simulation, which is the reason for building the simulation. Nevertheless, analytical models provide data points for special cases and bounds for more general cases and have been used to check the operation of the simulations.
- Published Results – Results for certain designs and special cases are frequently published in the open literature. Such results have been used in the same way as internal modeling efforts to provide data points and bounds for verifying internally generated simulation results.

Industry and Professional Contacts – GTE Laboratories staff members have extensive contacts in the industry, through participation in industry standards activities and other industry meetings, working arrangements with cellular equipment manufacturers, and professional and academic relationships. Results from work in progress in other companies on performance evaluation have been and continues to be available through these channels when not available elsewhere. This input has frequently proven to be very useful in validating internal simulation results.

## **APPENDIX J CDPD FIELD TRIAL RESULTS**

### **J.1 Introduction**

This appendix presents a synopsis of the results of a technical trial where CDPD was used as the communication medium to transfer information between a fleet of vehicles and a fleet management dispatch center. The trial was performed during the first half of 1995 in GTE Mobilnet's San Francisco Bay Area Region. The trial involved GTE Mobilnet and GTE Laboratories in collaboration with Rockwell International who provided the software and hardware of their "FleetMaster" fleet management application. It also involved a commercial fleet customer (to remain confidential).

The trial activities included adapting the Rockwell FleetMaster hardware and application software (which was initially developed to operate over conventional SMR) to interface with CDPD modems and to operate smoothly over the CDPD network. (In the FleetMaster system, each vehicle carries a "NavCell" which contains a GPS receiver which determines vehicle location from GPS satellite transmissions. The CDPD network provides communication with the personal computer-based FleetMaster base station located in the Fleet operator's dispatch center.) The trial included a host of technical field tests and culminated in demonstrations of performance in customer fleet vehicles.

The remainder of this appendix will summarize the salient components of the trial and will focus on the CDPD application's end-to-end performance results demonstrated in the field. The exposition will essentially be limited by the need to protect proprietary and competition sensitive information pertaining to both the FleetMaster product and GTE's CDPD network infrastructure. Business related results are also not included.

## J.2 Trial Objectives

The first broad objective of the field trial was to investigate and assess the technical feasibility and viability of CDPD service for local commercial vehicle operations with a real customer. The second broad objective was to gather data on message traffic and billing in order to assess service structures and pricing for local truck dispatch operations.

The objectives of the trial translated into the following field testing tasks:

- Verify satisfactory operation of the FleetMaster application and its interface to the CDPD network.
- Test operation with different transport protocols (TCP and UDP).
- Verify satisfactory CDPD coverage throughout the area served by the commercial fleet customer.
- Verify mobile operation, particularly prompt recovery from any radio outages (e.g., due to tunnels or mountains), and smooth, rapid sector hand-offs.
- Perform side-by-side comparisons of multiple CDPD modems, particularly regarding speed and reliability of hand-offs.
- Test CDPD system loading limits.
- Obtain billing records of on-the-air operation to allow customer-specific cost prediction.
- Obtain extensive log files for detailed post-field-trial investigations.

## J.3 Trial Participants

A trial of a new infrastructure technology with a new, emerging customer application is a major effort that requires a significant amount of coordination, as well as an engineering and business team with specialized and synergistic capabilities. This is reflected in Table J.3-1.

**Table J.3-1 Participating Organizations and their Responsibilities**

<b>Participant</b>	<b>Responsibility</b>
GTE Labs	<ul style="list-style-type: none"> <li>• Trial Plan Preparation</li> <li>• Test Plan Development</li> <li>• Lab Integration, Setup and Testing</li> <li>• CDPD protocol analysis support</li> <li>• Field Testing (Bay Area)</li> <li>• CDPD Field Performance Evaluation</li> </ul>
GTE Mobilnet	<ul style="list-style-type: none"> <li>• CDPD Operation and Network Support</li> <li>• Lab and CDPD analysis support</li> <li>• Provisioning &amp; Billing System Support</li> <li>• Customer Satisfaction Assessment</li> </ul>
Rockwell	<ul style="list-style-type: none"> <li>• Dispatch Center Hardware/Software</li> <li>• CDPD Application Software</li> <li>• Mobil Unit Hardware/Software</li> <li>• System Installation, Integration &amp; Testing</li> <li>• Test Plan Development Support</li> <li>• Customer Satisfaction Assessment</li> </ul>
Customer	<ul style="list-style-type: none"> <li>• Performance Evaluation</li> <li>• Truck Fleet Test Platforms</li> <li>• Host for Control Center</li> </ul>

## J.4 FleetMaster System and Trial Configuration

The configuration and connectivity used in the trial is shown in Figure J.4-1. In the FleetMaster system, each vehicle carries a NavCell which contains the GPS receiver, processing, and a communication interface (RS-232). When configured for SMR operation, the NavCell contains a modem board which interfaces to the audio input of the SMR radio. When configured for CDPD operation, a CDPD modem (transceiver) is connected to the communication interface to provide connectivity, through the CDPD network, to the fleet operator's dispatch center as indicated in Figure J.4-1. CDPD modems (actually modem/radio transceivers) are provided by third party vendors. Modems from Cincinnati Microwave Inc. (CMI) and PCSI were used in the trial. More extensive testing was performed with CMI's DART-100 modem due to software development considerations in the FleetMaster system during the trial period.

The personal computer-based FleetMaster base station located in the dispatch center contains geographical data. This interface consists primarily of a map display window on which icons show the current locations of vehicles being tracked. In addition, there is a system message display window and other interactive interface tools that enable the system operator to control the display parameters, vehicle configuration, communication parameters, polling/reporting status, and other aspects of the system.

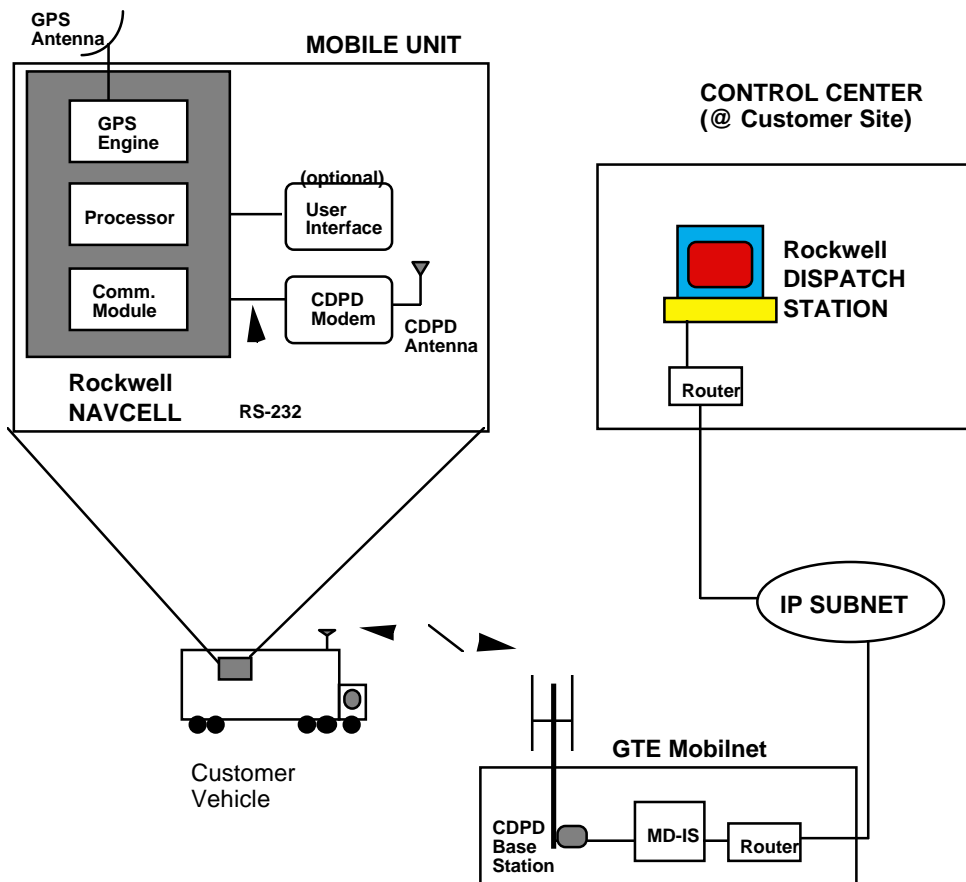


Figure J.4-1 CVO-CDPD Field Trial Configuration

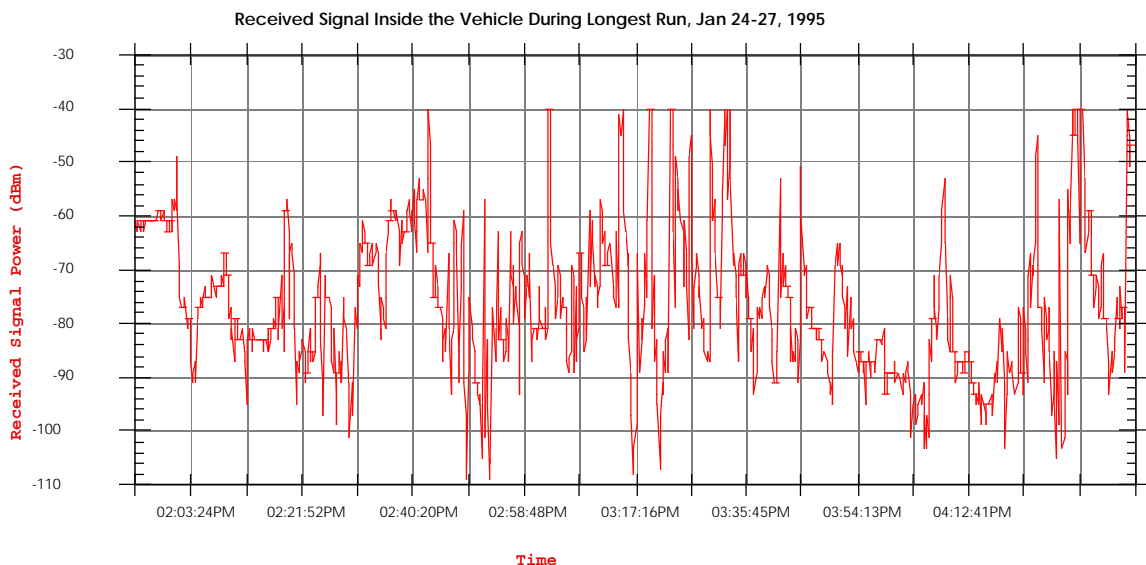
## J.5 Sample Field Results

### J.5.1 Signal Strength and Waiting Time Measurements

Runs were performed as early as January 24-27, 1995. In CDPD terminology, the Mobile End System (MES) consisted of the NavCell connected to the CDPD modem. The CDPD modem used was CMI's MC-DART 100 and the protocol used during those runs was TCP. The CDPD deployment at the time was in many but not all voice cells in the San Francisco Bay area. (Roughly half the cells for voice covering the entire cellular region, extending from Napa to Santa Barbara, were deployed). The deployed cells had one CDPD dedicated channel per sector. A rental vehicle was used to travel some extended routes in the Bay Area while a ThinkPad laptop computer equipped with an internal Ubiquity 1000 CDPD modem measured and recorded signal strength in the vehicle. Although the signals received by the MC-DART with an antenna external to the vehicle and the Ubiquity modem with an attached antenna are not instantaneously correlated, this setup provided very useful macroscopic information on the propagation conditions encountered in the field. This is particularly true in light of the incomplete CDPD deployment at the time.

To facilitate the analysis of the test results, complete logs were kept of the experiment. These included the logs of the TCP/IP software (from Distinct) residing at the dispatch center (also called the Fixed End System or FES in CDPD language), which kept track of all IP packets originating and destined to the FES, and the ThinkPad logs which included information on signal strength and selected channel in a given cell. Besides these logs, the FleetMaster application logs (also at the FES) registered all transactions, including all retries. The FleetMaster system was configured to poll the vehicle regularly. (As will be discussed later, during normal fleet operation vehicle reporting without polling is the more efficient approach used.)

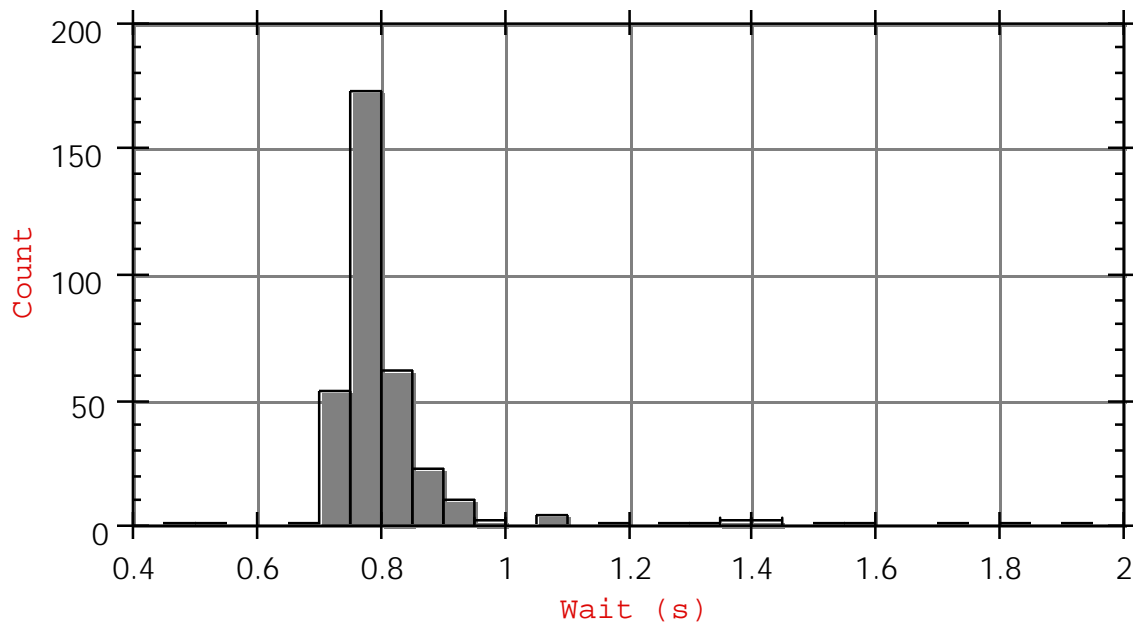
Figure J.5-1 shows the signal variation measured during the longest run around the Bay Area with the IBM ThinkPad with built-in Ubiquity 1000 CDPD modem programmed to log the received signal strength every 10 s. Besides the usual short fades encountered in the mobile environment, a few long "fades" were also experienced. Those were easily identified with some sheltered canyon situations, a long tunnel, and the lower deck of the Bay Bridge, where CDPD coverage had not yet extended.



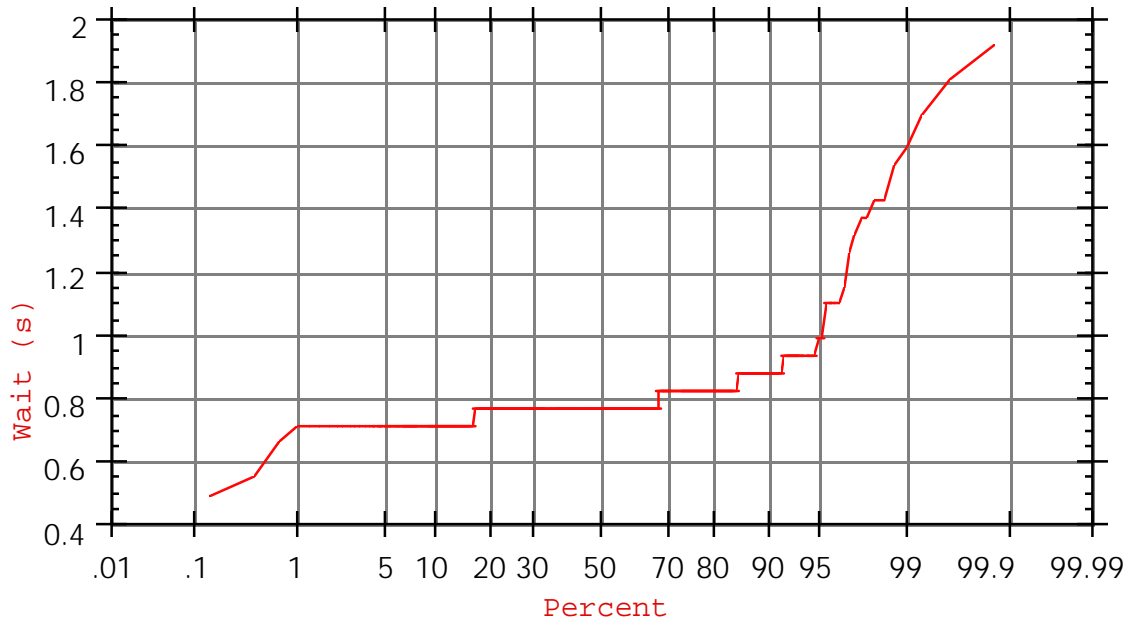


**Figure J.5-1 Received CDPD Signal Strength Inside a Vehicle During a Run in Jan. 1995**

The wait associated with the polling transactions, defined as the time between the polling query and the reception of the answer at the F-ES, measured from the Distinct log files, is shown in Figure J.5-2. (Instances where polling was not successful due to lack of coverage, as in a tunnel or sheltered canyon are not represented in the plot.) Tests were performed during different hours of the day, and many were performed during the afternoon/evening rush hours. Two way end-to-end delays stayed generally below 1 s, and showed no particular dependence on the time of the day. Figure J.5-2 and J.5-3 show the probability density function (pdf) and the cumulative distribution function (cdf) of the waiting time, respectively. The average wait for an answer from the NavCell was 0.812 s. In practice, this limits the polling rate with TCP to once every few seconds. (Typically in a commercial application a much less frequent update rate is used.)



**Figure J.5-2 PDF of the Polling Waiting Time**



**Figure J.5-3 CDF of the Polling Waiting Time**

### J.5.2 TCP versus UDP

The adaptation of FleetMaster to CDPD, involved the typical challenges of upgrading from a legacy communication technique to a modern, information age one. CDPD is a TCP/IP protocol suite-based system. TCP is responsible for maintaining reliable sessions between the mobile (MES) and the fixed dispatch center (i.e., the FES). In a traditional radio system, no such intelligence exists. Hence the application layer itself is responsible for maintaining the integrity of the end-to-end link. Correspondingly, the application, when requested (as an option) performs the acknowledgments. Although the difference between having the application and transport layers perform this maintenance task seems insignificant at first blush, it is anything but that when successful interfacing of the application software to the protocol stack is the task at hand. Significant application software adaptation is required to avoid anomalous operation when outages are encountered-- as they inevitably do in a dynamic wireless environment.

A fleet dispatch application is one wherein repeated transmissions from the vehicle take place over time as the vehicle progresses along its route. In many cases, an acknowledgment is not required if the transmission medium is sufficiently reliable and the dispatcher can tolerate the occasional loss of a position report.

Because of the original design of the FleetMaster application and the observed overall reliability of the CDPD medium it was decided in the middle of the trial to switch from TCP (guaranteed delivery) to UDP (not guaranteed). Since the application is capable of acknowledgment when requested to do so, extremely high reliability could still be maintained with UDP when desired.

In addition to the simplification in programming the application interfaces, a cost advantage is realized for the customer. UDP has a small billable header of 8 bytes. TCP on the other hand, has a header of 20 bytes; moreover, all routine transport layer acknowledgments are also billed per byte. Thus, the guaranteed delivery of TCP comes at a price, which can be avoided in the fleet dispatch application over CDPD. It should be noted that TCP header compression, which is

implemented automatically for transactions containing multiple packets, is not useful here, nor in most ITS mobile applications, because the transactions are typically short (few tens of bytes), and fit well within a single CDPD packet.

### **J.5.3 CDPD System Loading Limits**

During the March 27 - 30, 1995 period a simple but telling test of the CDPD system's loading limits was performed. Operating two NavCell/MC-DART mobile units within the same sector reporting at the intentionally exaggerated rate of once per second did not cause any appreciable network delays. (UDP was the protocol used at that point.) Adding other significant background users in the same sector started causing delays and intermittent operation of the application. The capacity demonstrated successfully, however, far exceeded the requirements of the application or network loading in the foreseeable future. It is equivalent to the simultaneous operation of 600 NavCell/CDPD-equipped vehicles in the same cell sector if we assume a more representative five minute reporting interval.

### **J.5.4 Application Inter-Arrival Times with UDP**

During tests conducted on March 29-30, 1995, position reports were transmitted from the mobiles either autonomously at approximately fixed intervals or in response to polls sent from the dispatch center at approximately fixed intervals. (The software timers in both ends of the application depended on previous events and did not follow precise repetition intervals.) If the vehicle were in a "hole" in coverage, or if the application were in the process of recovering from an outage, position reports would not be received at the expected intervals. Thus, by examining the intervals separating the arrivals of position reports at the dispatch center, insight was into both the coverage of the CDPD system and operation of the FleetMaster application when using UDP.

On March 29 a mobile unit was set to "broadcast" – that is, report to the dispatch station – at 15 second intervals without acknowledgments from the dispatch station. Figure J.5-4 indicates that the inter-arrival times were tightly clustered around a value slightly higher than the preset value. In addition, a number of position reports arrived at very small intervals. The FleetMaster log reveals that on a number of occasions a brief outage was followed by the arrival of several position reports in rapid succession. Only nine out of 312 intervals exceed one minute, indicating a success rate of 97%.

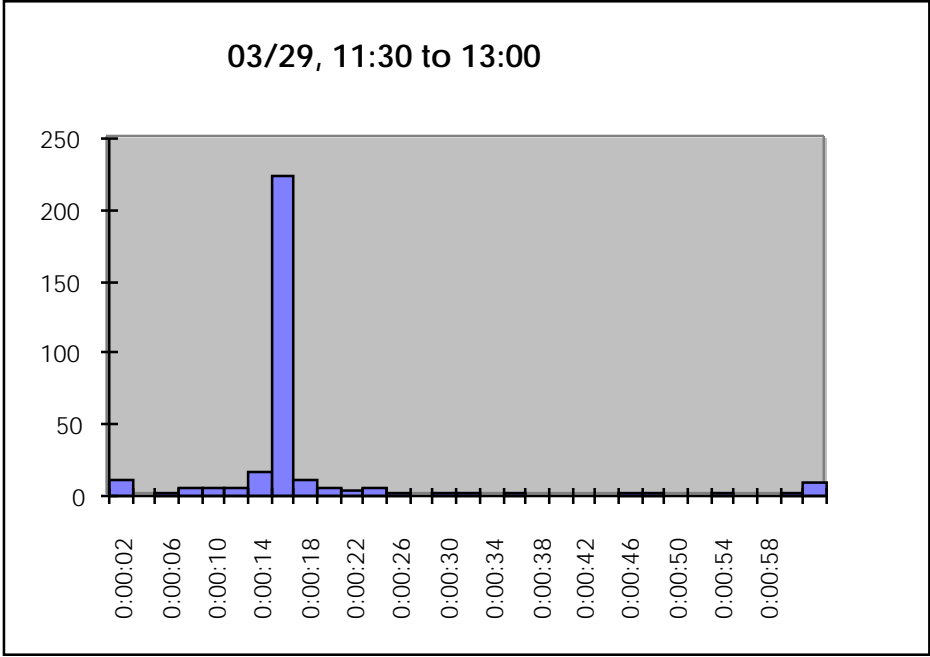


Figure J.5-4 Histogram of Inter-Arrival Times Between Position Reports in FleetMaster Log (reporting at roughly 15 s intervals without ACK)

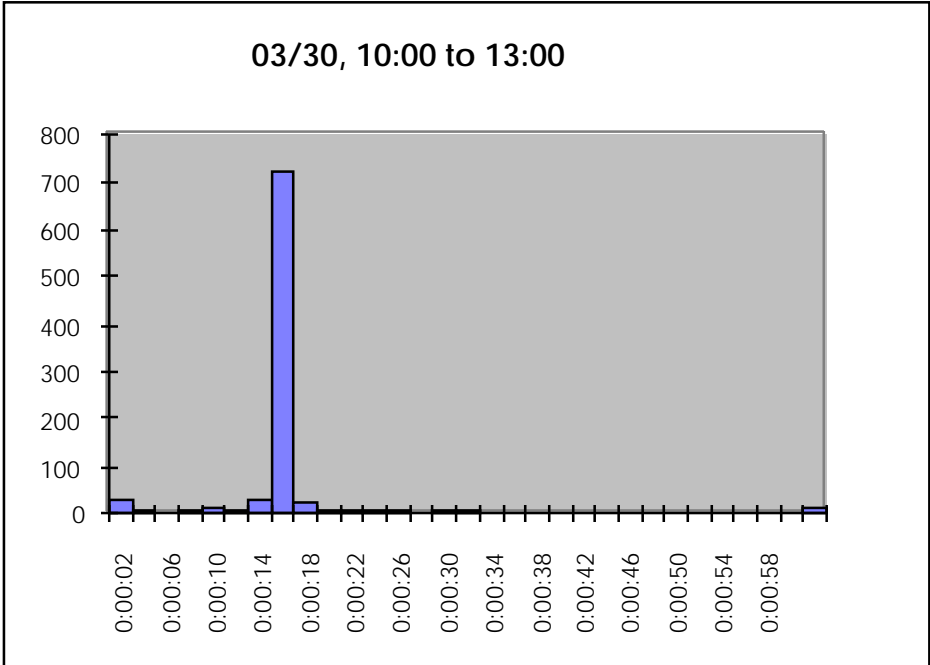
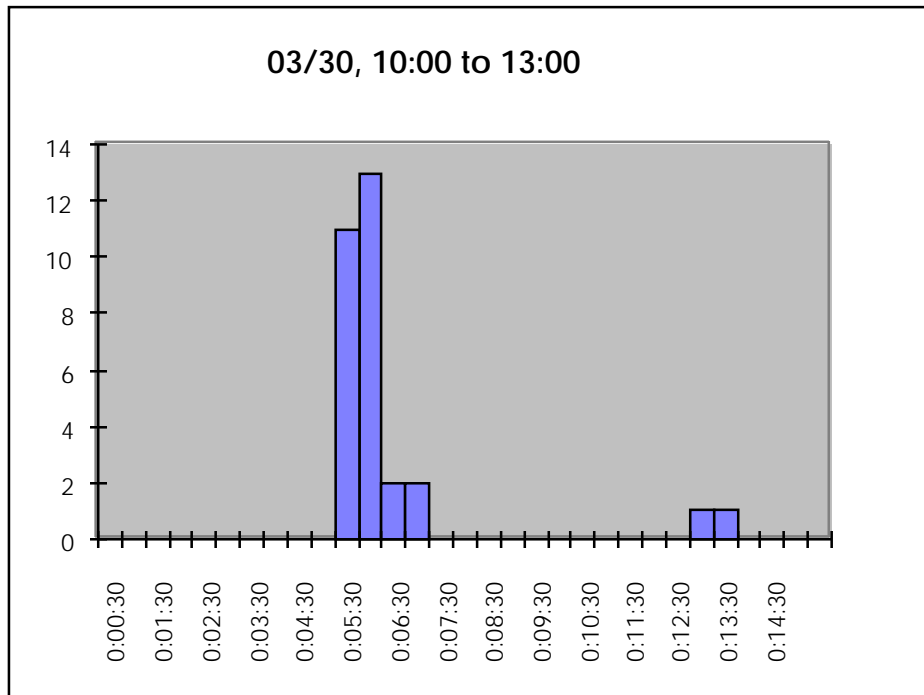


Figure J.5-5 Histogram of Inter-Arrival Times Between Position Reports in FleetMaster Log (reporting at roughly 15 s intervals without ACK)

On March 30 another mobile was set to “broadcast” position reports at 15 second intervals without acknowledgments from the dispatch station. Only twelve out of 861 intervals exceed one minute, indicating a success rate of 99%. This is depicted in the histogram of Figure J.5-5.

A second unit was set to “broadcast” position reports at 30 second intervals but with acknowledgments from the dispatch station. Only twenty out of 343 intervals exceed one minute, indicating a success rate of 94%.

Finally, a third unit on the same day was configured to resemble a more realistic operational environment over a very wide geographic area during a three hour run. The mobile was polled by the dispatch station at 5 minute intervals. If no response was received a second pole was sent automatically after 30 seconds. Figure J.5-6 indicates only two instances out of thirty where the interval between position reports differed significantly from the five minute value. This indicated a success rate of 93%.



**Figure J.5-6 Histogram of Inter-Arrival Times Between Position Reports in FleetMaster Log (Polled at roughly 5 minute intervals with re-poll at 30 seconds.)**

The primary conclusion to be drawn from this analysis of inter-arrival times is that coverage in the area served by the fleet customer was generally good, with success rates ranging from 93% to 99%. This includes the severe environment of downtown San Francisco. There are some localized areas where there are holes in CDPD coverage. These should not impact customer operations significantly, and would be eliminated as the CDPD deployment continues.

An additional conclusion that may be drawn from the inter-arrival time data is that operation of the application using the UDP protocol was smooth. In general it was observed that the application recovered quickly from any outages which occurred due to holes in coverage. Finally, network operation seemed to be completely transparent to the application in the sense that no

significant delays are incurred in handling the CDPD traffic. As mentioned earlier, there was no perceptible variation in the performance as a function of the time of day or the voice activity on the rest of the cellular network.

### J.6 Operation in Customer’s Vehicles and Billing System Validation Tests

A billing validation test was performed using the three customer vehicles equipped with NavCells . The vehicles conducted an approximately ten hour operational run in the Bay Area and the FleetMaster application logs were compared with information obtained from the billing system of GTE Mobilnet.

The NavCells of the three vehicles were configured by the FleetMaster dispatch computer to transmit at three different intervals (1) thirty seconds, (2) one minute, and (3) five minutes. The three vehicles had different routes. Vehicle #1 traveled from Oakland to San Francisco, spent most of the day traveling in San Francisco, and then returned to Oakland. Vehicle #2 spent most of the day traveling in the areas south of San Francisco, traveling from Oakland to San Francisco, to Burlingame, San Mateo, Redwood city, San Carlos, Belmont, Foster city, Hayward, San Leandro, and then back to Oakland. Vehicle # 3 traveled primarily in the East Bay, from Oakland to Concord, Walnut Creek, Lafayette, to San Francisco and then back to Oakland.

For the duration of this experiment, the Customer’s FleetMaster dispatch computer recorded the transactions from the three vehicles at the specific rates (for example, thirty second intervals). The recorded transactions included the following information: (1) time, (2) status, and (3) location.

The records of the FleetMaster transactions were inspected and the total number of bytes was calculated for each vehicle. The summary of the results is depicted in Table J.6-1, which also presents the reported transaction bytes from the Mobilnet billing system.

**Table J.6-1. Comparison of Application Log and Billing Records**

Vehicle ID	Interval Between Transactions	Total No. of Bytes* from Customer’s FleetMaster Log	Total No. of Billable Bytes from Mobilnet Billing System	Deviation Between the Billing Record and Customer FleetMaster Log
Vehicle #1	30 Sec.	82946	83376	0.5 %
Vehicle #2	1 Min.	44402	44294	0.2 %
Vehicle #3	5 Min.	6538	6550	0.18 %

\* Application (vehicle report) data payload plus the 8-byte UDP header per transaction (a few non-standard size transactions at power-ups are also accounted for)

## **J.7 Summary of Conclusions**

The trial demonstrated that the CDPD network is technically very well suited to the needs of fleet management systems. Specifically, it was found that:

- The CDPD system's loading limits well exceed the requirements of the application or network loading in the foreseeable future.
- End-to-end delay experienced in the CDPD network is on the order of a second and has a positive impact on operation of the application.
- Coverage in the area served by the commercial fleet customer was generally good, with transmission success rates ranging from 93% to 99%. This included the severe environment of downtown San Francisco. (Only a fraction of the base stations in the entire cellular territory of GTE Mobilnet were equipped with CDPD at the time; the service roll-out has since expanded.)
- Billing records accurately represented actual network traffic.
- CDPD modems from two manufacturers had different characteristics including different speed of hand-off between cells or channels.
- The UDP protocol is more suitable for operation with the FleetMaster application than TCP. In addition, UDP is more cost-efficient for the customer due to its lower packet overhead and the elimination of transport layer ACK's.
- A CDPD approach is a viable, cost-effective solution for fleet management operations.